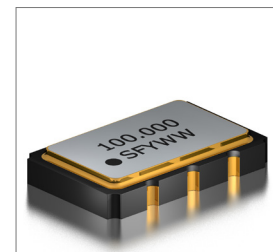

Features
• $\pm 20$ ppm (Frequency Stability) Available
• Ceramic Package
• LVDS
• Programmed VCXO
• Tape and Reel

Applications
• Micro Processors
• FPGA
• Storage Area/Networking
• Digital Video
• Portable Computers

**Part Numbering Guide**
**SQV 53 L 3 A 48 A 2 - 100.000M**

 SUNTSU QUICK  
TURN VCXO

5.0mm x 3.2mm

LVDS

**SUPPLY VOLTAGE**

 2 : 2.5V $\pm 5\%$ 

 3 : 3.3V $\pm 5\%$ 
**FREQUENCY STABILITY**

 A :  $\pm 50$ ppm

 B :  $\pm 30$ ppm

 C :  $\pm 25$ ppm

 D :  $\pm 20$ ppm

 \*E :  $\pm 15$ ppm

**OPERATING  
TEMPERATURE RANGE**

07 : 0°C - +70°C

16 : -10°C - +60°C

17 : -10°C - +70°C

27 : -20°C - +70°C

38 : -30°C - +85°C

48 : -40°C - +85°C

**FREQUENCY**  
MHz

**TRI-STATE  
(ENABLE/DISABLE)**  
BLANK : No Connect  
2 : Pin 2

**PULLABILITY**

 A :  $\pm 150$ ppm

 B :  $\pm 100$ ppm

 C :  $\pm 80$ ppm

 D :  $\pm 50$ ppm

Cage Code: 4GUT4

To customize your parameters contact a Suntsu representative.

\* For frequency stability option E contact a Suntsu representative.

Electrical Parameters	Units	Minimum	Typical	Maximum	Remarks
Frequency Range	MHz	8		1500	
Frequency Stability (Includes Initial Tolerance at 25°C, Frequency Stability over Op Temp, Output Load Change, Supply Voltage Change, and First Year Aging at 25°C.)	ppm	-20		+20	See part numbering guide for options.
Operating Temperature	°C	-40		+85	See part numbering guide for options.
Storage Temperature	°C	-55		+125	
Supply Voltage (V <sub>DD</sub> ) 2.5V Option	V		2.5	2.625	
Supply Voltage (V <sub>DD</sub> ) 3.3V Option	V	3.135	3.3	3.465	See part numbering guide for options.
Current (I <sub>DD</sub> ) 2.5V Option	mA			65	
Current (I <sub>DD</sub> ) 3.3V Option	mA			70	
Current Voltage (V <sub>c</sub> ) 2.5V Option	V	0		2.5	
Current Voltage (V <sub>c</sub> ) 3.3V Option	V	0		3.3	
Pullability	ppm	$\pm 50$	$\pm 100$	$\pm 150$	See part numbering guide for options.
Linearity	%			10	
Output Load (LVDS)	$\Omega$			100	
Output Logic HIGH Level (V <sub>OH</sub> )	V		1.43	1.6	
Output Logic LOW Level (V <sub>OL</sub> )	V	0.9	1.1		
Differential Output Voltage (V <sub>OD</sub> )	mV	247	330	454	
Differential Output Error (pV <sub>OD</sub> )	mV			50	
Offset Voltage (V <sub>OS</sub> )	V	1.125	1.250	1.375	
Offset Error (pV <sub>OS</sub> )	mV			50	
Rise (T <sub>r</sub> ) And Fall (T <sub>f</sub> ) Time	ns			1	
Symmetry (Duty Cycle)	%	45	50	55	
Tri-State Input Voltage - Enable	V	0.7*V <sub>DD</sub>			
Tri-State Input Voltage - Disable	V			0.3*V <sub>DD</sub>	
Start-Up Time	ms			10	
Phase Jitter (12KHz ~ 20MHz)	ps		0.7	1.5	

**Outline Drawing & Land Pattern**

All dimensions are in millimeters (mm) unless otherwise noted. Drawings are not to scale.

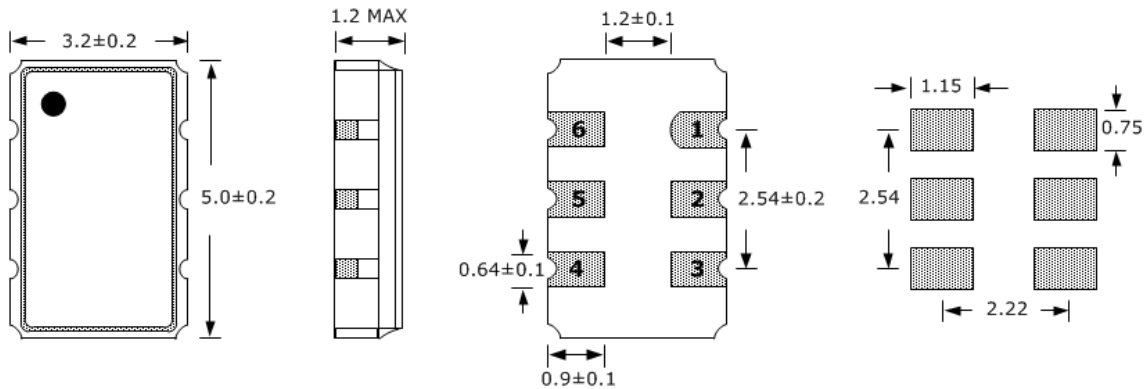

PIN	FUNCTION
1	TRI-STATE or NC
2	E/D or NC
3	GND
4	OUTPUT
5	COMP OUTPUT
6	V <sub>DD</sub>

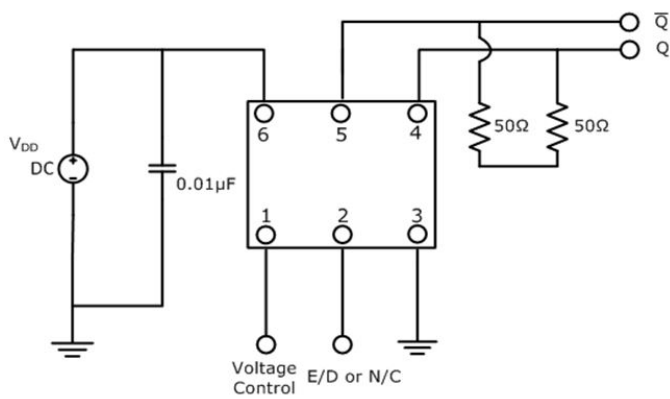
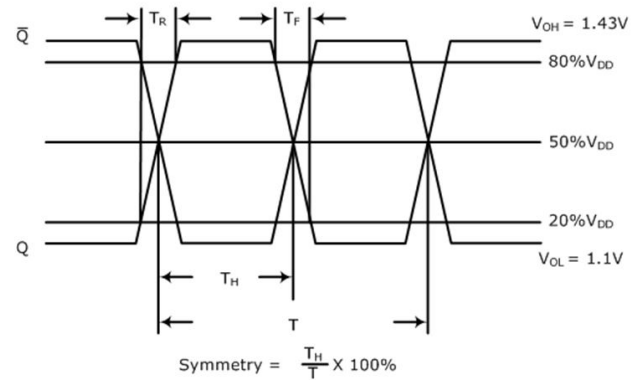
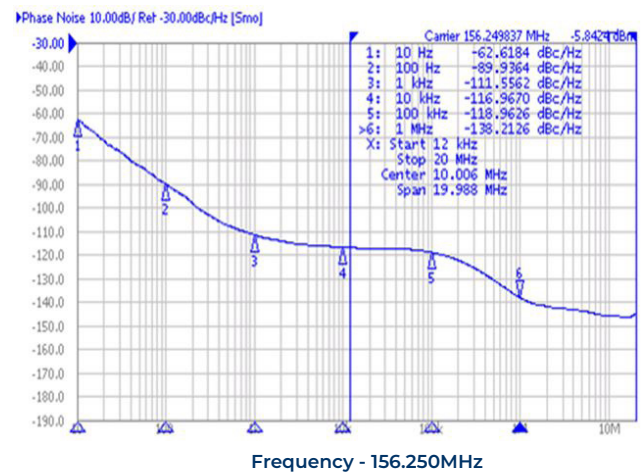
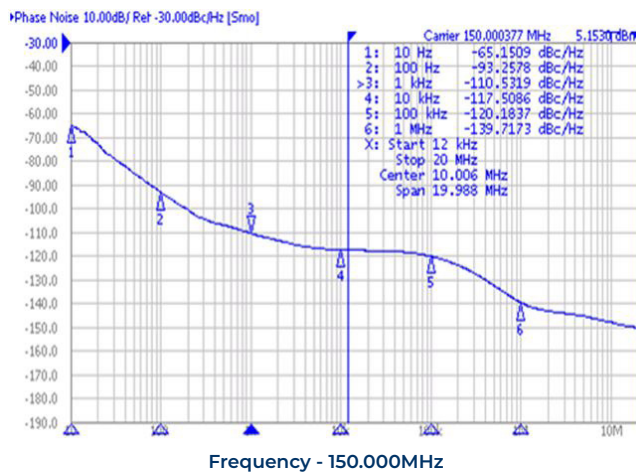
**Test Circuit (LVDS)**

**Waveform (LVDS)**

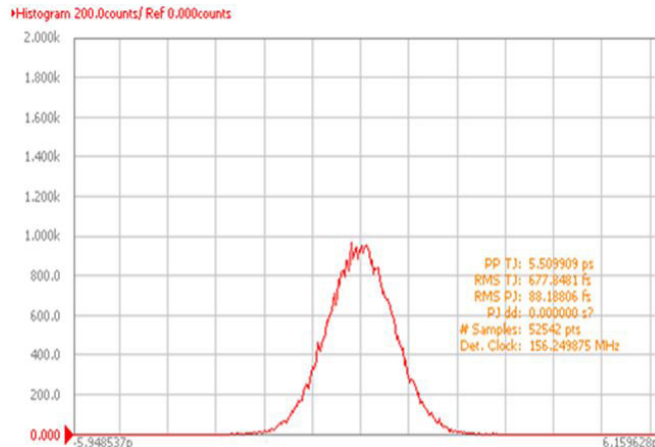
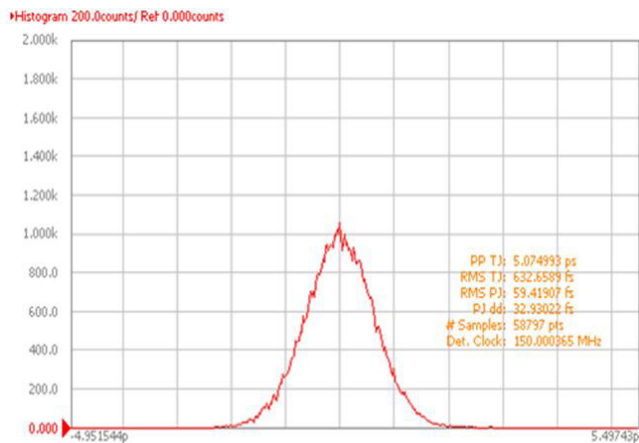
**Typical Phase Noise Performance (Measured By Agilent E5052A)**

Typical Jitter Performance (Measured By Agilent E5052A)

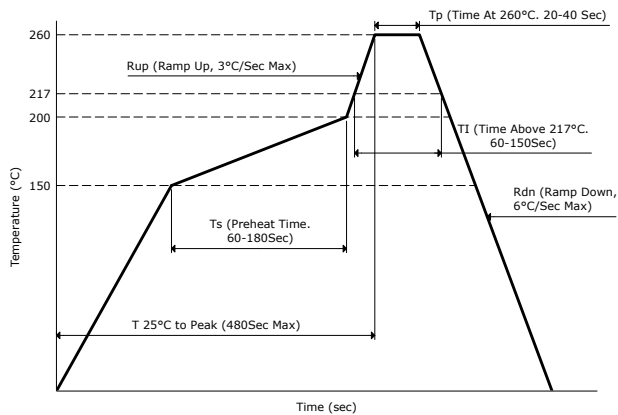

Reflow Profile



Part Marking

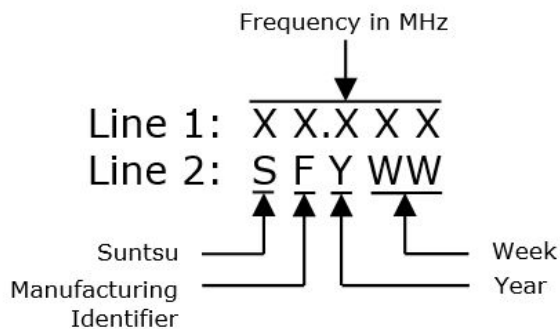

Tape And Reel Dimensions

All dimensions are in millimeters (mm) unless otherwise noted. Drawings are not to scale.

1,000pcs/Reel

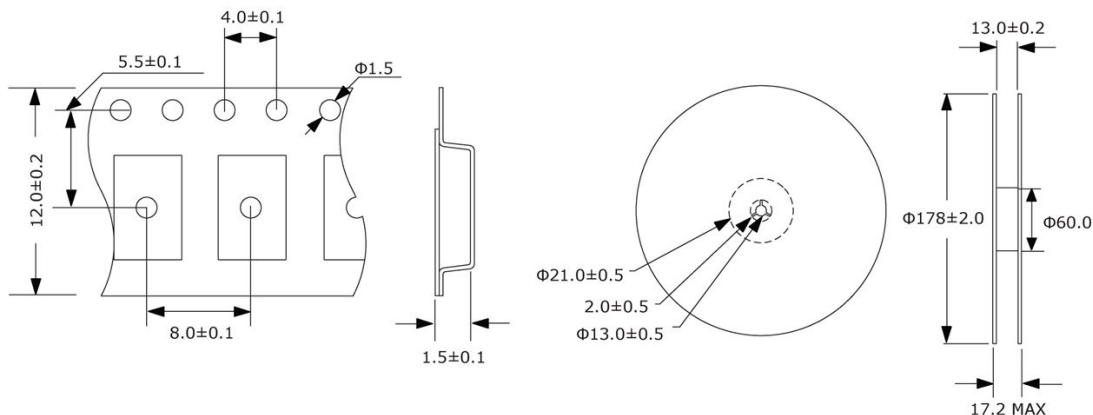

Environmental Specifications		Mechanical Specifications	
Temperature Cycling	MIL-STD-883, Method 1010, Condition B	Mechanical Shock	MIL-STD-202, Method 213, Condition B
Fine Leak Test	MIL-STD-883, Method 1014, Condition A	Vibration	MIL-STD-883, Method 2007, Condition A
Gross Leak Test	MIL-STD-883, Method 1014, Condition C	Moisture Resistance	MIL-STD-883, Method 1004
Solderability	MIL-STD-883, Method 2003	Resistance to Solvents	MIL-STD-202, Method 215
Moisture Sensitivity	J-STD-020, MSL 1	Resistance to Soldering Heat	MIL-STD-202, Method 210, Condition K