

# RK08H Without Knob Type

Compact type potentiometer suitable for volume and tone controls

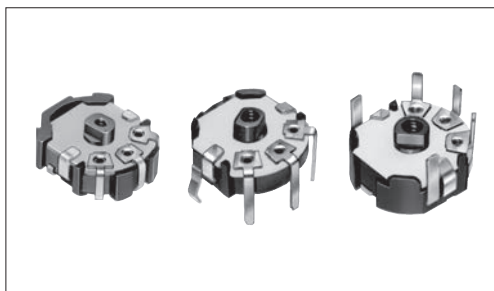

## Typical Specifications



Items	Specifications
Total resistance tolerance	±30%
Maximum operating voltage	50V AC 20V DC (Single-unit only)
Total rotational angle	200° ± 10°
Rotational torque	1 to 10mN·m 0.5 to 10mN·m (Reflow type)
Operating life	Without detent 10,000 cycles With detent 5,000 cycles
Operating temperature range	-10°C to +60°C

## Product Line

Number of resistor elements	Mounting direction	Length of the shaft (mm)	Center detent	Total resistance(kΩ)	Resistance taper	Soldering	Minimum order unit (pcs.)		Products No.	Drawing No.
							Japan	Export		
Single-unit	Vertical type	1	Without	50	1B	Manual	100	100	RK08H11100U3	1
				10					RK08H11100UD	
		100	15A	RK08H11100XC						
		4.5		With	RK08H1110A04					
	Back-to-back mounting type	1	Without	5	1B	Reflow	1,000	1,000	RK08H11100X7	2
				10					RK08H1120A05	3
Dual-unit	Vertical type	1	Without	50	15A	Manual	100	100	RK08H113003Q	4
				10					RK08H113003G	
		10	15C	RK08H12100GP						
		50		15A	RK08H12100F3					
	Back-to-back mounting type	1	-	50	15C	Reflow	1,000	1,000	RK08H122005A	3
				Vertical type					RK08H123002K	4

## Notes

1. Other varieties are also available. Refer to "Other Specifications" (P.376).
2. Dip soldering can be applied to the above products. Please specify if required Back-to-back mounting types are excluded.
3. We recommend print boards with a thickness of 0.8mm to 1.2mm. For 1.6mm thickness board applications, please contact us.

## Packing Specifications

Bulk / Taping

Soldering	Packing specifications	Number of packages (pcs.)			Tape width (mm)	Export package measurements (mm)
		1 reel	1 case / Japan	1 case / export packing		
Manual	Bulk	—	5,000	10,000	—	368×530×180
Reflow	Taping	1,000	4,000	4,000	16	397×401×139

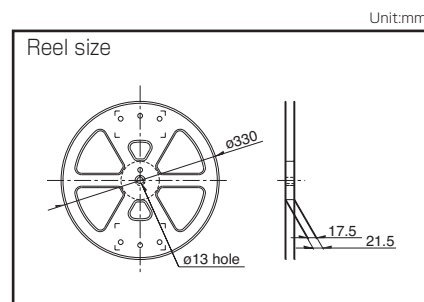





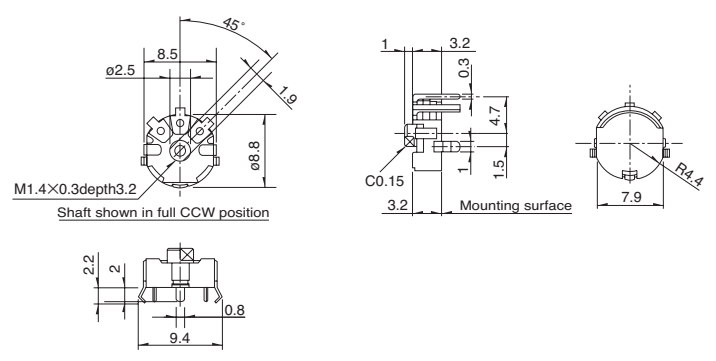

Refer to P.376 for other specifications.  
Refer to P.376 for soldering conditions.  
Refer to P.382 for ordering products not listed.

# RK08H Without Knob Type

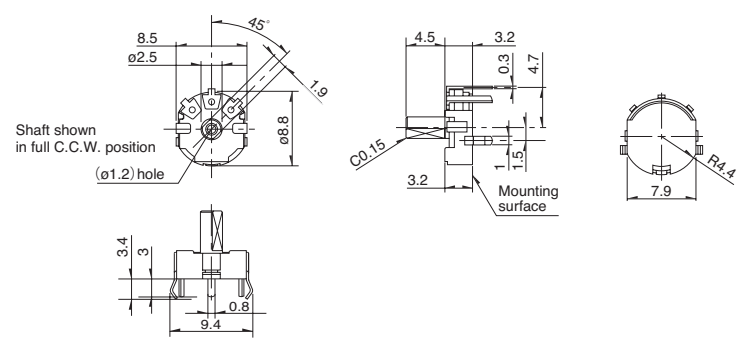
## Dimensions

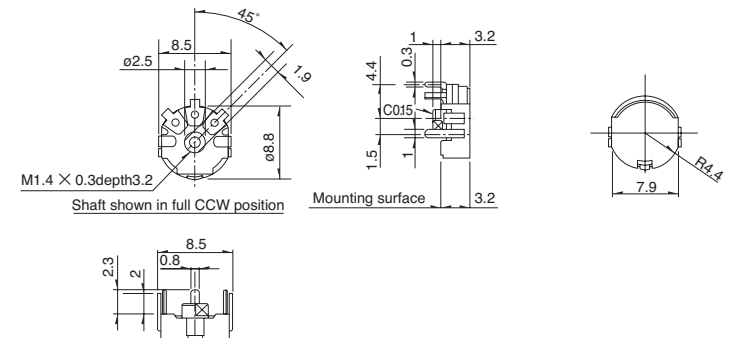
Unit:mm

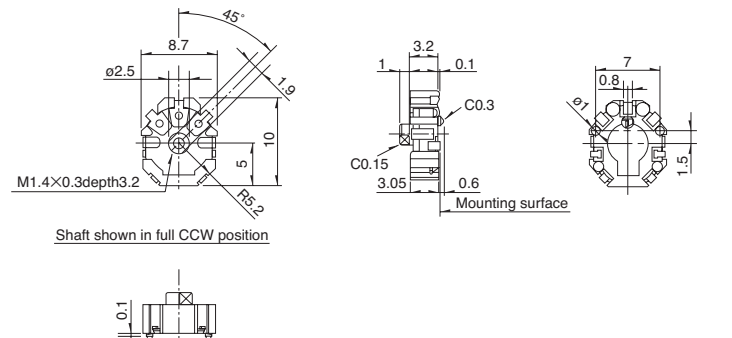
No.	Photo	Style
1	<p><b>Vertical Type</b>  <b>Single-shaft, single-unit</b>                      RK08H1110  <b>Single-shaft, dual-unit</b>                      RK08H1210</p> 	 <p>M1.4×0.3depth3.2                      Shaft shown in full CCW position</p>
2	<p><b>Vertical Type</b>  <b>Single-shaft, single-unit</b>                      RK08H1110</p> 	 <p>Shaft shown in full C.C.W. position (ø1.2) hole</p>
3	<p><b>Back-to-back mounting type</b>  <b>Single-shaft, single-unit</b>                      RK08H1120  <b>Single-shaft, dual-unit</b>                      RK08H1220</p> 	 <p>M1.4 × 0.3depth3.2                      Shaft shown in full CCW position</p>
4	<p><b>Reflow-type</b>  <b>Single-shaft, single-unit</b>                      RK08H1130  <b>Single-shaft, dual-unit</b>                      RK08H1230</p> 	 <p>M1.4×0.3depth3.2                      Shaft shown in full CCW position</p>

■ PC Board Mounting Hole Dimensions / Terminal Layout  
Vertical type (Viewed from mounting side)

Unit:mm

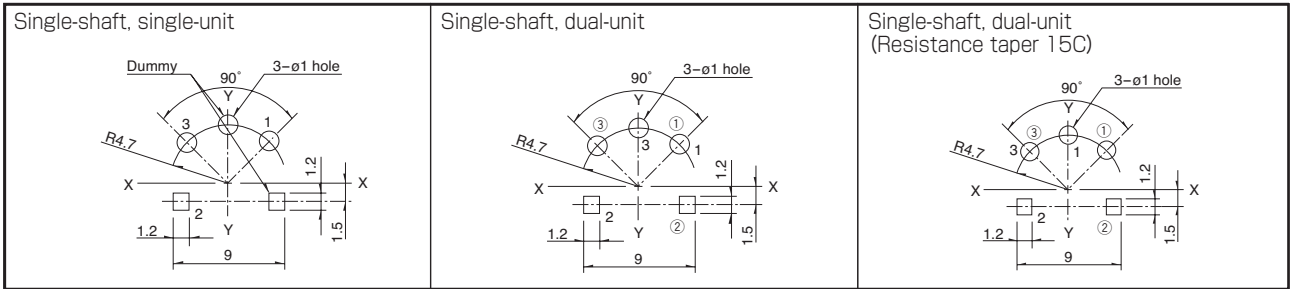

Back-to-back mounting type (Viewed from shaft side)

Unit:mm

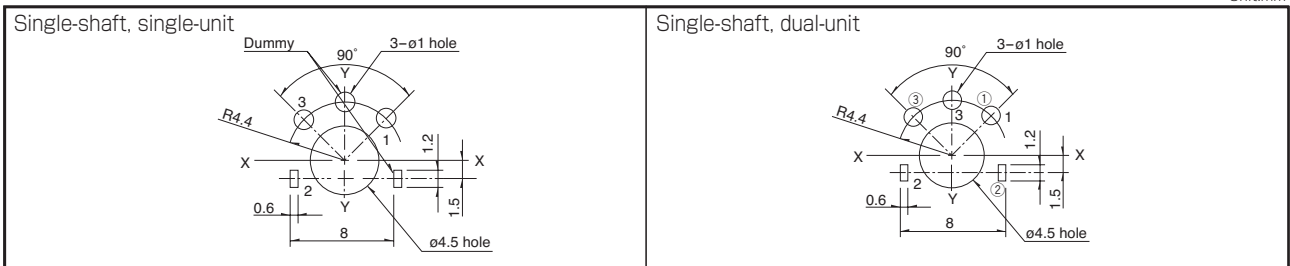

Reflow-type (Viewed from mounting side)

Unit:mm

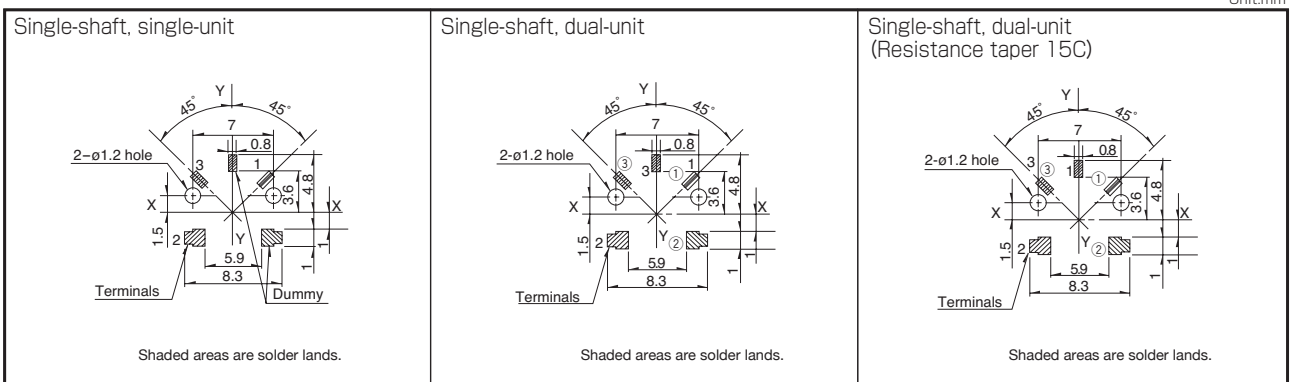

Note

Keep the DUMMY terminal open in the circuit.

■ Standard Specification Circuit Diagram

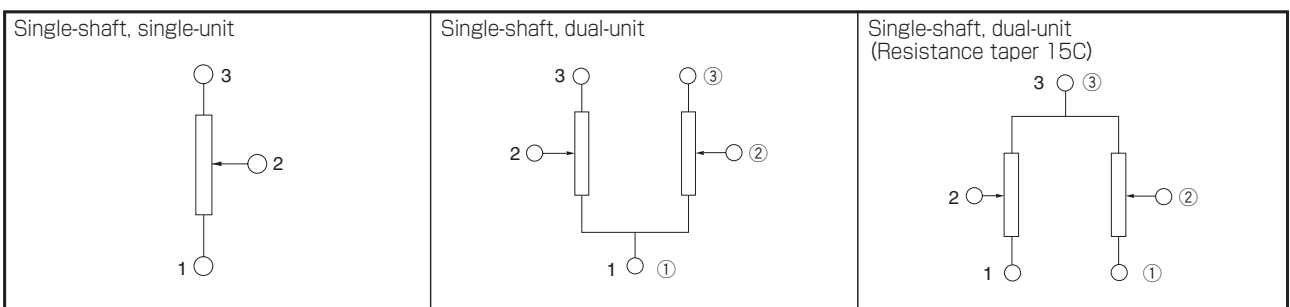

Rotary Potentiometers  
 Slide Potentiometers  
 Metal Shaft  
 Insulated Shaft  
 Knob Operating  
 Ring Type

# Without Knob Type / Other Specifications

In addition to the products listed, we can accommodate the follow specifications.

## Total Resistance Variety

Total resistance (k Ω)	5	10	20	50	100
------------------------	---	----	----	----	-----

## Resistance Taper

Resistance taper	15A	1B	3B	15C
------------------	-----	----	----	-----

# Without Knob Type / Ordering Products Not Listed

When ordering product varieties that are not listed, specify referring to the examples below.

## Sample Part Number

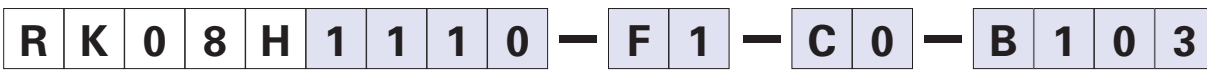

Model type

Code	Model type
111	Single-unit Vertical type
112	Single-unit Back-to-back mounting type
113	Single-unit Reflow type
121	Dual-unit Vertical type
122	Dual-unit Back-to-back mounting type
123	Dual-unit Reflow type

Length of the shaft (mm)

Code	Length of the shaft
F1	1
F4	4.5

\*Only 1mm types are provided with the M1.4 tap screws.  
\*Reflow soldering cannot be applied in the 4.5 mm type.

Detent

Code	Center detent
C0	Without
C1	With

\*Detent can only be specified for non-reflow single-unit types.

Resistance taper

Code	Resistance taper	Code	Resistance taper
A	15A	C	15C
B	1B	V	3B

Total resistance

Code	Total resistance (k Ω)	Code	Total resistance (k Ω)
502	5	503	50
103	10	104	100
203	20	—	—





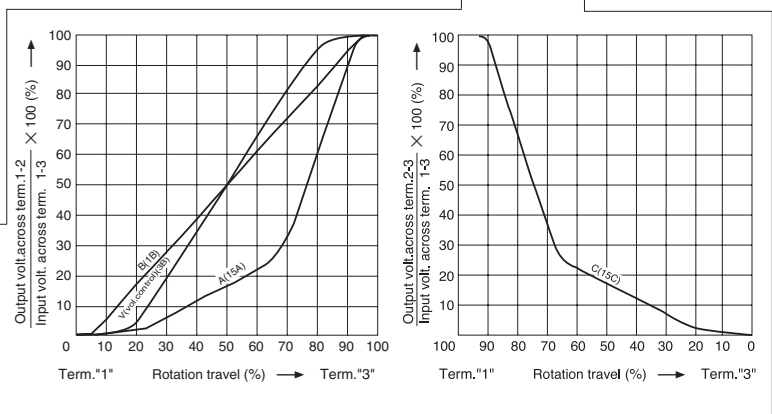





## Note

Marked are specifications recommended by ALPS.



# Knob Operating Type Potentiometers

## List of Varieties

Type	Without knob type			With knob type				
Series	RK08H1 □ 1	RK08H1 □ 2	RK08H1 □ 3	RK10J1 □ E	RK10J1 □ R	RK14J1 □ A	RK14J1 □ R	
	Single-unit/Dual-unit	Single-unit/Dual-unit	Single-unit/Dual-unit	Single-unit/Dual-unit	Single-unit/Dual-unit	Single-unit/Dual-unit	Single-unit/Dual-unit	
Photo								
Terminal orientation	Vertical	Back-to-back mounting	Reflow type	—	—	—	—	
Operating temperature range	-10°C to +60°C					-25°C to +70°C		
Operating life	Without detent 10,000 cycles With detent 5,000 cycles			10,000 cycles				
Automotive use	—	—	—	—	—	—	—	
Life cycle								
Electrical performance	Total resistance (kΩ)	5, 10, 20, 50, 100		10, 20, 50, 100				
	Resistance taper	15A, 1B, 3B, 15C						
	Rated power	0.03W						
	Insulation resistance	—	—	—	100MΩ min. 100V DC			
	Voltage proof	—	—	—	100V AC for 1minute			
Mechanical performance	Detent	Without / Center detent			Without			
	Stopper strength	0.1N			70mN·m			
	Push-pull strength	10N			5N			
	Vibration	—	—	—	—	—	※	
Terminal style	Insertion		Reflow	Insertion	Reflow	Insertion	Reflow	
Page	373			377				

### Residual Resistance

※ Applies only to products with specified residual resistance

Nominal total resistance	※ Residual resistance
100kΩ ≥ R ≥ 50kΩ	0.1% or less of nominal total resistance
50kΩ > R > 10kΩ	30Ω or less
10kΩ ≥ R	20Ω or less

### Maximum Attenuation

Nominal total resistance	Maximum attenuation
R ≥ 100kΩ	90dB min.
100kΩ > R ≥ 50kΩ	80dB min.
50kΩ > R ≥ 10kΩ	70dB min.
10kΩ > R	60dB min.

Knob Operating Type Potentiometers Soldering Conditions	382
Potentiometers Cautions	427
Potentiometers Measurement and Test Methods	429
Potentiometers Resistance Taper	431

※10 to 55 to 10Hz/min., the amplitude is 1.5mm for all the frequencies, in the 3 direction of X, Y and Z for 2 hours respectively

## Reference for Manual Soldering

Series	Tip temperature	Soldering time	No. of solders
<b>RK08H1□1, RK08H1□2, RK10J, RK14J</b>	350°C max.	3s max.	1 time

## Reference for Dip Soldering

Series	Preheating		Dip soldering		No. of solders
	Soldering surface temperature	Heating time	Soldering temperature	Soldering time	
<b>RK14J1□A</b>	80 to 120°C	70±30s	260°C±5°C	4±1s	1 time

## Example of Reflow Soldering Condition

Temperature profile

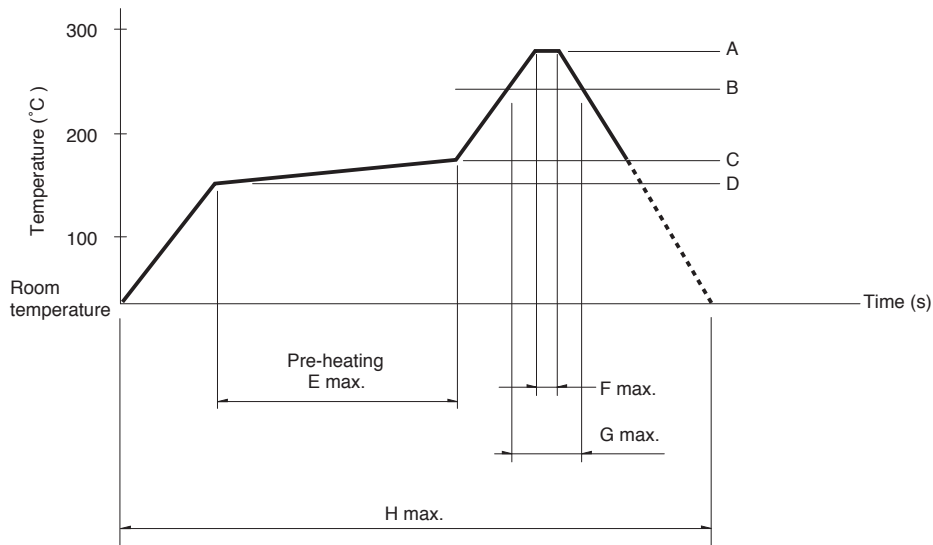

Series	A	B	C	D	E	F	G	H	No. of reflows
<b>RK08H1□3, RK10J1□R, RK14J1□R</b>	250°C	200°C	150°C	150°C	2 min.	3s	40s	4 min.	2 time max.

## Notes

1. When using an infrared reflow oven, solder may sometimes not be applied. Be sure to use a hot air reflow oven or a type that uses infrared rays in combination with hot air.
2. The temperatures given above are the maximum temperatures at the terminals of the potentiometer when employing a hot air reflow method. The temperature of the PC board and the surface temperature of the potentiometer may vary greatly depending on the PC board material, its size and thickness. Ensure that the surface temperature of the potentiometer does not rise to 250°C or greater.
3. Conditions vary to some extent depending on the type of reflow bath used. Be sure to give due consideration to this prior to use.