

Series 801 Hermetic Receptacles



Series 801 Hermetic Receptacles feature 304L stainless steel shells, fused vitreous glass insulators and Alloy 52 iron alloy contacts.

1 X 10⁻⁶ cc/second maximum Helium leak rate.

Three Shell Styles: solder mount, jam nut or square flange.

Solder Cup Contacts or **PC Tail Contacts** for attachment to flexible or rigid circuits or rigid boards.

Series 801 Solder Mount Hermetic

HOW TO ORDER

Sample Part Number

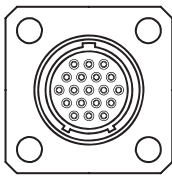
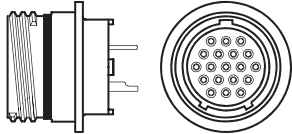
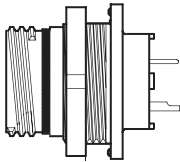
801-012	-03	Z1	7-10	P	A
Series	Shell Style	Shell Material / Finish	Shell Size/Insert Arrangement	Contact Type	Shell Key Position
801-012 Double-Start Hermetic Receptacles with Printed Circuit Board Contacts or Solder Cup Contacts	 -02 Square Flange	Z1 Stainless Steel / Passivated ZB Stainless Steel with Olive Drab Cadmium Finish	5-3 3 #23	P Pin, Solder Cup	A Normal
			6-1 1 #16		
			6-4 4 #23		
			6-7 7 #23		
			7-1 1 #12		
			7-10 10 #23		
	 -03 Solder Mount		8-13 13 #23	C Pin, PC Tail	B Pos. B
			9-4 4 #16		
			9-19 19 #23		
			10-26 26 #23		
			13-2 2 #12		
			13-37 37 #23		
 -07 Jam Nut	16-55 55 #23	D Pos. C			
	17-85 85 #23				

Series 801 Hermetic Jam Nut Receptacles

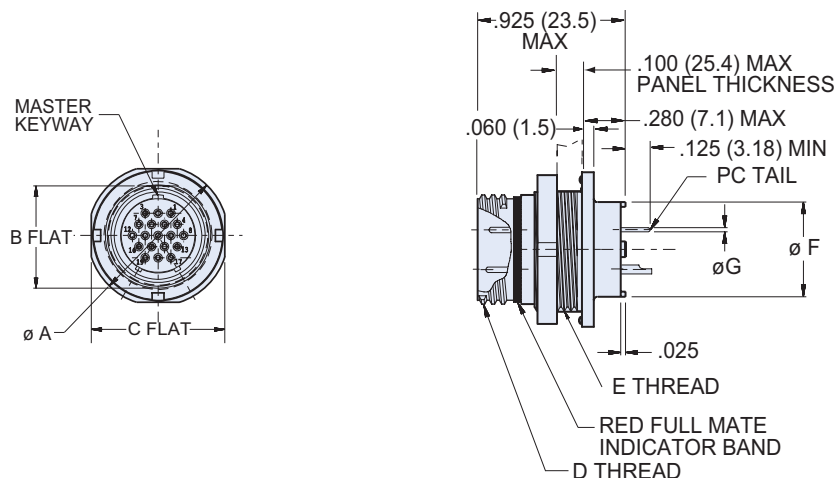

DIMENSIONS

Shell Size	Ø A		B Flat		C Flat		D Thread	E Thread UN-2A	Ø F		Ø G Tail Dia.
	In.	mm.	In.	mm.	In.	mm.			In.	mm.	
5	.575	14.61	.350	8.89	.545	13.84	.3125-.05P-.1L-2A	.375-28	.244	6.20	#23
6	.635	16.13	.410	10.41	.595	15.11	.375-.05P-.1L-2A	.4375-28	.330	8.38	.018/.022 (0.46/0.56)
7	.755	19.18	.536	13.61	.723	18.36	.4375-.05P-1L2A	.5625-32	.432	10.97	
8	.755	19.18	.536	13.61	.723	18.36	.5000-.05P-1L-2A	.5625-32	.493	12.52	#16
9	.830	21.08	.596	15.14	.790	20.07	.5625-.05P-.1L-2A	.625-28	.551	14.00	.060/.064 (1.52/1.63)
10	.890	22.61	.658	16.71	.855	21.72	.6250-.05P-1L-2A	.6875-28	.620	15.75	
13	1.078	27.38	.845	21.46	1.044	26.52	.8125-.1P-.2L-2a	.875-28	.703	17.86	#12
16	1.264	32.11	1.022	25.96	1.230	31.24	1.000-.1P-.2L-2A	1.0625-20	.863	21.92	.092/.096 (2.34/2.44)
17	1.325	33.66	1.096	27.84	1.290	32.77	1.062-.1P-.2L-2A	1.125-28	.912	23.16	

PANEL CUTOUT

Shell Size	A Flat		Ø B	
	In. ± .002	mm. ± 0.05	In.	mm.
5	.360	9.14	.385	9.78
6	.420	10.67	.448	11.37
7	.551	14.00	.573	14.55
8	.551	14.00	.573	14.55
9	.609	15.47	.635	16.13
10	.671	17.04	.698	17.73
13	.859	21.82	.885	22.48
16	1.038	26.37	1.075	27.31
17	1.111	28.22	1.135	28.83

KEY POSITIONS

Receptacle Key Positions

	A°	B°
A	150°	210°
B	75°	210°
C	95°	230°
D	140°	275°

Series 801 Hermetic Square Flange Receptacles

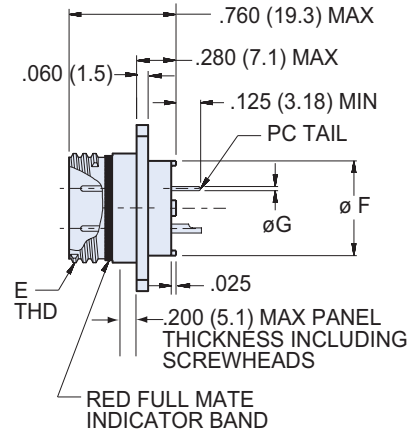
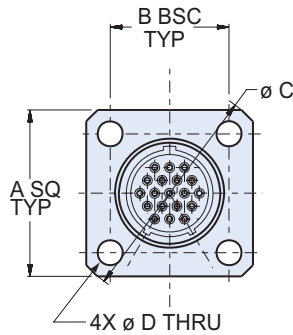

DIMENSIONS

Shell Size	A Max		B BSC		Ø C		Ø D		E Thread	Ø F		Ø G Tail Dia
	In.	mm.	In.	mm.	In.	mm.	In. ±.003	mm. ± 0.08		In.	mm.	
5	.530	13.46	.363	9.22	.680	17.27	.093	2.36	.3125-.05P-1L-2A	.244	6.20	#23
6	.590	14.99	.423	10.74	.750	19.05	.093	2.36	.375-.05P-1L-2A	.330	8.38	.018/.022 (0.46/0.56)
7	.650	16.51	.483	12.27	.850	21.59	.093	2.36	.4375-.05P-1L2A	.432	10.97	
8	.712	18.08	.545	13.84	.938	23.83	.093	2.36	.5000-.05P-1L2A	.493	12.52	#16
9	.850	21.59	.607	15.42	1.125	28.58	.128	3.25	.5625-.05P-1L-2A	.551	14.00	.060/.064 (1.52/1.63)
10	.890	22.61	.670	17.02	1.188	30.18	.128	3.25	.6250-.05P-1L2A	.620	15.75	
13	1.030	26.16	.812	20.62	1.375	34.93	.128	3.25	.8125-.1P-.2L-2A	.703	17.86	#12
16	1.219	31.96	.981	24.92	1.625	41.28	.128	3.25	1.000-.1P-.2L-2A	.863	21.92	.092/.096 (2.34/2.44)
17	1.280	32.51	1.060	26.92	1.700	43.18	.128	3.25	1.062-.1P-.2L-2A	.912	23.16	

PANEL CUTOUT

Shell Size	Ø A		Ø B		Ø C	
	In.	mm.	In.	mm.	In.	mm.
5	.330	8.38	.363	9.22	.093	2.36
6	.390	9.91	.423	10.74	.093	2.36
7	.450	11.43	.483	12.27	.093	2.36
8	.510	12.95	.545	13.84	.093	2.36
9	.575	14.61	.607	15.42	.128	3.25
10	.640	16.26	.670	17.02	.128	3.25
13	.825	20.96	.812	20.65	.128	3.25
16	1.015	25.78	.981	24.92	.128	3.25
17	1.075	27.31	1.060	26.92	.128	3.25

KEY POSITIONS

Receptacle Key Positions

	A°	B°
A	150°	210°
B	75°	210°
C	95°	230°
D	140°	275°

Series 801 Hermetic Solder Mount Receptacle

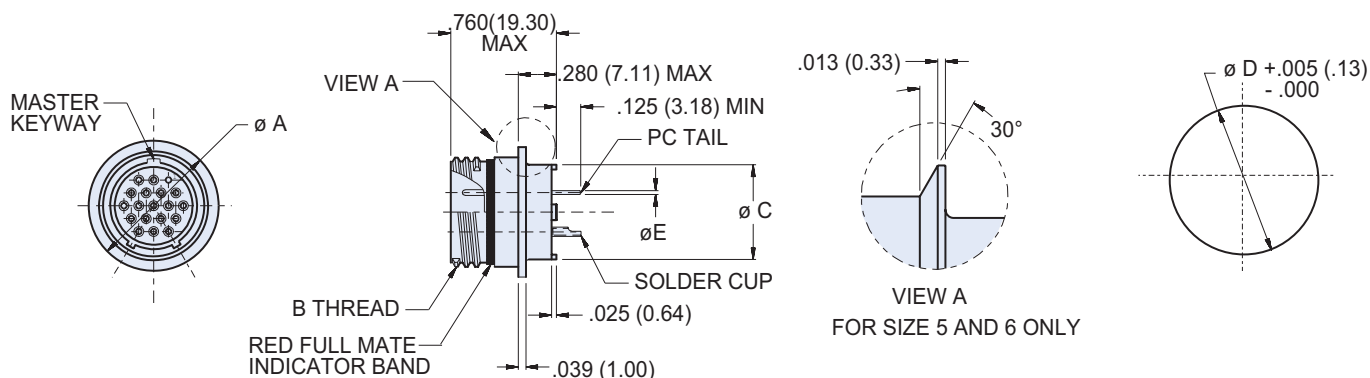

Solder Mount Hermetic
801-012-03

DIMENSIONS

Shell Size	Ø A		B Thread	Ø C		Ø D Panel Cutout		Ø L Tail Dia.
	In.	mm.		In.	mm.	In.	mm.	
5	.395	10.03	.3125-.05P-.1L-2A	.244	6.20	.319	8.10	#23
6	.455	11.56	.375-.05P-.1L-2A	.330	8.38	.376	9.55	.018/.022 (0.46/0.56)
7	.520	13.21	.4375-.05P-1L-2A	.432	11.97	.438	11.13	
8	.580	14.73	.5000-.05P-1L-2A	.493	12.52	.438	11.13	#16
9	.645	16.38	.5625-.05P-.1L-2A	.551	14.00	.563	14.30	.060/.064 (1.52/1.63)
10	.705	18.01	.6250-.05P-1L-2A	.620	15.75	.438	11.13	
13	.895	22.73	.8125-.1P-.2L-2A	.703	17.86	.814	20.68	
16	1.080	27.43	1.000-.1P-.2L-2A	.863	21.92	1.007	25.58	.092/.096
17	1.145	29.08	1.062-.1P-.2L-2A	.912	23.16	1.067	27.10	(2.34/2.44)

KEY POSITIONS

Receptacle Key Positions

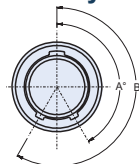

	A°	B°
A	150°	210°
B	75°	210°
C	95°	230°
D	140°	275°