

Technical Data Sheet

Top View LEDs

61-238/GBC-YX2Y2M/ET

Features

- Super-luminosity chip LED.
- White SMT package.
- Lead frame package with individual 6 pins.
- Wide viewing angle.
- Soldering methods: IR reflow soldering.
- Pb-free.
- The product itself will remain within RoHS compliant version.



Descriptions

- Due to the package design, 61-238 has wide viewing angle, and low power consumption. The white LED which was fabricated using blue LEDs and a phosphor, and the phosphor is excited by blue light and emits yellow fluorescence. The mixture of blue light and yellow light results in a white emission. And makes it ideal for light pipe application.

Applications

- Amusement equipment.
- Information boards.
- Flashlight for digital camera of cellular phone.

Device Selection Guide

Chip	Emitted Color	Resin Color
Material		
InGaN	Brilliant Green	Water Clear

Technical Data Sheet

Top View LEDs

61-238/GBC-YX2Y2M/ET

Package Outline Dimensions

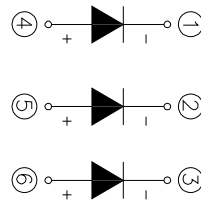
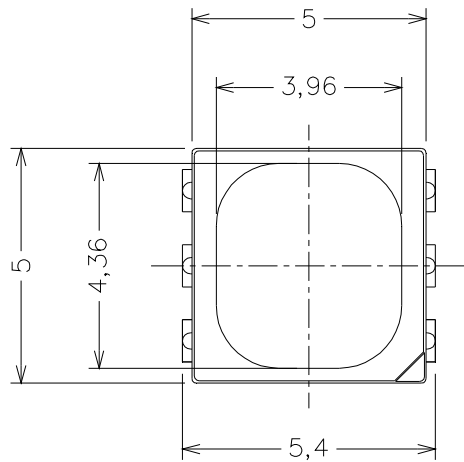

Polarity

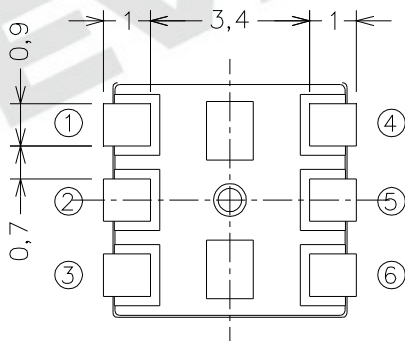
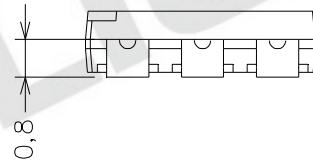
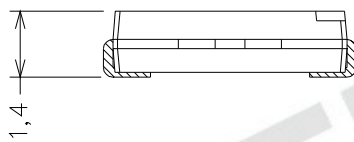

Bot. view

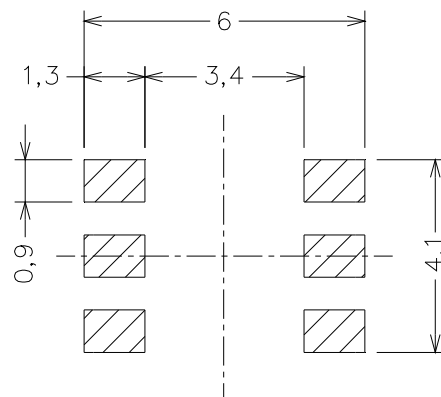

Soldering patterns

Note: The tolerances unless mentioned is ± 0.1 mm; Unit = mm

Technical Data Sheet

Top View LEDs

61-238/GBC-YX2Y2M/ET

Absolute Maximum Ratings (Ta=25)^{*1}

Parameter	Symbol	Rating	Unit
Reverse Voltage	V _R	5	V
Forward Current	I _F	30	mA
Peak Forward Current(Duty 1/10 @ 1KHz)	I _{FP}	100	mA
Power Dissipation	P _d	110	mW
Electrostatic Discharge(HBM)	ESD	1000	V
Operating Temperature	Topr	-40 ~ +85	
Storage Temperature	Tstg	-40~ +90	
Soldering Temperature	Tsol	Reflow Soldering : 260 Hand Soldering : 350	for 10 sec. for 3 sec.

* 1. The value are based on 1 die performance

Technical Data Sheet

Top View LEDs

61-238/GBC-YX2Y2M/ET

Electro-Optical Characteristics (Ta=25)

Parameter	Symbol	Min.	Typ.	Max.	Units	Condition
Luminous Intensity*1	I _v	2250	-----	4500	mcd	I _F =20mA*2
Viewing Angle*1	2 1/2	-----	120	-----	deg	I _F =20mA*2
Peak Wavelength*1	p	-----	518	-----	nm	I _F =20mA*2
Dominant Wavelength*1	d	520	-----	535	nm	I _F =20mA*2
Spectrum Radiation Bandwidth		-----	35	-----	nm	I _F =20mA
Forward Voltage	V _F	2.75	-----	3.95	V	I _F =20mA*2

*1. When three LED dies are operated simultaneously.

*2. For each die.

Notes:

1. Tolerance of Luminous Intensity $\pm 11\%$
2. Tolerance of Dominant Wavelength ± 1 nm
3. Tolerance of Forward Voltage $\pm 0.1V$

Technical Data Sheet

Top View LEDs

61-238/GBC-YX2Y2M/ET

Bin Range of Luminous Intensity

Bin Code	Min.	Max.	Unit	Condition
X2	2250	2850	mcd	$I_F^{*2}=20mA$
Y1	2850	3600		
Y2	3600	4500		

Bin Range of Dominant Wavelength

Group	Bin Code	Min.	Max.	Unit	Condition
Y	X	520	525	nm	$I_F=20mA*2$
	Y	525	530		
	Z	530	535		

Bin Range of Forward Voltage

Group	Bin	Min.	Max.	Unit	Condition
M	5	2.75	3.05	V	$I_F=20mA$
	6	3.05	3.35		
	7	3.35	3.65		
	8	3.65	3.95		

Notes:

- *2 For each die.
- Tolerance of Luminous Intensity $\pm 11\%$
- Tolerance of Dominant Wavelength ± 1 nm

Technical Data Sheet

Top View LEDs

61-238/GBC-YX2Y2M/ET

Typical Electro-Optical Characteristics Curves

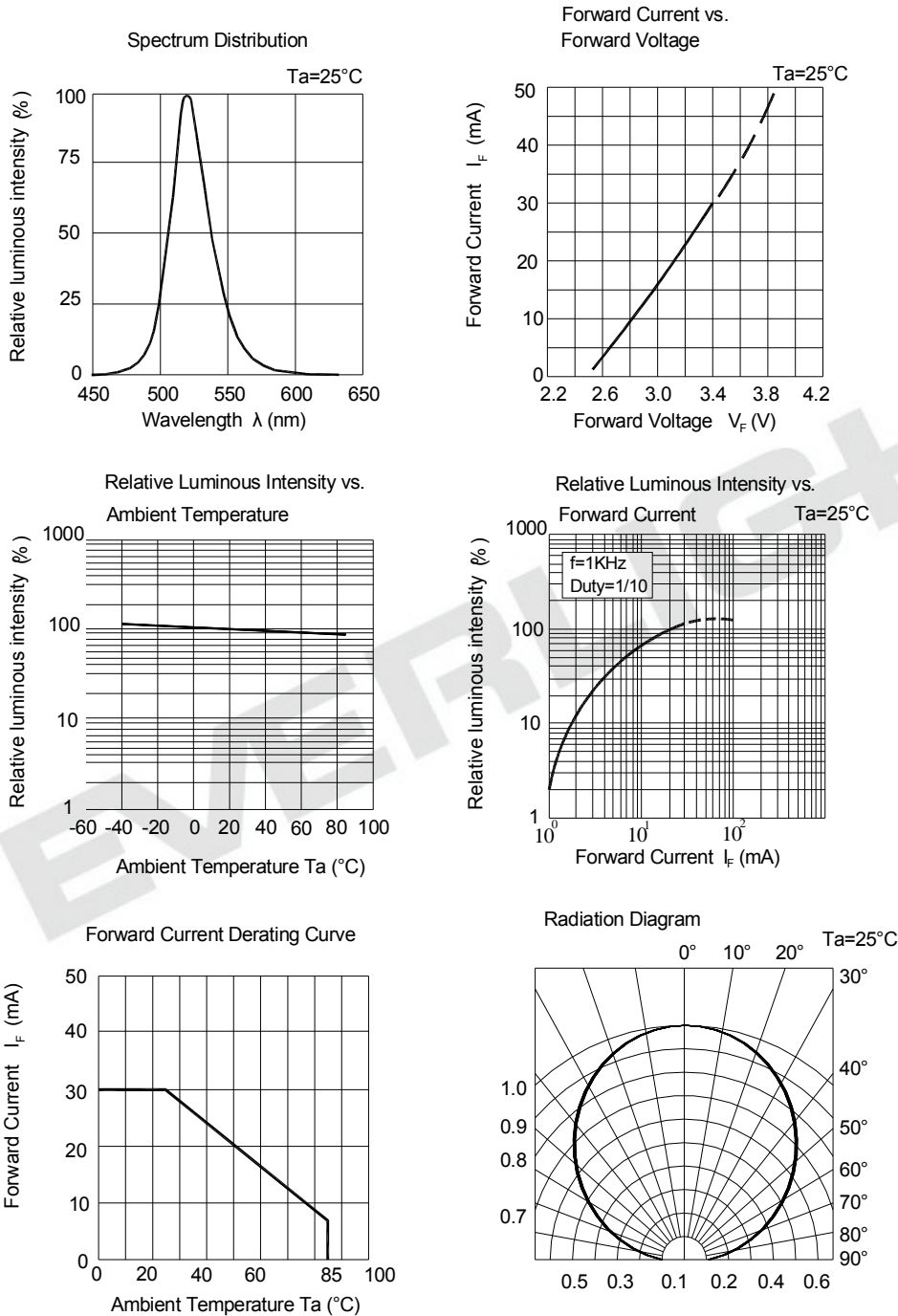

Technical Data Sheet

Top View LEDs

61-238/GBC-YX2Y2M/ET

Label Explanation

CAT: Luminous Intensity Rank

HUE: Dom. Wavelength Rank

REF: Forward Voltage Rank

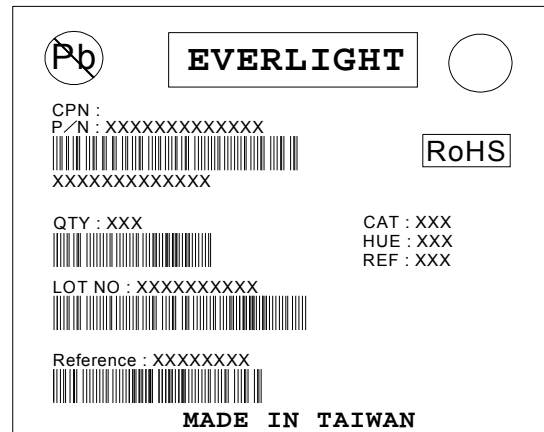

Reel Dimensions

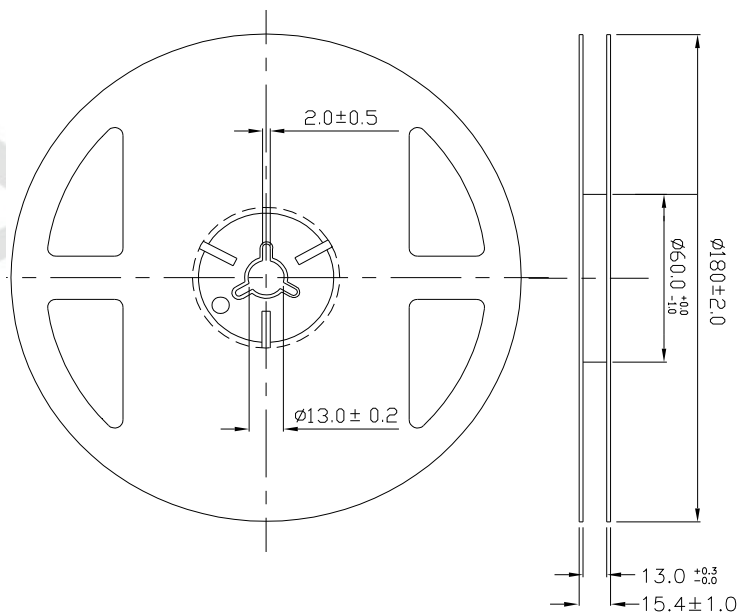

Note: Tolerance unless mentioned is ± 0.1 mm; Unit = mm

Technical Data Sheet

Top View LEDs

61-238/GBC-YX2Y2M/ET

Carrier Tape Dimensions: Loaded Quantity 800 pcs Per Reel

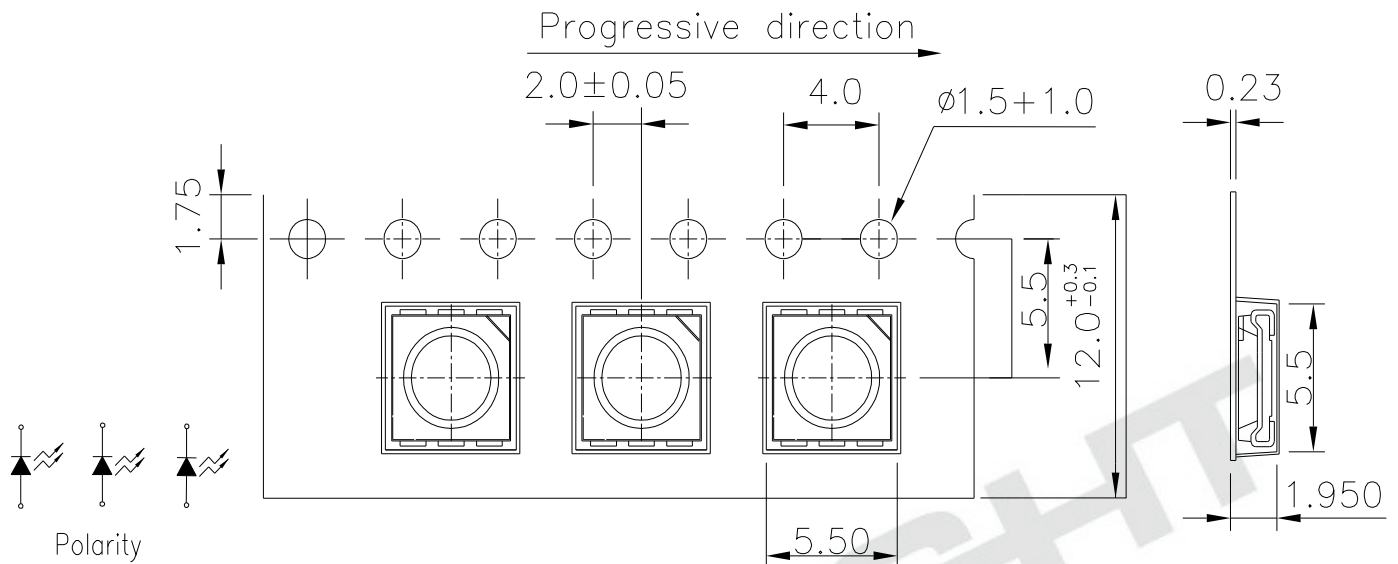

Note: Tolerances unless mentioned is ± 0.1 mm; Unit = mm

Moisture Resistant Packaging

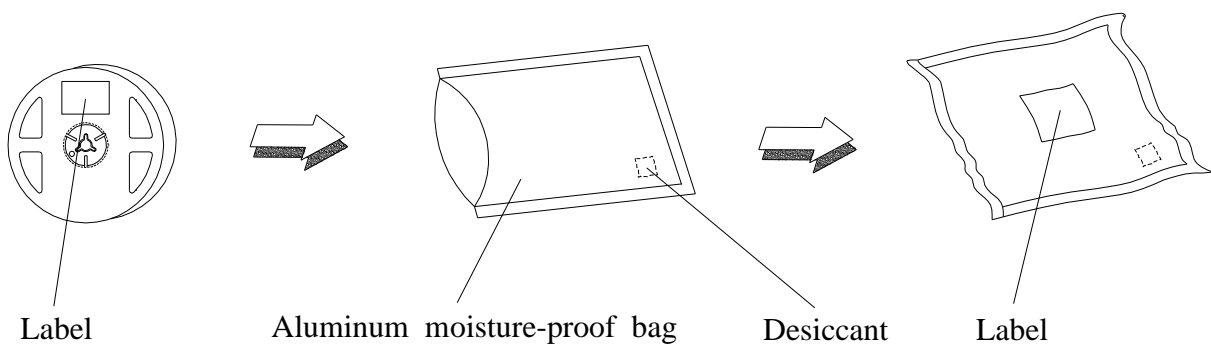

Technical Data Sheet

Top View LEDs

61-238/GBC-YX2Y2M/ET

Reliability Test Items and Conditions

The reliability of products shall be satisfied with items listed below.

Confidence level : 90%

LTPD : 10%

No.	Items	Test Condition	Test Hours/Cycles	Sample Size	Ac/Re
1	Reflow Soldering	Temp. : 260 ±5 Max. 10sec.	6 Min.	22 PCS.	0/1
2	Temperature Cycle	H : +100 15min 5 min L : -40 15min	300 Cycles	22 PCS.	0/1
3	Thermal Shock	H : +100 5min 10 sec L : -10 5min	300 Cycles	22 PCS.	0/1
4	High Temperature Storage	Temp. : 100	1000 Hrs.	22 PCS.	0/1
5	Low Temperature Storage	Temp. : -40	1000 Hrs.	22 PCS.	0/1
6	DC Operating Life	I _F = 20 mA	1000 Hrs.	22 PCS.	0/1
7	High Temperature / High Humidity	85 / 85%RH	1000 Hrs.	22 PCS.	0/1

Technical Data Sheet

Top View LEDs

61-238/GBC-YX2Y2M/ET

Precautions for Use

1. Over-current-proof

Customer must apply resistors for protection, otherwise slight voltage shift will cause big current change (Burn out will happen).

2. Storage

2.1 Do not open moisture proof bag before the products are ready to use.

2.2 Before opening the package: The LEDs should be kept at 30 or less and 90%RH or less.

2.3 After opening the package: The LED's floor life are 168 hours under 30 or less and 60% RH or less.

If unused LEDs remain, it should be stored in moisture proof packages.

2.4 If the moisture absorbent material (silica gel) has faded away or the LEDs have exceeded the storage time, baking treatment should be performed using the following conditions.

Baking treatment : 60±5 for 24 hours.

3. Soldering Condition

3.1 Pb-free solder temperature profile

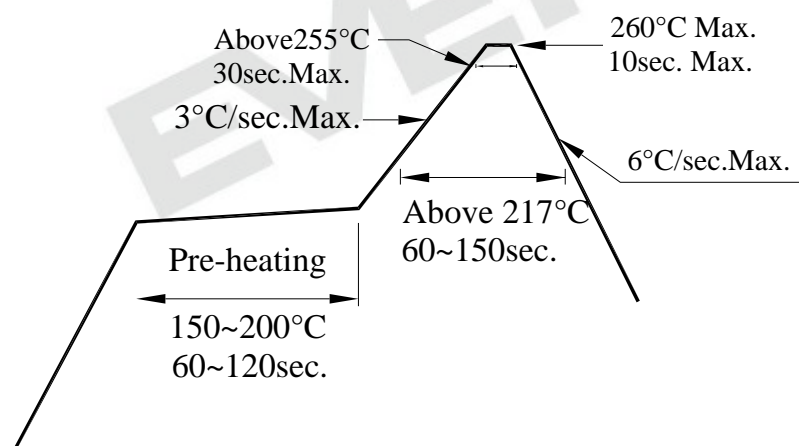

3.2 Reflow soldering should not be done more than two times.

3.3 When soldering, do not put stress on the LEDs during heating.

3.4 After soldering, do not warp the circuit board.

Technical Data Sheet

Top View LEDs

61-238/GBC-YX2Y2M/ET

4. Soldering Iron

Each terminal is to go to the tip of soldering iron temperature less than 350 for 3 seconds within once in less than the soldering iron capacity 25W. Leave two seconds and more intervals, and do soldering of each terminal. Be careful because the damage of the product is often started at the time of the hand solder.

5. Repairing

Repair should not be done after the LEDs have been soldered. When repairing is unavoidable, a double-head soldering iron should be used (as below figure). It should be confirmed beforehand whether the characteristics of the LEDs will or will not be damaged by repairing.

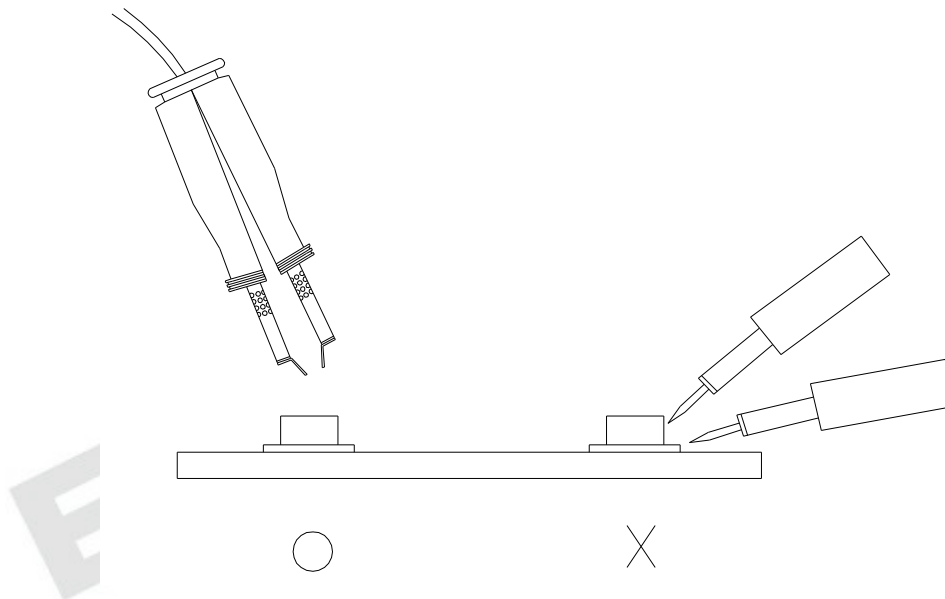

EVERLIGHT ELECTRONICS CO., LTD.
Office: No 25, Lane 76, Sec 3, Chung Yang Rd,
Tucheng, Taipei 236, Taiwan, R.O.C

Tel: 886-2-2267-2000, 2267-9936
Fax: 886-2267-6244, 2267-6189, 2267-6306
<http://www.everlight.com>