



AOJS100

100W AC/DC



Features

- Inrush Current Limit
- Wide Input voltage range
- Universal input 100-240 VAC
- Over voltage protection
- Overcurrent protection
- 3 Yr warranty



MODEL/CHANNEL		Unit	AOJS100-3.3	AOJS100-05	AOJS100-09	AOJS100-12	AOJS100-15	AOJS100-24	AOJS100-48	
OUTPUT	Nominal Voltage	V	3.3	5	9	12	15	24	48	
	Current	A	20	16	11	8.5	7	4.5	2.3	
	Rated Power	W	66	80	99	102	105	108	110	
	Ripple	mV	50	50	100	100	100	100	180	
	Line Regulations	mV	17	25	45	60	75	120	240	
	Load Regulations	mV	66	50	90	60	75	120	240	
	Temperature Drift	mV	50	75	135	180	225	360	720	
	Ripple & Noise(pk-pk) (*1)	mV	80	80	120	120	120	120	200	
	Turn-on Time typ.	ms	1200 (AC IN 110/220V, lo=100%)							
	Hold-up Time typ.	ms	14 (AC IN 110/220V, lo=100%)							
INPUT	Voltage Currency	V	AC100-240(AC88-264), 50/60Hz(47-440Hz) (Universal Input)							
	Current 110V Typical 220V	A	2.2 (lo=100%) 1.2 (lo=100%)							
	Efficiency 110V Typ. 220V	%	74	79	80	82	85	86	86	
	Inrush Current 110V Typical 220V	A	30 (Ta=25°C, Cold start) lo=100% 60 (Ta=25°C, Cold start) lo=100%							
Function	Over Voltage Protection	V	Works at 115~140% of rating							
	Over Current Protection (*2)	A	Works @110% of rating							
Electrical Isolation	Input - Output	-	AC 3KV 1min., cut-off: 20mA / DC 500V 100 MΩ							
	Input - F.G	-	AC 2KV 1min., cut-off: 20mA / DC 500V 100 MΩ							
	Output - F.G	-	AC 0.5 KV 1min., cut-off: 100mA / DC 500V 100 MΩ							
Environment	Operating temp. & Hum.	-	-10 ~+70°C (with derating, lo=100% to 50% when 50°C to 71°C) 20~90% RH (NON condensing)							
	Storage temp. & Humidity	-	-20 ~+75°C, 20~90% RH (NON condensing)							
	Vibration	-	10~55Hz @ 1G 3 minutes PERIOD, 30 minutes along X,Y & Z axis							
	Impact	-	10G for 20ms, once on each X,Y & Z axis							
Dimension	Size(LxWxH)/Weight	mm/g	159x97x38/600							
	Safety	-	Approved							
	Emission	-	Conducted Emission, Compiles with EN55022-B, FCC-B, EN55011							
	PFHC	-	Harmonic Current, Complies with IEC61000-3-2							





1. BLOCK DIAGRAM

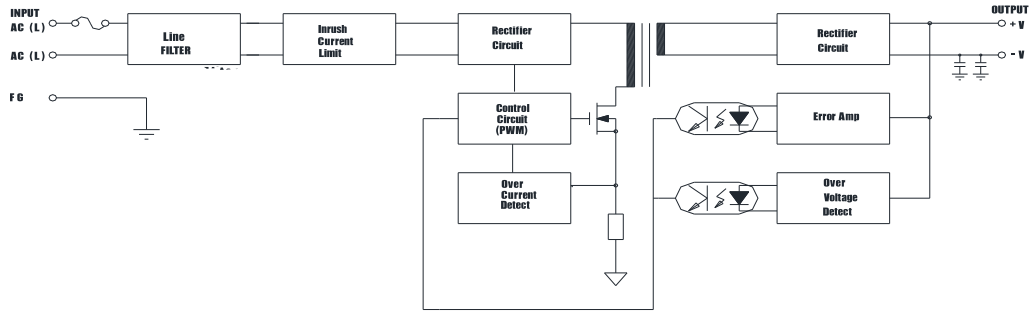

2. Terminal Connection

Mark	Pin Connection	Function
L	AC Live line	SMPS AC input Terminal (Fuse in Line)
N	AC Neutral line	SMPS AC input Terminal
F.G	Frame ground	SMPS AC Grounding, CASE Grounding
+V	DC Output (+)	DC (+) output Terminal
-V	DC Output (-)	DC (-) output Terminal

3. Function

3-1. Adjustable output voltage range

o Output voltage can be adjustable within $\pm 5\%$ but it could cause malfunction if it is out of Adjustable range

3-2. O.C.P : Over Current Protection

o Over current protection circuit is to be in operation to cut off the output in order to protect SMPS if output current exceeds over 110% of rated output current due to malfunction of application system or short-circuit of external connection.

3-3. O.V.P : Over Voltage Protection)

o Over voltage protection circuit is to be in operation to cut off the output in order to protect SMPS if output voltage exceeds over 115% of rated output voltage or reversal voltage occurs.

o Over voltage protection feature is to be off, once the system is restored after the problem for malfunction is resolved, followed by cutting off AC input power for 3 minutes. If output voltage is NOT restored to normal, however, it is highly recommended to consult with personnel at customer support to monitor possible internal damage to the product.





4. Series operation / Parallel operation

4-1. Both connection systems as shown at A (Fig 1.) or B (Fig 2.) can be used during series operation.

4-2. In parallel operation A at Figure 4, current capacity cannot be increased, while it should be used for backup only. Moreover, diode that is to be added during parallel operation should be selected after considering its voltage drop (V_f), output voltage (V_o) and current capacity (I_o).

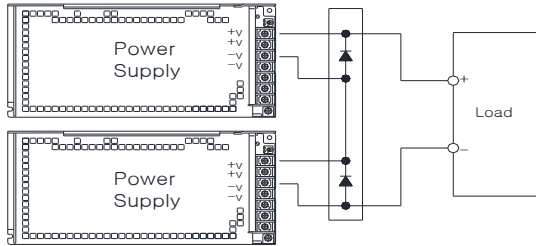

Fig 1.

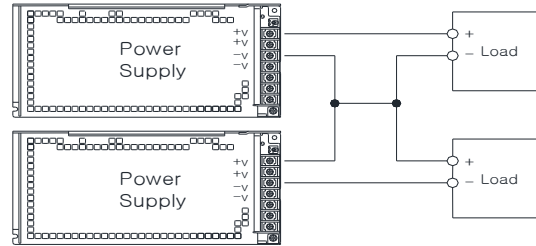

Fig 2.

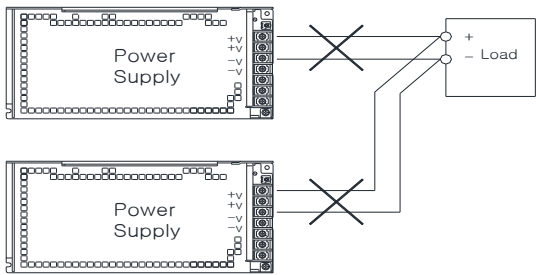

Fig 3.

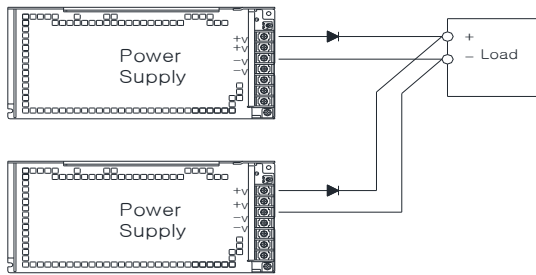

Fig 4.

5. Mounting method

5-1. It should be mounted as follow in the consideration of air cooling

- o Mounting method should be considered with airflow..
- o Leave enough spaces between units when several units mounted together
- o Forced air cooling makes protection against heat better



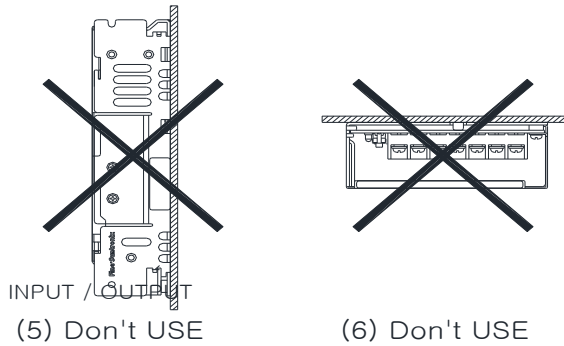
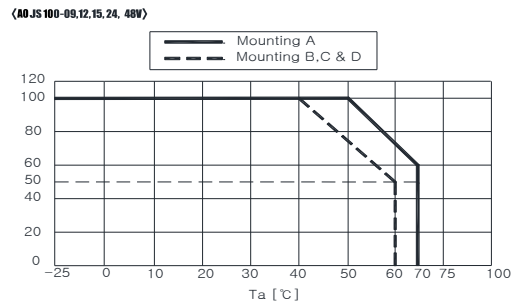
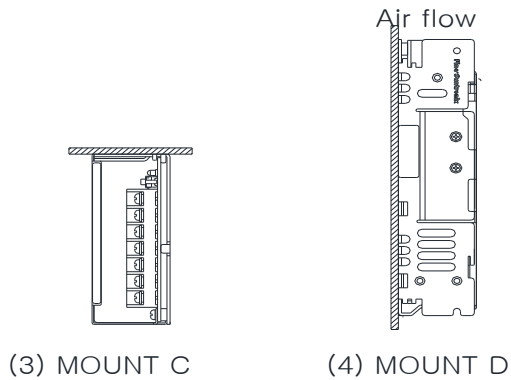
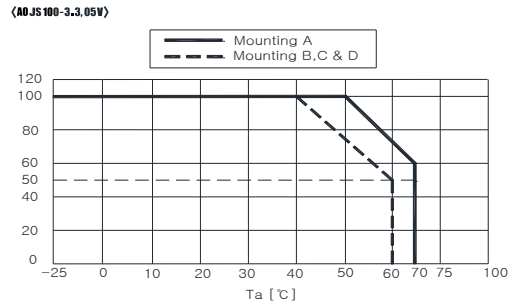
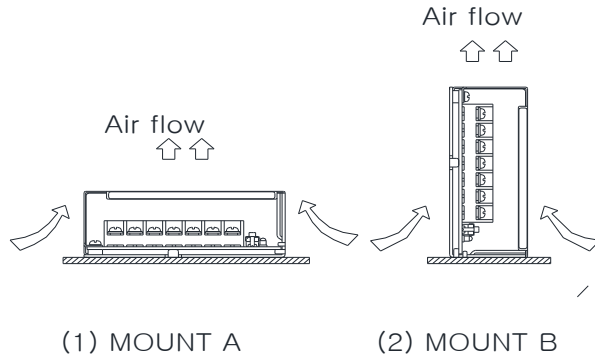

Fig 1.



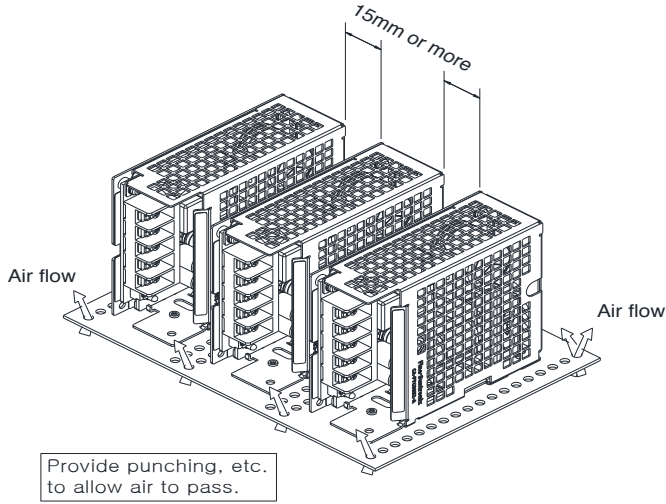

Fig 2. Applied installation

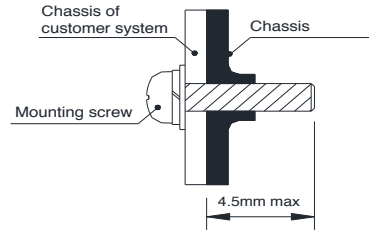
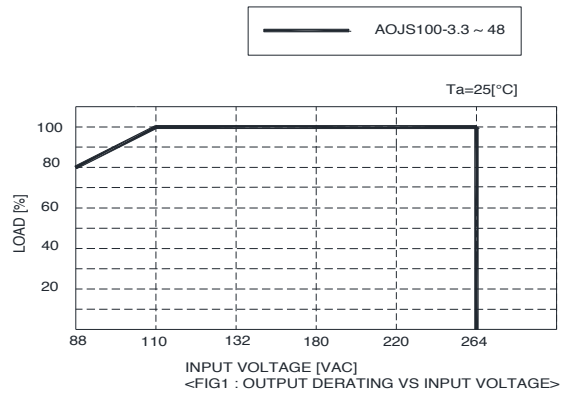

Fig 3. Screw limitation

6. Output derating curve

Output derating curve should be considered based on existence of top case and installation method.





ETA-USA

The Power Professionals

7. Caution

- o Please confirm if the capacity of the product is suitable for your intended use before putting it in use.
- o Only the rated input voltage specified on the product should be used.
- o Only the wires with rated capacity should be connected to this product, as allowable voltage and current is varied according to each type of wire.
- o Ground terminal of this product must be grounded before use to prevent electric shock or electromagnetic interference.
- o Be cautious to keep the product clean as foreign subject near input & output terminal or inside of the product could cause serious damages.
- o For the purpose of safety as well as reliability of the product, please avoid using the product at the following sites:
 - A place near water or fire
 - A place with high room temperature and poor ventilation
 - A place with a presence of foreign subject or dust
 - A place near volatile or flammable compounds
 - A place with high humidity
 - A place vulnerable for vibration or shock



ETA-USA

16170 Vineyard Blvd. Suite 180 Morgan Hill, CA 95037 <http://www.eta-usa.com>
Toll-free (US only): 800-ETA-POWR (800-382-7697) Telephone: 408 778-2793 FAX: 408-779-2753