



**Features**

- Single Power Supply 1.8V to 3.6V
- Very Low Current (see table for all modes)
- >5dBm 11g P<sub>OUT</sub>@<1% and 10dBm 11g P<sub>OUT</sub>@≤4%
- P<sub>OUT</sub>=19dBm Meeting Class 1 BT
- Gain: 28dB Typ 11b/g/BT

**Applications**

- IEEE802.11b/g/n Driver/Amplifier
- General Purpose Amplification
- Class 1 Bluetooth Power Amplifier
- Driver Amplifier for TX Power Amplifier

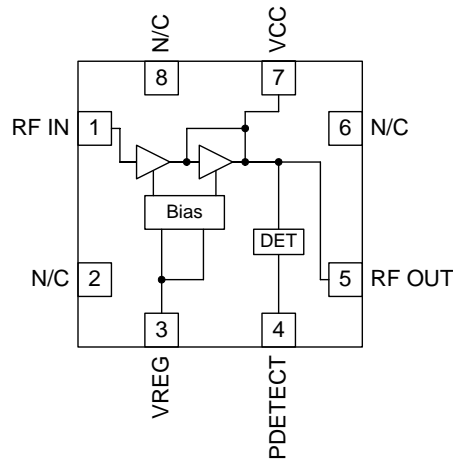

Functional Block Diagram

**Product Description**

The RF5373 is a linear driver/amplifier that meets the FCC and ETSI requirements for operation in the 2.4GHz to 2.5GHz (IEEE802.11b/g/n and BT Class 1) bands. Operating from a single 1.8V to 3.6V supply, the amplifier will easily be incorporated into WLAN designs with minimal external components. The device is manufactured on an advanced InGaP Gallium Arsenide Heterojunction Bipolar Transistor (HBT) process. The device is provided in a 2.2mmx2.2mmx0.6mm, 8-pin, QFN with a backside ground.

**Ordering Information**

RF5373	1.8V to 3.6V IEEE802.11b/g/n and Bluetooth Driver/Amplifier
RF5373PCBA-41X	Fully Assembled Evaluation Board
RF5373PCBA-410	IEEE802.11b/g 2.4GHz to 2.5GHz Operation

**Optimum Technology Matching® Applied**

- |   |                                      |                                     |                                   |
|---|--------------------------------------|-------------------------------------|-----------------------------------|
| <input type="checkbox"/> GaAs HBT             | <input type="checkbox"/> SiGe BiCMOS | <input type="checkbox"/> GaAs pHEMT | <input type="checkbox"/> GaN HEMT |
| <input type="checkbox"/> GaAs MESFET          | <input type="checkbox"/> Si BiCMOS   | <input type="checkbox"/> Si CMOS    |                                   |
| <input checked="" type="checkbox"/> InGaP HBT | <input type="checkbox"/> SiGe HBT    | <input type="checkbox"/> Si BJT     |                                   |

RF MICRO DEVICES®, RFMD®, Optimum Technology Matching®, Enabling Wireless Connectivity™, PowerStar®, POLARIS™ TOTAL RADIO™ and UltimateBlue™ are trademarks of RFMD, LLC. BLUETOOTH is a trademark owned by Bluetooth SIG, Inc., U.S.A. and licensed for use by RFMD. All other trade names, trademarks and registered trademarks are the property of their respective owners. ©2006, RF Micro Devices, Inc.

## Absolute Maximum Ratings

Parameter	Rating	Unit
Supply Voltage	-0.5 to +3.6	V
DC Supply Current	90	mA
RF - Input Power	15	dBm
Operating Temperature	-30 to +85	°C
Storage Temperature	-40 to +100	°C
Moisture Sensitivity	JEDEC Level 3	
ESD Human Body Model (EIA/JESD22-114-A)	600	V
ESD Machine Model (EIA/JESD22-115-A)	100	V



**Caution!** ESD sensitive device.

Exceeding any one or a combination of the Absolute Maximum Rating conditions may cause permanent damage to the device. Extended application of Absolute Maximum Rating conditions to the device may reduce device reliability. Specified typical performance or functional operation of the device under Absolute Maximum Rating conditions is not implied.

RoHS status based on EU Directive 2002/95/EC (at time of this document revision).

The information in this publication is believed to be accurate and reliable. However, no responsibility is assumed by RF Micro Devices, Inc. ("RFMD") for its use, nor for any infringement of patents, or other rights of third parties, resulting from its use. No license is granted by implication or otherwise under any patent or patent rights of RFMD. RFMD reserves the right to change component circuitry, recommended application circuitry and specifications at any time without prior notice.

Parameter	Specification			Unit	Condition
	Min.	Typ.	Max.		
<b>IEEE802.11b</b>					Nominal conditions: $V_{CC}=3.1V$ , $V_{REG}=1.75V$ , Freq = 2.45 GHz, Temp = +25 °C, unless otherwise specified.
Frequency	2.4		2.5	GHz	
Output Power		12	16	dBm	Meeting IEEE802.11b spectral mask requirements
Gain	25	28		dB	2.4GHz to 2.5GHz
Gain Variance Over Temperature -30 °C to +85 °C		1.0		±dB	2.4GHz to 2.5GHz
Second Harmonic			-27	dBm	Fundamental frequency is between 2400MHz to 2500MHz ( $RFP_{OUT}=+12dBm$ ), see note 2
802.11b Adjacent Channel Power		-38	-32	dBc	$P_{OUT}=12dBm$ at nominal conditions
Alternate Channel Power		-56	-52	dBc	$P_{OUT}=12dBm$ at nominal conditions
IEEE802.11b Spectral Mask per FCC Part 15.205			-43	dBm	Amplifier setup for best IEEE802.11g performance; FC=2412MHz; $RFP_{OUT}=+12dBm$ ; IEEE802.11b CCK 11Mbps modulation; T = +25 °C; measured at FC-25 MHz
			-43	dBm	Amplifier setup for best IEEE802.11g performance; FC=2462MHz; $RFP_{OUT}=+12dBm$ ; IEEE802.11b CCK 11Mbps modulation; T = +25 °C; measured at FC+25 MHz
Operating Current		50		mA	$P_{OUT}=12dBm$ at nominal conditions
Idle Current		45		mA	At nominal conditions with no RF
$I_{REG}$ Current		5.5	6.5	mA	
Shutdown Current			10	µA	
Power Detector					
$P_{OUT}=+10dBm$	0.5	0.6	0.7	V	
$P_{OUT}=+12dBm$	0.52	0.65	0.75	V	
Input Capacitance		5		pF	
Bandwidth		8		MHz	

Parameter	Specification			Unit	Condition
	Min.	Typ.	Max.		
<b>IEEE802.11g</b>					Nominal conditions: $V_{CC}=3.1V$ , $V_{REG}=1.75V$ pulsed at 1% to 100% duty cycle, Freq=2.45GHz, Temp=+25°C, unless otherwise specified.
Frequency	2.4		2.5	GHz	
Output Power		10	12	dBm	2.4GHz to 2.5GHz
EVM			4	%	
Gain	25	28		dB	2.4GHz to 2.5GHz
Gain Variance Over Temperature -30°C to +85°C		1.0		±dB	2.4GHz to 2.5GHz
Second Harmonic			-27	dBm	Fundamental frequency is between 2400MHz to 2500MHz ( $RFP_{OUT}=+10dBm$ ), see note 2
IEEE802.11g Spectral Mask per FCC Part 15.205			-43	dBm	Amplifier setup for best IEEE802.11g performance; FC=2412MHz; $RFP_{OUT}=+10dBm$ ; IEEE802.11b CCK 11Mbps modulation; T=+25°C; measured at FC-25MHz
			-43	dBm	Amplifier setup for best IEEE802.11g performance; FC=2462MHz; $RFP_{OUT}=+10dBm$ ; IEEE802.11b CCK 11Mbps modulation; T=+25°C; measured at FC+25MHz
Operating Current		50		mA	$P_{OUT}=+10dBm$ at nominal conditions
Idle Current		45		mA	At nominal conditions with no RF
$I_{REG}$ Current		5.5		mA	
Shutdown Current			10	µA	
Power Detector					
$P_{OUT}=+10dBm$	0.40	0.55	0.7	V	
Input Capacitance		5		pF	
Bandwidth		8		MHz	
Turn-On Time		1.5	1.8	µS	Output stable to within 90% of final gain, see note 1.

Parameter	Specification			Unit	Condition
	Min.	Typ.	Max.		
<b>Bluetooth Class 1</b>					Nominal conditions: $V_{CC}=3.1V$ , $V_{REG}=1.75V$ , Freq=2.45GHz, Temp=+25°C, unless otherwise specified.
Frequency	2.4		2.5	GHz	
Output Power BT version 1.2		19		dBm	Meeting Class 1 Bluetooth version 1.2 specification
Output Power BT version 2.0		16			Meeting Class 1 Bluetooth version 2.0 specification
Large Signal Gain	25	28		dB	Measured at rated output power; nominal conditions
Second Harmonic			-27	dBm	Fundamental frequency is between 2400MHz to 2500MHz ( $RF P_{OUT}=+16dBm$ ), see note 2
Operating Current		65		mA	$P_{OUT}=16dBm$ at nominal conditions
Idle Current		45		mA	At nominal conditions with no RF
$I_{REG}$ Current		5.5		mA	
Shutdown Current			10	$\mu A$	
<b>Power Supply</b>					
$V_{CC}$ Supply Voltage	1.8	3.1	3.6	V	
$V_{REG}$ Voltage	1.6	1.75	1.85	V	

Note 1: The PA must operate with gated bias at 1% to 99% duty cycles without any EVM or other parameter degradation with  $R1=56\Omega$ .

Note 2: For best harmonic rejection please refer to the harmonic rejection application schematic.

Pin	Function	Description	Interface Schematic
1	RF IN	RF input pin. See evaluation board schematic for details.	
2	N/C	No Connect, this pin may be left as a no connect or connected to ground.	
3	VREG	Bias current control voltage for the first and second stages.	
4	PDETECT or NC*	Provides an output voltage proportional to the output RF level. *In applications where the P <sub>DETECT</sub> is not desired, this pin may be left unconnected.	
5	RF OUT	RF output.	
6	N/C	No Connect, this pin may be left as a no connect or connected to ground.	
7	VCC	Power supply for both the first and second stage. Connect as shown on the evaluation board schematic.	
8	N/C	No Connect, this pin may be left as a no connect or connected to ground.	
Pkg Gnd	GND	Ground connection for the device "die flag". The backside of the package should be soldered to a top side ground pad which is connected to the PC board ground plane through multiple vias.	

**Package Drawing**

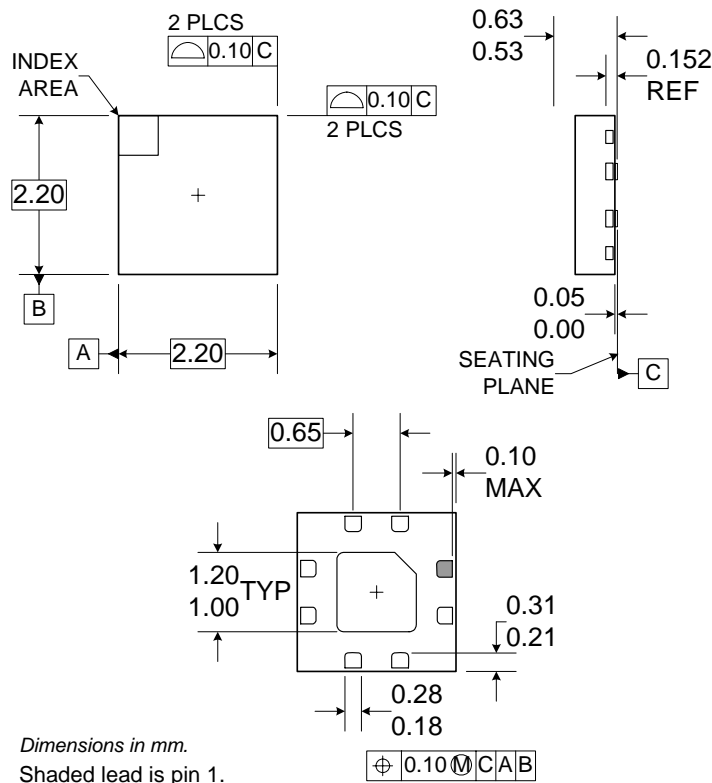

## Theory of Operation

The RF5373 is a linear driver/amplifier that is designed for the 2.4GHz to 2.5GHz (IEEE802.11b/g and BT Class 1) band. Operating from a single 1.8V to 3.6V supply, the amplifier will easily be incorporated into WLAN designs with minimal external components. The device is provided in a 2.2mmx2.2mmx0.6mm, 8-pin, QFN with a backside ground.

The RF5373 is a two-stage device with a nominal gain of 28dB to 29dB in the 2.4GHz to 2.5GHz ISM band. The RF5373 is designed for multiple applications in the 2.4GHz to 2.5GHz band. The RF5373 requires only a single positive supply of 1.8V to 3.6V to operate to full specification. Power control is provided through one bias control input pin ( $V_{REG}$ ) which can range from 1.6V nominal and 1.85V maximum. The PA circuit layout from the evaluation board should be copied as closely as possible, particularly the ground layout and ground vias. Other configurations may also work, but the design process is much easier and quicker if the layout is copied from the RF5373 evaluation board. Gerber files of our designs are available on request.

There are multiple applications where the RF5373 may be implemented, including IEEE802.11b/g and Bluetooth. Please review the RF5373 schematics for the optimum layout for a specific band. In order to obtain the best performance for an 802.11g application where the PA will be pulsed at <99% duty cycle, R1 must be populated with a 56 $\Omega$  resistor. For all other applications where pulsing is not needed, R1 can be substituted with a 0 $\Omega$  or a trace line.

An application schematic for 2.5GHz operation is included that has two additional components, one shunt inductor, and one shunt capacitor, on the output for improved second harmonic rejection. This layout provides ~20dB rejection at 5GHz with a minimal BOM count.

The RF5373 is not a difficult part to implement, but care in circuit layout and component selection is always advisable when designing circuits to operate at 2.5GHz. The RF5373 evaluation board layout and schematic is also available using 0201 components which will help shrink the size of the total area of the power amplifier and matching components on the intended design.

Please contact RFMD Sales or Applications Engineering for additional data and guidance.

## Pin Out

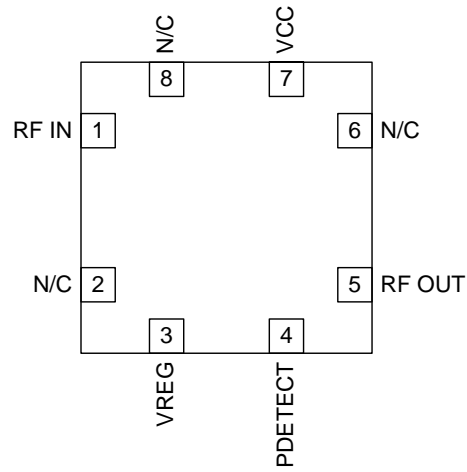

## Application Schematic IEEE802.11b/g and Bluetooth Class Low Band Application Schematic for Harmonics Rejection

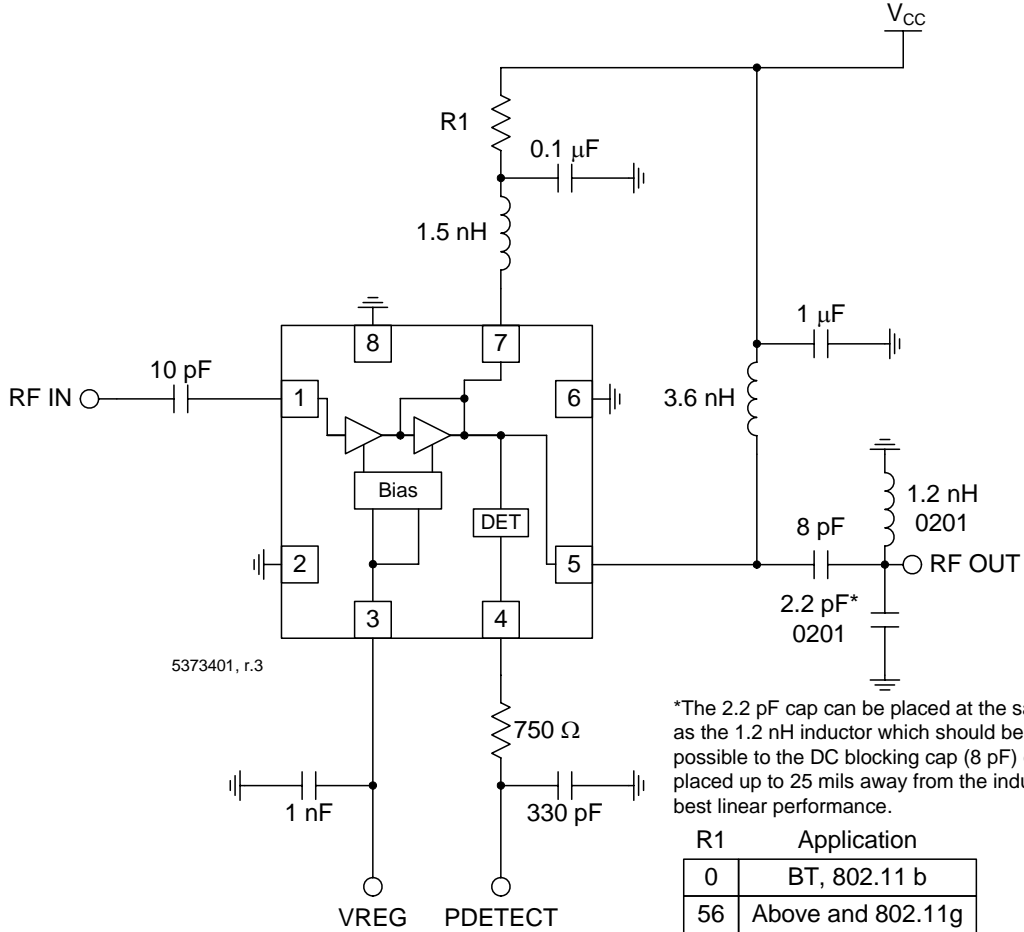

**NOTES:**

1. For VREG that is higher than the nominal voltage specified, a resistor bridge can be used to drop the voltage for VREG to the appropriate level needed at the pins.
2. This evaluation board schematic and layout are also available using 0201 components. Please contact RFMD applications engineering for more information.



**Evaluation Board Schematic  
IEEE802.11b/g and Bluetooth Class 1,  
High Pass Output Match Tune**

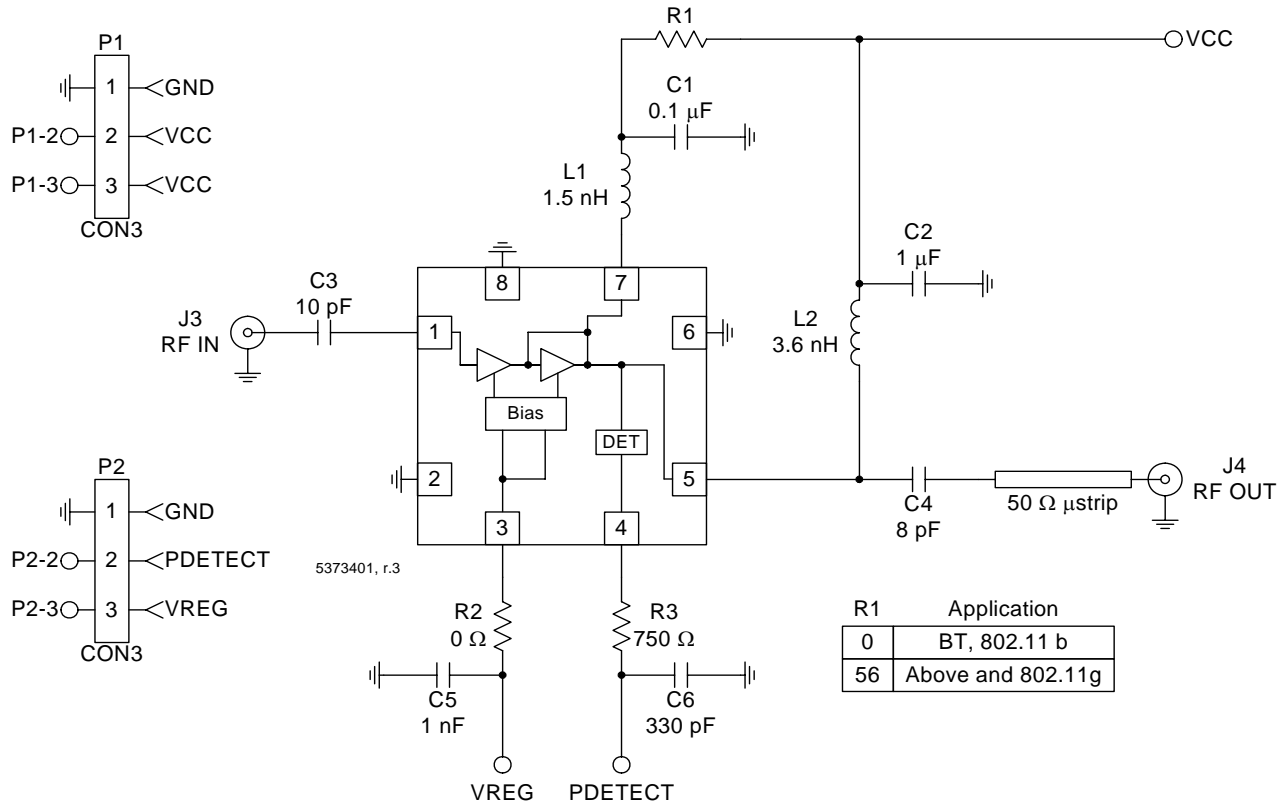

**NOTES:**

1. For VREG that is higher than the nominal voltage specified, a resistor bridge can be used to drop the voltage for VREG to the appropriate level needed at the pins.
2. This evaluation board schematic and layout are also available using 0201 components. Please contact RFMD applications engineering for more information.

## Evaluation Board Layout Board Size 1.2" x 1.2" Board Thickness 0.032", Board Material FR-4

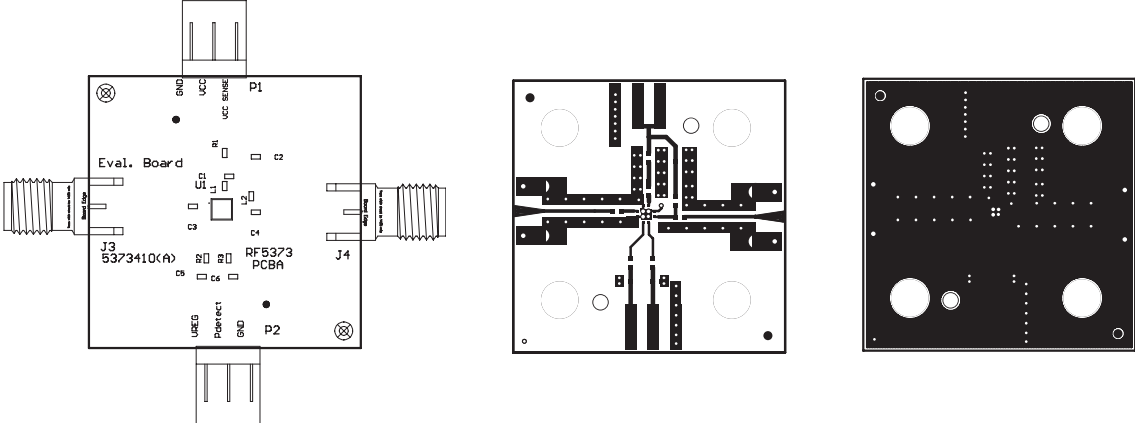

ACP versus P<sub>OUT</sub>

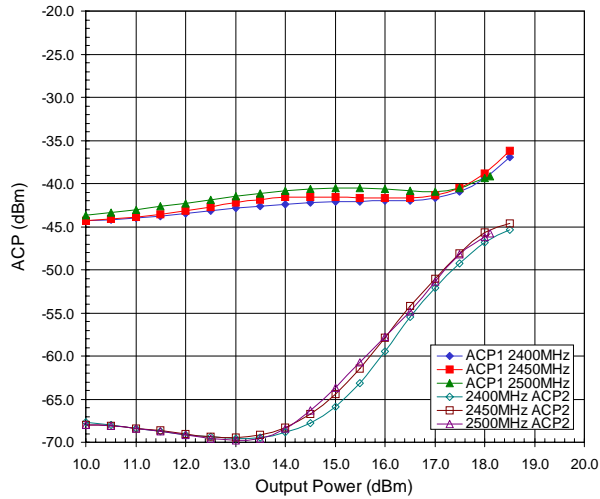

EVM versus P<sub>OUT</sub>

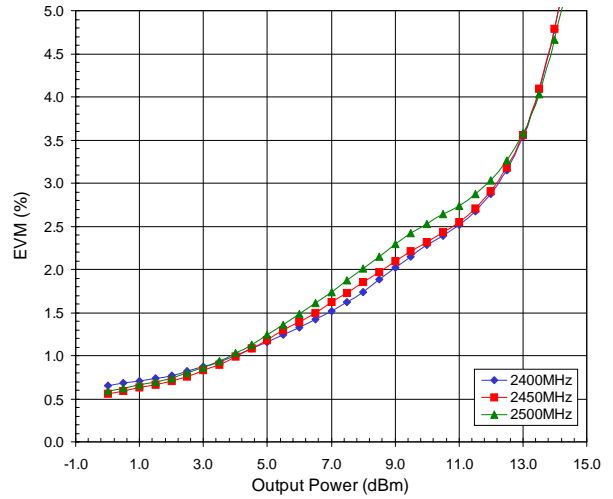

Operating Current versus P<sub>OUT</sub>

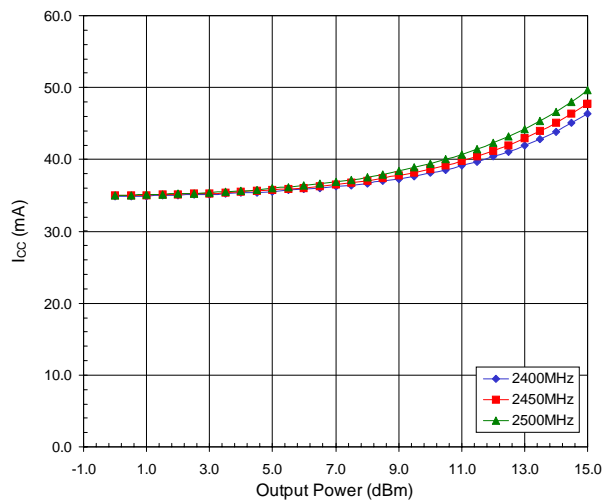

P<sub>DETECT</sub> versus P<sub>OUT</sub>

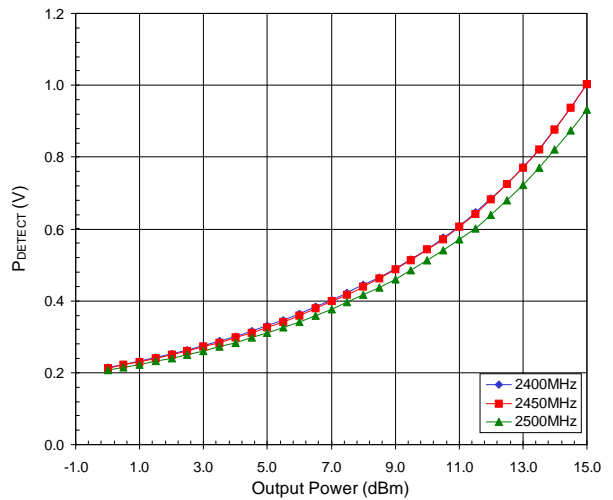

## PCB Design Requirements

### PCB Surface Finish

The PCB surface finish used for RFMD's qualification process is electroless nickel, immersion gold. Typical thickness is 3µinch to 8µinch gold over 180µinch nickel.

### PCB Land Pattern Recommendation

PCB land patterns are based on IPC-SM-782 standards when possible. The pad pattern shown has been developed and tested for optimized assembly at RFMD; however, it may require some modifications to address company specific assembly processes. The PCB land pattern has been developed to accommodate lead and package tolerances.

### PCB Metal Land Pattern

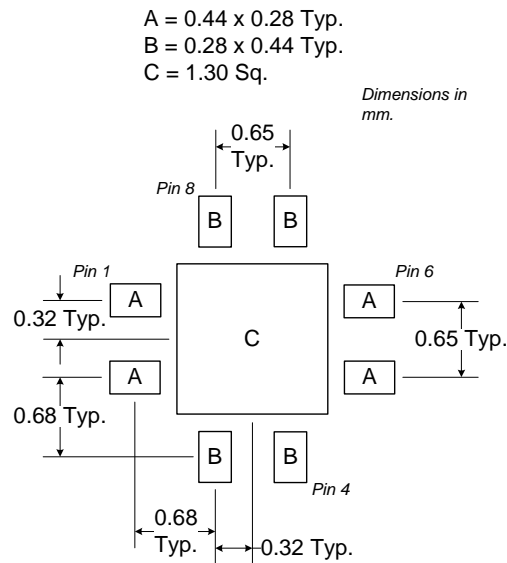

### PCB Solder Mask Pattern

Liquid Photo-Imageable (LPI) solder mask is recommended. The solder mask footprint will match what is shown for the PCB metal land pattern with a 2mil to 3mil expansion to accommodate solder mask registration clearance around all pads. The center-grounding pad shall also have a solder mask clearance. Expansion of the pads to create solder mask clearance can be provided in the master data or requested from the PCB fabrication supplier.

A = 0.57 x 0.41 Typ.  
 B = 0.41 x 0.57 Typ.  
 C = 1.20 Sq.

*Dimensions in mm.*

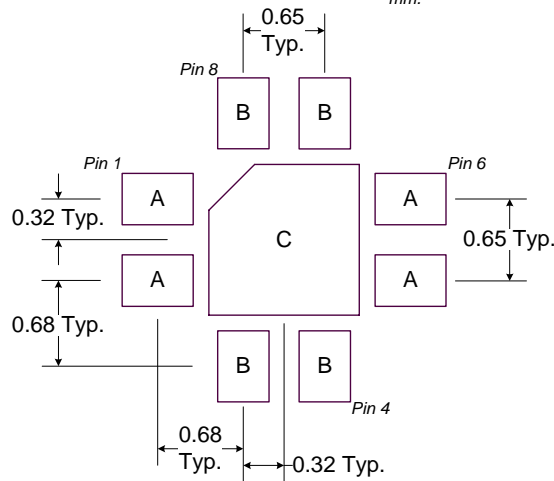

## RoHS\* Banned Material Content

RoHS Compliant: Yes  
 Package total weight in grams (g): 0.008  
 Compliance Date Code: N/A  
 Bill of Materials Revision: A  
 Pb Free Category: e3

Bill of Materials	Parts Per Million (PPM)					
	Pb	Cd	Hg	Cr VI	PBB	PBDE
Die	0	0	0	0	0	0
Molding Compound	0	0	0	0	0	0
Lead Frame	0	0	0	0	0	0
Die Attach Epoxy	0	0	0	0	0	0
Wire	0	0	0	0	0	0
Solder Plating	0	0	0	0	0	0

**This RoHS banned material content declaration was prepared solely on information, including analytical data, provided to RFMD by its suppliers, and applies to the Bill of Materials (BOM) revision noted**

\* DIRECTIVE 2002/95/EC OF THE EUROPEAN PARLIAMENT AND OF THE COUNCIL of 27 January 2003 on the restriction of the use of certain hazardous substances in electrical and electronic equipment