

DESCRIPTION

The MPQ18021A is a high-frequency, 100V, half-bridge, N-channel power MOSFET driver. Its low-side and high-side driver channels are independently controlled and matched with a time delay of less than 5ns. Under-voltage lockout on both high-side and low-side supplies force their outputs low in case of insufficient supply. The integrated bootstrap diode reduces external component count.

FEATURES

- Drives N-Channel MOSFET Half Bridge
- 115V V_{BST} Voltage Range
- On-Chip Bootstrap Diode
- Typical 16ns Propagation Delay Time
- Less Than 5ns Gate Drive Matching
- Drives 1nF Load with 12ns/9ns Rise/Fall Times with 12V VDD
- TTL Compatible Input
- Less Than 150 μ A Quiescent Current
- UVLO for Both High-Side and Low-Side
- In SOIC8 Package

APPLICATIONS

- Telecom Half-Bridge Power Supplies
- Avionics DC-DC Converters
- Two-Switch Forward Converters
- Active Clamp Forward Converters

All MPS parts are lead-free and adhere to the RoHS directive. For MPS green status, please visit MPS website under Products, Quality Assurance page. "MPS" and "The Future of Analog IC Technology" are registered trademarks of Monolithic Power Systems, Inc.

TYPICAL APPLICATION

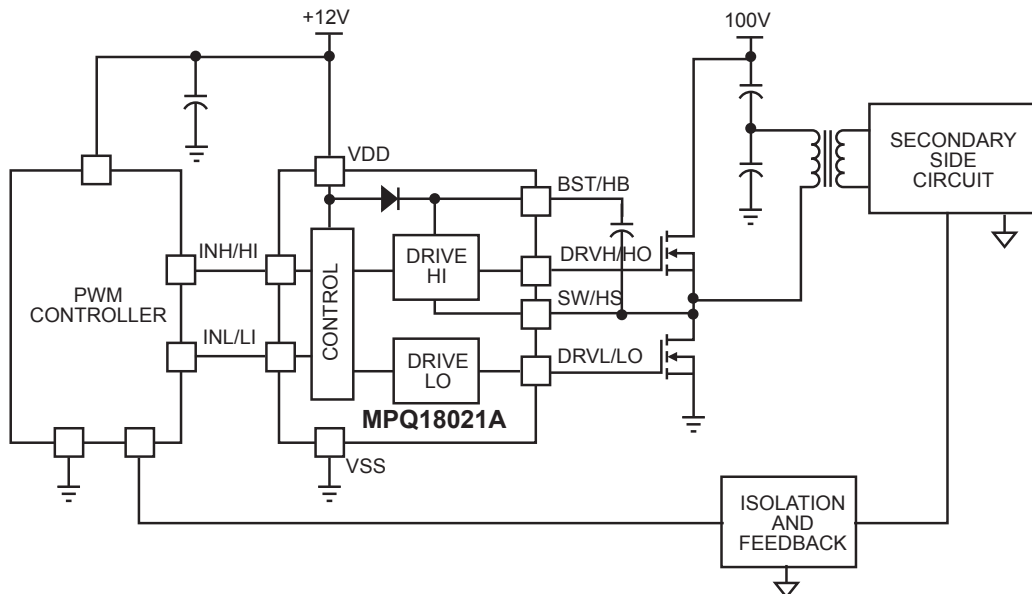

ORDERING INFORMATION

Part Number	Package	Top Marking
MPQ18021HS-A*	SOIC8	MP18021A

* For Tape & Reel, add suffix -Z (e.g. MPQ18021HS-A-Z);
 For RoHS compliant packaging, add suffix -LF (e.g. MPQ18021HS-A-LF-Z)

PACKAGE REFERENCE

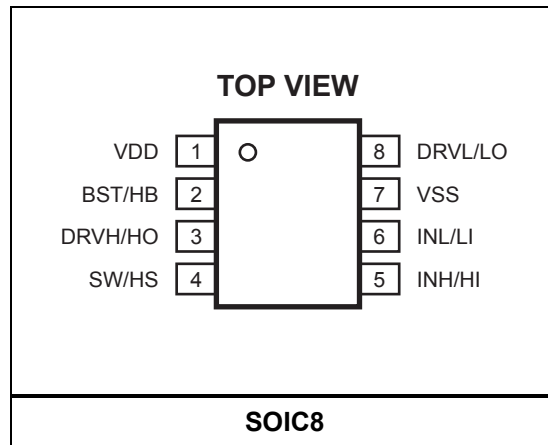

Absolute Maximum Ratings ⁽¹⁾

Supply Voltage (VDD).....	-0.3V to +20V
SW Voltage (V _{SW})	-5.0V to +105V
BST Voltage (V _{BST})	-0.3V to +120V
BST to SW	-0.3V to +18V
DRVH to SW	-0.3V to (BST-SW) + 0.3V
DRVL to VSS	-0.3V to (VDD + 0.3V)
All Other Pins.....	-0.3V to (VDD + 0.3V)
Continuous Power Dissipation (T _A =25°C) ⁽²⁾	
SOIC8.....	1.4W
Junction Temperature	150°C
Lead Temperature	260°C
Storage Temperature.....	-65°C to +150°C

Recommended Operating Conditions ⁽³⁾

Supply Voltage (V _{DD}).....	9.0V to 18V
SW Voltage (V _{SW})	-1.0V to +100V
SW slew rate	<50V/ns
Operating Junction Temp. (T _J)	-40°C to +125°C

Thermal Resistance ⁽⁴⁾	θ_{JA}	θ_{JC}
SOIC8	90	45... °C/W

Notes:

- Exceeding these ratings may damage the device.
- The maximum allowable power dissipation is a function of the maximum junction temperature T_J(MAX), the junction-to-ambient thermal resistance θ_{JA}, and the ambient temperature T_A. The maximum allowable continuous power dissipation at any ambient temperature is calculated by P_D(MAX)=(T_J(MAX)-T_A)/ θ_{JA}. Exceeding the maximum allowable power dissipation will cause excessive die temperature, and the regulator will go into thermal shutdown. Internal thermal shutdown circuitry protects the device from permanent damage.
- The device is not guaranteed to function outside of its operating conditions.
- Measured on JESD51-7, 4-layer PCB.

ELECTRICAL CHARACTERISTICS

VDD = V_{BST}-V_{SW}=12V, VSS=V_{SW} = 0V, No load at DRVH and DRVL, T_J= -40°C to +125°C, Typical Value are T_J=25°C, unless otherwise noted.

Parameter	Symbol	Condition	Min	Typ	Max	Units
Supply Currents						
VDD quiescent current	I _{DDQ}	INL=INH=0		100	150	μA
VDD operating current	I _{DDO}	f _{sw} =500kHz		2.8	3.5	mA
Floating driver quiescent current	I _{BSTQ}	INL=INH=0		60	90	μA
Floating driver operating current	I _{BSTO}	f _{sw} =500kHz		2.1	3	mA
Leakage Current	I _{LK}	BST=SW=100V		0.05	1	μA
Inputs						
INL/INH High				2	2.4	V
INL/INH Low			1	1.4		V
INL/INH internal pull-down resistance	R _{IN}			185		kΩ
Under Voltage Protection						
VDD rising threshold	V _{DDR}		7.4	8.1	8.9	V
VDD hysteresis	V _{DDH}			0.5		V
(BST-SW) rising threshold	V _{BSTR}		6.5	7.1	7.7	V
(BST-SW) hysteresis	V _{BSTH}			0.55		V
Bootstrap Diode						
Bootstrap diode VF @ 100uA	V _{F1}			0.5		V
Bootstrap diode VF @ 100mA	V _{F2}			0.9		V
Bootstrap diode dynamic R	R _D	@ 100mA		2.5		Ω
Low Side Gate Driver						
Low level output voltage	V _{OLL}	I _O =100mA		0.15	0.32	V
High level output voltage to rail	V _{OHL}	I _O =-100mA		0.45	1	V
Peak pull-up current	I _{OHL}	V _{DRVL} =0V, V _{DD} =12V		1.5		A
		V _{DRVL} =0V, V _{DD} =16V		2.5		A
Peak pull-down current	I _{OLL}	V _{DRVL} =V _{DD} =12V		2.5		A
		V _{DRVL} =V _{DD} =16V		3.5		A
Floating Gate Driver						
Low level output voltage	V _{OLH}	I _O =100mA		0.15	0.32	V
High level output voltage to rail	V _{OHH}	I _O =-100mA		0.45	1	V
Peak pull-up current	I _{OHH}	V _{DRVH} =0V, V _{DD} =12V		1.5		A
		V _{DRVH} =0V, V _{DD} =16V		2.5		A
Peak pull-down current	I _{OLH}	V _{DRVH} =V _{DD} =12V		2.5		A
		V _{DRVH} =V _{DD} =16V		3.5		A

ELECTRICAL CHARACTERISTICS *(continued)*

VDD = V_{BST}-V_{SW}=12V, VSS=V_{SW} = 0V, No load at DRVH and DRVL, T_J= -40°C to +125°C, Typical Value are T_J=25°C, unless otherwise noted.

Parameter	Symbol	Condition	Min	Typ	Max	Units
Switching Spec. --- Low Side Gate Driver						
Turn-off propagation delay INL falling to DRVL falling	T _{DLFF}			16		ns
Turn-on propagation delay INL rising to DRVL rising	T _{DLRR}			16		
DRVL rise time		C _L =1nF		12		ns
DRVL fall time		C _L =1nF		9		ns
Switching Spec. --- Floating Gate Driver						
Turn-off propagation delay INL falling to DRVH falling	T _{DHFF}			16		ns
Turn-on propagation delay INL rising to DRVH rising	T _{DHRR}			16		ns
DRVH rise time		C _L =1nF		12		ns
DRVH fall time		C _L =1nF		9		ns
Switching Spec. --- Matching						
Floating driver turn-off to low side driver turn-on	T _{MON}			1	5	ns
Low side driver turn-off to floating driver turn-on	T _{MOFF}			1	5	ns
Minimum input pulse width that changes the output	T _{PW}				50 ⁽⁵⁾	ns
Bootstrap diode turn-on or turn- off time	T _{BS}			10 ⁽⁵⁾		ns

Note:

5) Guaranteed by design.

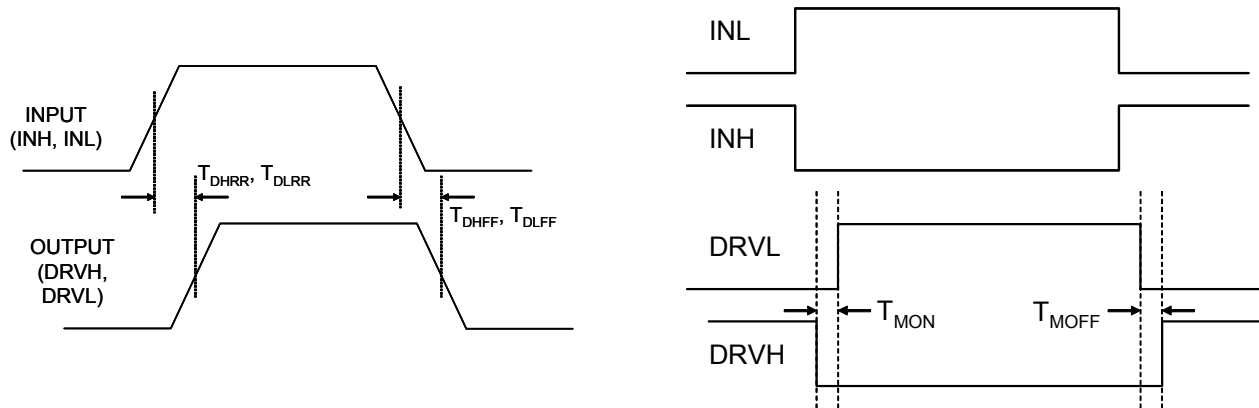
Figure 1: Timing Diagram

PIN FUNCTIONS

Pin #	Name	Description
1	VDD	Supply input. Supplies power to all the internal circuitry. Requires a decoupling capacitor to ground placed close to this pin to ensure stable and clean supply.
2	BST/HB	Bootstrap. Positive power supply for the internal floating high-side MOSFET driver. Connect a bypass capacitor between this pin and SW pin.
3	DRVH/HO	Floating driver output.
4	SW/HS	Switching node.
5	INH/HI	Control signal input for the floating driver.
6	INL/LI	Control signal input for the low side driver.
7	VSS	Chip ground.
8	DRVL/LO	Low side driver output.

TYPICAL PERFORMANCE CHARACTERISTICS

V_{DD} = 12V, V_{SS} = V_{SW} = 0V, T_A = 25°C, unless otherwise noted.

I_{DDO} Operation Current vs. Frequency

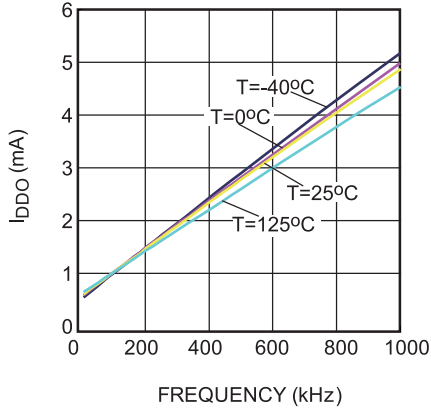

I_{BSTO} Operation Current vs. Frequency

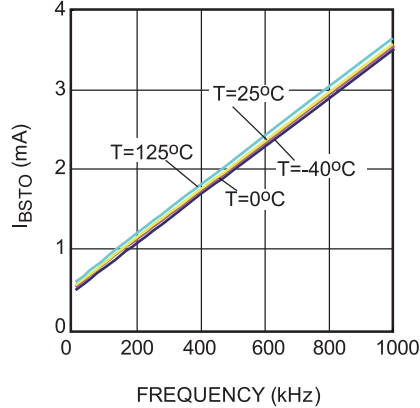

High Level Output Voltage vs. Temperature

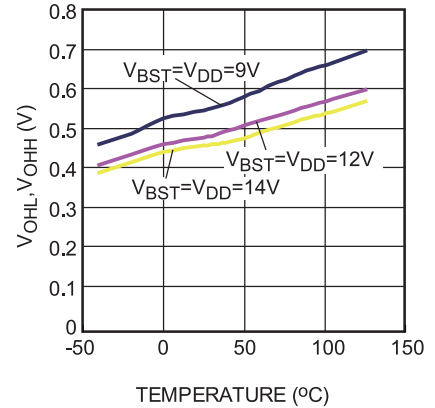

Low Level Output Voltage vs. Temperature

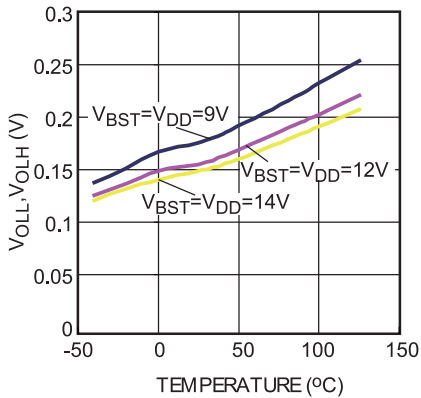

Undervoltage Lockout Threshold vs. Temperature

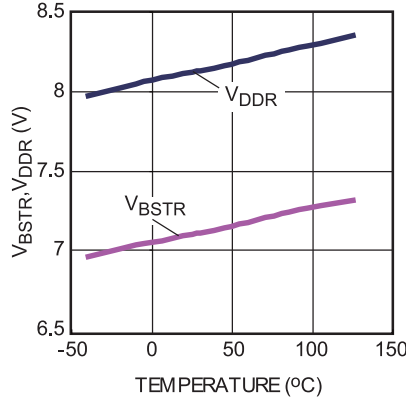

Undervoltage Lockout Hysteresis vs. Temperature

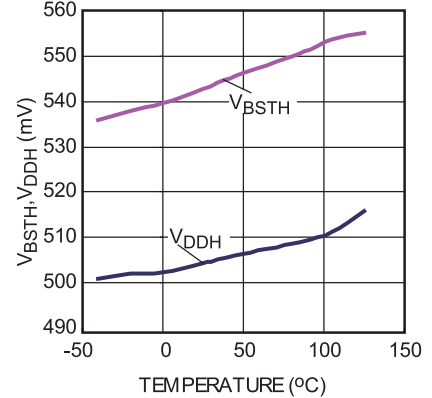

Propagation Delay vs. Temperature

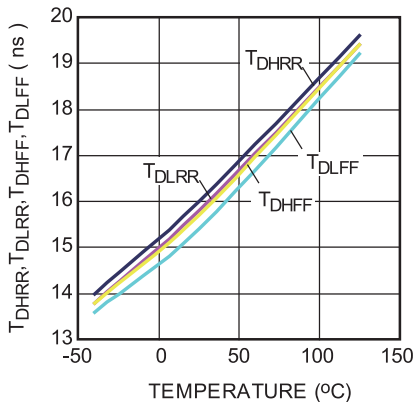

Bootstrap Diode I-V Characteristics

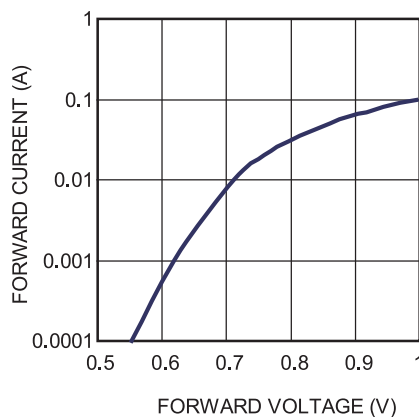

Quiescent Current vs. Voltage

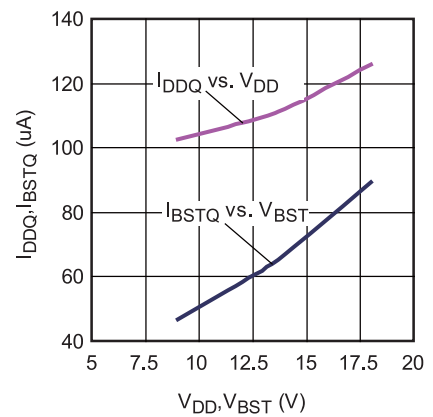

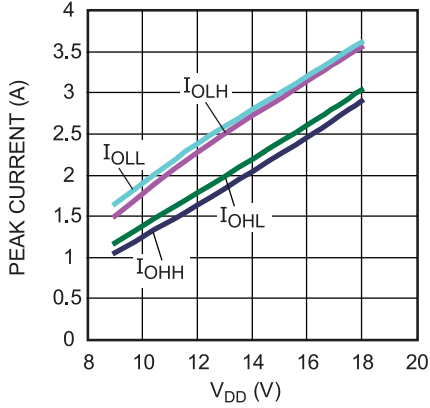
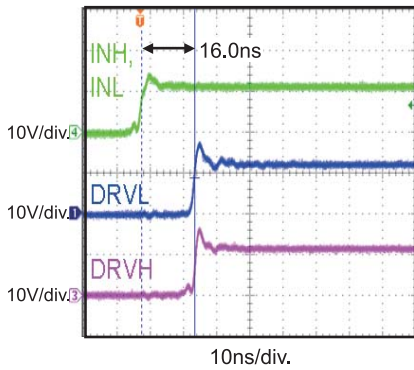
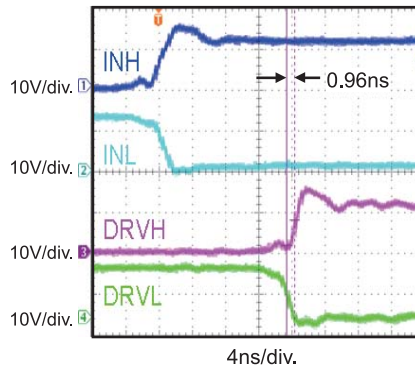
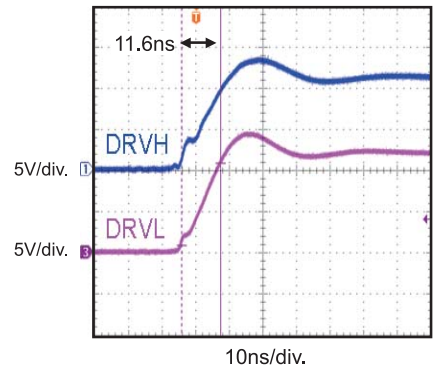
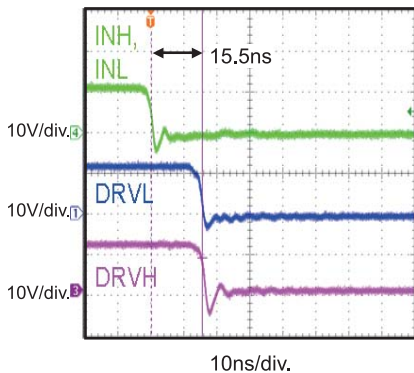
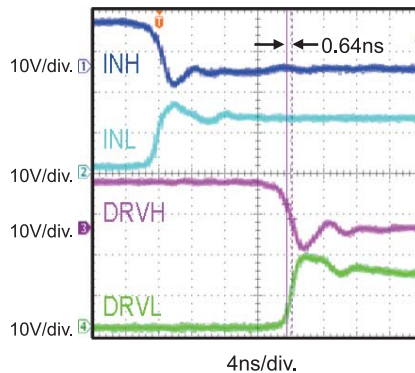
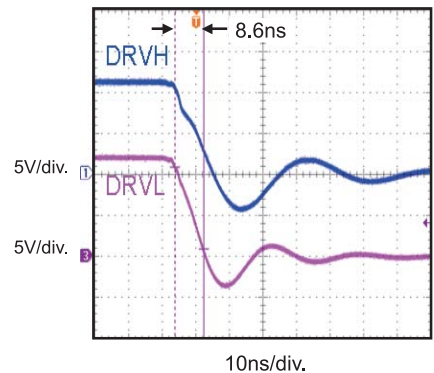
TYPICAL PERFORMANCE CHARACTERISTICS (continued)
V_{DD} = 12V, V_{SS} = V_{SW} = 0V, T_A = 25°C, unless otherwise noted.
Peak Current vs. V_{DD} Voltage

Turn-on Propagation Delay

Gate Drive Matching T_{MOFF}

Drive Rise Time (1nF Load)

Turn-off Propagation Delay

Gate Drive Matching T_{MON}

Drive Fall Time (1nF Load)

BLOCK DIAGRAM

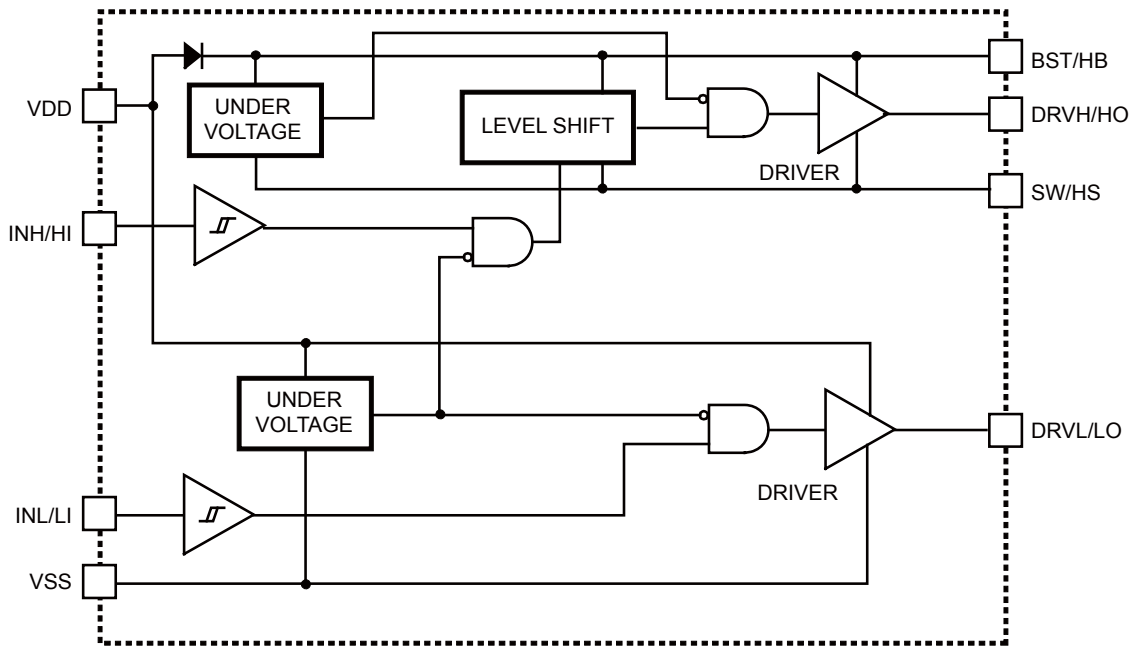

Figure 2: Functional Block Diagram

APPLICATION

The INH and INL input signals can be controlled independently. If both INH and INL control the HSFET and LSFET of the same bridge, then users must avoid shoot through by a setting

sufficient dead time between INH low and INL high, and vice versa, as per **Figure 3** below. Dead time is defined as the time interval when both INH and INL are low.

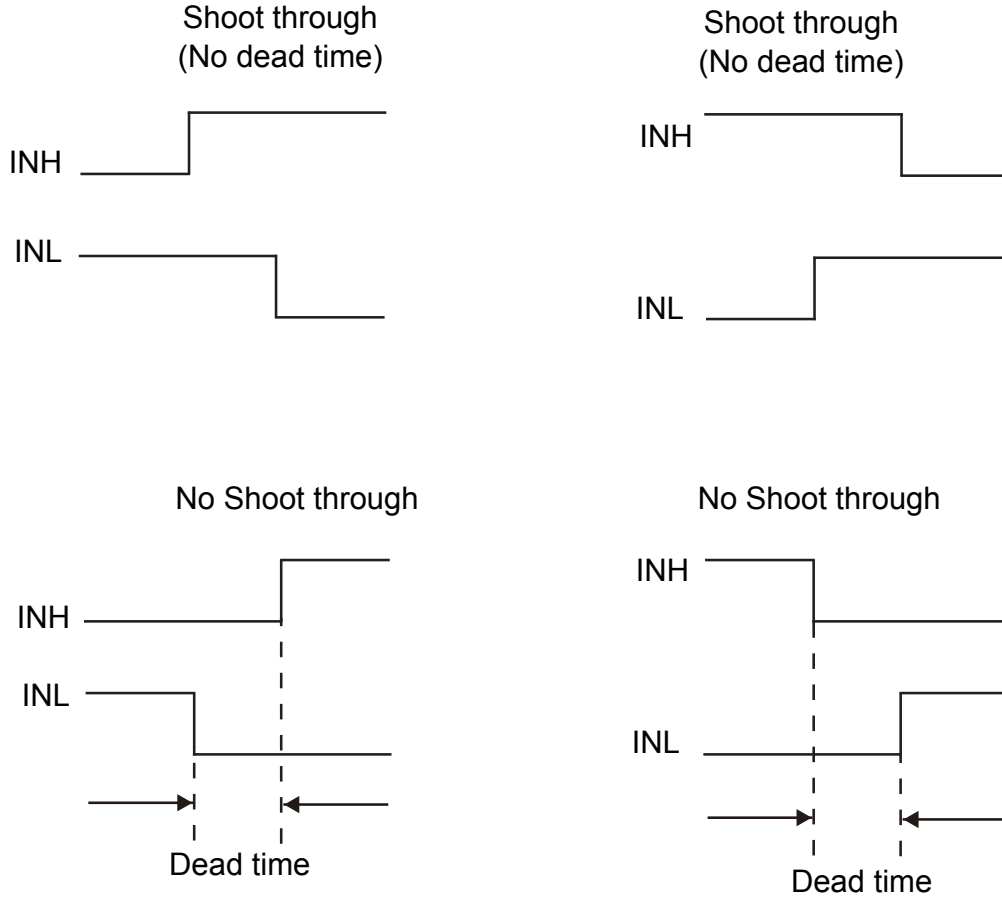

Figure 3: INH and INL Dead Time

REFERENCE DESIGN CIRCUITS

Half-Bridge Converter

In half-bridge converter topology, the MOSFETs are alternately driven with some dead time between signals. Therefore, INH and INL are

driven with alternating signals from the PWM controller. The input voltage can go up to 100V in this application.

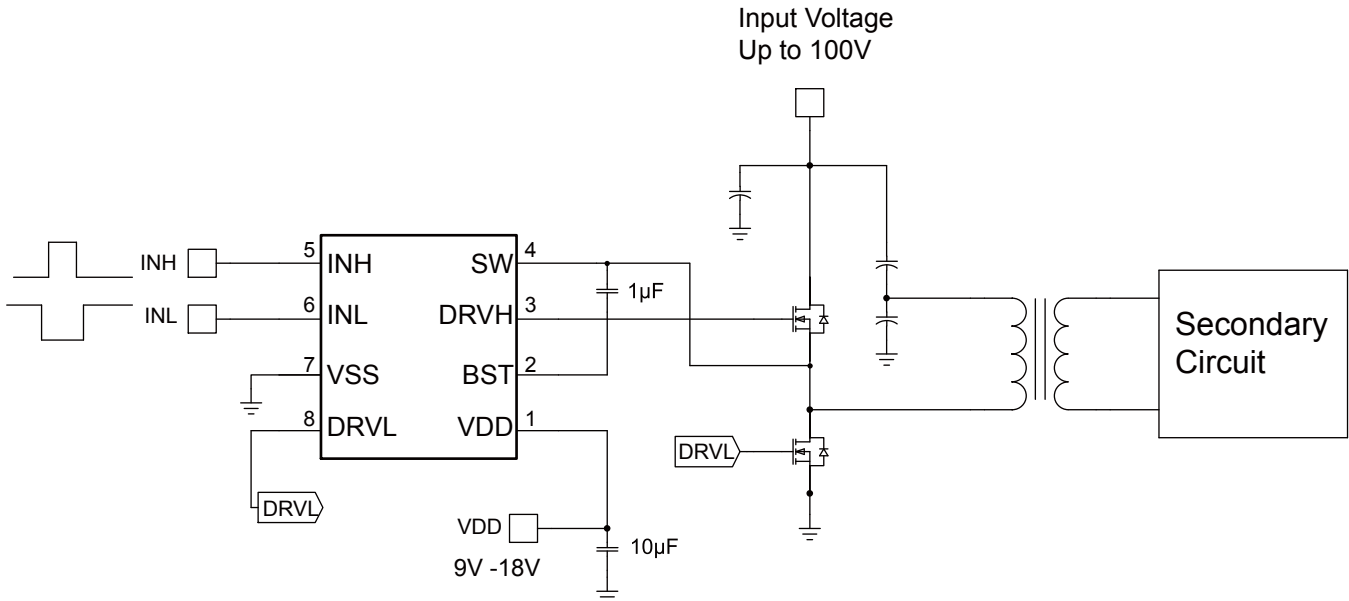

Figure 4: Half-Bridge Converter

Two-Switch Forward Converter

In two-switch forward converter topology, both MOSFETs turn on and off together. The input signals (INH and INL) come from the PWM controller, which senses the output voltage (and output current if current-mode control is used).

The Schottky diodes clamp the reverse swing of the power transformer and must be rated at the input voltage. The input voltage can go up to 100V in this circuit.

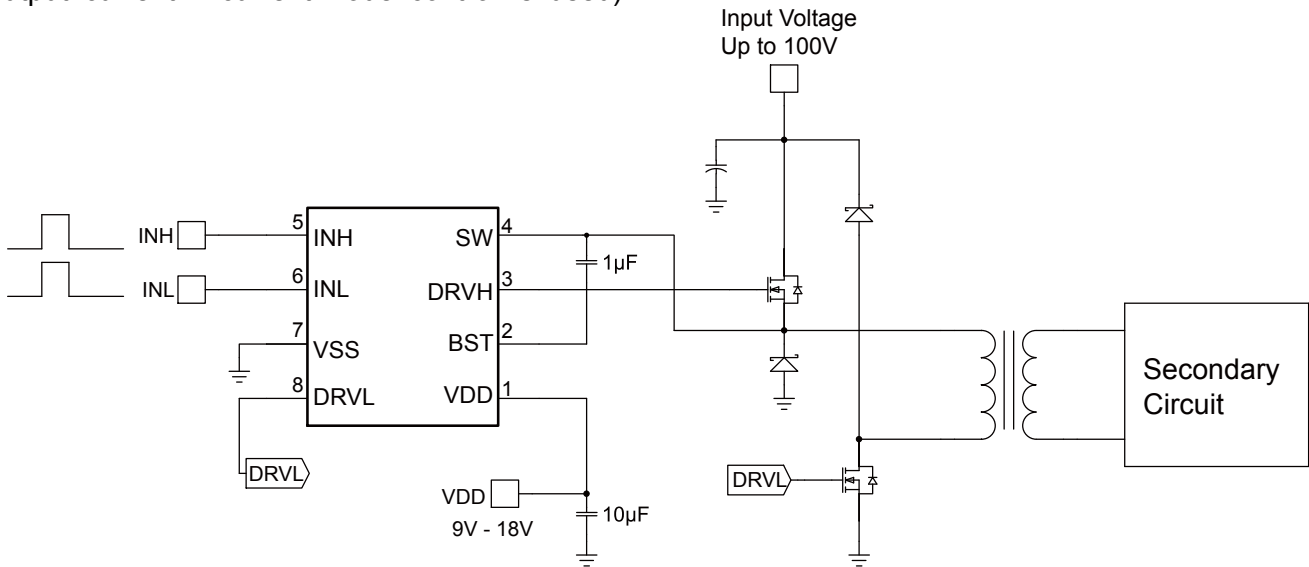

Figure 5: Two-Switch Forward Converter

Active-Clamp Forward Converter

In active-clamp forward converter topology, the MOSFETs are driven alternately. The high-side MOSFET and the capacitor C_{reset} losslessly reset the power transformer.

This topology lends itself well to run at duty cycles exceeding 50%. Therefore, the input voltage for this application may not be able to go to 100V.

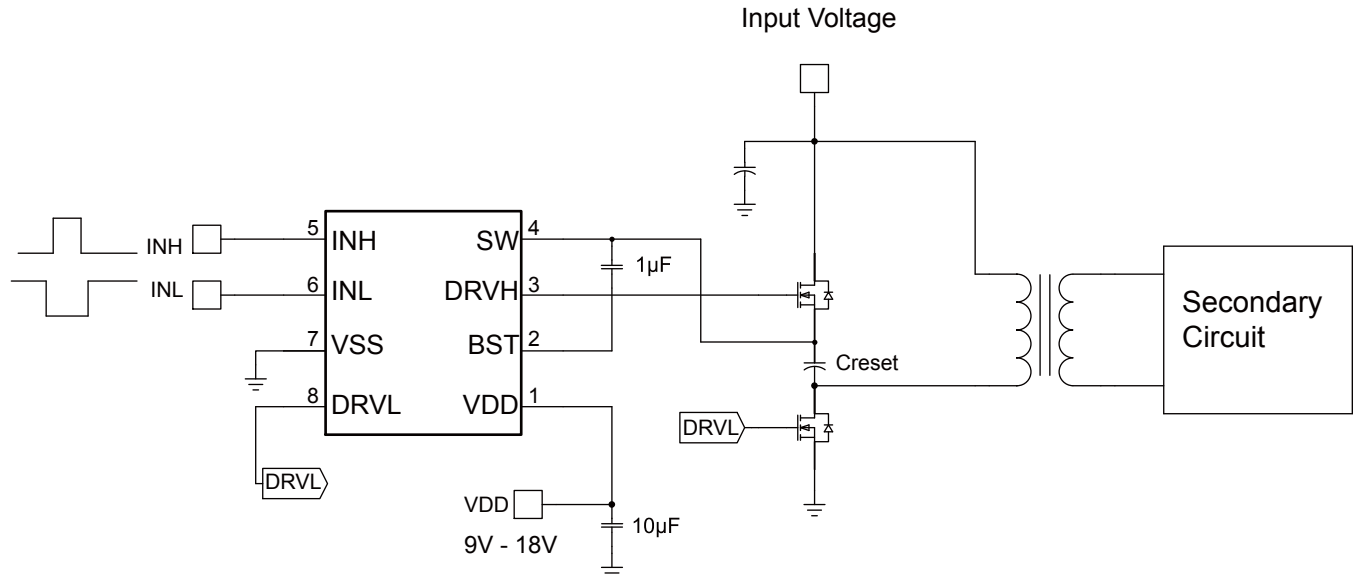
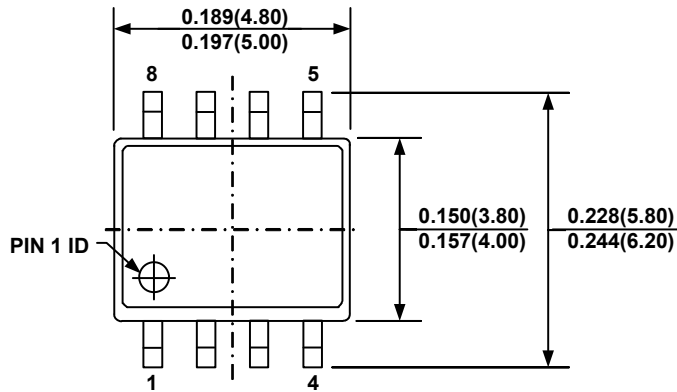

Figure 6: Active-Clamp Forward Converter

PACKAGE INFORMATION

SOIC8



TOP VIEW

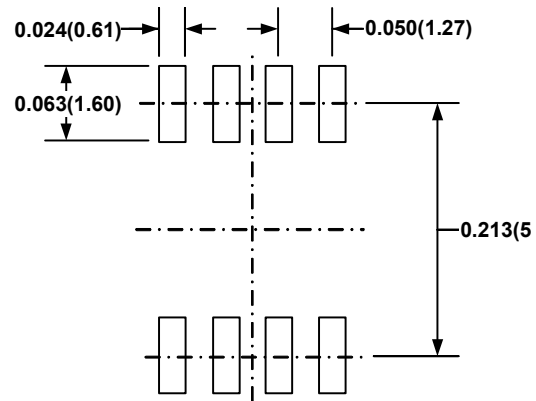

RECOMMENDED LAND PATTERN

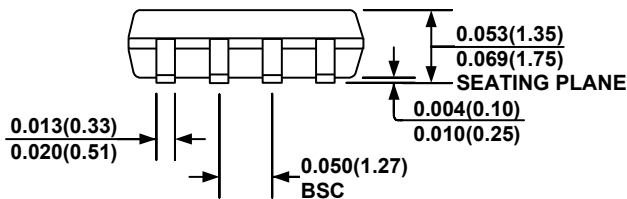

FRONT VIEW

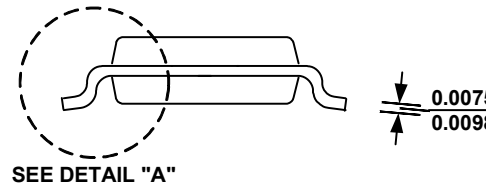

SIDE VIEW

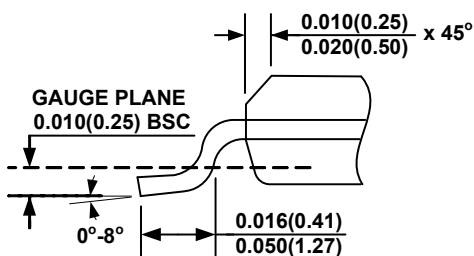

DETAIL "A"

NOTE:

- 1) CONTROL DIMENSION IS IN INCHES. DIMENSION IN BRACKET IS IN MILLIMETERS.
- 2) PACKAGE LENGTH DOES NOT INCLUDE MOLD FLASH, PROTRUSIONS OR GATE BURRS.
- 3) PACKAGE WIDTH DOES NOT INCLUDE INTERLEAD FLASH OR PROTRUSIONS.
- 4) LEAD COPLANARITY (BOTTOM OF LEADS AFTER FORMING) SHALL BE 0.004" INCHES MAX.
- 5) DRAWING CONFORMS TO JEDEC MS-012, VARIATION B.
- 6) DRAWING IS NOT TO SCALE.

NOTICE: The information in this document is subject to change without notice. Users should warrant and guarantee that third party Intellectual Property rights are not infringed upon when integrating MPS products into any application. MPS will not assume any legal responsibility for any said applications.