

## Technical Data:

### Material

- HOUSING: NYLON (Glass Filled) UL 94V-0.
- Metal Housing: Brass (Cu Zn) Ni, Tin plated

### Electrical:

- Current rating: 15 Amps / way max.
- Insulation resistance: 500M  $\Omega$  (min) / DC 500V.
- Withstanding Voltage: 1500VAC (minute). test time= 60sec/1pcs.
- Operation Voltage: 250 VAC.
- Wire Range: 12-24 AWG.

### Mechanical:

- Operating temperature:  $-50^{\circ}\text{C}$  to  $+105^{\circ}\text{C}$
- Solderability: 95 % coverage (Minumum). test temperature=  $230^{\circ}\text{C} \pm 10^{\circ}\text{C}$ .  
test time= 3sec  $\pm$  0.5sec.

## Application and Features:

- Nextron's two piece pluggable and fixed PCB terminal block is designed to plug on to loose pins or pin header strips.
- Configurations from 2-24 poles are available.
- The built in wire guard ensures that the screw does not press directly on the wire. Screw is available in both slot head and Philips design.
- The pluggable system is easy to use either horizontally or vertically. Various combinations for horizontal and vertical insertion to the PC Board are available.

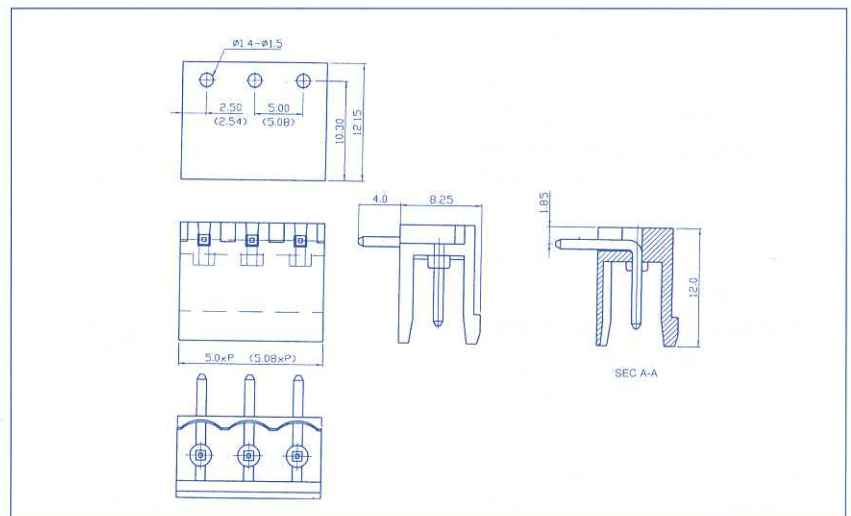

Notes: Please replace 'X' with appropriate coding listed in the tables below

2 9 1 - X X X - X X 0 0

### Number of contact

02-24 po	02
	03
	etc.

### Pitch

5.00mm/.197"	1
10.00mm/.394"	2
5.08mm/.200"	A
10.16mm/.400"	B

### Housing Type

Open	0
Close	1
Latch	2

### Color

Green	5
-------	---