

PART NUMBER	REV	FIRST USED	DESCRIPTION
1320999-1	R		ITEM 1 HOUSING FOR SET SCREW FEED TRACK
1320999-2	R		ITEM 1 HOUSING FOR SET SCREW FEED TRACK
1320999-3	U	-	ITEM 36 HOUSING FOR SPRING LOADED FEED TRACK
1320999-4	U	-	ITEM 36 HOUSING FOR SPRING LOADED FEED TRACK
1320999-5	N	-	SAME AS -3 LESS COUNTER
1320999-6	N	-	SAME AS -4 LESS COUNTER
1320999-7	U	-	SAME AS -3, INCLUDES MODIFIED BASE PLATE
1320999-8	U	-	SAME AS -3, FOR LARGE SEALS
1320999-9	U	-	SAME AS -3 W/MODIFIED HOUSING
1-1320999-0	U	-	KOMAX/PAWO/KIRSTEN
1-1320999-1	U	-	SIMILAR TO -3 W/ADDITIONAL ANVIL HOLE

SUPERSEDED BY -3
 SUPERSEDED BY -4
 SUPERSEDED BY -3
 SUPERSEDED BY -4

DETAIL C-C
 FEED ARM ALIGNMENT
 SCALE 3:2

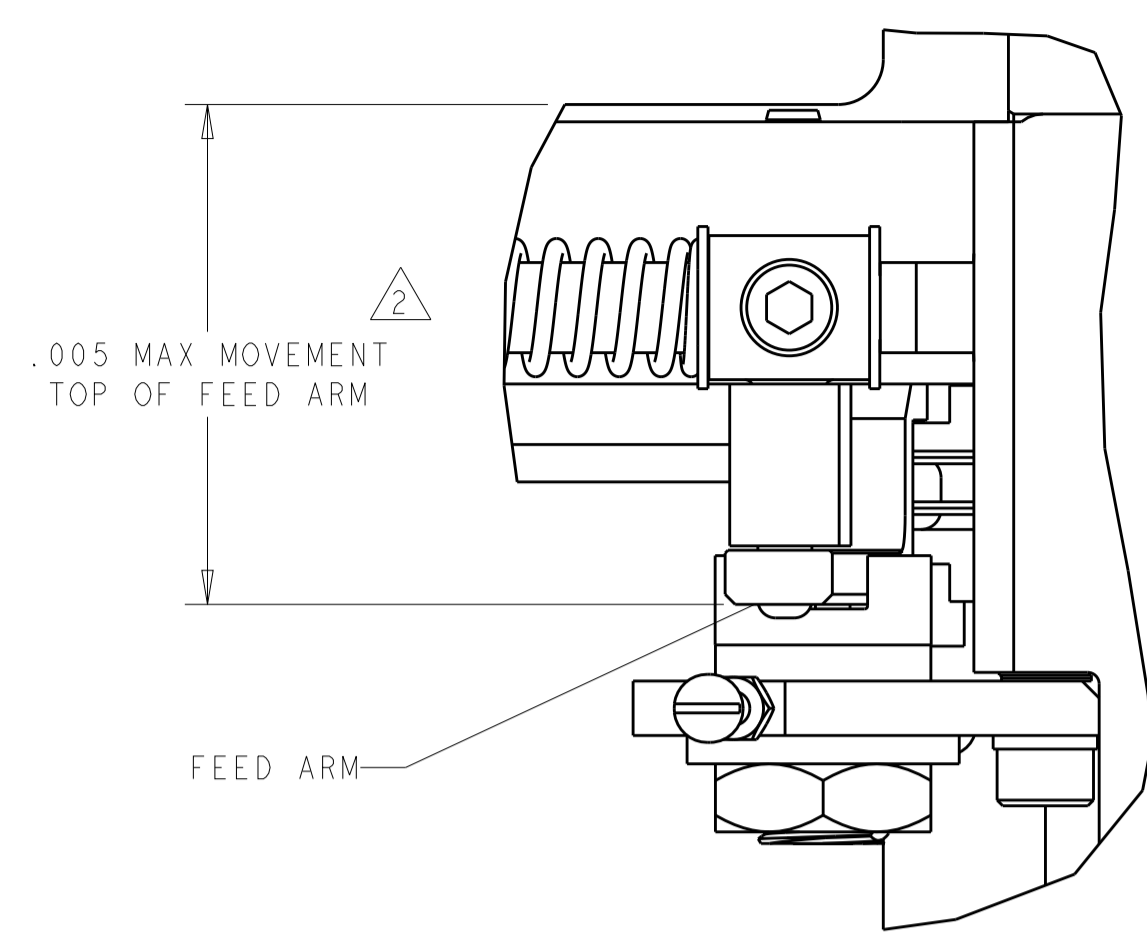

- 1 ROLLER MUST ROTATE AFTER ASSEMBLY
- 2 MODIFY LAMINATED SPACER AS REQUIRED TO REMOVE EXCESS CLEARANCE IN FEED LINKAGE
- 3 LUBRICATE USING #20 MACHINE OIL
- 4 IDENTIFY PART PER TEC-115-67-7
- 5 ALIGN HOUSING TO BASE PLATE USING ALIGNMENT GAGE 458637-3
- 6 FOR STAND ALONE COUNTER KIT PER PART NUMBER 1804312-1
- 7 ADD SHIM BETWEEN ITEMS 4 & 9 AS REQUIRED TO ELIMINATE SIDE TO SIDE MOVEMENT. (AS CLOSE TO ZERO AS POSSIBLE.)
- 8 THIS SUB-ASSEMBLY TO RUN ON THE FOLLOWING:
 KOMAX BT700 SSC
 KIRSTEN K750 STRIPPER CRIMPER SC
 PAWO BIG STRIPPER/SEALER/CRIMPER
 SCHLEUNIGER STRIP CRIMP Ø75.

THIS DRAWING IS A CONTROLLED DOCUMENT
 DIMENSIONING AND TOLERANCING PER ASME Y14.5M-2009

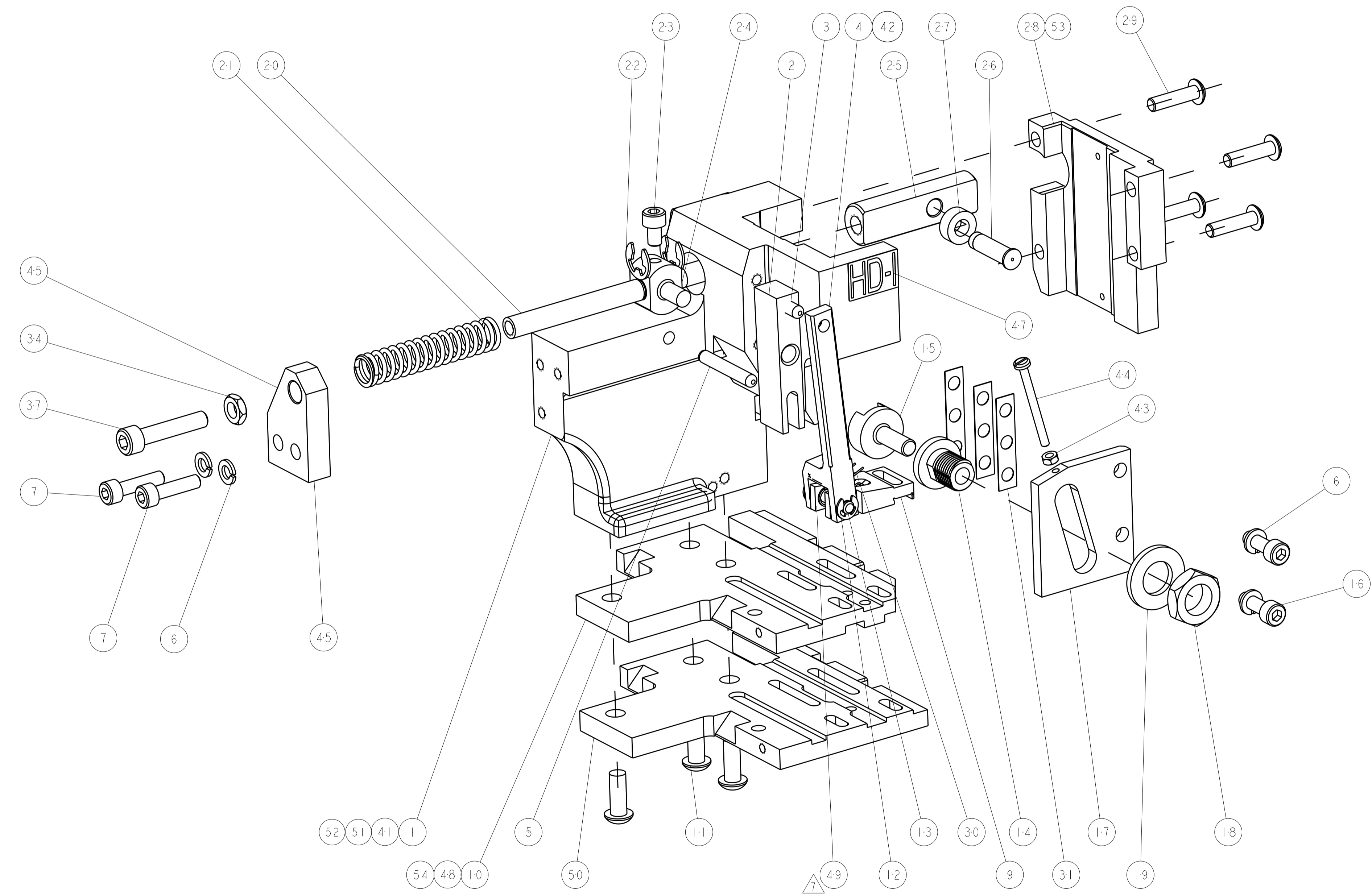

QTY	UNIT	DESCRIPTION	PART NO	ITEM NO
1		PLATE, BASE	1320992-5	54
1		CAP, RAM	879287-3	53
1		HOUSING, APPLICATOR	1803041-1	52
1		HOUSING, SIDE FEED, MODIFIED	1633862-1	51
1		PLATE, BASE	1320992-2	50
AR	AR	SHIM	519035-3	49
1		PLATE, BASE	1320992-3	48
1		LABEL, HD-1 APPLICATOR	2-1768826-7	47
1		SCREW, ADJUSTMENT	1338707-1	46
1		SUPPORT, SCREW ADJ	1338668-1	45
1		SCR, PAN SLT HD MACH M3 X 35.0	4-18019-4	44
1		NUT, HEX, REG M3	18030-1	43
1		ARM, FEED MACHINING	455679-2	42
1		HOUSING, SIDE FEED, HDD	1633074-1	41
1		SHCS, M6 X 30, SS	3-985563-1	37
1		NUT, HEX JAM M6 S.S.	1655639-1	34
AR	AR	SPACER, ADJ PLATE	690517-1	31
1		SPRING-FEED FINGER	240638-1	30
4	4	SCR, BTN SKT HD CAP (M5 X 20.0)	1-18024-4	29
1		CAP, RAM	454220-1	28
1		ROLLER-CAM	240658-1	27
1		PIN, CAM ROLLER	240659-3	26
1		ROD, FEED	1338677-2	25
1		BLOCK, PIVOT	1338674-1	24
1		SCR, SKT HD CAP M5 X 8.0	9-18023-5	23
2	2	E-RING (EXT. RETAIN. RING), METRIC	986963-8	22
1		SPRING, COMPRESSION	4-22284-9	21
1		SCREW, ADJUSTMENT	1804307-1	20
1		WASHER, FLAT, REG M12	18027-7	19
1		NUT, HEX, THIN M12X1.25	992326-6	18
1		PLATE, ADJUSTING	1338671-1	17
2	2	SCR, SKT HD CAP M5 X 16.0	2-18023-0	16
1		SHAFT-PIVOT AMP-O-MATOR	240626-1	15
1		BUSHING	1338670-1	14
1		PIN, FEED FINGER	1338672-1	13
2	2	E-RING (EXT. RETAIN. RING), METRIC	986963-2	12
3	3	SCR, BTN SKT HD CAP M6X16.0 W/NYLOK	994988-1	11
1		PLATE, BASE	1320992-1	10
1		HOLDER, FEED FINGER MACHINING	690541-1	9
2	2	SCR, SKT HD CAP M5 X 20.0	2-18023-1	7
4	4	WASHER, SPRG LOCK, REG M5	18025-3	6
1		PIN, DOWEL .1875 X 1.250	1-21030-6	5
1		ARM, FEED MACHINING	455679-1	4
1		PIN, DOWEL .1875 X .500	1-21030-1	3
1		LEVER, INTERMEDIATE	455680-1	2
1		HOUSING, SIDE FEED	1320991-1	1

SUPERSEDED BY -4
 SUPERSEDED BY -3
 SUPERSEDED BY -4
 SUPERSEDED BY -3

LOC A
 DIST 19

U	ECR-007472	03MAY2013	MY	GB	DIMENSIONS: IN TOLERANCES UNLESS OTHERWISE SPECIFIED: 0 PLC ±.0005 1 PLC ±.001 2 PLC ±.002 3 PLC ±.005 4 PLC ±.010 ANGLE: 0°30' SURFACE TEXTURE 125	APVD	30MAY05	CHK	TIM ELBIN	19MAY05	MATERIAL	HEAT TREAT	
T	ECR-11-021712	25OCT2011	BH	BH		APVD	30MAY05	CHK	T.BENCHOFF	NAME	APPLICATOR SUBASSEMBLY, HDI		
S	ECR-11-021672	25OCT2011	BH	BH		SCALE	1:1	SIZE	A1	DRAWING NO	1320999	SHEET	1 OF 1
P	LTR	REVISION RECORD	DATE	OWN		APVD							REV

