

MSM6576

Operatable at 0.9 V and 7-level Detector 4-Bit Microcontroller

GENERAL DESCRIPTION

MSM6576 is a 4-bit, low-power microcontroller that is manufactured in a CMOS silicon-gate process. The microcontroller can be started and operated at a low supply voltage of 0.9 V.

This device contains a crystal oscillator circuit, voltage converter circuits, a time base counter, a ROM, a RAM, a stack RAM, I/O ports, interrupt function components, a serial I/O port, a buzzer output circuit, a level detector, and a differential amplifier.

This IC is driven by one battery and is well suited to products that need to be operated under low power consumption.

FEATURES

- The IC can be initialized and operated even at a low voltage of 0.9 V.
- Low power consumption
- ROM : 2048 words × 17 bits
- RAM : 64 words × 4 bits
- I/O port
 - Input-output port : 7 ports × 4 bits
 - Input port : 1 port × 1 bit
- Interrupt functions (real-time interrupt, external interrupt, and serial interrupt)
- Serial I/O port : 8-bit sync communication
- Buzzer output circuit
- Level detector : 7-level detection
- Comparator
- 73 instructions
- Minimum instruction execution time : 61 μs
- Operation under single 1.5 V power supply
- Built-in 32.768 kHz crystal oscillator circuit
- Package options:
 - 44-pin plastic QFP (QFP44-P-910-0.80-K) (Product name : MSM6576-××GS-K)
 - 44-pin plastic QFP (QFP44-P-910-0.80-2K) (Product name : MSM6576-××GS-2K)
 - Chip

×× indicates a code number.

BLOCK DIAGRAM

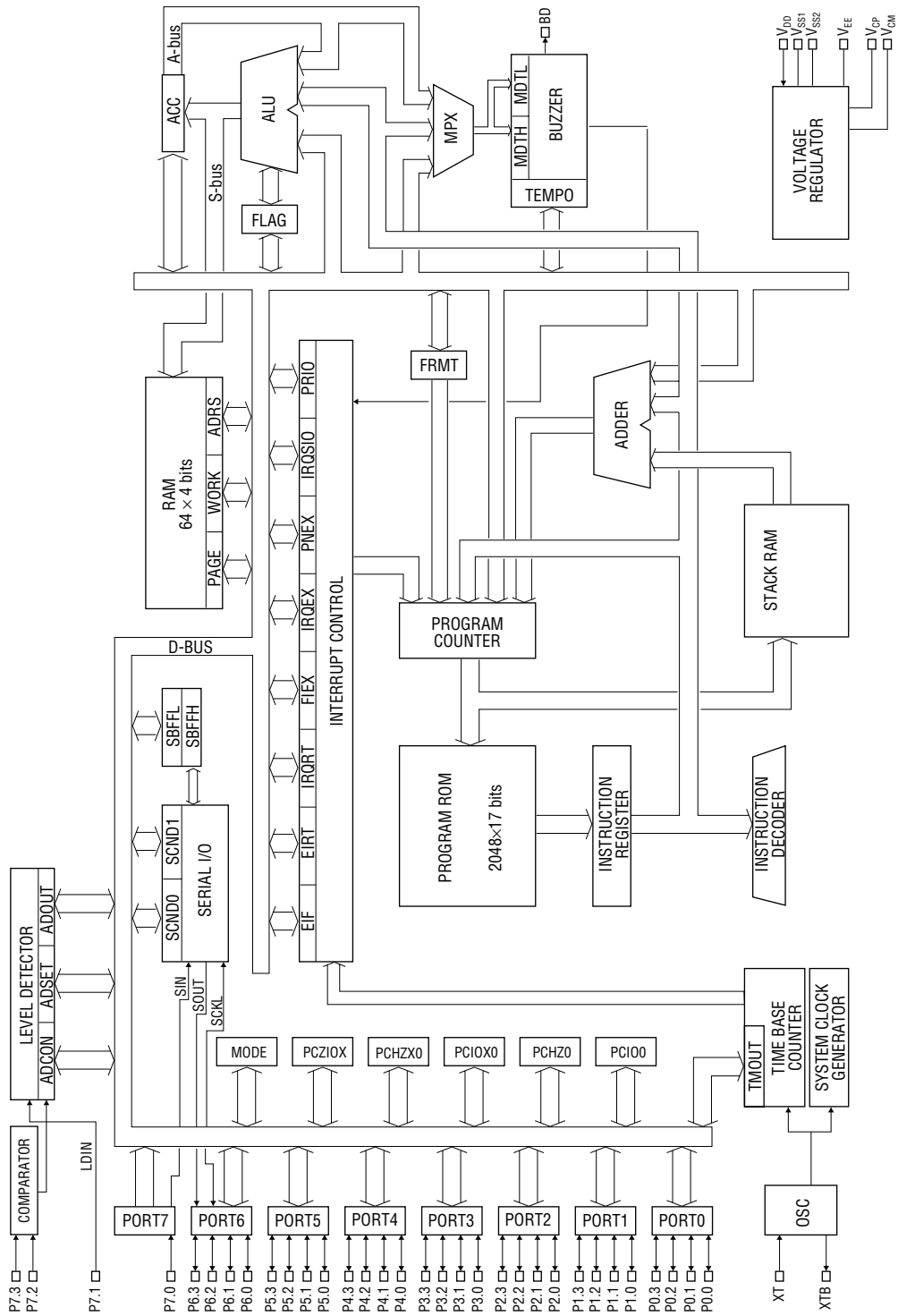

PIN CONFIGURATION (TOP VIEW)

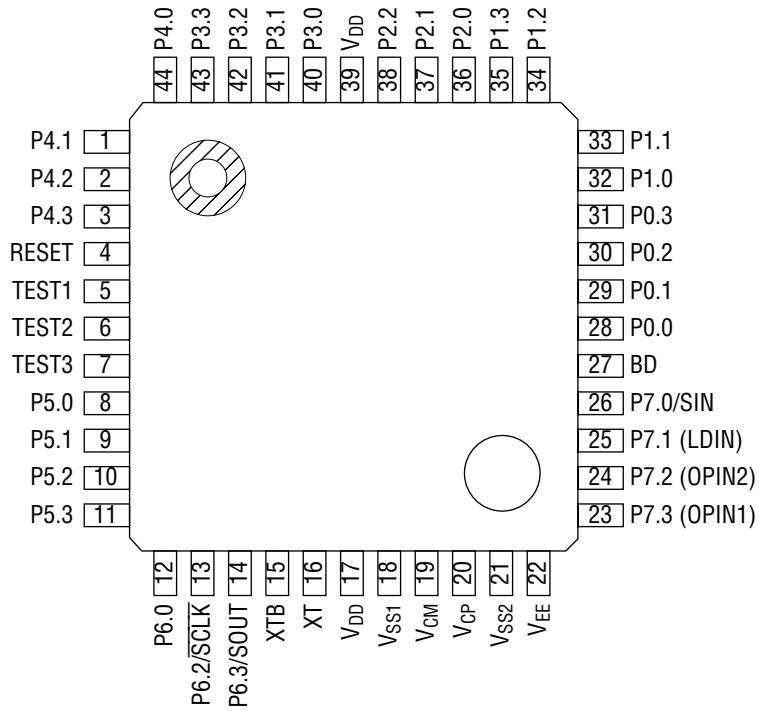

44-Pin Plastic QFP

- Notes: 1. P6.3, P7.0 and P7.1 are used as serial port pins as well.
 P7.2 and P7.3 are used as up/down counter pins as well.
 2. P6.1 is not assigned as a pin.

PIN DESCRIPTIONS

Symbol	Type	Description		
PORT0 (P0.0 to P0.3)	I/O	4-bit input-output port, I/O switchable, input pull-down resistor/pull-up resistor switchable, with/without input resistor		
PORT1 (P1.1 to P1.3)	I/O	4-bit input-output port, I/O switchable, with/without input pull-down resistor		
PORT2 (P2.0 to P2.3)	I/O	4-bit input-output port, I/O switchable, with/without input pull-down resistor	P2.0 to P2.3	External interrupt port
PORT3 (P3.0 to P3.3)	I/O	4-bit input-output port, I/O switchable, with/without input pull-down resistor		
PORT4 (P4.0 to P4.3)	I/O	4-bit input-output port, I/O switchable, with/without input pull-down resistor		
PORT5 (P5.0 to P5.3)	I/O	4-bit input-output port, I/O switchable, with/without input pull-down resistor		
PORT6 (P6.0 to P6.3)	I/O	4-bit input-output port, I/O switchable, with/without input pull-down resistor	P6.3: SOUT	Shared with serial port
			P6.2: $\overline{\text{SCLK}}$	
PORT7 (P7.0 to P7.3)	I	P7.0: Input port, without input resistor	P7.0: SIN	
		P7.1: Input pin for level detector		
		P7.2: Input pin for comparator		
		P7.3: Input pin for comparator		
BD	O	Buzzer output pin		
RESET	I	Reset pin with input pull-down resistor		
TEST1 TEST2 TEST3	I	Testing pins with input pull-down resistor Tie to the negative pole of the battery.		
XT	I	Connection pins for crystal		
XTB	O			
V _{DD}	—	0 V power supply pin		
V _{SS1}	—	-1.5 V supply pin (power supply pin for -1.5 V operation)		
V _{SS2}	—	-3.0 V supply pin (power supply pin for -3.0 V operation)		
V _{CP}	—	Connection pins for internal potential development capacitor		
V _{CM}				
V _{EE}	—	Supply pin for internal logic (constant voltage circuit output pin)		

ABSOLUTE MAXIMUM RATINGS

1.5 V operation

Backup flag (BUF) = "0"

The input of the constant voltage circuit is equal to the output of the voltage converter (V_{SS2}).

$V_{DD} = 0\text{ V}$ (V_{SS1} = battery voltage)

Parameter	Symbol	Condition	Rating	Unit
Power Supply Voltage	V_{SS1}	$T_a = 25^\circ\text{C}$	-6.0 to +0.3	V
Input Voltage	V_{IN}		$V_{SS1} - 0.3$ to +0.3	
Output Voltage	V_{OUT}		$V_{SS1} - 0.3$ to +0.3	
Storage Temperature	T_{STG}	—	-55 to +150	$^\circ\text{C}$

RECOMMENDED OPERATING CONDITIONS

1.5 V operation

Backup flag (BUF) = "0"

The input of the constant voltage circuit is equal to the output of the voltage converter (V_{SS2}).

$V_{DD} = 0\text{ V}$ (V_{SS1} = battery voltage)

Parameter	Symbol	Condition	Range	Unit
Operating Voltage	V_{op}	—	-3.5 to -0.9	V
Operating Temperature	T_{op}	—	-20 to +70	$^\circ\text{C}$
Oscillation Frequency	f_{osc}	—	32.768	kHz

ELECTRICAL CHARACTERISTICS

1.5 V operation

Backup flag (BUF) = "0"

The input of the constant voltage circuit is equal to the output of the voltage converter (V_{SS2}).
 ($V_{DD} = 0\text{ V}$, $V_{SS1} = -1.5\text{ V}$ (battery voltage), $V_{SS2} = -3.0\text{ V}$, $f_{OSC} = 32.768\text{ kHz}$, $C_X = 35\text{ pF}$, $T_a = 25^\circ\text{C}$)

Parameter	Symbol	Condition	Min.	Typ.	Max.	Unit	Applied Pin
Power Supply Current 1 *1	I_{DD1}	Level detector OFF	—	3	—	μA	—
Power Supply Current 2 *1	I_{DD2}	Level detector ON	—	15	—	μA	—
Oscillation Start Voltage	$-V_{OSC}$	Within 2 seconds	—	—	0.9	V	V_{SS1}
Output Current 1	$-I_{OH1}$	$V_0 = -0.5\text{ V}$	150	—	—	μA	PORT0 to PORT6 *2 SOUT, SCLK
	I_{OL1}	$V_0 = -1.0\text{ V}$	150	—	—		
Output Current 2	$-I_{OH2}$	$V_0 = -0.5\text{ V}$	20	—	—	μA	BD
	I_{OL2}	$V_0 = -1.0\text{ V}$	20	—	—		
Input Current 1	I_{IH1}	$V_1 = 0\text{ V}$, in the input state, with pull-down resistor	3.75	7.5	15	μA	PORT0 to PORT6 *2
Input Current 2	$-I_{IH2}$	$V_1 = -1.5\text{ V}$, in the input state, with pull-up resistor	3.75	7.5	15	μA	PORT0
Input Leakage Current	$ I_{IL} $	$V_1 = 0\text{ V}$, -1.5 V , in the input state, without pull-down resistor	—	—	1	μA	PORT0 to PORT7 *2 SIN, SOUT, SCLK
Input Current 3	I_{IH3}	$V_1 = -0\text{ V}$, with pull-down resistor	70	250	500	μA	RESET, TEST1 to TEST3
Input Voltage	$-V_{IH}$	—	—	—	0.3	V	All input pins
	$-V_{IL}$	—	1.2	—	—		
Level Detector Off Voltage	$-V_{LDoff}$	ADSTART = "0"	0	—	80	mV	P7.1
Level Detector Detecting Voltage	$-V_{LD6H}$	(ADOUT) = 6H	725	742	759	mV	
	$-V_{LD5H}$	(ADOUT) = 5H	841	858	875		
	$-V_{LD4H}$	(ADOUT) = 4H	958	975	992		
	$-V_{LD3H}$	(ADOUT) = 3H	1075	1092	1109		
	$-V_{LD2H}$	(ADOUT) = 2H	1191	1208	1225		
	$-V_{LD1H}$	(ADOUT) = 1H	1308	1325	1342		
$-V_{LD0H}$	(ADOUT) = 0H	1425	1442	1459			
Level Detector Settling Time	t_{SET}	ADSTART = "1", during OUT ADSET execution	—	—	61	μs	
Level Detector Conversion Rate	f_{LD}	—	—	—	100	Hz	
Comparator Offset Voltage	$-V_{CMPoff}$	—	—	—	15	mV	P7.3, P7.2
Comparator Input Voltage	$-V_{CMPin}$	$-V_B = \text{Battery voltage}$	$V_B/2$	—	V_B	V	
Comparator Conversion Rate	f_{CMP}	—	—	—	100	Hz	

*1 Depends on program. (Values in the above table are applied in the case where the software duty is about 3%.)

*2 PORT0 = P0.0 to P0.3, PORT1 = P1.0 to P1.3, PORT2 = P2.0 to P2.3, PORT3 = P3.0 to P3.3, PORT4 = P4.0 to P4.3, PORT5 = P5.0 to P5.3, PORT6 = P6.0 to P6.3, PORT7 = P7.0 to P7.3

ABSOLUTE MAXIMUM RATINGS

1.5 V operation

Backup flag (BUF) = "1"

The input of the constant voltage circuit is directly connected to the power supply (V_{SS1}).

$V_{DD} = 0\text{ V}$ (V_{SS1} = battery voltage)

Parameter	Symbol	Condition	Rating	Unit
Power Supply Voltage	V_{SS1}	$T_a = 25^\circ\text{C}$	-6.0 to +0.3	V
Input Voltage	V_{IN}		$V_{SS1} - 0.3$ to +0.3	
Output Voltage	V_{OUT}		$V_{SS1} - 0.3$ to +0.3	
Storage Temperature	T_{STG}	—	-55 to +150	$^\circ\text{C}$

RECOMMENDED OPERATING CONDITIONS

1.5 V operation

Backup flag (BUF) = "1"

The input of the constant voltage circuit is directly connected to the power supply (V_{SS1}).

$V_{DD} = 0\text{ V}$ (V_{SS1} = battery voltage)

Parameter	Symbol	Condition	Range	Unit
Operating Voltage	V_{op}	—	-3.5 to -0.9	V
Operating Temperature	T_{op}	—	-20 to +70	$^\circ\text{C}$
Oscillation Frequency	f_{osc}	—	32.768	kHz

ELECTRICAL CHARACTERISTICS

1.5 V operation

Backup flag (BUF) = "1"

The input of the constant voltage circuit is directly connected to the power supply (V_{SS1}).

(V_{DD} = 0 V, V_{SS1} = -1.5 V (battery voltage), V_{SS2} = -3.0 V, f_{OSC} = 32.768 kHz, C_X = 35 pF, Ta = 25°C)

Parameter	Symbol	Condition	Min.	Typ.	Max.	Unit	Applied Pin
Power Supply Current 1	*1 I _{DD1}	Level detector OFF	—	1.5	—	μA	—
Power Supply Current 2	*1 I _{DD2}	Level detector ON	—	13.5	—	μA	—
Oscillation Start Voltage	-V _{OSC}	Within 2 seconds	—	—	0.9	V	V _{SS1}
Output Current 1	-I _{OH1}	V _O = -0.5 V	150	—	—	μA	PORT0 to PORT6*2 SOUT, SCLK
	I _{OL1}	V _O = -1.0 V	150	—	—		
Output Current 2	-I _{OH2}	V _O = -0.5 V	20	—	—	μA	BD
	I _{OL2}	V _O = -1.0 V	20	—	—		
Input Current 1	I _{IH1}	V _I = 0 V, in the input state, with pull-down resistor	3.75	7.5	15	μA	PORT0 to PORT6 *2
Input Current 2	-I _{IH2}	V _I = -1.5 V, in the input state, with pull-up resistor	3.75	7.5	15	μA	PORT0
Input Leakage Current	I _{IL}	V _I = 0 V, -1.5 V, in the input state, without pull-down resistor	—	—	1	μA	PORT0 to PORT7*2 SIN, SOUT, SCLK
Input Current 3	I _{IH3}	V _I = 0 V, with pull-down resistor	70	250	500	μA	RESET, TEST1 to TEST3
Input Voltage	-V _{IH}	—	—	—	0.3	V	All input pins
	-V _{IL}	—	1.2	—	—		
Level Detector Off Voltage	-V _{LDoff}	ADSTART = "0"	0	—	80	mV	P7.1
Level Detector Detecting Voltage	-V _{LD6H}	(ADOUT) = 6 _H	725	742	759	mV	
	-V _{LD5H}	(ADOUT) = 5 _H	841	858	875		
	-V _{LD4H}	(ADOUT) = 4 _H	958	975	992		
	-V _{LD3H}	(ADOUT) = 3 _H	1075	1092	1109		
	-V _{LD2H}	(ADOUT) = 2 _H	1191	1208	1225		
	-V _{LD1H}	(ADOUT) = 1 _H	1308	1325	1342		
-V _{LD0H}	(ADOUT) = 0 _H	1425	1442	1459			
Level Detector Settling Time	t _{SET}	ADSTART = "1", during OUT ADSET execution	—	—	61	μs	
Level Detector Conversion Rate	f _{LD}	—	—	—	100	Hz	
Comparator Offset Voltage	-V _{CMPoff}	—	—	—	15	mV	P7.3, P7.2
Comparator Input Voltage	-V _{CMPin}	-V _B = Battery voltage	V _B /2	—	V _B	V	
Comparator Conversion Rate	f _{CMP}	—	—	—	100	Hz	

*1 Depends on program. (Values in the above table are applied in the case where the software duty is about 3%.)

*2 PORT0 = P0.0 to P0.3, PORT1 = P1.0 to P1.3, PORT2 = P2.0 to P2.3, PORT3 = P3.0 to P3.3, PORT4 = P4.0 to P4.3, PORT5 = P5.0 to P5.3, PORT6 = P6.0 to P6.3, PORT7 = P7.0 to P7.3

NOTES ON USE

Power Supply for 0.9 V Microcontroller Series (Backup Flag and Constant-Voltage Circuit)

The 0.9 V microcontroller series has built-in constant-voltage circuit. The output of this constant-voltage circuit powers the microcontroller's internal logic circuits. Setting a backup flag (BUF) allows the input of the constant-voltage circuit to be switched to either the battery or the output generated in the voltage converter, based on the battery voltage. A battery voltage is 1.5 V.

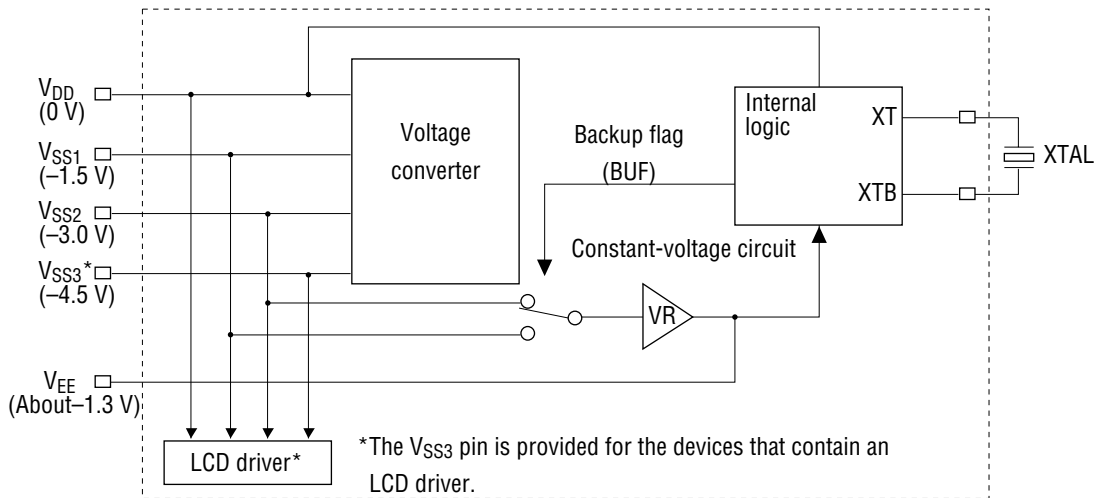

The output (V_{EE}) of the constant-voltage circuit is set at approximately -1.3 V. This allows the current consumed by the internal logic to be limited, irrespective of the battery voltage. However, if the input of the constant-voltage circuit is below this set value (about -1.3 V), the output (V_{EE}) is equal to the input. The 0.9 V microcontroller can be operated even if the internal voltage (output from the constant-voltage circuit) falls to 0.9 V. Setting the backup flag allows a larger operating voltage margin despite changes in internal voltage due to noise. For example, for the 1.5 V operation, setting the backup flag to "0" supplies twice the battery voltage to the constant-voltage circuit. Thus, even if the battery voltage falls to 0.9 V, the output voltage (V_{EE}) is maintained at -1.3 V, providing a larger margin of operating voltage of the internal logic circuits because 1.8 V is applied to the input of the constant-voltage circuit. Figures 1 and 2 show the internal status depending on the backup flag settings for the battery, as well as status features.

(Figure 1) 1.5 V Operation (Backup Flag = "1")

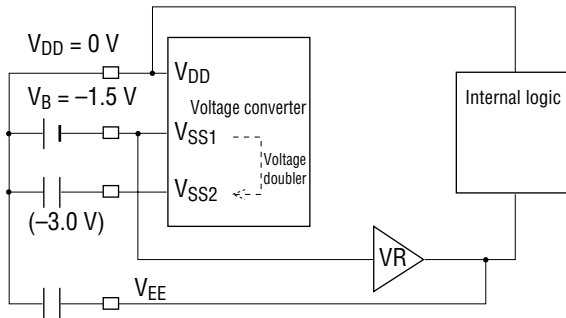

Internal status	The battery level V_{SS1} is applied to the input of the constant-voltage circuit. (V_{SS2}).
Operating range	-0.9 to -3.5 V
Current consumption	1.5 μA^*
Feature	When the battery level is powered down, the internal circuit is powered directly by the battery.

* When the software duty is about 5%

(Figure 2) 1.5 V Operation (Backup Flag = "0")

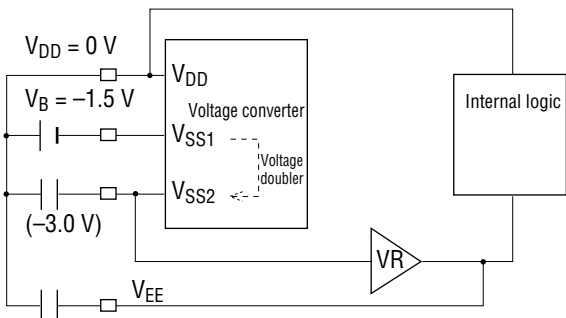

Internal status	A doubled level of V_{SS2} is applied to the input of the constant-voltage circuit. (V_{SS2}).
Operating range	-0.9 to -3.5 V
Current consumption	3 μA^*
Feature	When the battery level is powered down, a larger operating voltage margin is gained, compared to the case of Figure 1.

* When the software duty is about 5%

PACKAGE DIMENSIONS

(Unit : mm)

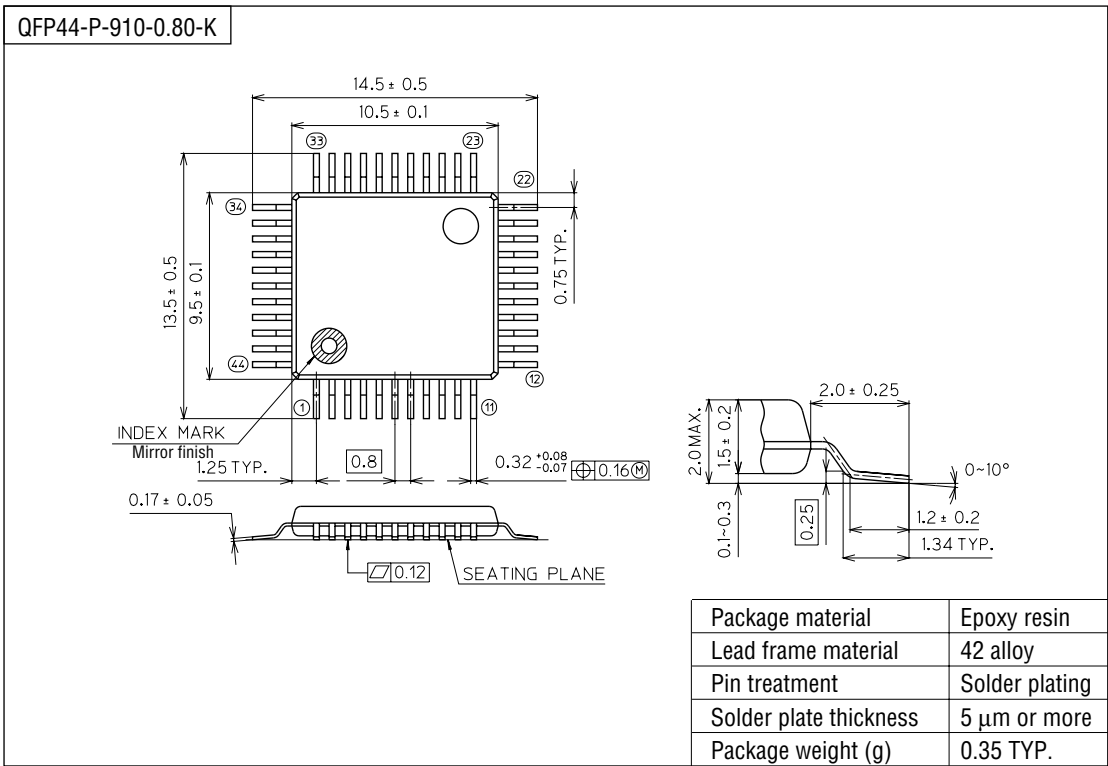

Notes for Mounting the Surface Mount Type Package

The SOP, QFP, TSOP, SOJ, QFJ (PLCC), SHP and BGA are surface mount type packages, which are very susceptible to heat in reflow mounting and humidity absorbed in storage. Therefore, before you perform reflow mounting, contact Oki's responsible sales person for the product name, package name, pin number, package code and desired mounting conditions (reflow method, temperature and times).

(Unit : mm)

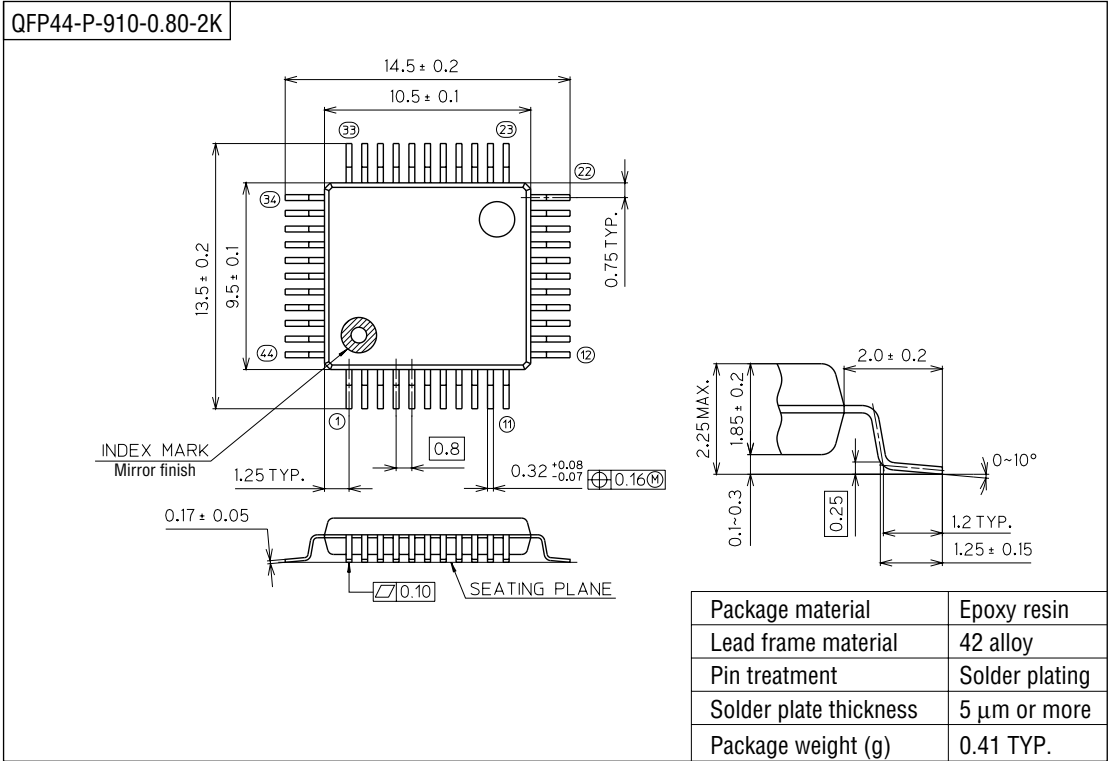

Notes for Mounting the Surface Mount Type Package

The SOP, QFP, TSOP, SOJ, QFJ (PLCC), SHP and BGA are surface mount type packages, which are very susceptible to heat in reflow mounting and humidity absorbed in storage. Therefore, before you perform reflow mounting, contact Oki's responsible sales person for the product name, package name, pin number, package code and desired mounting conditions (reflow method, temperature and times).