

2.7 V TO 5.5 V, 12- AND 10-BIT OCTAL DAC IN WAFER CHIP SCALE PACKAGE

FEATURES

- Eight Voltage Output DACs in One Package
 - TLV5610IYE . . . 12-Bit
 - TLV5608IYE . . . 10-Bit
- Programmable Settling Time vs Power Consumption
 - 1 μ s in Fast Mode
 - 3 μ s in Slow Mode
- Compatible With TMS320™ DSP Family and SPI Serial Ports
- Monotonic Over Temperature
- Low Power Consumption:
 - 18 mW in Slow Mode at 3 V
 - 48 mW in Fast Mode at 3 V
- Power Down Mode
- Buffered, High Impedance Reference Inputs
- Data Output for Daisy Chainin

APPLICATIONS

- Digital Servo Control Loops
- Digital Offset and Gain Adjustment
- Industrial Process Control
- Machine and Motion Control Devices
- Mass Storage Devices

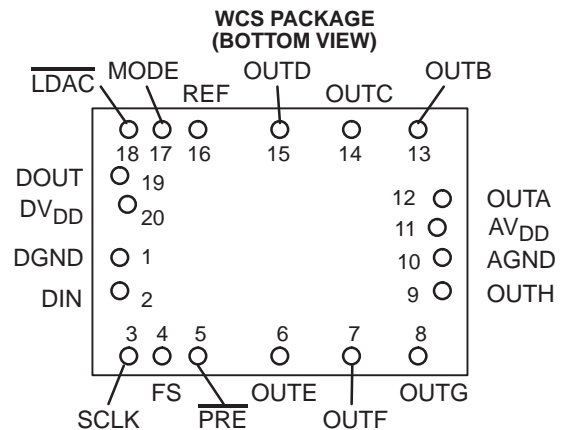

DESCRIPTION

The TLV5610IYE and TLV5608IYE are pin compatible eight channel 12-/10-bit voltage output DACs each with a flexible serial interface. The serial interface allows glueless interface to TMS320 and SPI, QSPI, and Microwire serial ports. It is programmed with a 16-bit serial string containing 4 control and 12 data bits.

Additional features are a power-down mode, an $\overline{\text{LDAC}}$ input for simultaneous update of all eight DAC outputs, and a data output which can be used to cascade multiple devices.

The resistor string output voltage is buffered by a rail-to-rail output amplifier with a programmable settling time to allow the designer to optimize speed vs power dissipation. The buffered, high-impedance reference input can be connected to the supply voltage.

The TLV5610IYE and TLV5608IYE implemented with a CMOS process and are available in a 20-terminal WCS package. The TLV5610IYE and TLV5608IYE are characterized for operation from -40°C to 85°C in a wire-bonded small outline (SOIC) package.



Please be aware that an important notice concerning availability, standard warranty, and use in critical applications of Texas Instruments semiconductor products and disclaimers thereto appears at the end of this data sheet.

TMS320 DSP is a trademark of Texas Instruments.



These devices have limited built-in ESD protection. The leads should be shorted together or the device placed in conductive foam during storage or handling to prevent electrostatic damage to the MOS gates.

AVAILABLE OPTIONS

T _A	PACKAGE
	WCS(1) (YE)
-40°C to 85°C	TLV5610IYE
	TLV5608IYE

(1) Wafer chip scale package. See Figure 13.

FUNCTIONAL BLOCK DIAGRAM

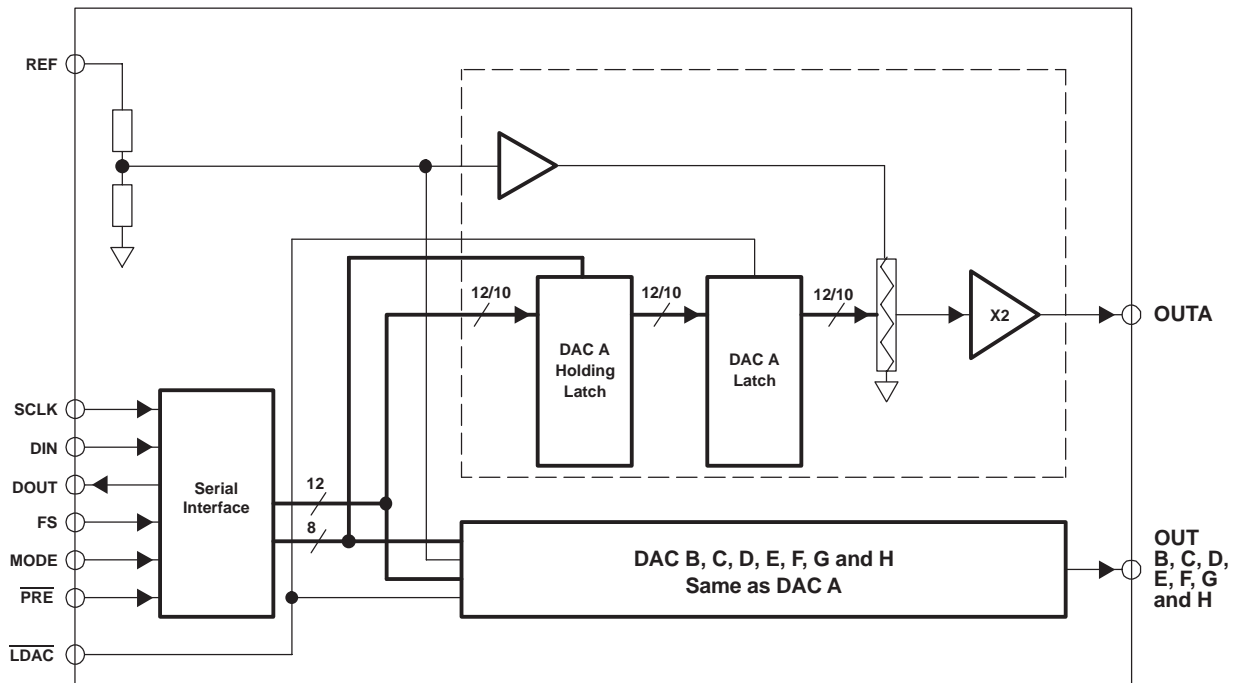

Terminal Functions

TERMINAL NAME	NO.	I/O	DESCRIPTION
AGND	10	P	Analog ground
AVDD	11	P	Analog power supply
DGND	1	P	Digital ground
DIN	2	I	Digital serial data input
DOUT	19	O	Digital serial data output
DVDD	20	P	Digital power supply
FS	4	I	Frame sync input
LDAC	18	I	Load DAC. The DAC outputs are only updated, if this signal is low. It is an asynchronous input.
MODE	17	I	DSP/μC mode pin. High = μC mode, NC = DSP mode.
PRE	5	I	Preset input
REF	16	I	Voltage reference input
SCLK	3	I	Serial clock input
OUTA–OUTH	12–15, 6–9	O	DAC outputs A, B, C, D, E, F, G and H

ABSOLUTE MAXIMUM RATINGS

over operating free-air temperature range unless otherwise noted⁽¹⁾

	UNIT
Supply voltage, (AV _{DD} , DV _{DD} to GND)	7 V
Reference input voltage range	- 0.3 V to AV _{DD} + 0.3
Digital input voltage rang	- 0.3 V to DV _{DD} + 0.3
Operating free-air temperature range, T _A	-40°C to 85°C

(1) Stresses beyond those listed under “absolute maximum ratings” may cause permanent damage to the device. These are stress ratings only, and functional operation of the device at these or any other conditions beyond those indicated under “recommended operating conditions” is not implied. Exposure to absolute-maximum-rated conditions for extended periods may affect device reliability.

RECOMMENDED OPERATING CONDITIONS

		MIN	TYP	MAX	UNIT
Supply voltage, AV _{DD} , AV _{DD}	5-V operation	4.5	5	5.5	V
	3-V operation	2.7	3	3.3	V
High level digital input, V _{IH}	DV _{DD} = 2.7 V to 5.5 V	2			V
Low level digital input, V _{IL}	DV _{DD} = 2.7 V to 5.5 V			0.8	V
Reference voltage, V _{ref}	AV _{DD} = 5 V	GND	4.096	AV _{DD}	V
	AV _{DD} = 3 V	GND	2.048	AV _{DD}	
Load resistance, R _L		2			kΩ
Load capacitance, C _L				100	pF
Clock frequency, f _{CLK}				30	MHz
Operating free-air temperature, T _A		-40		85	°C

ELECTRICAL CHARACTERISTICS

over operating free-air temperature range unless otherwise noted⁽¹⁾

POWER-SUPPLY				MIN	TYP	MAX	UNIT
PARAMETER	TEST CONDITIONS						
I _{DD} Power supply current	No load, All inputs = DV _{DD} or GND	V _{ref} = 4.096 V,	Fast		16	21	mA
			Slow		6	8	
Power-down supply current					0.1		μA
POR Power on threshold					2		V
PSRR Power supply rejection ratio	Full scale, See Note 1					-60	dB

STATIC DAC SPECIFICATIONS

		TLV5610IYE	TLV5608IYE	MIN	TYP	MAX	UNIT
Resolution					12		Bits
					10		
INL Integral nonlinearity	V _{ref} = 2 V, 4 V	TLV5610IYE	Code 40 to 4095		±2	±6	LSB
		TLV5608IYE	Code 20 to 1023		±0.5	±2	
DNL Differential nonlinearity	V _{ref} = 2 V, 4 V	TLV5610IYE	Code 40 to 4095		±0.5	±1	LSB
		TLV5608IYE	Code 20 to 1023		±0.1	±1	
E _{ZS} Zero scale error (offset error at zero scale)						±30	mV
E _{ZS TC} Zero scale error temperature coefficient						30	μV/°C
E _G Gain error						±0.6	%Full Scale V
E _{GTC} Gain error temperature coefficient						10	ppm/°C

(1) Power supply rejection ratio at full scale is measured by varying AV_{DD} and is given by:

$$PSRR = 20 \log [(E_G(AV_{DDmax}) - E_G(AV_{DDmin})) / V_{DDmax}]$$

ELECTRICAL CHARACTERISTICS (CONTINUED)

over operating free-air temperature range unless otherwise noted⁽¹⁾

OUTPUT SPECIFICATIONS						
PARAMETER		TEST CONDITIONS	MIN	TYP	MAX	UNIT
V _O	Voltage output range	R _L = 10 kΩ	0		AV _{DD} -0.4	V
	Output load regulation accuracy	R _L = 2 kΩ vs 10 kΩ			±0.3	%Full Scale V

REFERENCE INPUT						
PARAMETER		TEST CONDITIONS	MIN	TYP	MAX	UNIT
V _I	Input voltage range		0		AV _{DD}	V
R _I	Input resistance			100		kΩ
C _i	Input capacitance			5		pF
	Reference input bandwidth	V _{ref} = 0.4 V _{pp} + 2.048 Vdc, Input code = 0x800	Fast	2.2		MHz
			Slow	1.9		MHz
	Reference feedthrough	V _{ref} = 2 V _{pp} at 1 kHz + 2.048 Vdc (see Note 1)		-84		dB

(1) Reference feedthrough is measured at the DAC output with an input code = 0x000.

DIGITAL INPUTS						
PARAMETER		TEST CONDITIONS	MIN	TYP	MAX	UNIT
I _{IH}	High-level digital input current	V _I = DV _{DD}			1	μA
I _{IL}	Low-level digital input current	V _I = 0 V	-1			μA
C _i	Input capacitance			8		pF

DIGITAL OUTPUTS						
PARAMETER		TEST CONDITIONS	MIN	TYP	MAX	UNIT
V _{OH}	High-level digital output voltage	R _L = 10 kΩ	2.6			V
V _{OL}	Low-level digital output voltage	R _L = 10 kΩ			0.4	V
	Output voltage rise time	R _L = 10 kΩ, C _L = 20 pF, Includes propagation delay		7	20	ns

ANALOG OUTPUT DYNAMIC PERFORMANCE						
PARAMETER		TEST CONDITIONS	MIN	TYP	MAX	UNIT
t _s (FS)	Output settling time, full scale	R _L = 10 kΩ, C _L = 100 pF, See Note 1	Fast	1	3	μs
			Slow	3	7	
t _s (CC)	Output settling time, code to code	R _L = 10 kΩ, C _L = 100 pF, See Note 2	Fast	0.5	1	μs
			Slow	1	2	
SR	Slew rate	R _L = 10 kΩ, C _L = 100 pF, See Note 3	Fast	4	10	V/μs
			Slow	1	3	
	Glitch energy	See Note 4		4		nV-s
	Channel crosstalk	10 kHz sine, 4 V _{pp}		-90		dB

(1) Settling time is the time for the output signal to remain within ±0.5 LSB of the final measured value for a digital input code change of 0x80 to 0xFFFF and 0xFFFF to 0x080 respectively. Assured by design; not tested.

(2) Settling time is the time for the output signal to remain within ±0.5 LSB of the final measured value for a digital input code change of one count. The max time applies to code changes near zero scale or full scale. Assured by design; not tested.

(3) Slew rate determines the time it takes for a change of the DAC output from 10% to 90% full scale voltage.

(4) Code transition: TLV5610IYE – 0x7FF to 0x800, TLV5608IYE – 0x7FC to 0x800.

DIGITAL INPUT TIMING REQUIREMENTS

PARAMETER		MIN	TYP	MAX	UNIT
$t_{su}(FS-CK)$	Setup time, FS low before first negative SCLK edge	8			ns
$t_{su}(C16-FS)$	Setup time, 16 th negative edge after FS low on which bit D0 is sampled before rising edge of FS. μ C mode only	10			ns
$t_{wL}(LDAC)$	\overline{LDAC} duration low	10			ns
t_{wH}	SCLK pulse duration high	16			ns
t_{wL}	SCLK pulse duration low	16			
$t_{su}(D)$	Setup time, data ready before SCLK falling edge	8			ns
$t_h(D)$	Hold time, data held valid after SCLK falling edge	5			ns
$t_{wH}(FS)$	FS duration high	10			ns
$t_{wL}(FS)$	FS duration low	10			ns
t_s	Settling time	See AC specs			

TYPICAL CHARACTERISTICS

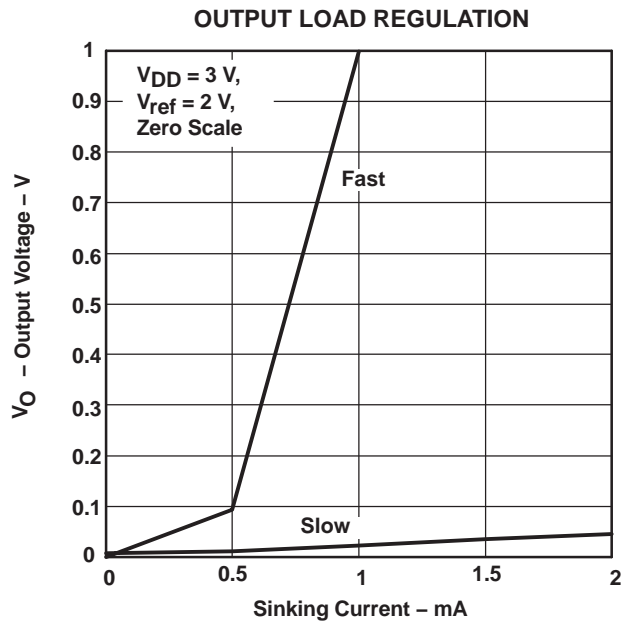

Figure 1

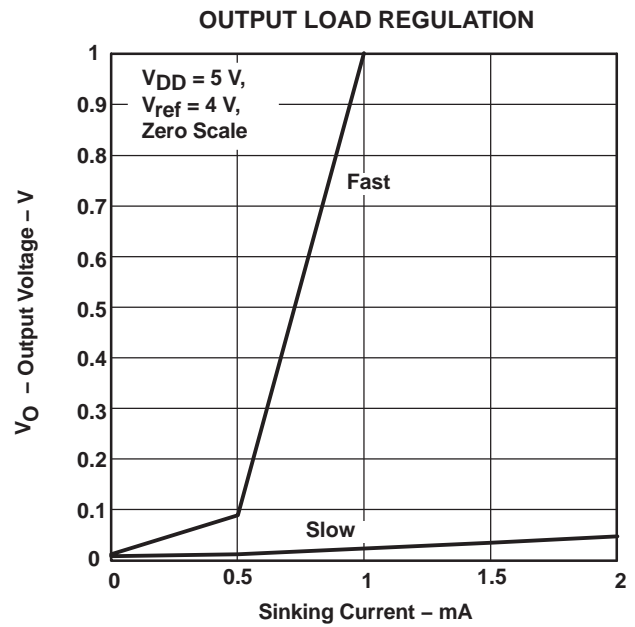

Figure 2

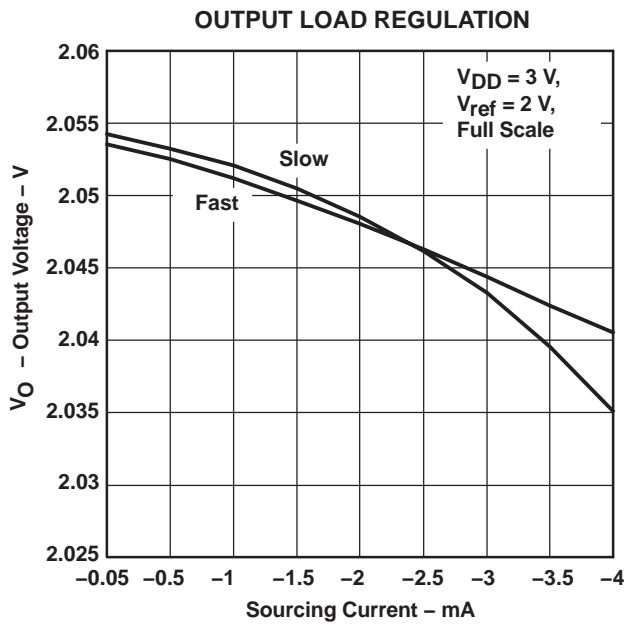

Figure 3

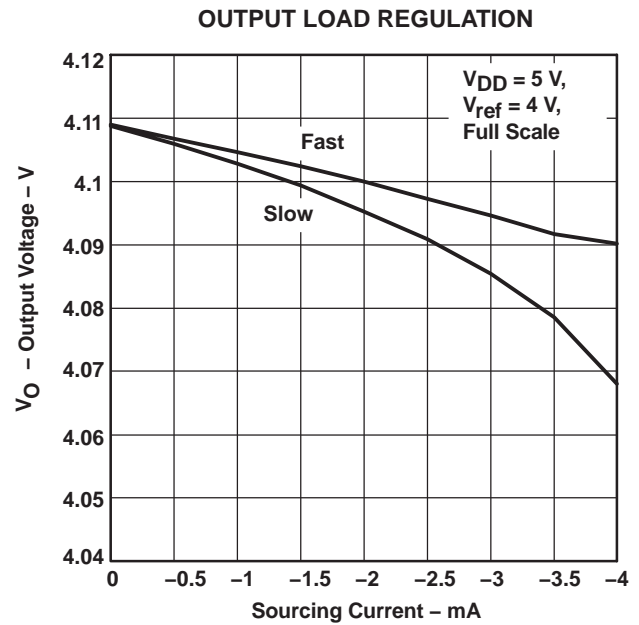

Figure 4

TLV5610IYE
INTEGRAL NONLINEARITY
vs
CODE

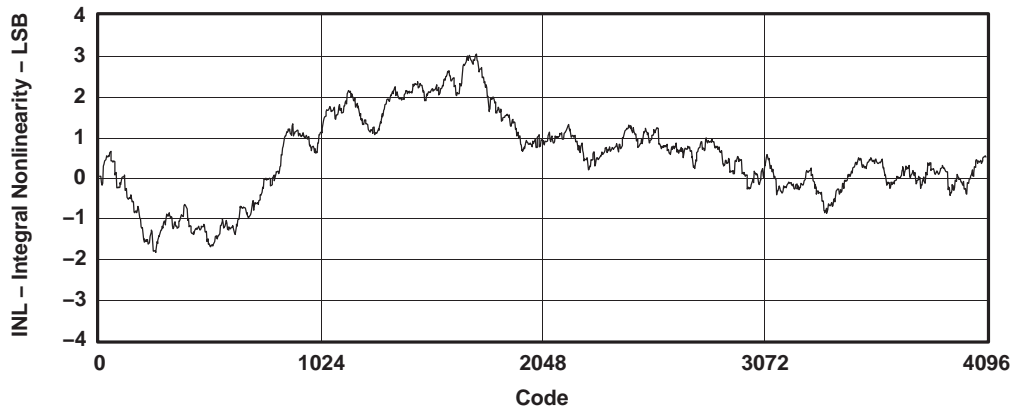

Figure 5

TLV5610IYE
DIFFERENTIAL NONLINEARITY
vs
CODE

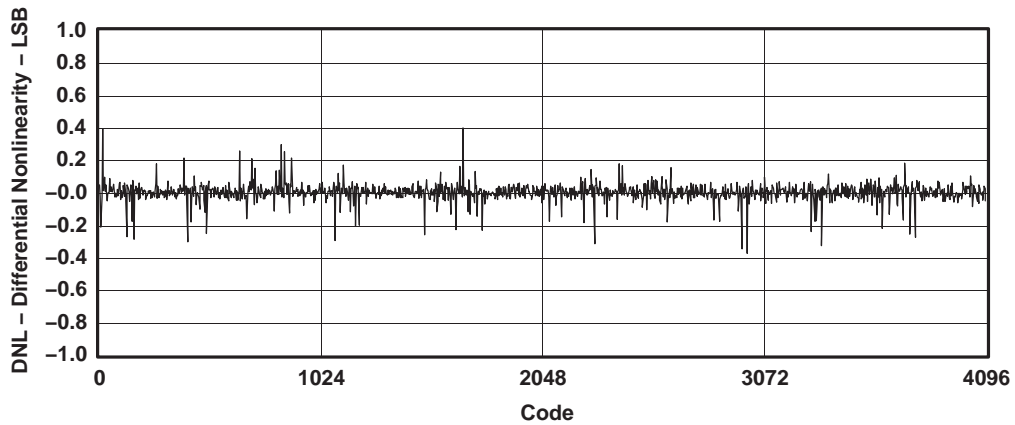

Figure 6

TLV5608IYE
INTEGRAL NONLINEARITY
vs
CODE

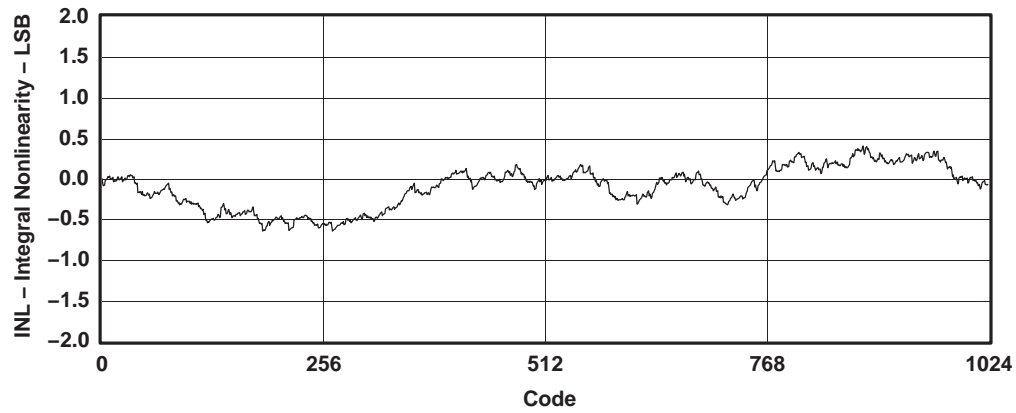

Figure 7

TLV5608IYE
DIFFERENTIAL NONLINEARITY
vs
CODE

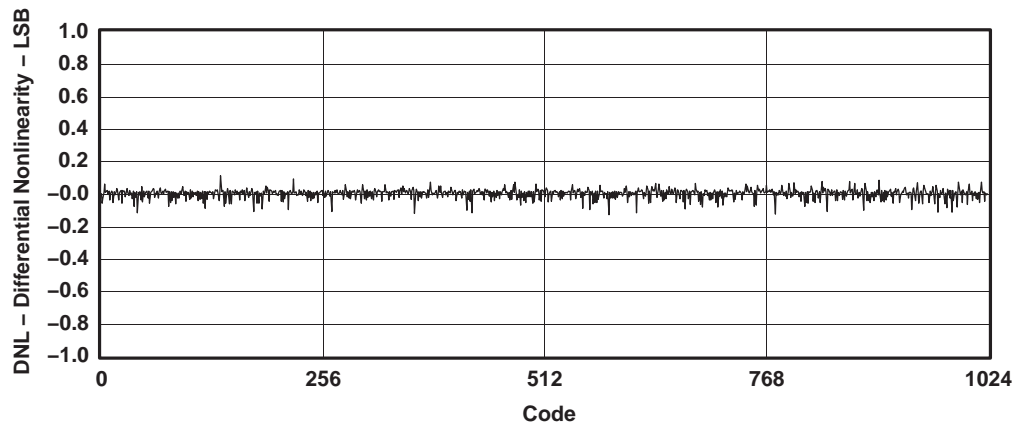

Figure 8

PARAMETER MEASUREMENT INFORMATION

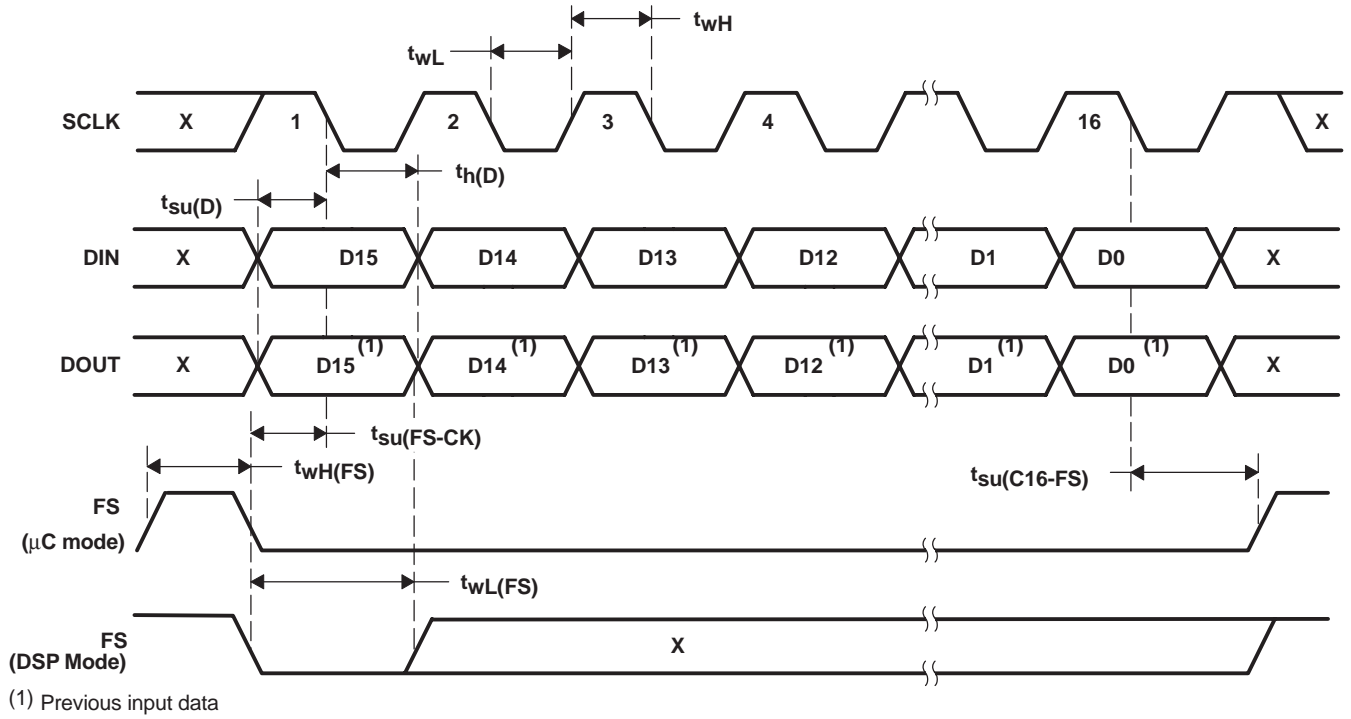

Figure 9. Serial Interface Timing

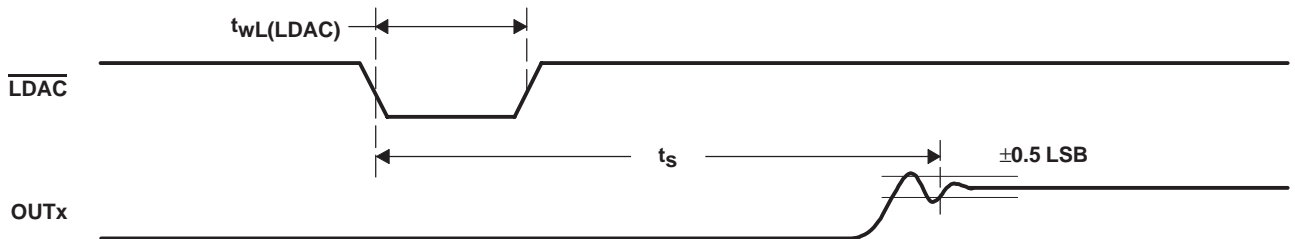

Figure 10. Output Timing

APPLICATION INFORMATION

GENERAL FUNCTION

The TLV5610IYE and TLV5608IYE are 8-channel, 12-bit, single supply DACs, based on a resistor string architecture. They consist of a serial interface, a speed and power-down control logic, a reference input buffer, a resistor string, and a rail-to-rail output buffer.

The output voltage (full scale determined by external reference) for each channel is given by:

$$REF \frac{CODE}{0x1000} [V]$$

where REF is the reference voltage and CODE is the digital input value. The input range is 0x000 to 0xFFE for the TLV5610IYE and, 0x000 to 0xFFC for the TLV5608IYE. A power on reset initially puts the internal latches to a defined state (all bits zero).

SERIAL INTERFACE

A falling edge of FS starts shifting the data on DIN starting with the MSB to the internal register on the falling edges of SCLK. After 16 bits have been transferred, the content of the shift register is moved to one of the DAC holding registers depending on the address bits within the data word. A logic 0 on the \overline{LDAC} pin is required to transfer the content of the DAC holding register to the DAC latch and to update the DAC outputs. \overline{LDAC} is an asynchronous input. It can be held low if a simultaneous update of all eight channels is not needed.

For daisy-chaining, DOUT provides the data sampled on DIN with a delay of 16 clock cycles.

DSP Mode:

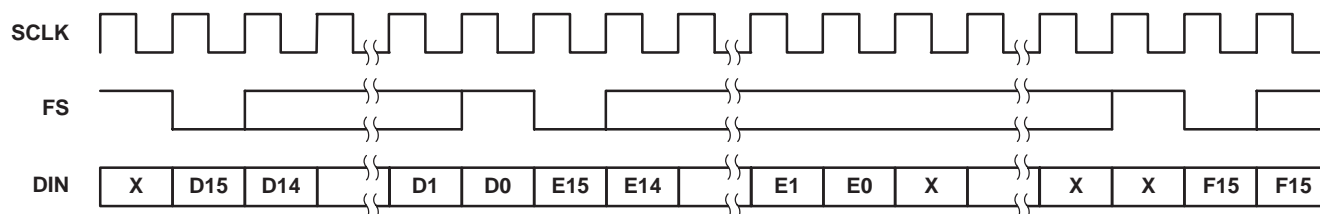

μC Mode:

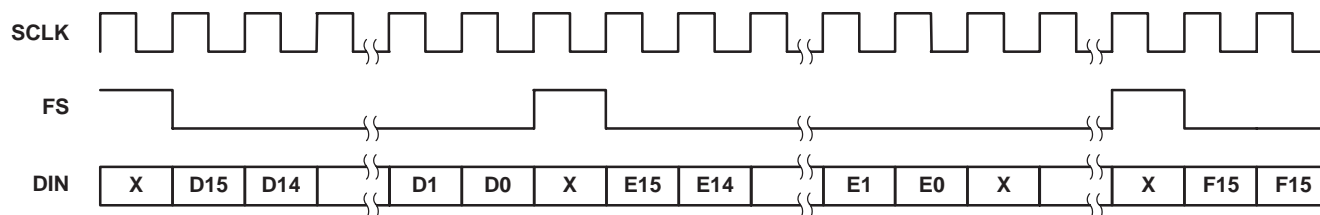

Difference between DSP mode (MODE = N.C. or 0) and μC (MODE = 1) mode:

- In μC mode FS needs to be held low until all 16 data bits have been transferred. If FS is driven high before the 16th falling clock edge the data transfer is cancelled. The DAC is updated after a rising edge on FS.
- In DSP mode FS only needs to stay low for 20 ns and can go high before the 16th falling clock edge.

SERIAL CLOCK FREQUENCY AND UPDATE RATE

The maximum serial clock frequency is given by:

$$f_{\text{sclkmax}} = \frac{1}{t_{\text{whmin}} + t_{\text{wlmin}}} = 30 \text{ MHz}$$

The maximum update rate is:

$$f_{\text{updatemax}} = \frac{1}{16(t_{\text{whmin}} + t_{\text{wlmin}})} = 1.95 \text{ MHz}$$

Note, that the maximum update rate is just a theoretical value for the serial interface, as the settling time of the DAC has to be considered also.

DATA FORMAT

The 16 bit data word consists of two parts:

- Address bits (D15...D12)
- Data bits (D11...D0)

D15	D14	D13	D12	D11	D10	D9	D8	D7	D6	D5	D4	D3	D2	D1	D0
A3	A2	A1	A0	Data											

Ax: Address bits. See table.

REGISTER MAP

A3	A2	A1	A0	FUNCTION
0	0	0	0	DAC A
0	0	0	1	DAC B
0	0	1	0	DAC C
0	0	1	1	DAC D
0	1	0	0	DAC E
0	1	0	1	DAC F
0	1	1	0	DAC G
0	1	1	1	DAC H
1	0	0	0	CTRL0
1	0	0	1	CTRL1
1	0	1	0	Preset
1	0	1	1	Reserved
1	1	0	0	DAC A and \bar{B}
1	1	0	1	DAC C and \bar{D}
1	1	1	0	DAC E and \bar{F}
1	1	1	1	DAC G and \bar{H}

DAC A–H AND TWO-CHANNEL REGISTERS

Writing to DAC A–H sets the output voltage of channel A–H. It is possible to automatically generate the complement of one channel by writing to one of the four two-channel registers (DAC A and \bar{B} etc.).

The TLV5610IYE decodes all 12 data bits. The TLV5608IYE decodes D11 to D2 (D1 and D0 are ignored).

PRESET

The outputs of all DAC channels can be driven to a predefined value stored in the preset register by driving the $\overline{\text{PRE}}$ input low. The $\overline{\text{PRE}}$ input is asynchronous to the clock.

CTRL0

D11	D10	D9	D8	D7	D6	D5	D4	D3	D2	D1	D0
X	X	X	X	X	X	X	PD	DO	X	X	IM

PD : Full device power down 0 = normal 1 = power down
DO : Digital output enable 0 = disable 1 = enable
IM : Input mode 0 = straight binary 1 = twos complement
X : Reserved

If DOUT is enabled, the data input on DIN is output on DOUT with a 16 cycle delay. That makes it possible to daisy-chain multiple DACs on one serial bus.

CTRL1

D11	D10	D9	D8	D7	D6	D5	D4	D3	D2	D1	D0
X	X	X	X	P _{GH}	P _{EF}	P _{CD}	P _{AB}	S _{GH}	S _{EF}	S _{CD}	S _{AB}

P_{XY} : Power Down DAC_{XY} 0 = normal 1 = power down
S_{XY} : Speed DAC_{XY} 0 = slow 1 = fast
XY : DAC pair AB, CD, EF or GH

In power-down mode, the amplifiers of the selected DAC pair within the device are disabled and the total power consumption of the device is significantly reduced. Power-down mode of a specific DAC pair can be selected by setting the PXY bit within the data word to 1.

There are two settling time modes: fast and slow. Fast mode of a DAC pair is selected by setting S_{XY} to 1 and slow mode is selected by setting S_{XY} to 0.

USING TLV5610IYE AND TLV5608IYE, WAFER CHIP SCALE PACKAGE (WCS)

- TLV5610 and TLV5608 qualifications were done using a wire-bonded small outline (SOIC) package and includes: steady state life, thermal shock, ESD, latch-up, biased HAST, autoclave, and characterization. These qualified devices are orderable as TLV5610IDW and TLV5608IDW.
- The wafer chip-scale package (WCS), TLV5610IYE and TLV5608IYE, uses the same DIE as TLV5610IDW and TLV5608IDW respectively, but are not qualified. WCS qualification, including board level reliability (BLR), is the responsibility of the customer.
- It is recommended that underfill be used for increased reliability. BLR is application dependent, but may include test such as: temperature cycling, drop test, key push, bend, vibration, and package shear.

The following WCSP information provides the user of the TLV5610IYE and TLV5608IYE with some general guidelines for board assembly.

- Melting point of eutectic solder is 183°C.
- Recommended peak reflow temperatures are in the 220°C to 230°C range.
- The use of underfill is required. The use of underfill greatly reduces the risk of thermal mismatch fails.

Underfill is an epoxy/adhesive that may be added during the board assembly process to improve board level/system level reliability. The process is to dispense the epoxy under the dice after die attach reflow. The epoxy adheres to the body of the device and to the printed-circuit board. It reduces stress placed upon the solder joints due to the thermal coefficient of expansion (TCE) mismatch between the board and the component. Underfill material is highly filled with silica or other fillers to increase an epoxy's modulus, reduce creep sensitivity, and decrease the material's TCE.

The recommendation for peak flow temperatures of 220°C to 230°C is based on general empirical results that indicate that this temperature range is needed to facilitate good wetting of the solder bump to the substrate or circuit board pad. Lower peak temperatures may cause nonwets (cold solder joints).

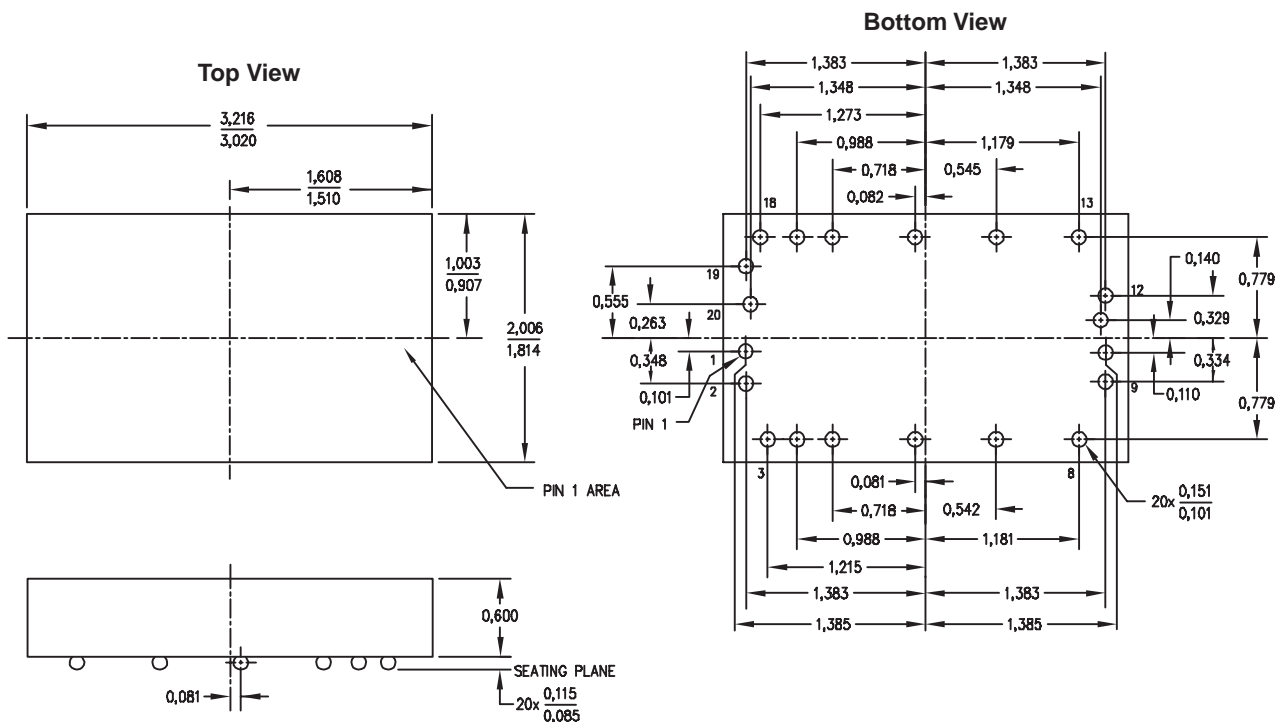

- NOTES: A. All linear dimensions are in millimeters.
B. This drawing is subject to change without notice.

Figure 11. TLV5610IYE and TLV5608IYE Wafer Chip Scale Package

PACKAGING INFORMATION

Orderable Device	Status (1)	Package Type	Package Drawing	Pins	Package Qty	Eco Plan (2)	Lead/Ball Finish (6)	MSL Peak Temp (3)	Op Temp (°C)	Device Marking (4/5)	Samples
TLV5608IYER	OBSOLETE	DIESALE	YE	20		TBD	Call TI	Call TI	-40 to 85		
TLV5610IYE	ACTIVE	DIESALE	YE	20	150	TBD	SNAGCU	N / A for Pkg Type	-40 to 85	TLV5610YE	Samples

(1) The marketing status values are defined as follows:

ACTIVE: Product device recommended for new designs.

LIFEBUY: TI has announced that the device will be discontinued, and a lifetime-buy period is in effect.

NRND: Not recommended for new designs. Device is in production to support existing customers, but TI does not recommend using this part in a new design.

PREVIEW: Device has been announced but is not in production. Samples may or may not be available.

OBSOLETE: TI has discontinued the production of the device.

(2) Eco Plan - The planned eco-friendly classification: Pb-Free (RoHS), Pb-Free (RoHS Exempt), or Green (RoHS & no Sb/Br) - please check <http://www.ti.com/productcontent> for the latest availability information and additional product content details.

TBD: The Pb-Free/Green conversion plan has not been defined.

Pb-Free (RoHS): TI's terms "Lead-Free" or "Pb-Free" mean semiconductor products that are compatible with the current RoHS requirements for all 6 substances, including the requirement that lead not exceed 0.1% by weight in homogeneous materials. Where designed to be soldered at high temperatures, TI Pb-Free products are suitable for use in specified lead-free processes.

Pb-Free (RoHS Exempt): This component has a RoHS exemption for either 1) lead-based flip-chip solder bumps used between the die and package, or 2) lead-based die adhesive used between the die and leadframe. The component is otherwise considered Pb-Free (RoHS compatible) as defined above.

Green (RoHS & no Sb/Br): TI defines "Green" to mean Pb-Free (RoHS compatible), and free of Bromine (Br) and Antimony (Sb) based flame retardants (Br or Sb do not exceed 0.1% by weight in homogeneous material)

(3) MSL, Peak Temp. - The Moisture Sensitivity Level rating according to the JEDEC industry standard classifications, and peak solder temperature.

(4) There may be additional marking, which relates to the logo, the lot trace code information, or the environmental category on the device.

(5) Multiple Device Markings will be inside parentheses. Only one Device Marking contained in parentheses and separated by a "~" will appear on a device. If a line is indented then it is a continuation of the previous line and the two combined represent the entire Device Marking for that device.

(6) Lead/Ball Finish - Orderable Devices may have multiple material finish options. Finish options are separated by a vertical ruled line. Lead/Ball Finish values may wrap to two lines if the finish value exceeds the maximum column width.

Important Information and Disclaimer: The information provided on this page represents TI's knowledge and belief as of the date that it is provided. TI bases its knowledge and belief on information provided by third parties, and makes no representation or warranty as to the accuracy of such information. Efforts are underway to better integrate information from third parties. TI has taken and continues to take reasonable steps to provide representative and accurate information but may not have conducted destructive testing or chemical analysis on incoming materials and chemicals. TI and TI suppliers consider certain information to be proprietary, and thus CAS numbers and other limited information may not be available for release.

In no event shall TI's liability arising out of such information exceed the total purchase price of the TI part(s) at issue in this document sold by TI to Customer on an annual basis.

IMPORTANT NOTICE

Texas Instruments Incorporated and its subsidiaries (TI) reserve the right to make corrections, enhancements, improvements and other changes to its semiconductor products and services per JESD46, latest issue, and to discontinue any product or service per JESD48, latest issue. Buyers should obtain the latest relevant information before placing orders and should verify that such information is current and complete. All semiconductor products (also referred to herein as "components") are sold subject to TI's terms and conditions of sale supplied at the time of order acknowledgment.

TI warrants performance of its components to the specifications applicable at the time of sale, in accordance with the warranty in TI's terms and conditions of sale of semiconductor products. Testing and other quality control techniques are used to the extent TI deems necessary to support this warranty. Except where mandated by applicable law, testing of all parameters of each component is not necessarily performed.

TI assumes no liability for applications assistance or the design of Buyers' products. Buyers are responsible for their products and applications using TI components. To minimize the risks associated with Buyers' products and applications, Buyers should provide adequate design and operating safeguards.

TI does not warrant or represent that any license, either express or implied, is granted under any patent right, copyright, mask work right, or other intellectual property right relating to any combination, machine, or process in which TI components or services are used. Information published by TI regarding third-party products or services does not constitute a license to use such products or services or a warranty or endorsement thereof. Use of such information may require a license from a third party under the patents or other intellectual property of the third party, or a license from TI under the patents or other intellectual property of TI.

Reproduction of significant portions of TI information in TI data books or data sheets is permissible only if reproduction is without alteration and is accompanied by all associated warranties, conditions, limitations, and notices. TI is not responsible or liable for such altered documentation. Information of third parties may be subject to additional restrictions.

Resale of TI components or services with statements different from or beyond the parameters stated by TI for that component or service voids all express and any implied warranties for the associated TI component or service and is an unfair and deceptive business practice. TI is not responsible or liable for any such statements.

Buyer acknowledges and agrees that it is solely responsible for compliance with all legal, regulatory and safety-related requirements concerning its products, and any use of TI components in its applications, notwithstanding any applications-related information or support that may be provided by TI. Buyer represents and agrees that it has all the necessary expertise to create and implement safeguards which anticipate dangerous consequences of failures, monitor failures and their consequences, lessen the likelihood of failures that might cause harm and take appropriate remedial actions. Buyer will fully indemnify TI and its representatives against any damages arising out of the use of any TI components in safety-critical applications.

In some cases, TI components may be promoted specifically to facilitate safety-related applications. With such components, TI's goal is to help enable customers to design and create their own end-product solutions that meet applicable functional safety standards and requirements. Nonetheless, such components are subject to these terms.

No TI components are authorized for use in FDA Class III (or similar life-critical medical equipment) unless authorized officers of the parties have executed a special agreement specifically governing such use.

Only those TI components which TI has specifically designated as military grade or "enhanced plastic" are designed and intended for use in military/aerospace applications or environments. Buyer acknowledges and agrees that any military or aerospace use of TI components which have **not** been so designated is solely at the Buyer's risk, and that Buyer is solely responsible for compliance with all legal and regulatory requirements in connection with such use.

TI has specifically designated certain components as meeting ISO/TS16949 requirements, mainly for automotive use. In any case of use of non-designated products, TI will not be responsible for any failure to meet ISO/TS16949.

Products

Audio	www.ti.com/audio
Amplifiers	amplifier.ti.com
Data Converters	dataconverter.ti.com
DLP® Products	www.dlp.com
DSP	dsp.ti.com
Clocks and Timers	www.ti.com/clocks
Interface	interface.ti.com
Logic	logic.ti.com
Power Mgmt	power.ti.com
Microcontrollers	microcontroller.ti.com
RFID	www.ti-rfid.com
OMAP Applications Processors	www.ti.com/omap
Wireless Connectivity	www.ti.com/wirelessconnectivity

Applications

Automotive and Transportation	www.ti.com/automotive
Communications and Telecom	www.ti.com/communications
Computers and Peripherals	www.ti.com/computers
Consumer Electronics	www.ti.com/consumer-apps
Energy and Lighting	www.ti.com/energy
Industrial	www.ti.com/industrial
Medical	www.ti.com/medical
Security	www.ti.com/security
Space, Avionics and Defense	www.ti.com/space-avionics-defense
Video and Imaging	www.ti.com/video

TI E2E Community

e2e.ti.com