

MSP430C32x, MSP430P325A MIXED SIGNAL MICROCONTROLLER

SLAS219B – MARCH 1999 – REVISED MARCH 2000

- Low Supply Voltage Range, 2.5 V – 5.5 V
- Low Operation Current, 400 μ A at 1 MHz, 3 V
- Ultra-Low Power Consumption (Standby Mode Down to 0.1 μ A)
- Five Power-Saving Modes
- Wakeup From Standby Mode in 6 μ s
- 16-Bit RISC Architecture, 300 ns Instruction Cycle Time
- Single Common 32 kHz Crystal, Internal System Clock up to 3.3 MHz
- Integrated LCD Driver for up to 84 Segments
- Integrated 12+2 Bit A/D Converter
- Family Members Include:
 - MSP430C323, 8KB ROM, 256 Byte RAM
 - MSP430C325, 16KB ROM, 512 Byte RAM
 - MSP430P325A, 16KB OTP, 512 Byte RAM
- EPROM Version Available for Prototyping: PMS430E325A
- Serial Onboard Programming
- Programmable Code Protection by Security Fuse
- Available in 64 Pin Quad Flatpack (QFP), 68 Pin Plastic J-Leaded Chip Carrier (PLCC), 68 Pin J-Leaded Ceramic Chip Carrier (JLCC) Package (EPROM Version)

description

The Texas Instruments MSP430 is an ultra-low power mixed-signal microcontroller family consisting of several devices which feature different sets of modules targeted to various applications. The microcontroller is designed to be battery operated for an extended application lifetime. With 16-bit RISC architecture, 16-bit integrated registers on the CPU, and a constant generator, the MSP430 achieves maximum code efficiency. The digitally-controlled oscillator, together with the frequency-locked-loop (FLL), provides a wakeup from a low-power mode to active mode in less than 6 μ s.

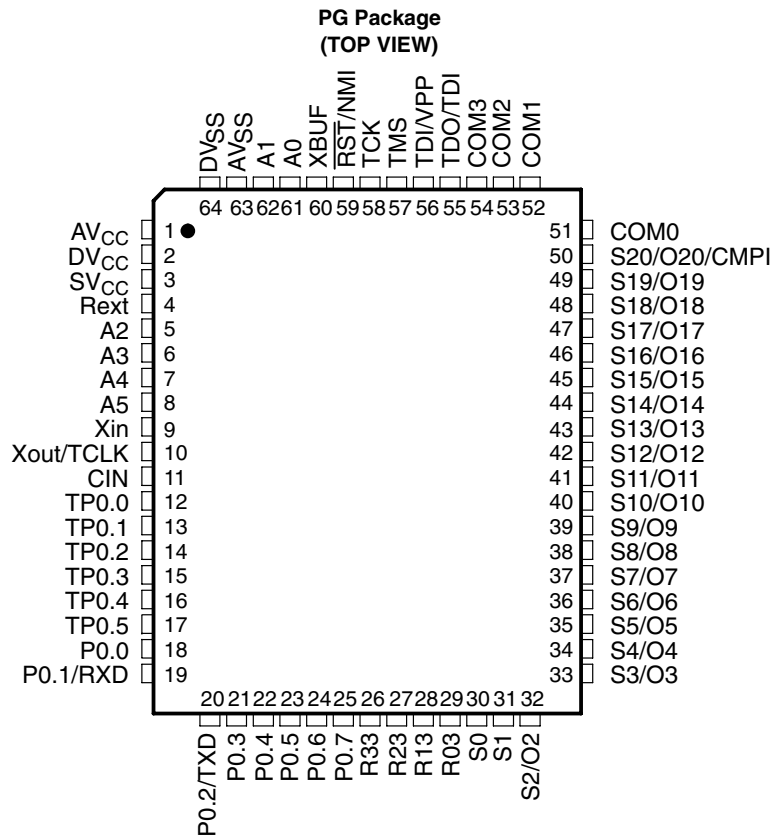

Please be aware that an important notice concerning availability, standard warranty, and use in critical applications of Texas Instruments semiconductor products and disclaimers thereto appears at the end of this data sheet.

PRODUCTION DATA information is current as of publication date. Products conform to specifications per the terms of Texas Instruments standard warranty. Production processing does not necessarily include testing of all parameters.

**TEXAS
INSTRUMENTS**

POST OFFICE BOX 655303 • DALLAS, TEXAS 75265
POST OFFICE BOX 1443 • HOUSTON, TEXAS 77251-1443

Copyright © 2000, Texas Instruments Incorporated

MSP430C32x, MSP430P325A MIXED SIGNAL MICROCONTROLLER

SLAS219B – MARCH 1999 – REVISED MARCH 2000

description (continued)

Typical applications include sensor systems that capture analog signals, convert them to digital values, and then process the data and display them or transmit them to a host system. The MSP430x32x offers an integrated 12+2 bit A/D converter with six multiplexed inputs.

AVAILABLE OPTIONS

T _A	PACKAGED DEVICES			
	PLASTIC 64-PIN QFP (PG)	PLASTIC 64-PIN QFP (PM)	PLASTIC 68-PIN PLCC (FN)	CERAMIC 68-PIN JLCC (FZ)
-40°C to 85°C	MSP430C323IPG MSP430C325IPG MSP430P325AIPG	MSP430C323IPM MSP430C325IPM MSP430P325AIPM	MSP430C323IFN MSP430C325IFN MSP430P325AIFN	—
25°C	—	—	—	PMS430E325AFZ

functional block diagram

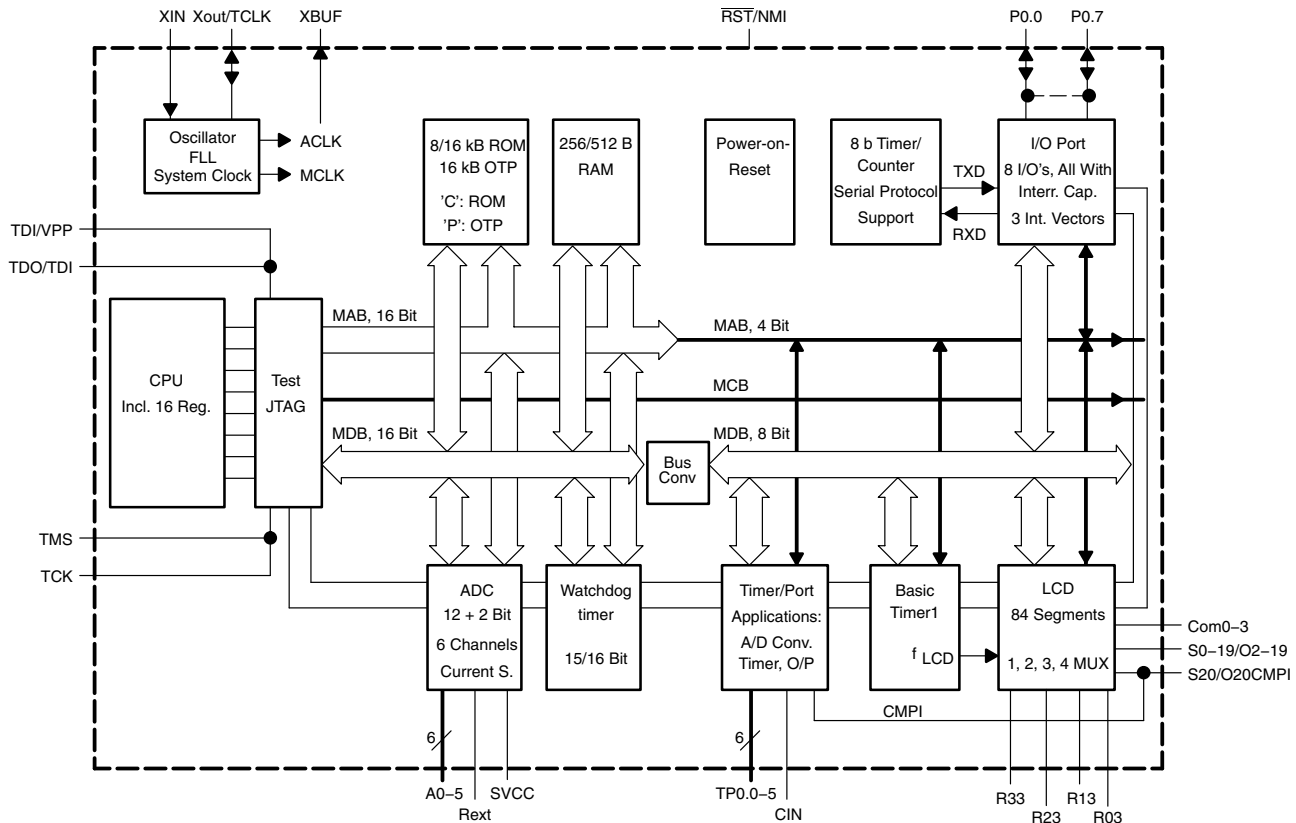

Terminal Functions

TERMINAL NAME	NO.	I/O	DESCRIPTION
AV _{CC}	1		Positive analog supply voltage
AV _{SS}	63		Analog ground reference
A0	61	I	Analog-to-digital converter input port 0 or digital input port 0
A1	62	I	Analog-to-digital converter input port 1 or digital input port 1
A2–A5	5–8	I	Analog-to-digital converter inputs ports 2–5 or digital inputs ports 2–5
CIN	11	I	Input used as enable of counter TPCNT1 – Timer/Port
COM0–3	51–54	O	Common outputs, used for LCD backplanes – LCD
DV _{CC}	2		Positive digital supply voltage
DV _{SS}	64		Digital ground reference
P0.0	18	I/O	General-purpose digital I/O
P0.1/RXD	19	I/O	General-purpose digital I/O, receive digital input port, 8-bit Timer/Counter
P0.2/TXD	20	I/O	General-purpose digital I/O, transmit data output port, 8-bit Timer/Counter
P0.3–P0.7	21–25	I/O	Five general-purpose digital I/Os, bit 3 to bit 7
Rext	4	I	Programming resistor input of internal current source
RST/NMI	59	I	Reset input or non-maskable interrupt input
R03	29	I	Input of fourth positive analog LCD level (V4) – LCD
R13	28	I	Input of third positive analog LCD level (V3) – LCD
R23	27	I	Input of second positive analog LCD level (V2) – LCD
R33	26	O	Output of first positive analog LCD level (V1) – LCD
SV _{CC}	3		Switched AV _{CC} to analog-to-digital converter
S0	30	O	Segment line S0 – LCD
S1	31	O	Segment line S1 – LCD
S2–S5/O2–O5	32–35	O	Segment lines S2 to S5 or digital output ports O2–O5, group 1 – LCD
S20/O20/CMPI	50	I/O	Segment line S20 can be used as comparator input port CMPI – Timer/Port
S6–S9/O6–O9	36–39	O	Segment lines S6 to S9 or digital output ports O6–O9, group 2 – LCD
S10–S13/O10–O13	40–43	O	Segment lines S10 to S13 or digital output ports O10–O13, group 3 – LCD
S14–S17/O14–O17	44–47	O	Segment lines S14 to S17 or digital output ports O14 to O17, group 4 – LCD
S18–S19/O18–O19	48, 49	O	Segment lines S18 and S19 or digital output port O18 and O19, group 5 – LCD
TCK	58	I	Test clock, clock input terminal for device programming and test
TDO/TDI	55	I/O	Test data output, data output terminal or data input during programming
TDI/VPP	56	I	Test data input, data input terminal or input of programming voltage
TMS	57	I	Test mode select, input terminal for device programming and test
TP0.0	12	O	General-purpose 3-state digital output port, bit 0 – Timer/Port
TP0.1	13	O	General-purpose 3-state digital output port, bit 1 – Timer/Port
TP0.2	14	O	General-purpose 3-state digital output port, bit 2 – Timer/Port
TP0.3	15	O	General-purpose 3-state digital output port, bit 3 – Timer/Port
TP0.4	16	O	General-purpose 3-state digital output port, bit 4 – Timer/Port
TP0.5	17	I/O	General-purpose digital input/output port, bit 5 – Timer/Port
XBUF	60	O	Clock signal output of system clock MCLK or crystal clock ACLK
Xin	9	I	Input terminal of crystal oscillator
Xout/TCLK	10	I/O	Output terminal of crystal oscillator or test clock input

MSP430C32x, MSP430P325A MIXED SIGNAL MICROCONTROLLER

SLAS219B – MARCH 1999 – REVISED MARCH 2000

short-form description

processing unit

The processing unit is based on a consistent and orthogonally-designed CPU and instruction set. This design structure results in a RISC-like architecture, highly transparent to the application development and is distinguished due to ease of programming. All operations other than program-flow instructions are consequently performed as register operations in conjunction with seven addressing modes for source and four modes for destination operand.

CPU

Sixteen registers are located inside the CPU, providing reduced instruction execution time. This reduces a register-register operation execution time to one cycle of the processor frequency.

Four of the registers are reserved for special use as a program counter, a stack pointer, a status register and a constant generator. The remaining registers are available as general-purpose registers.

Peripherals are connected to the CPU using a data address and control bus and can be handled easily with all instructions for memory manipulation.

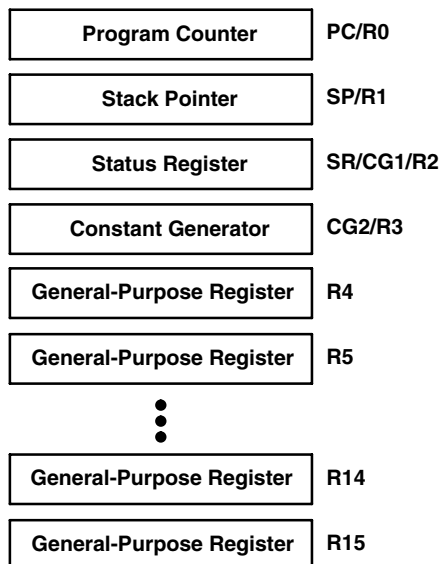

instruction set

The instruction set for this register-register architecture provides a powerful and easy-to-use assembler language. The instruction set consists of 51 instructions with three formats and seven addressing modes. Table 1 provides a summation and example of the three types of instruction formats; the addressing modes are listed in Table 2.

Table 1. Instruction Word Formats

Dual operands, source-destination	e.g. ADD R4, R5	R4 + R5 → R5
Single operands, destination only	e.g. CALL R8	PC → (TOS), R8 → PC
Relative jump, un-/conditional	e.g. JNE	Jump-on equal bit = 0

Each instruction that operates on word and byte data is identified by the suffix B.

Examples:	Instructions for word operation	Instructions for byte operation
	MOV EDE, TONI	MOV.B EDE, TONI
	ADD #235h, &MEM	ADD.B #35h, &MEM
	PUSH R5	PUSH.B R5
	SWPB R5	—



Table 2. Address Mode Descriptions

ADDRESS MODE	s	d	SYNTAX	EXAMPLE	OPERATION
Register	√	√	MOV Rs, Rd	MOV R10, R11	R10 → R11
Indexed	√	√	MOV X(Rn), Y(Rm)	MOV 2(R5), 5(R6)	M(2 + R5) → M(6 + R6)
Symbolic (PC relative)	√	√	MOV EDE, TONI		M(EDE) → M(TONI)
Absolute	√	√	MOV &MEM, &TCDAT		M(MEM) → M(TCDAT)
Indirect	√		MOV @Rn, Y(Rm)	MOV @R10, Tab(R6)	M(R10) → M(Tab + R6)
Indirect autoincrement	√		MOV @Rn+, RM	MOV @R10+, R11	M(R10) → R11, R10 + 2 → R10
Immediate	√		MOV #X, TONI	MOV #45, TONI	#45 → M(TONI)

NOTE: s = source d = destination

Computed branches (BR) and subroutine calls (CALL) instructions use the same addressing modes as the other instructions. These addressing modes provide *indirect* addressing, ideally suited for computed branches and calls. The full use of this programming capability permits a program structure different from conventional 8- and 16-bit controllers. For example, numerous routines can easily be designed to deal with pointers and stacks instead of using flag type programs for flow control.

operation modes and interrupts

The MSP430 operating modes support various advanced requirements for ultra low power and ultra low energy consumption. This is achieved by the intelligent management of the operations during the different module operation modes and CPU states. The requirements are fully supported during interrupt event handling. An interrupt event awakens the system from each of the various operating modes and returns with the RETI instruction to the mode that was selected before the interrupt event. The clocks used are ACLK and MCLK. ACLK is the crystal frequency and MCLK is a multiple of ACLK and is used as the system clock.

The software can configure five operating modes:

- Active mode (AM). The CPU is enabled with different combinations of active peripheral modules.
- Low power mode 0 (LPM0). The CPU is disabled, peripheral operation continues, ACLK and MCLK signals are active, and loop control for MCLK is active.
- Low power mode 1 (LPM1). The CPU is disabled, peripheral operation continues, ACLK and MCLK signals are active, and loop control for MCLK is inactive.
- Low power mode 2 (LPM2). The CPU is disabled, peripheral operation continues, ACLK signal is active, and MCLK and loop control for MCLK are inactive.
- Low power mode 3 (LPM3). The CPU is disabled, peripheral operation continues, ACLK signal is active, MCLK and loop control for MCLK are inactive, and the dc generator for the digital controlled oscillator (DCO) (→MCLK generator) is switched off.
- Low power mode 4 (LPM4). The CPU is disabled, peripheral operation continues, ACLK signal is inactive (crystal oscillator stopped), MCLK and loop control for MCLK are inactive, and the dc generator for the DCO is switched off.

The special function registers (SFR) include module-enable bits that stop or enable the operation of the specific peripheral module. All registers of the peripherals may be accessed if the operational function is stopped or enabled. However, some peripheral current-saving functions are accessed through the state of local register bits. An example is the enable/disable of the analog voltage generator in the LCD peripheral, which is turned on or off using one register bit.



MSP430C32x, MSP430P325A MIXED SIGNAL MICROCONTROLLER

SLAS219B – MARCH 1999 – REVISED MARCH 2000

operation modes and interrupts (continued)

The most general bits that influence current consumption and support fast turnon from low-power operating modes are located in the status register (SR). Four of these bits control the CPU and the system clock generator: SCG1, SCG0, OscOff, and CPUOff.

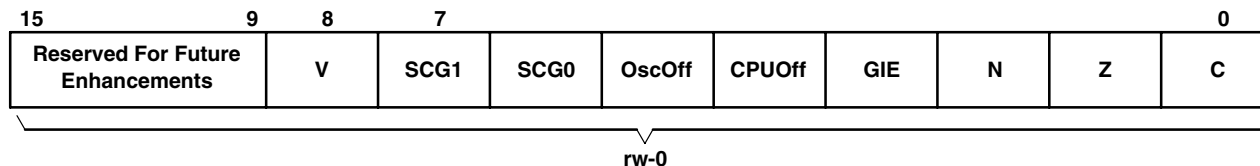

interrupt vector addresses

The interrupt vectors and the power-up starting address are located in the ROM with an address range of 0FFFFh-0FFE0h. The vector contains the 16-bit address of the appropriate interrupt handler instruction sequence.

INTERRUPT SOURCE	INTERRUPT FLAG	SYSTEM INTERRUPT	WORD ADDRESS	PRIORITY
Power-up, external reset, watchdog	WDTIFG (see Note 1)	Reset	0FFFEh	15, highest
NMI, oscillator fault	NMIIFG (see Notes 1 and 3) OFIFG (see Notes 1 and 4)	Non-maskable, (Non)-maskable	0FFFCh	14
Dedicated I/O P0.0	P0.0IFG	maskable	0FFFAh	13
Dedicated I/O P0.1 or 8-bit Timer/Counter RXD	P0.1IFG	maskable	0FFF8h	12
			0FFF6h	11
Watchdog Timer	WDTIFG	maskable	0FFF4h	10
			0FFF2h	9
			0FFF0h	8
			0FFEEh	7
			0FFEC	6
ADC	ADCIFG	maskable	0FFEAh	5
Timer/Port	RC1FG, RC2FG, EN1FG (see Note 2)	maskable	0FFE8h	4
			0FFE6h	3
			0FFE4h	2
Basic Timer1	BTIFG	maskable	0FFE2h	1
I/O port 0, P0.2–7	P0.27IFG (see Note 1)	maskable	0FFE0h	0, lowest

NOTE 1: Multiple source flags

NOTE 2: Timer/Port interrupt flags are located in the T/P registers

NOTE 3: Non-maskable: neither the individual nor the general interrupt enable bit will disable an interrupt event.

NOTE 4: (Non)-maskable: the individual interrupt enable bit can disable on interrupt event, but the general interrupt enable bit cannot.



operation modes and interrupts (continued)

special function registers

Most interrupt and module enable bits are collected into the lowest address space. Special function register bits that are not allocated to a functional purpose are not physically present in the device. Simple SW access is provided with this arrangement.

interrupt enable 1 and 2

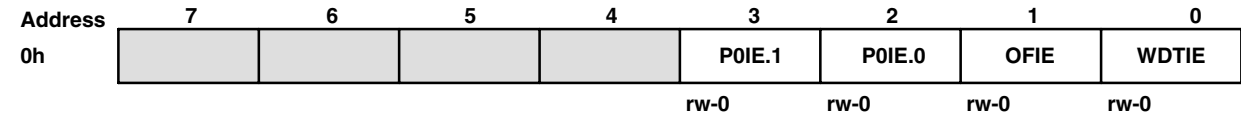

WDTIE: Watchdog Timer enable signal
 OFIE: Oscillator fault enable signal
 P0IE.0: Dedicated I/O P0.0
 P0IE.1: P0.1 or 8-bit Timer/Counter, RXD

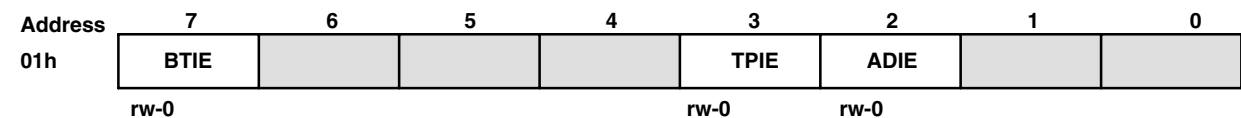

ADIE: A/D converter enable signal
 TPIE: Timer/Port enable signal
 BTIE: Basic Timer1 enable signal

interrupt flag register 1 and 2

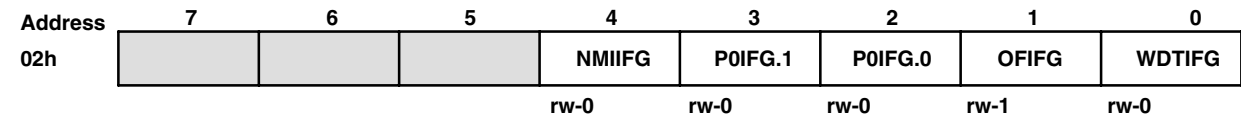

WDTIFG: Set on overflow or security key violation
 or
 Reset on V_{CC} power on or reset condition at \overline{RST}/NMI -pin
 OFIFG: Flag set on oscillator fault
 P0.0IFG: Dedicated I/O P0.0
 P0.1IFG: P0.1 or 8-bit Timer/Counter, RXD
 NMIIFG: Signal at \overline{RST}/NMI -pin

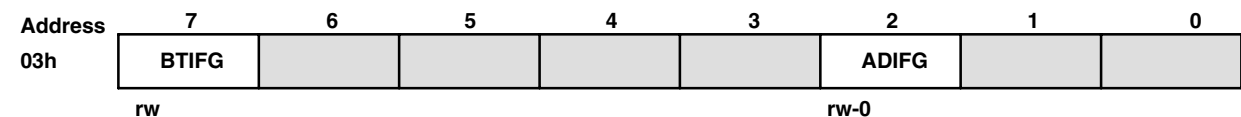

BTIFG: Basic Timer1 flag
 ADIFG: Analog-to-digital converter flag

MSP430C32x, MSP430P325A MIXED SIGNAL MICROCONTROLLER

SLAS219B – MARCH 1999 – REVISED MARCH 2000

operation modes and interrupts (continued)

module enable register 1 and 2

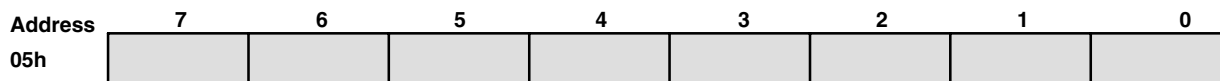
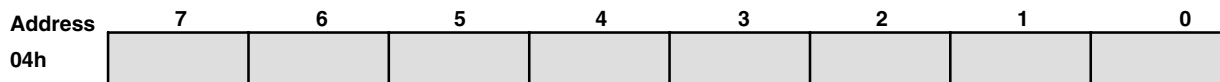

Legend **rw:** Bit can be read and written.
rw-0: Bit can be read and written. It is reset by PUC.
 SFR bit not present in device.

memory organization

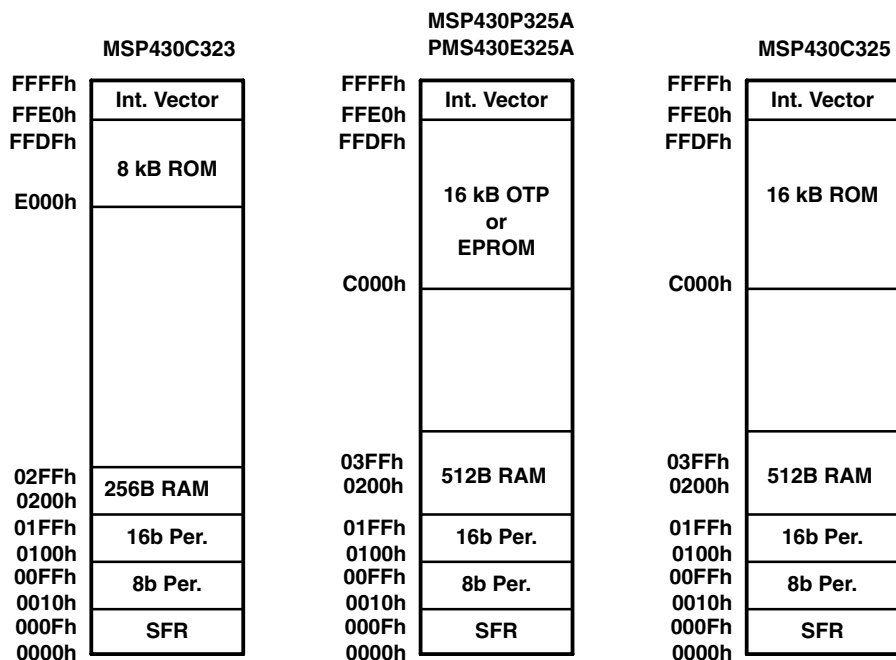

peripherals

Peripherals connect to the CPU through data, address, and control busses and can be handled easily with all instructions for memory manipulation.

peripheral file map

PERIPHERALS WITH WORD ACCESS			
Watchdog	Watchdog Timer control	WDTCTL	0120h
ADC	Data register	ADAT	0118h
	Reserved		0116h
	Control register	ACTL	0114h
	Input enable register	AEN	0112h
	Input register	AIN	0110h
PERIPHERALS WITH BYTE ACCESS			
EPROM	EPROM control	EPCTL	054h
Crystal buffer	Crystal buffer control	CBCTL	053h
System clock	SCG frequency control	SCFQCTL	052h
	SCG frequency integrator	SCFI1	051h
	SCG frequency integrator	SCFI0	050h
Timer/Port	Timer/Port enable	TPE	04Fh
	Timer/Port data	TPD	04Eh
	Timer/Port counter2	TPCNT2	04Dh
	Timer/Port counter1	TPCNT1	04Ch
	Timer/Port control	TPCTL	04Bh
8-Bit Timer/Counter	8-Bit Timer/Counter data	TCDAT	044h
	8-Bit Timer/Counter preload	TCPLD	043h
	8-Bit Timer/Counter control	TCCTL	042h
Basic Timer1	Basic Timer counter2	BTCNT2	047h
	Basic Timer counter1	BTCNT1	046h
	Basic Timer control	BTCTL	040h
LCD	LCD memory 15	LCDM15	03Fh
	:	:	:
	LCD memory 1	LCDM1	031h
	LCD control & mode	LCDCTL	030h
Port P0	Port P0 interrupt enable	P0IE	015h
	Port P0 interrupt edge select	P0IES	014h
	Port P0 interrupt flag	P0IFG	013h
	Port P0 direction	P0DIR	012h
	Port P0 output	P0OUT	011h
	Port P0 input	P0IN	010h
Special function	SFR interrupt flag2	IFG2	003h
	SFR interrupt flag1	IFG1	002h
	SFR interrupt enable2	IE2	001h
	SFR interrupt enable1	IE1	000h

oscillator and system clock

Two clocks are used in the system, the system (master) clock (MCLK) and the auxiliary clock (ACLK). The MCLK is a multiple of the ACLK. The ACLK runs with the crystal oscillator frequency. The special design of the oscillator supports the feature of low current consumption and the use of a 32 768 Hz crystal. The crystal is connected across two terminals without any other external components being required.

The oscillator starts after applying VCC, due to a reset of the control bit (OscOff) in the status register (SR). It can be stopped by setting the OscOff bit to a 1. The enabled clock signals ACLK, ACLK/2, ACLK/4, or MCLK are accessible for use by external devices at output terminal XBUF.



MSP430C32x, MSP430P325A MIXED SIGNAL MICROCONTROLLER

SLAS219B – MARCH 1999 – REVISED MARCH 2000

oscillator and system clock (continued)

The controller system clock has to operate with different requirements according to the application and system conditions. Requirements include:

- High frequency in order to react quickly to system hardware requests or events
- Low frequency in order to minimize current consumption, EMI, etc.
- Stable frequency for timer applications e.g. real time clock (RTC)
- Enable start-stop operation with a minimum of delay

These requirements cannot all be met with fast frequency high-Q crystals or with RC-type low-Q oscillators. The compromise selected for the MSP430 uses a low-crystal frequency which is multiplied to achieve the desired nominal operating range:

$$f_{(\text{system})} = (N+1) \times f_{(\text{crystal})}$$

The crystal frequency multiplication is achieved with a frequency locked loop (FLL) technique. The factor N is set to 31 after a power-up clear condition. The FLL technique, in combination with a digital controlled oscillator (DCO) provides immediate start-up capability together with long term crystal stability. The frequency variation of the DCO with the FLL inactive is typically 330 ppm which means that with a cycle time of 1 μ s the maximum possible variation is 0.33 ns. For more precise timing, the FLL can be used which forces longer cycle times if the previous cycle time was shorter than the selected one. This switching of cycle times makes it possible to meet the chosen system frequency over a long period of time.

The start-up operation of the system clock depends on the previous machine state. During a power up clear (PUC), the DCO is reset to its lowest possible frequency. The control logic starts operation immediately after recognition of PUC. Connect operation of the FLL control logic requires the presence of a stable crystal oscillator.

digital I/O

One 8-bit I/O port (Port0) is implemented. Six control registers give maximum flexibility of digital input/output to the application:

- All individual I/O bits are programmable independently.
- Any combination of input, output, and interrupt conditions is possible.
- Interrupt processing of external events is fully implemented for all eight bits of port P0.
- Provides read/write access to all registers with all instructions.

The six registers are:

- Input register Contains information at the pins
- Output register Contains output information
- Direction register Controls direction
- Interrupt flags Indicates if interrupt(s) are pending
- Interrupt edge select Contains input signal change necessary for interrupt
- Interrupt enable Contains interrupt enable pins

All six registers contain eight bits except for the interrupt flag register and the interrupt enable register. The two LSBs of the interrupt flag and interrupt enable registers are located in the special functions register (SFR). Three interrupt vectors are implemented, one for Port0.0, one for Port0.1, and one commonly used for any interrupt event on Port0.2 to Port0.7. The Port0.1 and Port0.2 pin function is shared with the 8-bit Timer/Counter.

LCD drive

Liquid crystal displays (LCDs) for static, 2-, 3- and 4-MUX operations can be driven directly. The controller LCD logic operation is defined by software using memory-bit manipulation. LCD memory is part of the LCD module, not part of data memory. Eight mode and control bits define the operation and current consumption of the LCD drive. The information for the individual digits can be easily obtained using table programming techniques combined with the correct addressing mode. The segment information is stored in LCD memory using instructions for memory manipulation.

The drive capability is mainly defined by the external resistor divider that supports the analog levels for 2-, 3- and 4-MUX operation. Groups of the LCD segment lines can be selected for digital output signals. The MSP430x32x configuration has four common signal lines and 21 segment lines.

A/D converter

The analog-to-digital converter (ADC) is a cascaded converter type that converts analog signals from V_{CC} to GND. It is a 12+2 bit converter with a software or automatically-controlled range select. Five inputs can be selected for analog or digital function. A ratiometric current source can be used on four of the analog pins. The current is adjusted by an external resistor and is enabled/disabled by bits located in the control registers. The conversion is started by setting the start-of-conversion bit (SOC) in the control register and the end-of-conversions sets the interrupt flag. The analog input signal is sampled starting with SOC during the next twelve MCLK clock pulses. The power-down bit in the control register controls the operating mode of the ADC peripheral. The current consumption and operation is stopped when it is set. The system reset PUC sets the power-down bit.

Basic Timer1

The Basic Timer1 (BT1) divides the frequency of MCLK or ACLK, as selected with the SSEL bit, to provide low frequency control signals. This is done within the system by one central divider, the Basic Timer1, to support low current applications. The BTCTL control register contains the flags which controls or selects the different operational functions. When the supply voltage is applied or when a reset of the device (\overline{RST}/NMI pin), a watchdog overflow, or a watchdog security key violation occurs, all bits in the register hold undefined or unchanged status. The user software usually configures the operational conditions on the BT1 during initialization.

The Basic Timer1 has two 8-bit timers which can be cascaded to a 16-bit timer. Both timers can be read and written by software. Two bits in the SFR address range handle the system control interaction according to the function implemented in the Basic Timer1. These two bits are the Basic Timer1 interrupt flag (BTIFG) and the Basic Timer1 interrupt enable (BTIE) bit.

Watchdog Timer

The primary function of the Watchdog Timer (WDT) module is to perform a controlled system restart after a software upset has occurred. If the selected time interval expires, a system reset is generated. If this watchdog function is not needed in an application, the module can work as an interval timer, which generates an interrupt after the selected time interval.

The Watchdog Timer counter (WDTCNT) is a 15/16-bit up-counter which is not directly accessible by software. The WDTCNT is controlled using the Watchdog Timer control register (WDTCTL), which is an 8-bit read/write register. Writing to WDTCTL, in both operating modes (watchdog or timer) is only possible by using the correct password in the high-byte. The low-byte stores data written to the WDTCTL. The high-byte password is 05Ah. If any value other than 05Ah is written to the high-byte of the WDTCTL, a system reset PUC is generated. *When the password is read its value is 069h.* This minimizes accidental write operations to the WDTCTL register. In addition to the Watchdog Timer control bits, two bits included in the WDTCTL configure the NMI pin.



MSP430C32x, MSP430P325A MIXED SIGNAL MICROCONTROLLER

SLAS219B – MARCH 1999 – REVISED MARCH 2000

8-bit Timer/Counter

The 8-bit interval timer supports three major functions for the application:

- Serial communication or data exchange
- Pulse counting or pulse accumulation
- Timer

The 8-bit Timer/Counter peripheral includes the following major blocks: an 8-bit Up-Counter with preload register, an 8-bit control register, an Input clock selector, an edge detection (e.g. Start bit detection for asynchronous protocols), and an input and output data latch, triggered by the carry-out-signal from the 8-bit counter.

The 8-bit counter counts up with an input clock which is selected by two control bits from the control register. The four possible clock sources are MCLK, ACLK, the external signal from terminal P0.1, and the signal from the logical AND of MCLK and terminal P0.1.

Two counter inputs (load, enable) control the counter operation. The load input controls load operations. A write-access to the counter results in loading the content of the preload register into the counter. The software writes or reads the preload register with all instructions. The preload register acts as a buffer and can be written immediately after the load of the counter is completed. The enable input enables the count operation. When the enable signal is set HIGH, the counter will count-up each time a positive clock edge is applied to the clock input of the counter.

Serial protocols, like UART protocol, need start-bit edge-detection to determine, at the receiver, the start of a data transmission. When this function is activated, the counter starts counting after the start-bit condition is detected. The first signal level is sampled into the RXD input data-latch after completing the first timing interval, which is programmed into the counter. Two latches are used for input and output data (RXD_FF and TXD_FF) are clocked by the counter after the programmed timing interval has elapsed.

UART

The serial communication is realized by using software and the 8-bit Timer/Counter hardware. The hardware supports the output of the serial data stream, bit-by-bit, with the timing determined by the counter. The software/hardware interface connects the mixed signal controller to external devices, systems, or networks.

Timer/Port

The Timer/Port module has two 8-bit counters, an input that triggers one counter, and six 3-state digital outputs. Both counters have an independent clock-selector for selecting an external signal or one of the internal clocks (ACLK or MCLK). One of the counters has an extended control capability to halt, count continuously, or gate the counter by selecting one of two external signals. This gate signal sets the interrupt flag, if an external signal is selected, and the gate stops the counter.

Both timers can be read from and written to by software. The two 8-bit counters can be cascaded to a 16-bit counter. A common interrupt vector is implemented. The interrupt flag can be set from three events in the 8-bit counter mode (gate signal, overflow from the counters) or from two events in the 16-bit counter mode (gate signal, overflow from the MSB of the cascaded counter).



POST OFFICE BOX 655303 • DALLAS, TEXAS 75265
POST OFFICE BOX 1443 • HOUSTON, TEXAS 77251-1443

absolute maximum ratings†

Voltage applied at V_{CC} to V_{SS} (see Note 5)	–0.3 V to 6 V
Voltage applied to any pin (referenced to V_{SS})	–0.3 V to $V_{CC} + 0.3$ V
Diode current at any device terminal	± 2 mA
Storage temperature, T_{stg} (unprogrammed device)	–55°C to 150°C
T_{stg} (programmed device)	–40°C to 85°C

† Stresses beyond those listed under “absolute maximum ratings” may cause permanent damage to the device. These are stress ratings only, and functional operation of the device at these or any other conditions beyond those indicated under “recommended operating conditions” is not implied. Exposure to absolute-maximum-rated conditions for extended periods may affect device reliability.

NOTE 5: All voltage values relative to V_{SS} .

recommended operating conditions

		MIN	NOM	MAX	UNIT
Supply voltage, V_{CC} (MSP430C32x)		2.5		5.5	V
Supply voltage, V_{CC} (MSP430P/E325A)		2.5		5.5	V
Supply voltage, during programming OTP/EPROM ($AV_{CC} = DV_{CC} = V_{CC}$)	MSP430P325A, PMS430E325A	4.5	5	5.5	V
Supply voltage, V_{SS}			0		V
Operating free-air temperature range, T_A	MSP430C32x, MSP430P325A	–40		85	°C
	PMS430E325A		25		
XTAL frequency, f_{XTAL}			32 768		Hz
Processor frequency (signal MCLK), $f_{(system)}$	$V_{CC} = 3$ V	DC		2.2	MHz
	$V_{CC} = 5$ V	DC		3.3	
Low-level input voltage, V_{IL} (excluding X_{in} , X_{out})	$V_{CC} = 3$ V/5 V	V_{SS}		$V_{SS} + 0.8$	V
High-level input voltage, V_{IH} (excluding X_{in} , X_{out})		$0.7 V_{CC}$		V_{CC}	
Low-level input voltage, $V_{IL}(X_{in}, X_{out})$		V_{SS}		$0.2 \times V_{CC}$	V
High-level input voltage, $V_{IH}(X_{in}, X_{out})$		$0.8 \times V_{CC}$		V_{CC}	

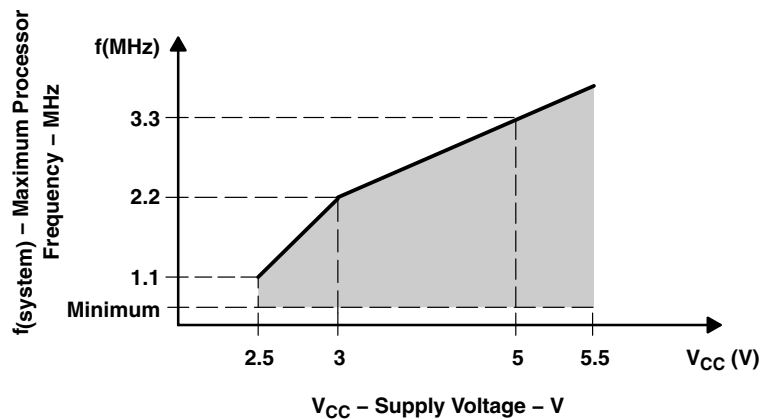

NOTE: Minimum processor frequency is defined by system clock.

Figure 1. Processor Frequency vs Supply Voltage

MSP430C32x, MSP430P325A MIXED SIGNAL MICROCONTROLLER

SLAS219B – MARCH 1999 – REVISED MARCH 2000

electrical characteristics over recommended operating free-air temperature range (unless otherwise noted)

supply current into $AV_{CC}+DV_{CC}$ excluding external current, $f_{system} = 1 \text{ MHz}$

PARAMETER		TEST CONDITIONS	MIN	TYP	MAX	UNIT
$I_{(AM)}$	Active mode, A/D conversion in power-down	C32x	400	500	800	900
	P325A	$T_A = -40^\circ\text{C}$ to 85°C , $V_{CC} = 3 \text{ V}$	500	550	950	1050
		$T_A = -40^\circ\text{C}$ to 85°C , $V_{CC} = 5 \text{ V}$				
$I_{(CPUOff)}$	Low power mode, (LPM0, LPM1)	C32x	50	70	100	130
	P325A	$T_A = -40^\circ\text{C}$ to 85°C , $V_{CC} = 3 \text{ V}$	50	70	100	130
		$T_A = -40^\circ\text{C}$ to 85°C , $V_{CC} = 5 \text{ V}$				
$I_{(LPM2)}$	Low power mode, (LPM2)	$T_A = -40^\circ\text{C}$ to 85°C , $V_{CC} = 3 \text{ V}$	6	12	15	25
		$T_A = -40^\circ\text{C}$ to 85°C , $V_{CC} = 5 \text{ V}$				
$I_{(LPM3)}$	Low power mode, (LPM3)	$V_{CC} = 3 \text{ V}$	$T_A = -40^\circ\text{C}$	1.5	2.4	μA
			$T_A = 25^\circ\text{C}$	1.3	2	
			$T_A = 85^\circ\text{C}$	1.6	2.8	
		$V_{CC} = 5 \text{ V}$	$T_A = -40^\circ\text{C}$	5.2	7	
			$T_A = 25^\circ\text{C}$	4.2	6.5	
			$T_A = 85^\circ\text{C}$	4	7	
$I_{(LPM4)}$	Low power mode, (LPM4)	$V_{CC} = 3 \text{ V}/5 \text{ V}$	$T_A = -40^\circ\text{C}$	0.1	0.8	μA
			$T_A = 25^\circ\text{C}$	0.1	0.8	
			$T_A = 85^\circ\text{C}$	0.4	1.3	

NOTE: All inputs are tied to 0 V or V_{CC} . Outputs do not source or sink any current. The current consumption in LPM2, LPM3 and LPM4 are measured with active Basic Timer1 (ACLK selected) and LCD Module ($f_{LCD}=1024 \text{ Hz}$, 4 MUX).

current consumption of active mode versus system frequency

$$I_{AM} = I_{AM[1 \text{ MHz}]} \times f_{system} [\text{MHz}]$$

current consumption of active mode versus supply voltage

$$I_{AM} = I_{AM[3 \text{ V}]} + 200 \mu\text{A/V} \times (V_{CC} - 3 \text{ V})$$

Schmitt-trigger inputs Port 0, P0.x Timer/Port, CIN, TP 0.5

PARAMETER		TEST CONDITIONS	MIN	TYP	MAX	UNIT
V_{IT+}	Positive-going input threshold voltage	$V_{CC} = 3 \text{ V}$	1.2		2.1	V
		$V_{CC} = 5 \text{ V}$	2.3		3.4	
V_{IT-}	Negative-going input threshold voltage	$V_{CC} = 3 \text{ V}$	0.5		1.35	
		$V_{CC} = 5 \text{ V}$	1.4		2.3	
V_{hys}	Hysteresis ($V_{IT+} - V_{IT-}$)	$V_{CC} = 3 \text{ V}$	0.3		1	
		$V_{CC} = 5 \text{ V}$	0.6		1.4	



electrical characteristics over recommended operating free-air temperature range (unless otherwise noted) (continued)

outputs – Port 0: P0.x; Timer/Port: TP0.0...5; LCD: Sxx/Oxx; XBUF, (see Note 6)

PARAMETER		TEST CONDITIONS			MIN	TYP	MAX	UNIT
V _{OH}	High-level output current	I _{OH} = -1.2 mA, V _{CC} = 3 V, See Note 6	V _{CC} -0.4		V _{CC}		V	
		I _{OH} = -3.5 mA, V _{CC} = 3 V, See Note 7	V _{CC} -1		V _{CC}			
		I _{OH} = -1.5 mA, V _{CC} = 5 V, See Note 6	V _{CC} -0.4		V _{CC}			
		I _{OH} = -4.5 mA, V _{CC} = 5 V, See Note 7	V _{CC} -1		V _{CC}			
V _{OL}	Low-level output voltage	I _{OL} = 1.2 mA, V _{CC} = 3 V, See Note 6	V _{SS}		V _{SS} +0.4		V	
		I _{OL} = 3.5 mA, V _{CC} = 3 V, See Note 7	V _{SS}		V _{SS} +1			
		I _{OL} = 1.5 mA, V _{CC} = 5 V, See Note 6	V _{SS}		V _{SS} +0.4			
		I _{OL} = 4.5 mA, V _{CC} = 5 V, See Note 7	V _{SS}		V _{SS} +1			

- NOTES: 6. The maximum total current, I_{OH}max and I_{OL}max, for all outputs combined, should not exceed ±9.6 mA to satisfy the maximum voltage drop specified.
7. The maximum total current, I_{OH}max and I_{OL}max, for all outputs combined, should not exceed ±20 mA to satisfy the maximum voltage drop specified.

leakage current (see Note 8)

PARAMETER		TEST CONDITIONS		MIN	TYP	MAX	UNIT
I _{lkg} (TP)	Leakage current, Timer/Port	Timer/Port: V _(TP0.x,CIN) (see Note 9)	V _{CC} = 3 V/5 V			±50	nA
I _{lkg} (P0x)	Leakage current, port 0	Port 0: V _(P0.x) (see Note 10)				±50	nA
I _{lkg} (S20)	Leakage current, S20	V _(S20) = V _{SS} to V _{CC}				±50	nA
I _{lkg} (Ax)	Leakage current, ADC	ADC: Ax, x= 0 to 5 (see Note 11)				±30	nA
I _{lkg} (RST/NMI)	Leakage current, RST/NMI					±50	nA

- NOTES: 8. The leakage current is measured with V_{SS} or V_{CC} applied to the corresponding pin(s), unless otherwise noted.
9. All Timer/Port pins TP0.0 to TP0.5 are Hi-Z. Pins CIN and TP.0 to TP0.5 are connected together during leakage current measurement. In the leakage measurement the input CIN is included. The input voltage is V_{SS} or V_{CC}.
10. The port pin must be selected for input and there must be no optional pullup or pulldown resistor.
11. The input voltage is V_(IN) = V_{SS} to V_{CC}, the current source is off, AEN.x bit is normally reset to stop throughput current flowing from V_{CC} to V_{SS} terminal.

optional resistors (see Note 12)

PARAMETER		TEST CONDITIONS	MIN	TYP	MAX	UNIT
R _(opt1)	Resistors, individually programmable with ROM code, all port pins, values applicable for pulldown and pullup	V _{CC} = 3 V/5 V	1.2	2.4	4.8	kΩ
R _(opt2)		V _{CC} = 3 V/5 V	1.8	3.6	7.2	kΩ
R _(opt3)		V _{CC} = 3 V/5 V	3.6	7.3	14.6	kΩ
R _(opt4)		V _{CC} = 3 V/5 V	5.5	11	22	kΩ
R _(opt5)		V _{CC} = 3 V/5 V	11	22	44	kΩ
R _(opt6)		V _{CC} = 3 V/5 V	22	44	88	kΩ
R _(opt7)		V _{CC} = 3 V/5 V	33	66	132	kΩ
R _(opt8)		V _{CC} = 3 V/5 V	55	110	220	kΩ
R _(opt9)		V _{CC} = 3 V/5 V	77	154	310	kΩ
R _(opt10)		V _{CC} = 3 V/5 V	100	200	400	kΩ

NOTE 12: Optional resistors R_(optx) for pulldown or pullup are not programmed in standard OTP/EPROM devices P/E 325A.



MSP430C32x, MSP430P325A MIXED SIGNAL MICROCONTROLLER

SLAS219B – MARCH 1999 – REVISED MARCH 2000

electrical characteristics over recommended operating free-air temperature range (unless otherwise noted) (continued)

input frequency – Port 0: P0.1; Timer/Port: CIN, TP0.5

PARAMETER	TEST CONDITIONS	MIN	TYP	MAX	UNIT	
$f_{(IN)}$ Input frequency	P0.x, CIN, TP.5	DC		$f_{(system)}$	MHz	
$t_{(H)}$ or $t_{(L)}$ High level or low level time		3 V	300			ns
		5 V	125			ns

output frequency

PARAMETER	TEST CONDITIONS	MIN	TYP	MAX	UNIT
f_{XBUF}	XBUF, $C_L = 20$ pF			$f_{(system)}$	MHz
t_{Xdc} Duty cycle of O/P frequency	XBUF, $C_L = 20$ pF, $V_{CC} = 3$ V/5 V	$f_{MCLK} = 1.1$ MHz	40%	60%	
		$f_{XBUF} = f_{ACLK}$	35%	65%	
		$f_{XBUF} = f_{ACLK/n}$		50%	

external interrupt timing

PARAMETER	TEST CONDITIONS	MIN	TYP	MAX	UNIT
$t_{(int)}$	Port P0: External trigger signal for the interrupt flag (see Notes 13 and 14)	1.5			cycle

NOTES: 13. The external signal sets the interrupt flag every time $t_{(int)}$ is met. It may be set even with trigger signals shorter than $t_{(int)}$. The conditions to set the flag must be met independently of this timing constraint. Input frequency ($t_{(int)}$) is defined in MCLK cycles.

14. The external signal needs additionally a timing resulting from the maximum input frequency constraint.

RAM

PARAMETER	TEST CONDITIONS	MIN	TYP	MAX	UNIT
V_{RAMh} CPU halted (see Note 15)		1.8			V

NOTE 15: This parameter defines the minimum supply voltage when the data in the program memory RAM remains unchanged. No program execution should take place during this supply voltage condition.



electrical characteristics over recommended operating free-air temperature range (unless otherwise noted) (continued)

DCO

PARAMETER		TEST CONDITIONS	MIN	TYP	MAX	UNIT
$f_{(NOM)}$	DCO	$N_{DCO} = 1A0h, FN_4=FN_3=FN_2=0$		1		MHz
$f_{(NOM)}$	f_{DCO3}	$N_{DCO} = 00\ 0110\ 0000, FN_4=FN_3=FN_2=0$	$V_{CC} = 3\ V$	0.15	0.6	MHz
			$V_{CC} = 5\ V$	0.18	0.62	
	f_{DCO26}	$N_{DCO} = 11\ 0100\ 0000, FN_4=FN_3=FN_2=0$	$V_{CC} = 3\ V$	1.25	4.7	MHz
			$V_{CC} = 5\ V$	1.45	5.5	
$2xf_{(NOM)}$	f_{DCO3}	$N_{DCO} = 00\ 0110\ 0000, FN_4=FN_3=0, FN_2=1$	$V_{CC} = 3\ V$	0.36	1.05	MHz
			$V_{CC} = 5\ V$	0.39	1.2	
	f_{DCO26}	$N_{DCO} = 11\ 0100\ 0000, FN_4=FN_3=0, FN_2=1$	$V_{CC} = 3\ V$	2.5	8.1	MHz
			$V_{CC} = 5\ V$	3	9.9	
$3xf_{(NOM)}$	f_{DCO3}	$N_{DCO} = 00\ 0110\ 0000, FN_4=0, FN_3=1, FN_2=X$	$V_{CC} = 3\ V$	0.5	1.5	MHz
			$V_{CC} = 5\ V$	0.6	1.8	
	f_{DCO26}	$N_{DCO} = 11\ 0100\ 0000, FN_4=0, FN_3=1, FN_2=X$	$V_{CC} = 3\ V$	3.7	11	MHz
			$V_{CC} = 5\ V$	4.5	13.8	
$4xf_{(NOM)}$	f_{DCO3}	$N_{DCO} = 00\ 0110\ 0000, FN_4=1, FN_3=FN_2=X$	$V_{CC} = 3\ V$	0.7	1.85	MHz
			$V_{CC} = 5\ V$	0.8	2.4	
	f_{DCO26}	$N_{DCO} = 11\ 0100\ 0000, FN_4=1, FN_3=FN_2=X$	$V_{CC} = 3\ V$	4.8	13.3	MHz
			$V_{CC} = 5\ V$	6	17.7	
N_{DCO}		$f_{MCLK} = f_{NOM}, FN_4=FN_3=FN_2=0$	$V_{CC} = 3\ V/5\ V$	A0h	1A0h	340h
S		$f_{NDCO+1} = S \times f_{NDCO}$	$V_{CC} = 3\ V/5\ V$	1.07		1.13

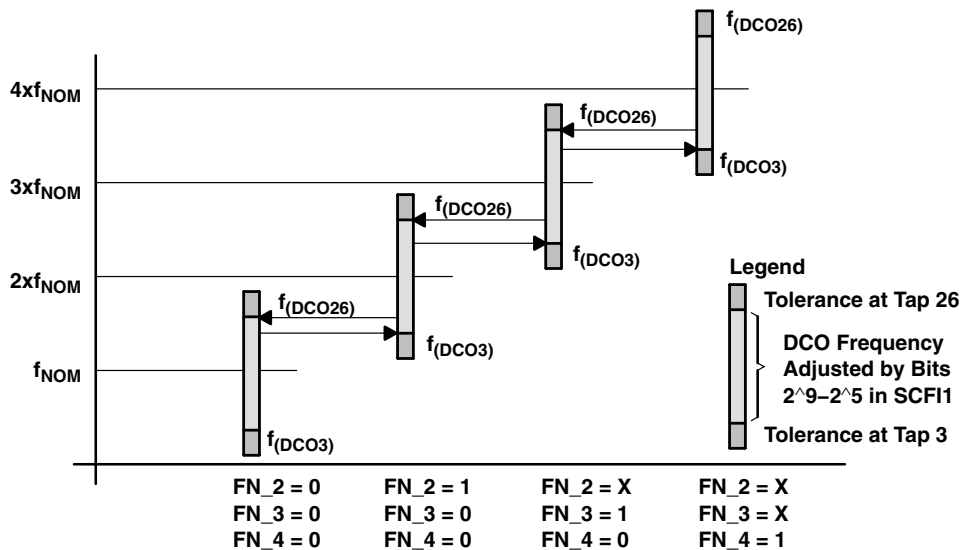

Figure 2

MSP430C32x, MSP430P325A MIXED SIGNAL MICROCONTROLLER

SLAS219B – MARCH 1999 – REVISED MARCH 2000

electrical characteristics over recommended operating free-air temperature range (unless otherwise noted) (continued)

crystal oscillator

PARAMETER		TEST CONDITIONS	MIN	NOM	MAX	UNIT
$C_{(Xin)}$	Integrated capacitance at input	$V_{CC} = 3 V/5 V$		12		pF
$C_{(Xout)}$	Integrated capacitance at output	$V_{CC} = 3 V/5 V$		12		pF

PUC/POR

PARAMETER		TEST CONDITIONS		MIN	NOM	MAX	UNIT
$t_{(POR_delay)}$	POR	$V_{CC} = 3 V/5 V$			150	250	μs
$V_{(POR)}$				$T_A = -40^\circ C$	1.5	2.4	V
				$T_A = 25^\circ C$	1.2	2.1	V
				$T_A = 85^\circ C$	0.9	1.8	V
$V_{(min)}$						0	0.4
$t_{(reset)}$	PUC/POR	Reset is accepted internally		2		μs	

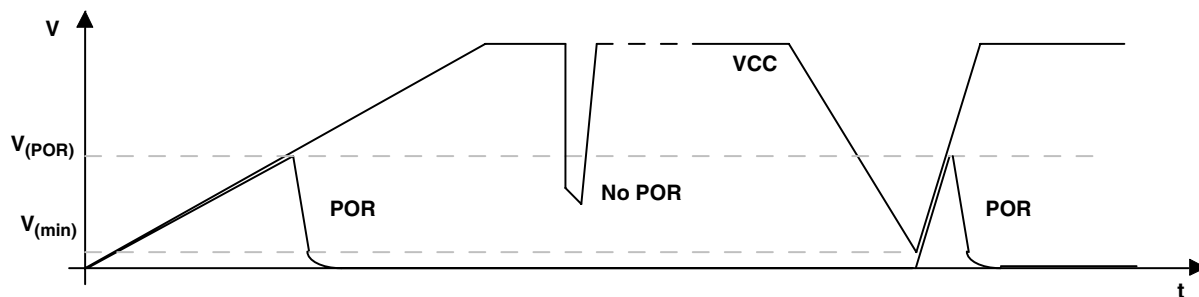

Figure 3. Power-On Reset (POR) vs Supply Voltage

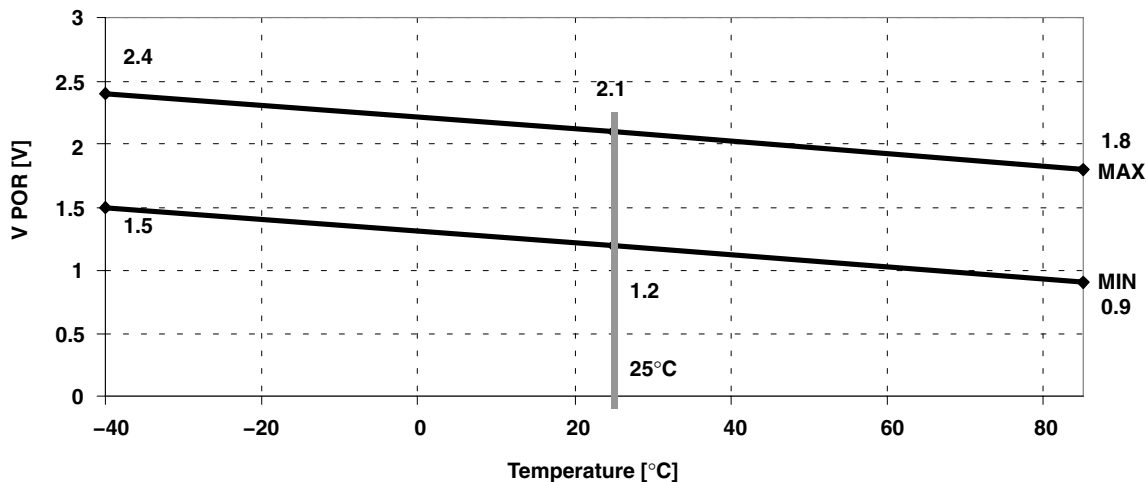

Figure 4. $V_{(POR)}$ vs Temperature



electrical characteristics over recommended operating free-air temperature range (unless otherwise noted) (continued)

LCD

PARAMETER		TEST CONDITIONS		MIN	TYP	MAX	UNIT
$V_{O(HLCD)}$	Output 1 (HLCD)	$I_{(HLCD)} \leq 10 \text{ nA}$	$V_{CC} = 3 \text{ V/5 V}$	$V_{CC}-0.125$		V_{CC}	V
$V_{O(LLCD)}$	Output 0 (LLCD)	$I_{(LLCD)} \leq 10 \text{ nA}$		V_{SS}		$V_{SS}+0.125$	
$I_{I(R03)}$	Input leakage	$R03 = V_{SS}$, No load at all seg and com pins	$V_{CC} = 3 \text{ V/5 V}$			± 20	nA
$I_{I(R13)}$		$R13 = V_{CC}/3$, No load at all seg and com pins					
$I_{I(R23)}$		$R23 = 2 V_{CC}/3$, No load at all seg and com pins					
$r_{O(Rx3 \text{ to } Sxx)}$	Resistance	$I_{(Sxx)} = -3 \mu\text{A}$,	$V_{CC} = 3 \text{ V/5 V}$			50	k Ω

comparator (Timer/Port)

PARAMETER		TEST CONDITIONS		MIN	TYP	MAX	UNIT
$I_{(com)}$	Comparator (Timer/Port)	CPON = 1	$V_{CC} = 3 \text{ V}$		250	350	μA
			$V_{CC} = 5 \text{ V}$		450	600	
$V_{ref(com)}$	Internal reference voltage at (-) terminal	CPON = 1	$V_{CC} = 3 \text{ V/5 V}$	$0.23 \times V_{CC}$	$0.25 \times V_{CC}$	$0.26 \times V_{CC}$	V
$V_{hys(com)}$	Input hysteresis (comparator)	CPON = 1	$V_{CC} = 3 \text{ V}$		5	37	mV
			$V_{CC} = 5 \text{ V}$		10	42	

wake-up LPM3

PARAMETER		TEST CONDITIONS		MIN	TYP	MAX	UNIT
$t_{(LPM3)}$	Delay time	f = 1 MHz	$V_{CC} = 3 \text{ V}$			6	μs
			$V_{CC} = 5 \text{ V}$				
		f = 2 MHz	$V_{CC} = 3 \text{ V}$			6	
			$V_{CC} = 5 \text{ V}$				
		f = 3 MHz	$V_{CC} = 5 \text{ V}$			6	

ADC supply current ($f_{(ADCLK)} = 1 \text{ MHz}$)

PARAMETER		TEST CONDITIONS		MIN	NOM	MAX	UNIT
$I_{(ADC)}$	ADC current	SV _{CC} on, current source off,	$V_{CC} = 3 \text{ V}$		200	400	μA
$I_{(ADC)}$			$V_{CC} = 5 \text{ V}$		300	740	μA

SV_{CC} (switched AV_{CC})

PARAMETER		TEST CONDITIONS		MIN	NOM	MAX	UNIT
$V_{(SVCC)}$		SV _{CC} on,	$I_{(SVCC)} = -8 \text{ mA}$, $V_{CC} = 2.5 \text{ V}$	$V_{CC}-0.2 \text{ V}$		V_{CC}	V
$I_{(SVCC)}$		SV _{CC} off,	SV _{CC} = 0 V, $V_{CC} = 5 \text{ V}$			± 0.1	μA
$Z_{(SVCC)}$	Input impedance	SV _{CC} off,	$V_{CC} = 3 \text{ V/5 V}$	40		100	k Ω



MSP430C32x, MSP430P325A MIXED SIGNAL MICROCONTROLLER

SLAS219B – MARCH 1999 – REVISED MARCH 2000

electrical characteristics over recommended operating free-air temperature range (unless otherwise noted) (continued)

current source (ADC)

PARAMETER	TEST CONDITIONS	MIN	TYP	MAX	UNIT
$V_{(Rext)}$ Voltage, (Rext)	$V_{(Rext)} = V_{(SVCC)} - V_{(RI)}$, $I_{(RI)} = 6 \text{ mA}$, $V_{CC} = 3 \text{ V/5 V}$,	$0.246 \times V_{(SVCC)}$	$0.249 \times V_{(SVCC)}$	$0.252 \times V_{(SVCC)}$	V
$R_{(ext)}$ External resistor	$V_{CC} = 3 \text{ V/5 V}$	95		1600	Ω
ΔI_S Load compliance	$VA0..A3 = 0 \dots 0.4 \times V_{(SVCC)}$, $I_S = V_{(Rext)}/R_{(ext)} = 1 \text{ mA}$, $V_{CC} = 3 \text{ V}$,	-1		1	μA
	$VA0..A3 = 0 \dots 0.4 \times V_{(SVCC)}$, $I_S = V_{(Rext)}/R_{(ext)} = 6 \text{ mA}$, $V_{CC} = 3 \text{ V}$,	-3.2		3.2	μA
	$VA0..A3 = 0 \dots 0.5 \times V_{(SVCC)}$, $I_S = V_{(Rext)}/R_{(ext)} = 1 \text{ mA}$, $V_{CC} = 5 \text{ V}$,	-1.5		1.5	μA
	$VA0..A3 = 0 \dots 0.5 \times V_{(SVCC)}$, $I_S = V_{(Rext)}/R_{(ext)} = 6 \text{ mA}$, $V_{CC} = 5 \text{ V}$,	-3.2		3.2	μA

A/D converter ($f_{(ADCLK)} = 1 \text{ MHz}$)

PARAMETER	TEST CONDITIONS	MIN	TYP	MAX	UNIT	
Resolution			12 + 2		bits	
$f_{(con)}$ Conversion frequency	$f_{(con)} = f_{(ADCLK)}$	12-bit conversion	0.1	1.5	MHz	
		12+2-bit conversion	0.14	1.5		
$f_{(conyc)}$ Conversion cycles	$f_{(ADCLK)} = f_{(MCLK)}/N$	12-bit conversion	96		cycles of ADCLK	
		12+2-bit conversion	132			
LSB Voltage	$V_{CC} = 3 \text{ V/5 V}$	$0.000061 \times V_{SVCC}$			V	
INL_1	Integral nonlinearity, (see Note 18)	$0 \leq DDV \leq 127$	$V_{CC} = 3 \text{ V/5 V}$	-2	2	LSB
INL_2		$128 \leq DDV \leq 255$	$V_{CC} = 3 \text{ V/5 V}$	-3	3	LSB
INL_3		$256 \leq DDV \leq 2047$	$V_{CC} = 3 \text{ V/5 V}$	-7	7	LSB
INL_4		$2048 \leq DDV \leq 4095$	$V_{CC} = 3 \text{ V/5 V}$	-10	10	LSB
DNL	Differential nonlinearity, (see Note 19)		$V_{CC} = 3 \text{ V/5 V}$	-1	1	LSB
dN/dT	Temperature stability	$V_{(Rext)}/R_{(ext)} = 6 \text{ mA}$, Range A	$V_{CC} = 3 \text{ V/5 V}$	0.008		LSB/°C
		Range B		0.015		
dN/dV(SVCC)	$V_{(SVCC)}$ rejection ratio	Range A, B, $V_{(Rext)}/R_{(ext)} = 1 \text{ mA}$, $SV_{CC} \pm 10\%$	$V_{CC} = 3 \text{ V/5 V}$	1.25		LSB/V
Conversion offset 12 bit analog input to digital value (see Note 16)	Range A	$V_{CC} = 3 \text{ V/5 V}$	-1.2	-0.49	0.24	%FSR _A (see Note 17)
	Range B	$V_{CC} = 3 \text{ V/5 V}$	-1.7	-0.6	0.49	%FSR _B (see Note 17)
	Range C	$V_{CC} = 3 \text{ V/5 V}$	-1.8	-0.6	0.6	%FSR _C (see Note 17)
	Range D	$V_{CC} = 3 \text{ V/5 V}$	-1.7	0.6	0.49	%FSR _D (see Note 17)
Conversion offset 14 bit analog input to digital value (see Note 16)	Range ABCD	$V_{CC} = 3 \text{ V/5 V}$	-0.27	-0.06	0.13	%FSR _{ABCD} (see Note 17)
Slope 12 bit		$V_{CC} = 3 \text{ V/5 V}$	0.9925	1	1.0075	
Slope 14 bit		$V_{CC} = 3 \text{ V/5 V}$	0.9982	1	1.0018	
$C_{(IN)}$ Input capacitance		$V_{CC} = 3 \text{ V/5 V}$	40	45		pF
$R_{(SIN)}$ Serial input resistance		$V_{CC} = 3 \text{ V/5 V}$	2			k Ω

NOTES: 16. Offset referred to full scale 12/14 bit

17. FSRx: full scale range, separate for the four 12-bit ranges and the 14-bit (12+2) range.

18. DDV is short form of delta digital value. The DDV is a span of conversion results. It is assumed that the conversion is of 12 bit not 12+2 bit.

19. DNL is valid for all 12-bit ranges and the 14-bit (12+2) range.



MSP430C32x, MSP430P325A MIXED SIGNAL MICROCONTROLLER

SLAS219B – MARCH 1999 – REVISED MARCH 2000

electrical characteristics over recommended operating free-air temperature range (unless otherwise noted) (continued)

JTAG

PARAMETER		TEST CONDITIONS	MIN	TYP	MAX	UNIT		
$f_{(TCK)}$	JTAG/Test	TCK frequency	$V_{CC} = 3\text{ V}$	DC	5	MHz		
			$V_{CC} = 5\text{ V}$	DC	10			
$R_{(TEST)}$		Pullup resistors on TMS, TCK, TDI (see Note 20)	$V_{CC} = 3\text{ V}/5\text{ V}$	25	60	90	k Ω	
$V_{(FB)}$	JTAG/Fuse (see Note 21)	Fuse blow voltage, C versions (see Note 22)	$V_{CC} = 3\text{ V}/5\text{ V}$	5.5		6	V	
		Fuse blow voltage, E/P versions (see Note 22)	$V_{CC} = 3\text{ V}/5\text{ V}$	11		12		
$I_{(FB)}$		Supply current on TDI to blow fuse				100	mA	
$t_{(FB)}$		Time to blow the fuse				1	ms	
$V_{(PP)}$	EPROM (E) and OTP(P) – versions only	Programming voltage, applied to TDI/VPP		12	12.5	13	V	
$I_{(PP)}$		Current from programming voltage source				70	mA	
$t_{(pps)}$		Programming time, single pulse		5			ms	
$t_{(ppf)}$		Programming time, fast algorithm			100		μs	
P_n		Number of pulses for successful programming		4		100		
		Data retention $T_J < 55^\circ\text{C}$		10			year	
$t_{(erase)}$		EPROM (E) versions only	Erase time wave length 2537 Å at 15 Ws/cm ² (UV lamp of 12 mW/cm ²)		30			min
			Write/Erase cycles		1000			cycles

- NOTES: 20. The TMS and TCK pullup resistors are implemented in all C-, P-, and E-versions. The pullup resistor on TDI is implemented in C-versions only.
21. Once the JTAG fuse is blown, no further access to the MSP430 JTAG/test feature is possible. The JTAG block switches to by-pass mode.
22. The voltage supply to blow the JTAG fuse is applied to TDI/VPP pin when fuse blowing is desired.



MSP430C32x, MSP430P325A MIXED SIGNAL MICROCONTROLLER

SLAS219B – MARCH 1999 – REVISED MARCH 2000

TYPICAL CHARACTERISTICS

DIGITAL CONTROLLED OSCILLATOR FREQUENCY
vs
OPERATING FREE-AIR TEMPERATURE

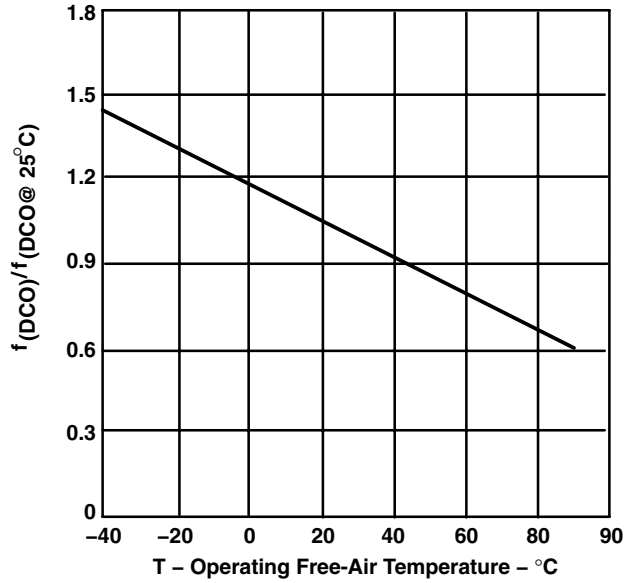

Figure 5

DIGITAL CONTROLLED OSCILLATOR FREQUENCY
vs
SUPPLY VOLTAGE

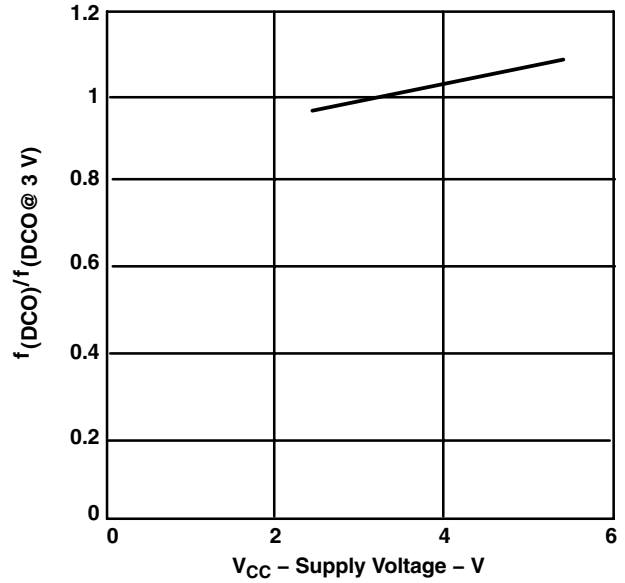
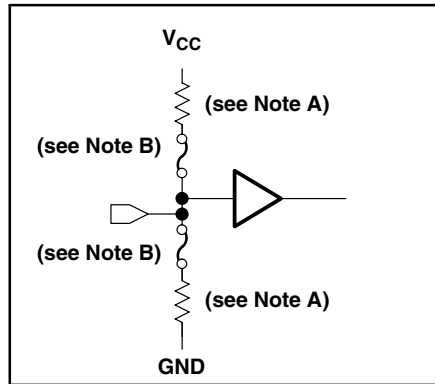

Figure 6

TYPICAL CHARACTERISTICS

typical input/output schematics



CMOS INPUT (RST/NMI)

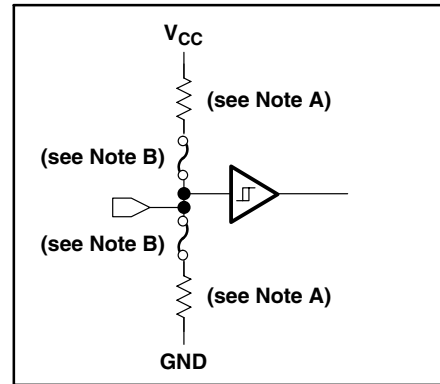

CMOS SCHMITT-TRIGGER INPUT (CIN)

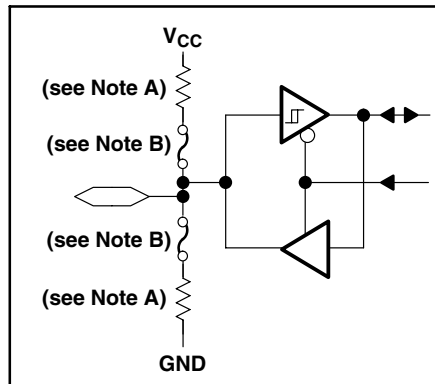

I/O WITH SCHMITT-TRIGGER INPUT (P0.x, TP5)

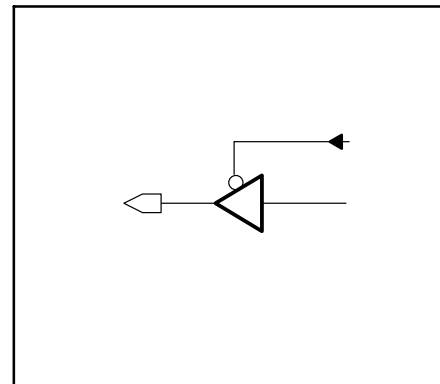

CMOS 3-STATE OUTPUT
(TP0-4, XBUF)

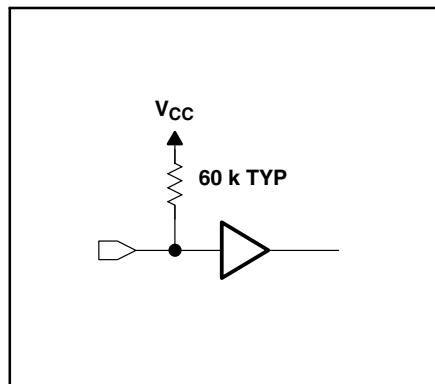

MSP430C32x: TMS, TCK, TDI
MSP430P/E325A: TMS, TCK

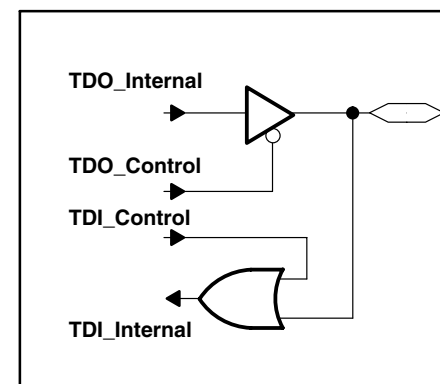

MSP430C32x: TDO/TDI
MSP430P/E325A: TDO/TDI

- NOTES: A. Optional selection of pullup or pulldown resistors with ROM (masked) versions. Anti-parallel diodes are connected between AV_{SS} and DV_{SS} .
B. Fuses for the optional pullup and pulldown resistors can only be programmed at the factory.

MSP430C32x, MSP430P325A MIXED SIGNAL MICROCONTROLLER

SLAS219B – MARCH 1999 – REVISED MARCH 2000

TYPICAL CHARACTERISTICS

typical input/output schematics

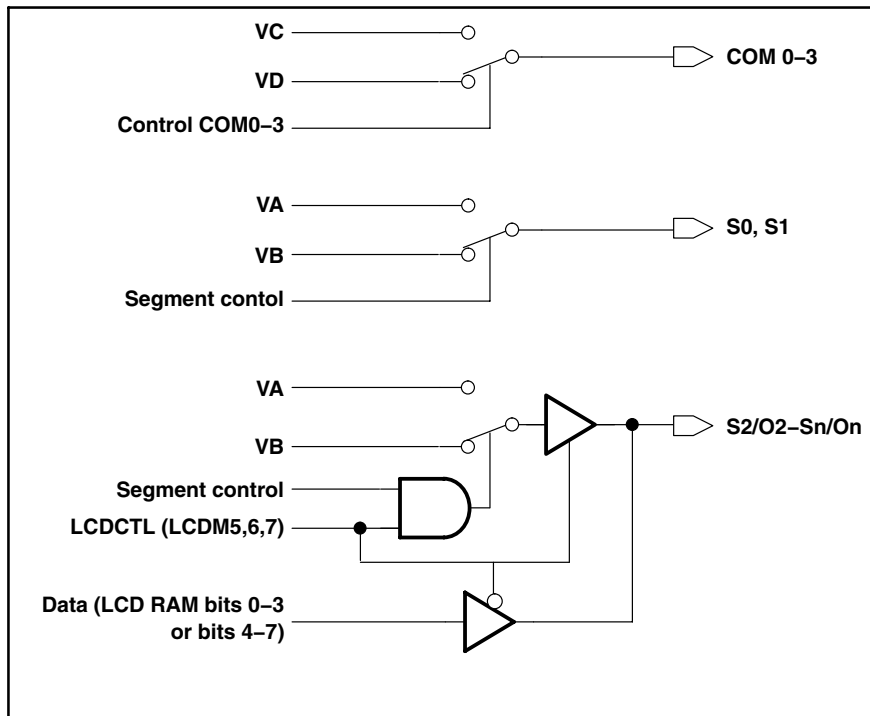

LCD OUTPUT (COM0-4, Sn, Sn/On)

NOTE: The signals VA, VB, VC, and VD come from the LCD module analog voltage generator.

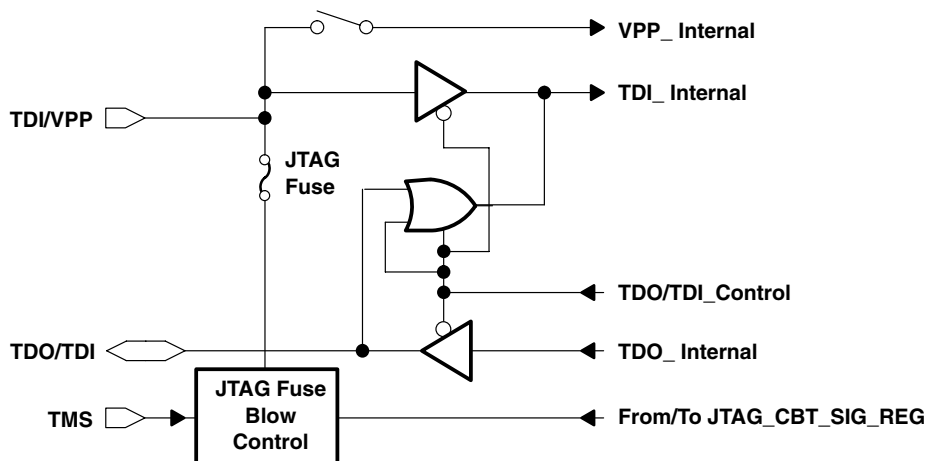

- NOTES:
- A. During programming activity and when blowing the JTAG enable fuse, the TDI/VPP terminal is used to apply the correct voltage source. The TDO/TDI terminal is used to apply the test input data for JTAG circuitry.
 - B. The TDI/VPP terminal of the 'P325A and 'E325A does not have an internal pullup resistor. An external pulldown resistor is recommended to avoid a floating node which could increase the current consumption of the device.
 - C. The TDO/TDI terminal is in a high-impedance state after POR. The 'P325A and 'E325A needs a pullup or a pulldown resistor to avoid floating a node which could increase the current consumption of the device.

Figure 7. MSP430P325A/E325A: TDI/VPP, TDO/TDI

TYPICAL CHARACTERISTICS

JTAG fuse check mode

MSP430 devices that have the fuse on the TDI/VPP terminal have a fuse check mode that tests the continuity of the fuse the first time the JTAG port is accessed after a power-on reset (POR). When activated, a fuse check current, I_{TF} , of 1 mA at 3 V, 2.5 mA at 5 V can flow from the TDI/VPP pin to ground if the fuse is not burned. Care must be taken to avoid accidentally activating the fuse check mode and increasing overall system power consumption.

Activation of the fuse check mode occurs with the first negative edge on the TMS pin after power up or if TMS is being held low during power up. The second positive edge on the TMS pin deactivates the fuse check mode. After deactivation, the fuse check mode remains inactive until another POR occurs. After each POR the fuse check mode has the potential to be activated.

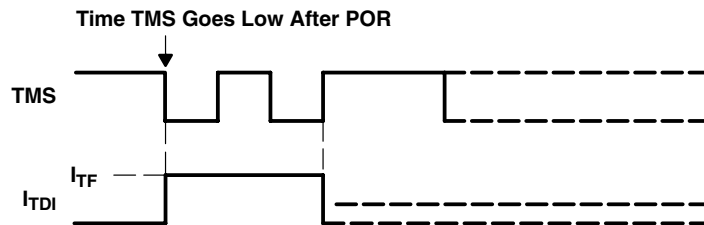

Figure 8. Fuse Check Mode Current, MSP430P/E325A, C32x

Care must be taken to avoid accidentally activating the fuse check mode, including guarding against EMI/ESD spikes that could cause signal edges on the TMS pin.

Configuration of TMS, TCK, TDI/VPP and TDO/TDI pins in applications.

	C3xx	P/E3xx
TDI	Open	68k, pulldown
TDO	Open	68k, pulldown
TMS	Open	Open
TCK	Open	Open

MSP430C32x, MSP430P325A MIXED SIGNAL MICROCONTROLLER

SLAS219B – MARCH 1999 – REVISED MARCH 2000

MECHANICAL DATA

pinning MSP43C323, MSP430C325, MSP430P325A (PM package)

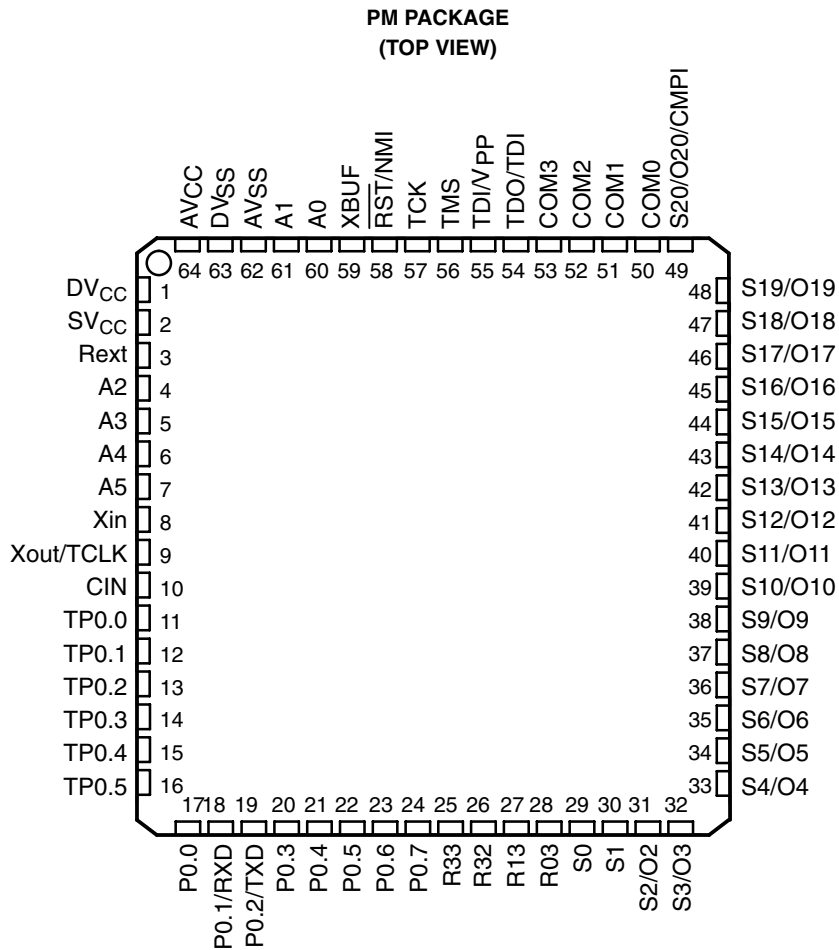

pinning MSP43C323, MSP430C325, MSP430P325A (FN package)

MSP430C32x, MSP430P325A MIXED SIGNAL MICROCONTROLLER

SLAS219B – MARCH 1999 – REVISED MARCH 2000

FN PACKAGE (TOP VIEW)

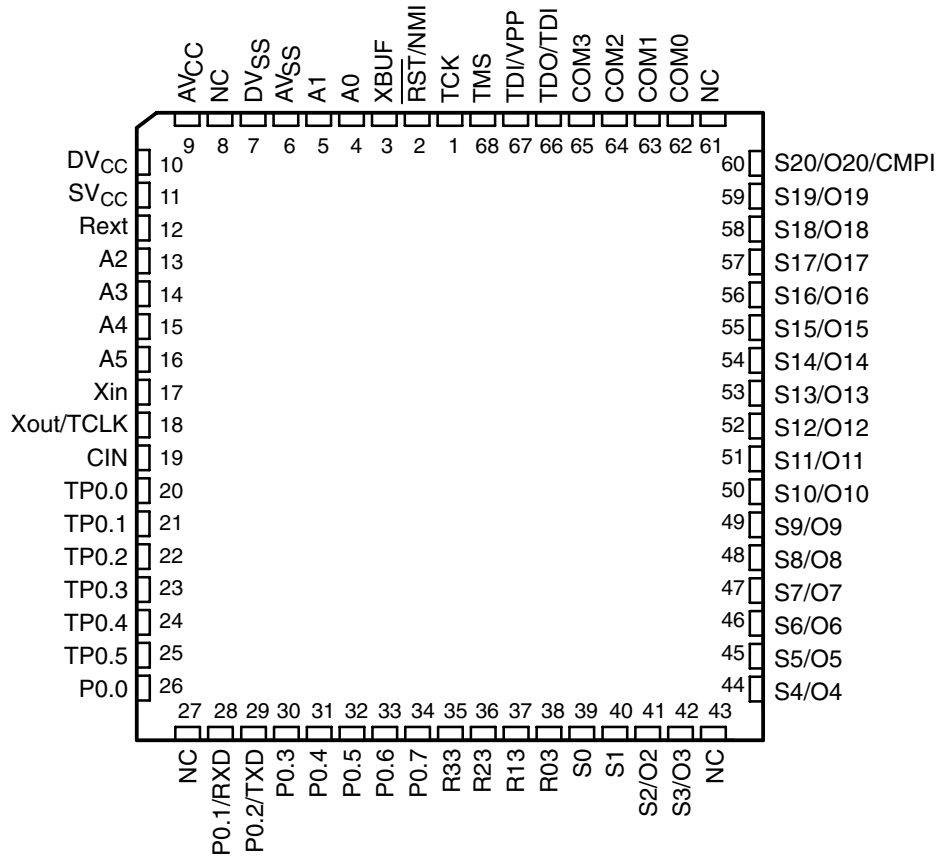

MSP430C32x, MSP430P325A MIXED SIGNAL MICROCONTROLLER

SLAS219B – MARCH 1999 – REVISED MARCH 2000

pinning PMS430E325A (FZ package)

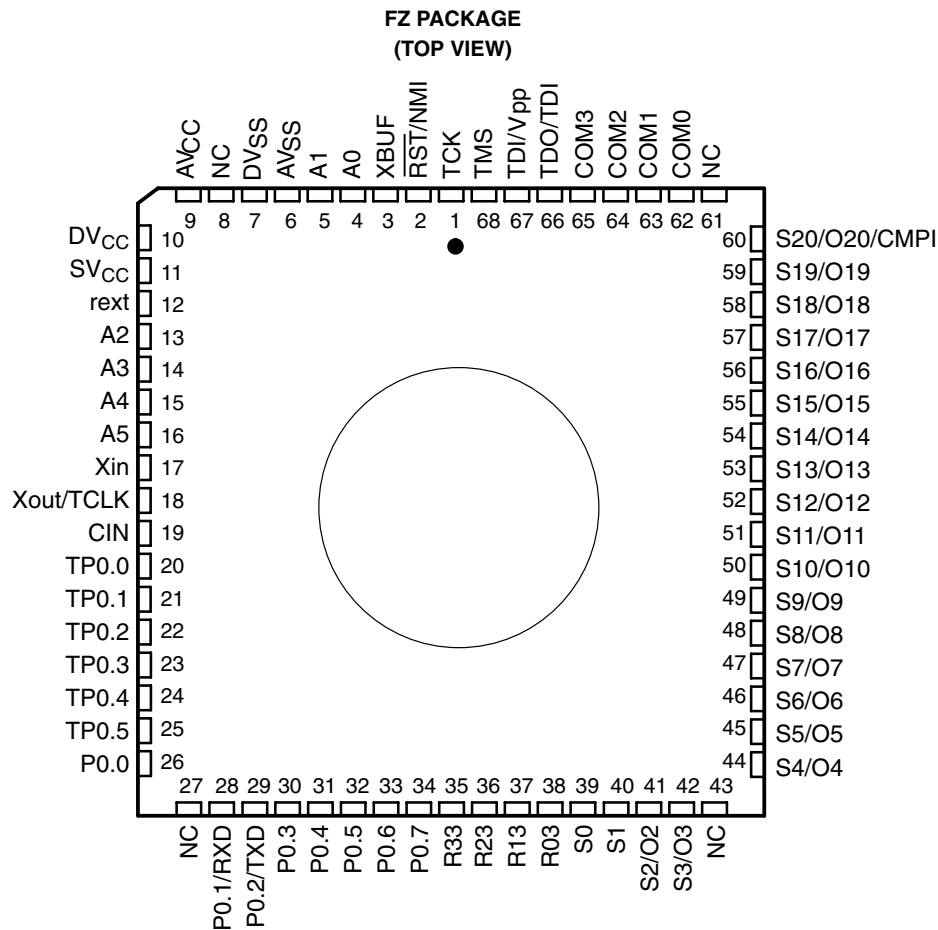

MSP430C32x, MSP430P325A MIXED SIGNAL MICROCONTROLLER

SLAS219B – MARCH 1999 – REVISED MARCH 2000

MECHANICAL DATA

FZ (S-CQCC-J**)

J-LEADED CERAMIC CHIP CARRIER

28 LEAD SHOWN

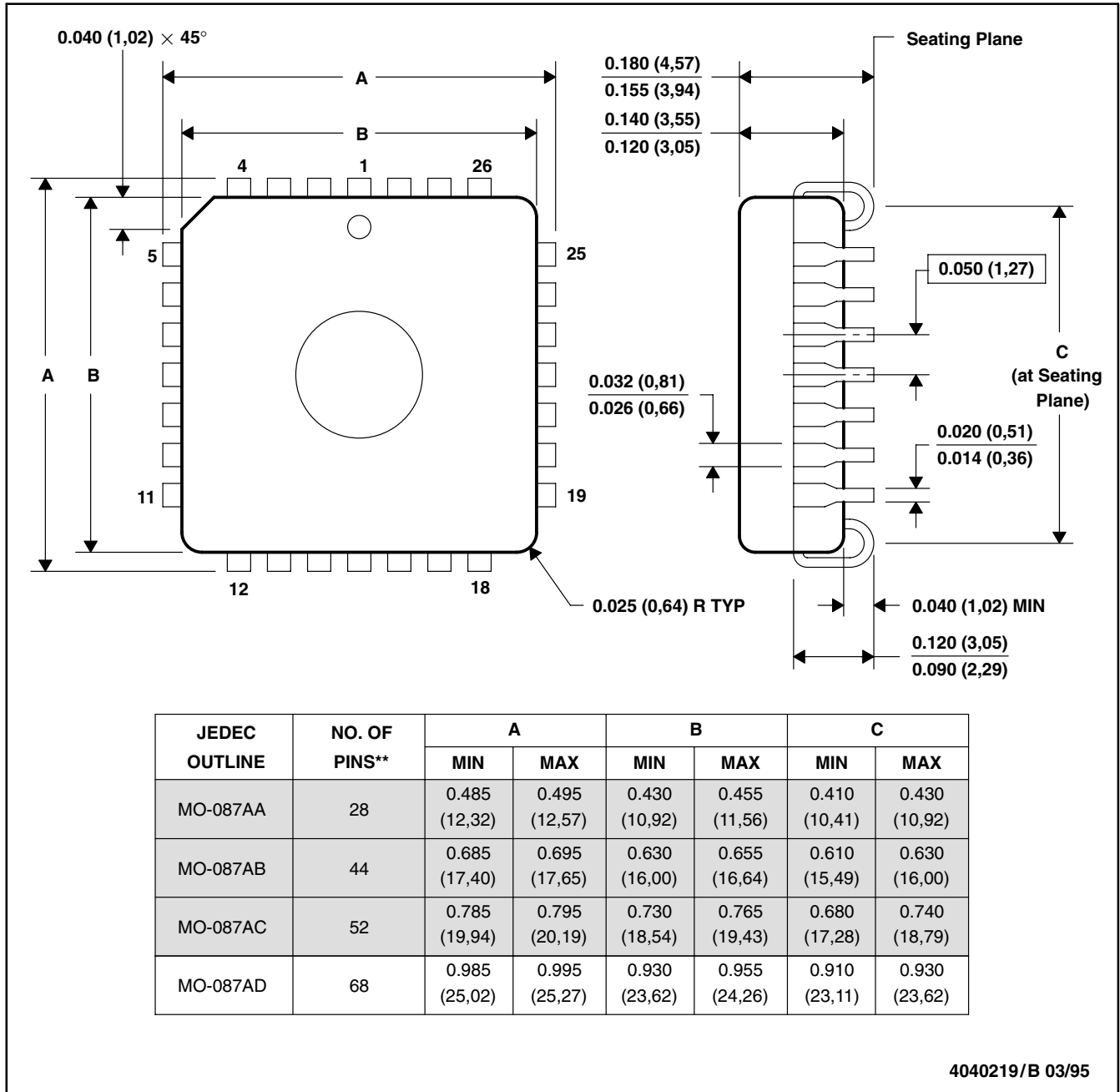

- NOTES: A. All linear dimensions are in inches (millimeters).
 B. This drawing is subject to change without notice.
 C. This package can be hermetically sealed with a ceramic lid using glass frit.



PACKAGING INFORMATION

Orderable Device	Status ⁽¹⁾	Package Type	Package Drawing	Pins	Package Qty	Eco Plan ⁽²⁾	Lead/ Ball Finish	MSL Peak Temp ⁽³⁾	Samples (Requires Login)
MSP430P325AIFN	NRND	PLCC	FN	68	18	Green (RoHS & no Sb/Br)	CU NIPDAU	Level-4-260C-72 HR	
MSP430P325AIPG	NRND	QFP	PG	64	66	Green (RoHS & no Sb/Br)	CU NIPDAU	Level-3-260C-168 HR	
MSP430P325AIPM	NRND	LQFP	PM	64	160	Green (RoHS & no Sb/Br)	CU NIPDAU	Level-3-260C-168 HR	
PMS430E325FZ	OBSOLETE	JLCC	FZ	68		TBD	Call TI	Call TI	

⁽¹⁾ The marketing status values are defined as follows:

ACTIVE: Product device recommended for new designs.

LIFEBUY: TI has announced that the device will be discontinued, and a lifetime-buy period is in effect.

NRND: Not recommended for new designs. Device is in production to support existing customers, but TI does not recommend using this part in a new design.

PREVIEW: Device has been announced but is not in production. Samples may or may not be available.

OBSOLETE: TI has discontinued the production of the device.

⁽²⁾ Eco Plan - The planned eco-friendly classification: Pb-Free (RoHS), Pb-Free (RoHS Exempt), or Green (RoHS & no Sb/Br) - please check <http://www.ti.com/productcontent> for the latest availability information and additional product content details.

TBD: The Pb-Free/Green conversion plan has not been defined.

Pb-Free (RoHS): TI's terms "Lead-Free" or "Pb-Free" mean semiconductor products that are compatible with the current RoHS requirements for all 6 substances, including the requirement that lead not exceed 0.1% by weight in homogeneous materials. Where designed to be soldered at high temperatures, TI Pb-Free products are suitable for use in specified lead-free processes.

Pb-Free (RoHS Exempt): This component has a RoHS exemption for either 1) lead-based flip-chip solder bumps used between the die and package, or 2) lead-based die adhesive used between the die and leadframe. The component is otherwise considered Pb-Free (RoHS compatible) as defined above.

Green (RoHS & no Sb/Br): TI defines "Green" to mean Pb-Free (RoHS compatible), and free of Bromine (Br) and Antimony (Sb) based flame retardants (Br or Sb do not exceed 0.1% by weight in homogeneous material)

⁽³⁾ MSL, Peak Temp. -- The Moisture Sensitivity Level rating according to the JEDEC industry standard classifications, and peak solder temperature.

Important Information and Disclaimer: The information provided on this page represents TI's knowledge and belief as of the date that it is provided. TI bases its knowledge and belief on information provided by third parties, and makes no representation or warranty as to the accuracy of such information. Efforts are underway to better integrate information from third parties. TI has taken and continues to take reasonable steps to provide representative and accurate information but may not have conducted destructive testing or chemical analysis on incoming materials and chemicals. TI and TI suppliers consider certain information to be proprietary, and thus CAS numbers and other limited information may not be available for release.

In no event shall TI's liability arising out of such information exceed the total purchase price of the TI part(s) at issue in this document sold by TI to Customer on an annual basis.

FN (S-PQCC-J**)

PLASTIC J-LEADED CHIP CARRIER

20 PIN SHOWN

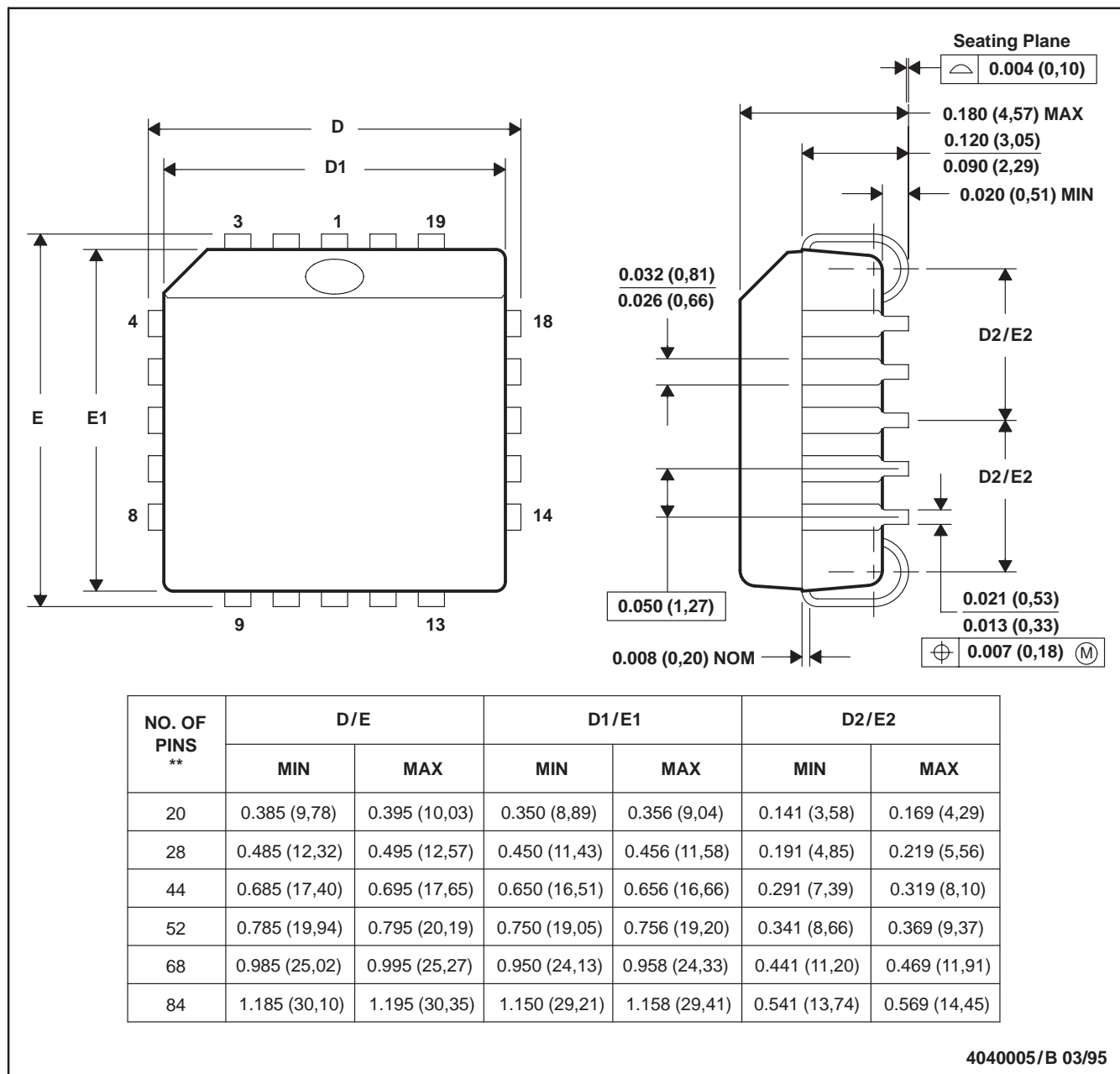

- NOTES: A. All linear dimensions are in inches (millimeters).
 B. This drawing is subject to change without notice.
 C. Falls within JEDEC MS-018

PG (R-PQFP-G64)

PLASTIC QUAD FLATPACK

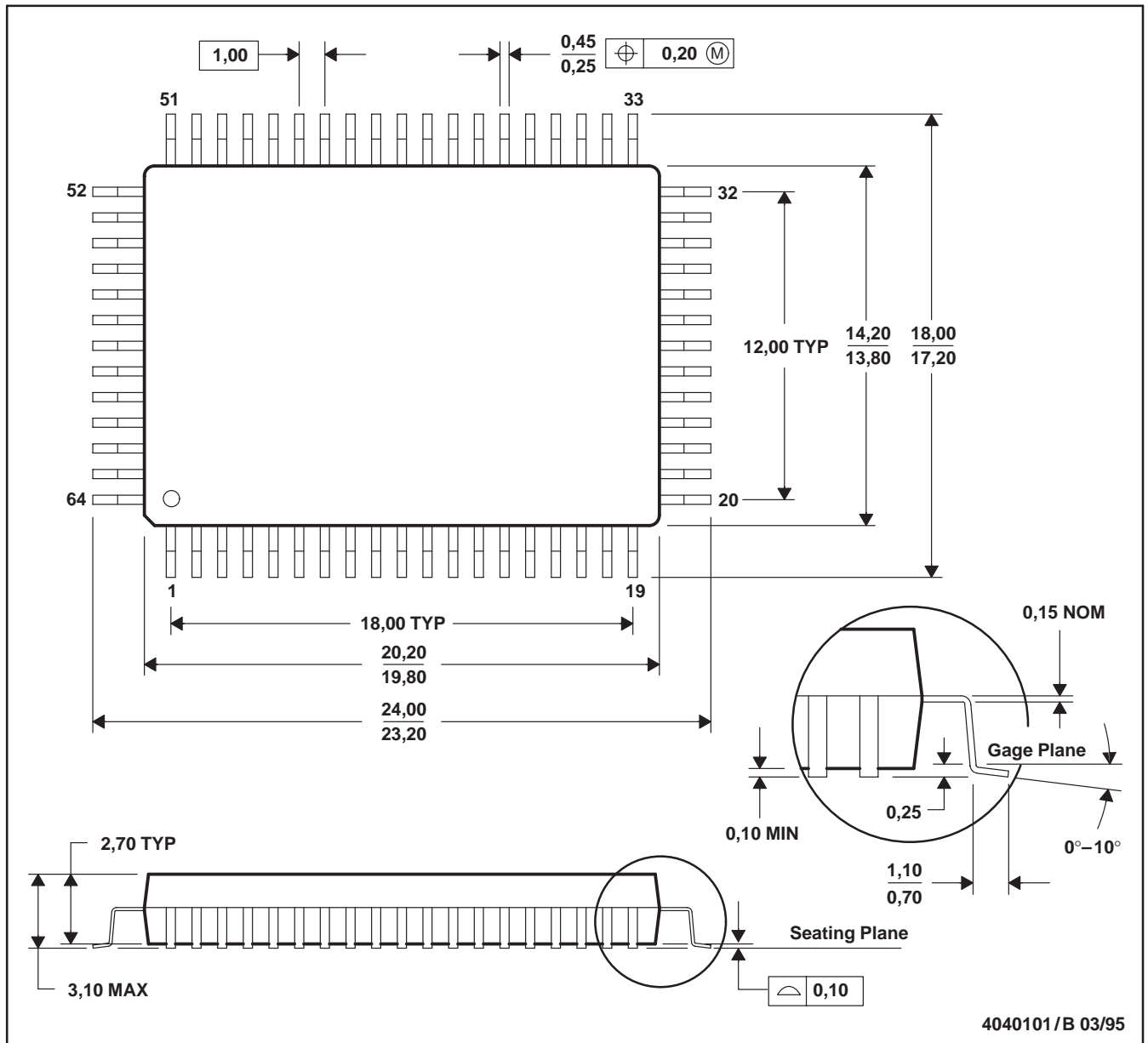

- NOTES: A. All linear dimensions are in millimeters.
 B. This drawing is subject to change without notice.
 C. Contact field sales office to determine if a tighter coplanarity requirement is available for this package.

PM (S-PQFP-G64)

PLASTIC QUAD FLATPACK

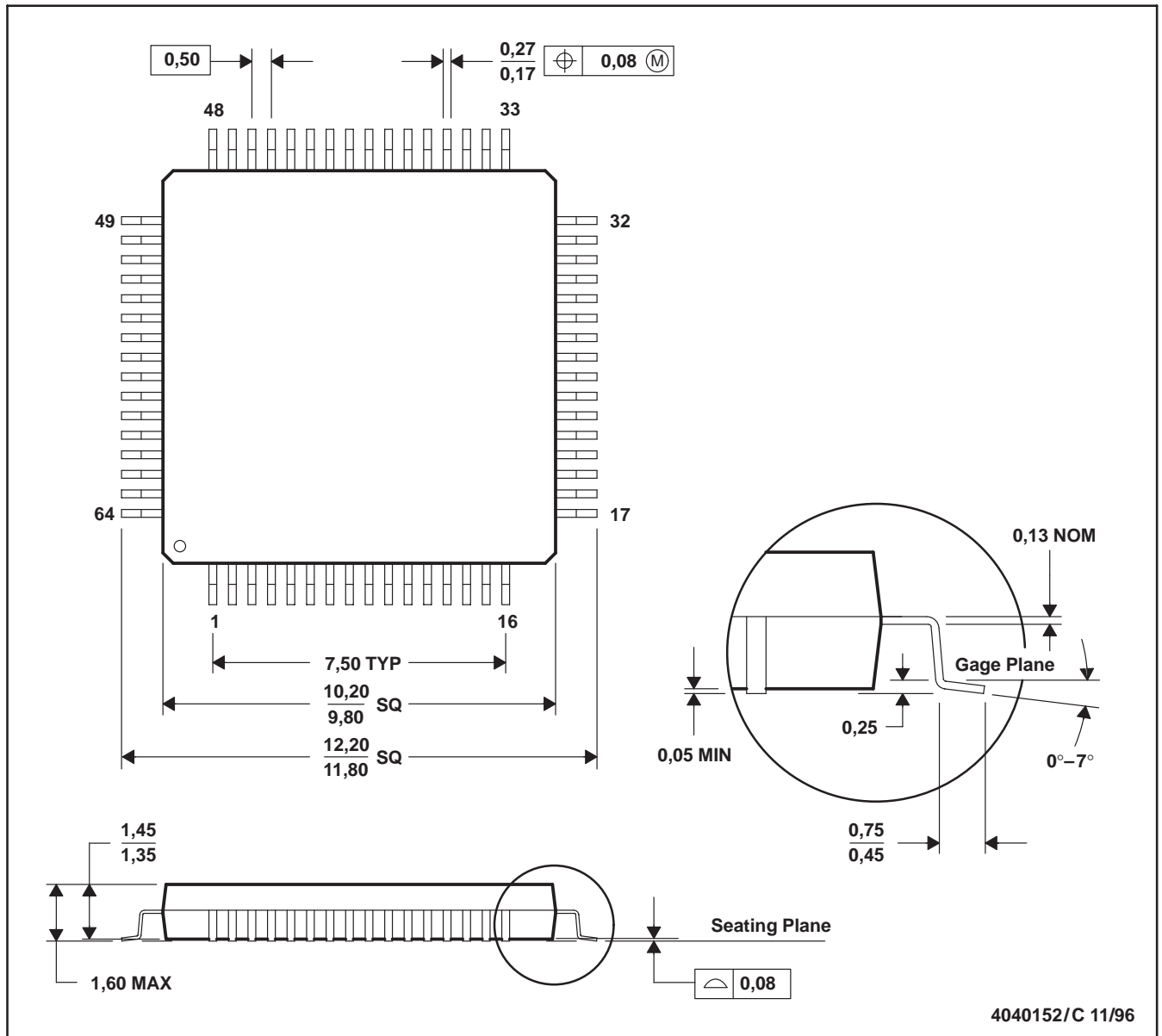

- NOTES: A. All linear dimensions are in millimeters.
 B. This drawing is subject to change without notice.
 C. Falls within JEDEC MS-026
 D. May also be thermally enhanced plastic with leads connected to the die pads.

PM (S-PQFP-G64)

PLASTIC QUAD FLATPACK

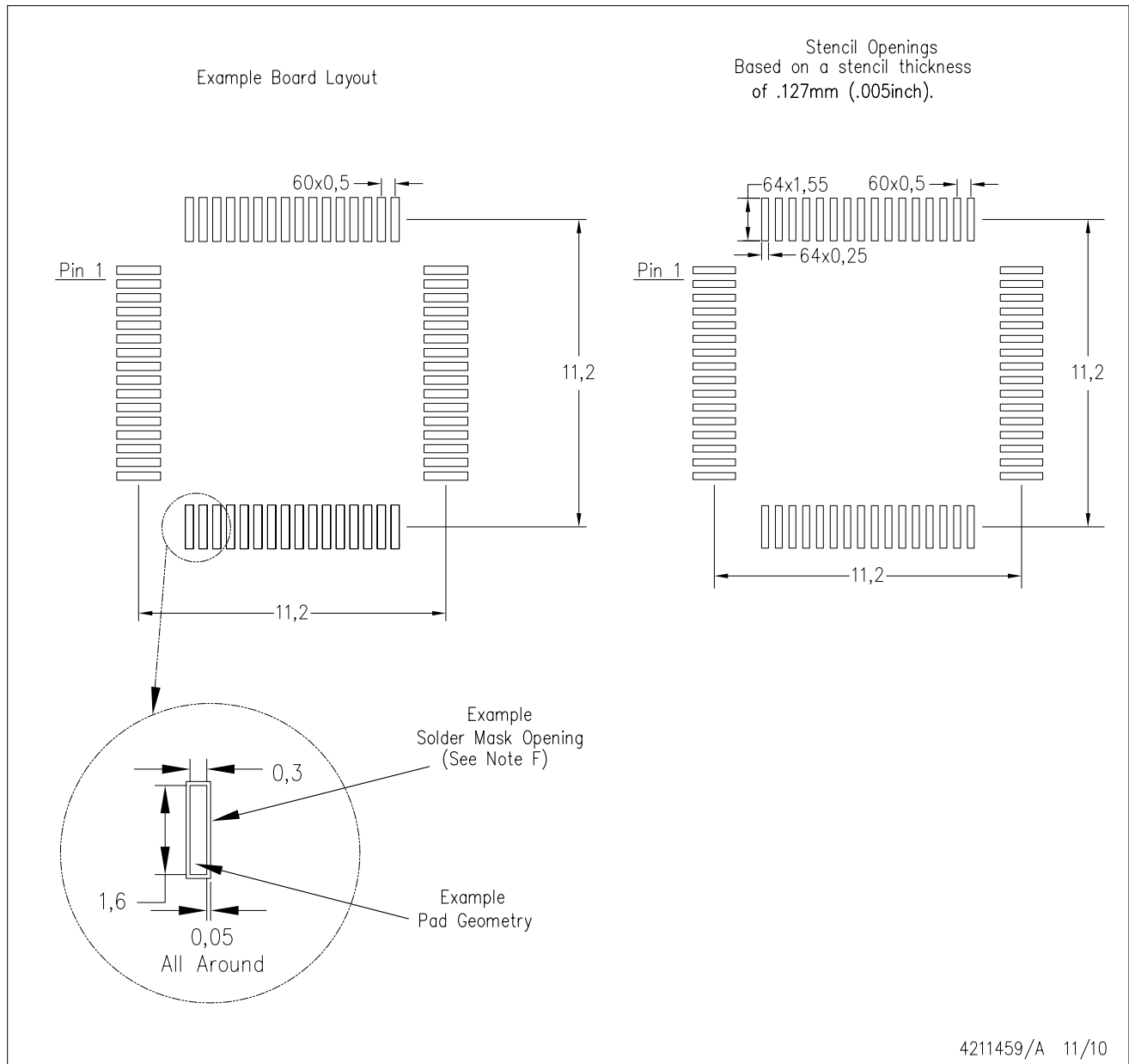

- NOTES:
- A. All linear dimensions are in millimeters.
 - B. This drawing is subject to change without notice.
 - C. Laser cutting apertures with trapezoidal walls and also rounding corners will offer better paste release. Customers should contact their board assembly site for stencil design recommendations. Example stencil design based on a 50% volumetric metal load solder paste. Refer to IPC-7525 for other stencil recommendations.
 - D. Customers should contact their board fabrication site for solder mask tolerances between and around signal pads.

IMPORTANT NOTICE

Texas Instruments Incorporated and its subsidiaries (TI) reserve the right to make corrections, modifications, enhancements, improvements, and other changes to its products and services at any time and to discontinue any product or service without notice. Customers should obtain the latest relevant information before placing orders and should verify that such information is current and complete. All products are sold subject to TI's terms and conditions of sale supplied at the time of order acknowledgment.

TI warrants performance of its hardware products to the specifications applicable at the time of sale in accordance with TI's standard warranty. Testing and other quality control techniques are used to the extent TI deems necessary to support this warranty. Except where mandated by government requirements, testing of all parameters of each product is not necessarily performed.

TI assumes no liability for applications assistance or customer product design. Customers are responsible for their products and applications using TI components. To minimize the risks associated with customer products and applications, customers should provide adequate design and operating safeguards.

TI does not warrant or represent that any license, either express or implied, is granted under any TI patent right, copyright, mask work right, or other TI intellectual property right relating to any combination, machine, or process in which TI products or services are used. Information published by TI regarding third-party products or services does not constitute a license from TI to use such products or services or a warranty or endorsement thereof. Use of such information may require a license from a third party under the patents or other intellectual property of the third party, or a license from TI under the patents or other intellectual property of TI.

Reproduction of TI information in TI data books or data sheets is permissible only if reproduction is without alteration and is accompanied by all associated warranties, conditions, limitations, and notices. Reproduction of this information with alteration is an unfair and deceptive business practice. TI is not responsible or liable for such altered documentation. Information of third parties may be subject to additional restrictions.

Resale of TI products or services with statements different from or beyond the parameters stated by TI for that product or service voids all express and any implied warranties for the associated TI product or service and is an unfair and deceptive business practice. TI is not responsible or liable for any such statements.

TI products are not authorized for use in safety-critical applications (such as life support) where a failure of the TI product would reasonably be expected to cause severe personal injury or death, unless officers of the parties have executed an agreement specifically governing such use. Buyers represent that they have all necessary expertise in the safety and regulatory ramifications of their applications, and acknowledge and agree that they are solely responsible for all legal, regulatory and safety-related requirements concerning their products and any use of TI products in such safety-critical applications, notwithstanding any applications-related information or support that may be provided by TI. Further, Buyers must fully indemnify TI and its representatives against any damages arising out of the use of TI products in such safety-critical applications.

TI products are neither designed nor intended for use in military/aerospace applications or environments unless the TI products are specifically designated by TI as military-grade or "enhanced plastic." Only products designated by TI as military-grade meet military specifications. Buyers acknowledge and agree that any such use of TI products which TI has not designated as military-grade is solely at the Buyer's risk, and that they are solely responsible for compliance with all legal and regulatory requirements in connection with such use.

TI products are neither designed nor intended for use in automotive applications or environments unless the specific TI products are designated by TI as compliant with ISO/TS 16949 requirements. Buyers acknowledge and agree that, if they use any non-designated products in automotive applications, TI will not be responsible for any failure to meet such requirements.

Following are URLs where you can obtain information on other Texas Instruments products and application solutions:

Products

Audio	www.ti.com/audio
Amplifiers	amplifier.ti.com
Data Converters	dataconverter.ti.com
DLP® Products	www.dlp.com
DSP	dsp.ti.com
Clocks and Timers	www.ti.com/clocks
Interface	interface.ti.com
Logic	logic.ti.com
Power Mgmt	power.ti.com
Microcontrollers	microcontroller.ti.com
RFID	www.ti-rfid.com
OMAP Mobile Processors	www.ti.com/omap
Wireless Connectivity	www.ti.com/wirelessconnectivity

Applications

Automotive and Transportation	www.ti.com/automotive
Communications and Telecom	www.ti.com/communications
Computers and Peripherals	www.ti.com/computers
Consumer Electronics	www.ti.com/consumer-apps
Energy and Lighting	www.ti.com/energy
Industrial	www.ti.com/industrial
Medical	www.ti.com/medical
Security	www.ti.com/security
Space, Avionics and Defense	www.ti.com/space-avionics-defense
Video and Imaging	www.ti.com/video

TI E2E Community Home Page

e2e.ti.com

Mailing Address: Texas Instruments, Post Office Box 655303, Dallas, Texas 75265
Copyright © 2012, Texas Instruments Incorporated