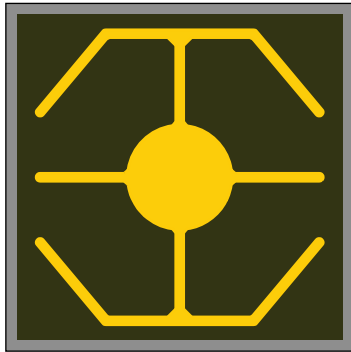


Specification of High Power IR Emitting Diode Chip



FEATURES

- Package type: chip
- Package form: single chip
- Technology: surface emitter
- Dimensions chip (L x W x H in mm): 0.355 x 0.355 x 0.17
- Peak wavelength: $\lambda = 855 \text{ nm}$
- Material categorization: for definitions of compliance please see www.vishay.com/doc?99912



DESCRIPTION

TS8514VB is a high power infrared, 855 nm surface emitting diode in GaAlAs technology with high radiant power and high speed. Polarity configuration is “n-up”.

GENERAL INFORMATION

The datasheet is based on Vishay optoelectronics sample testing under certain predetermined and assumed conditions, and is provided for illustration purpose only. Customers are encouraged to perform testing in actual proposed packaged and used conditions. Vishay optoelectronics die products are tested using Vishay optoelectronics based quality assurance procedures and are manufactured using Vishay optoelectronics established processes. Estimates such as those described and set forth in this datasheet for semiconductor die will vary depending on a number of packaging, handling, use, and other factors. Therefore sold die may not perform on an equivalent basis to standard package products.

PRODUCT SUMMARY

COMPONENT	ϕ_e (mW)	ϕ (deg)	λ_p (nm)	t_r (ns)
TS8514VB	38	60	855	10

Note

- Test condition see table “Basic Characteristics”

ORDERING INFORMATION

ORDERING CODE	PACKAGING	REMARKS	PACKAGE FORM
TS8514VB-SF-F	Wafer sawn on foil	MOQ: 220 000 pcs	Chip

Note

- MOQ: minimum order quantity

ABSOLUTE MAXIMUM RATINGS ($T_{amb} = 25 \text{ }^\circ\text{C}$, unless otherwise specified)

PARAMETER	TEST CONDITION	SYMBOL	VALUE	UNIT
Forward current		I_F	100	mA
Reverse voltage		V_R	5	V
Surge forward current	$t_p/T = 0.1, t_p = 100 \text{ } \mu\text{s}$	I_{FSM}	1	A
Junction temperature		T_j	100	$^\circ\text{C}$
Operating temperature range		T_{amb}	-40 to +100	$^\circ\text{C}$
Storage temperature range chip		T_{stg1}	-40 to +110	$^\circ\text{C}$
Storage temperature range on foil		T_{stg2}	-40 to +40	$^\circ\text{C}$

BASIC CHARACTERISTICS ($T_{amb} = 25\text{ }^{\circ}\text{C}$, unless otherwise specified)						
PARAMETER	TEST CONDITION	SYMBOL	MIN.	TYP.	MAX.	UNIT
Forward voltage	$I_F = 100\text{ mA}$	V_F	-	1.55	-	V
Radiant power ⁽¹⁾	$I_F = 100\text{ mA}$	ϕ_e	-	38	-	mW
Reverse voltage	$I_R = 10\text{ }\mu\text{A}$	V_R	10	-	-	V
Angle of half intensity	$I_F = 100\text{ mA}$	φ	-	60	-	deg
Peak wavelength	$I_F = 100\text{ mA}$	λ_p	840	855	870	nm
Spectral bandwidth	$I_F = 100\text{ mA}$	$\lambda_{0.5}$	-	30	-	nm
Rise time / fall time	$I_F = 100\text{ mA}$	t_r, t_f	-	10	-	ns

Note

(1) The measurements are based on samples of die which are mounted on a TO-18 gold header without resin coating

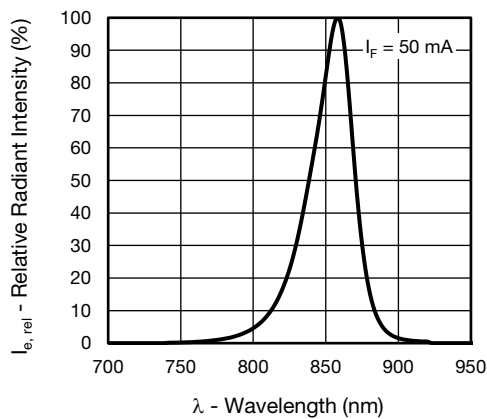
BASIC CHARACTERISTICS ($T_{amb} = 25\text{ }^{\circ}\text{C}$, unless otherwise specified)


Fig. 1 - Relative Spectral Emission
 $\phi_{e,rel} = f(\lambda)$

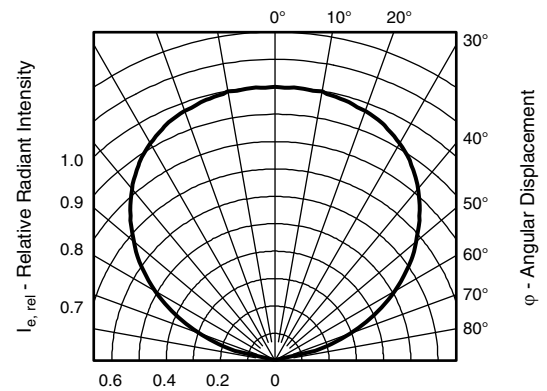


Fig. 2 - Radiant Characteristics
 $I_{rel} = f(\varphi)$

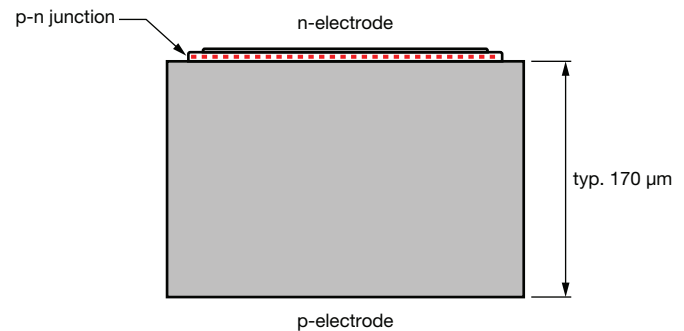
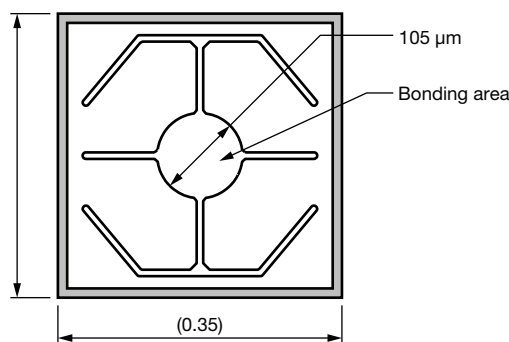
DIMENSIONS


Fig. 3 - Sectional View

MECHANICAL DIMENSIONS					
PARAMETER	SYMBOL	MIN.	TYP.	MAX.	UNIT
Length of chip edge (x-direction)	L_x	-	0.355	-	mm
Length of chip edge (y-direction)	L_y	-	0.355	-	mm
Die height	H	-	0.17	-	mm
Diameter of bondpad	d	-	0.105	-	mm



ADDITIONAL INFORMATION	
Frontside metallization, cathode	Gold alloy
Backside metallization, anode	Gold alloy
Dicing	Sawing
Die bonding technology	Epoxy bonding

Note

- All chips are checked in accordance with the Vishay Semiconductor, specification of visual inspection FVOV6870. The visual inspection shall be made in accordance with the “specification of visual inspection as referenced”. The visual inspection of chip backside is performed with stereo microscope with incident light and 40x to 80x magnification. The quality inspection (final visual inspection) is performed by production. An additional visual inspection step as special release procedure by QM is not installed

HANDLING AND STORAGE CONDITIONS

- The hermetically sealed shipment lots shall be opened in temperature and moisture controlled cleanroom environment only. It is mandatory to follow the rules for disposition of material that can be hazardous for humans and environment
- Product must be handled only at ESD safe workstations. Standard ESD precautions and safe work environments are as defined in MIL-HDBK-263
- Singulated die are not to be handled with tweezers. A vacuum wand with non metallic ESD protected tip should be used

PACKING

Chips are fixed on adhesive foil. Upon request the foils can be mounted on plastic frame or disco frame. For shipment, the wafers are arranged to stacks and hermetically sealed in plastic bags to ensure protection against environmental influence (humidity and contamination).

Use for recycling reliable operators only. We can help getting in touch with your nearest sales office. By agreement we will take back packing material, if it is sorted. You will have to bear the costs of transport. We will invoice you for any costs incurred for packing material that is returned unsorted or which we are not obliged to accept.



Disclaimer

ALL PRODUCT, PRODUCT SPECIFICATIONS AND DATA ARE SUBJECT TO CHANGE WITHOUT NOTICE TO IMPROVE RELIABILITY, FUNCTION OR DESIGN OR OTHERWISE.

Vishay Intertechnology, Inc., its affiliates, agents, and employees, and all persons acting on its or their behalf (collectively, "Vishay"), disclaim any and all liability for any errors, inaccuracies or incompleteness contained in any datasheet or in any other disclosure relating to any product.

Vishay makes no warranty, representation or guarantee regarding the suitability of the products for any particular purpose or the continuing production of any product. To the maximum extent permitted by applicable law, Vishay disclaims (i) any and all liability arising out of the application or use of any product, (ii) any and all liability, including without limitation special, consequential or incidental damages, and (iii) any and all implied warranties, including warranties of fitness for particular purpose, non-infringement and merchantability.

Statements regarding the suitability of products for certain types of applications are based on Vishay's knowledge of typical requirements that are often placed on Vishay products in generic applications. Such statements are not binding statements about the suitability of products for a particular application. It is the customer's responsibility to validate that a particular product with the properties described in the product specification is suitable for use in a particular application. Parameters provided in datasheets and / or specifications may vary in different applications and performance may vary over time. All operating parameters, including typical parameters, must be validated for each customer application by the customer's technical experts. Product specifications do not expand or otherwise modify Vishay's terms and conditions of purchase, including but not limited to the warranty expressed therein.

Except as expressly indicated in writing, Vishay products are not designed for use in medical, life-saving, or life-sustaining applications or for any other application in which the failure of the Vishay product could result in personal injury or death. Customers using or selling Vishay products not expressly indicated for use in such applications do so at their own risk. Please contact authorized Vishay personnel to obtain written terms and conditions regarding products designed for such applications.

No license, express or implied, by estoppel or otherwise, to any intellectual property rights is granted by this document or by any conduct of Vishay. Product names and markings noted herein may be trademarks of their respective owners.