

PRODUCT NUMBER
SEE TABLE

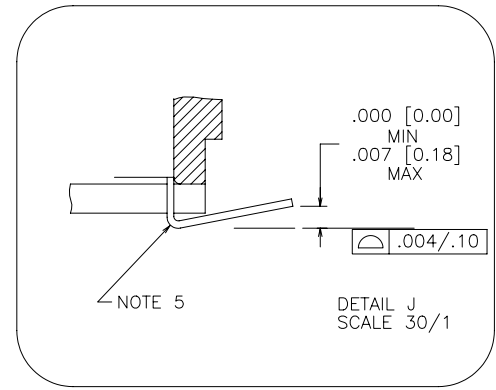

mat'l. code		surface		tolerance		projection		product family		
-		ISO 1302		ISO 406 ISO 1101				RIB CAGE		
ltr	ecn no	dr	date	tolerances unless otherwise specified						
AA	M05-0123	MHT	6/06/05	angles	linear	$XX \pm .01 / XX \pm 0.3$ $XXX \pm .005 / XXX \pm 0.13$ $XXXX \pm .0020 / XXX \pm 0.051$		title		
AB	M06-0284	AEA	7/27/06					.050cc VERT. SMT.		
AC	M08-0053	CMR	2/27/08	$\sigma \pm 2'$		INCH/MM scale 1:1		W/LOC. & POL. FEATURE		
AD	M09-0058	CMR	4/06/09	dr	M. CLOUSER	6/26/91		dwg no		
AE	M09-0071	MHT	4/30/09	enr	B. BARUFFALO	6/26/91		sheet 1 of 3		
AF	N10-0174	YOH	6/17/10	chr	B. BARUFFALO	6/26/91		size		
				appd	B. BARUFFALO	6/26/91		type		
sheet		revision		AF	AF	AF				
index		sheet		1	2	3				

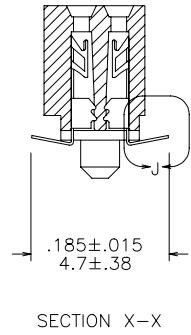
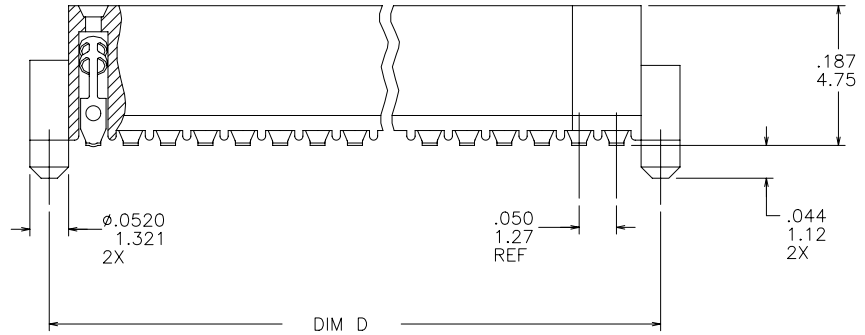
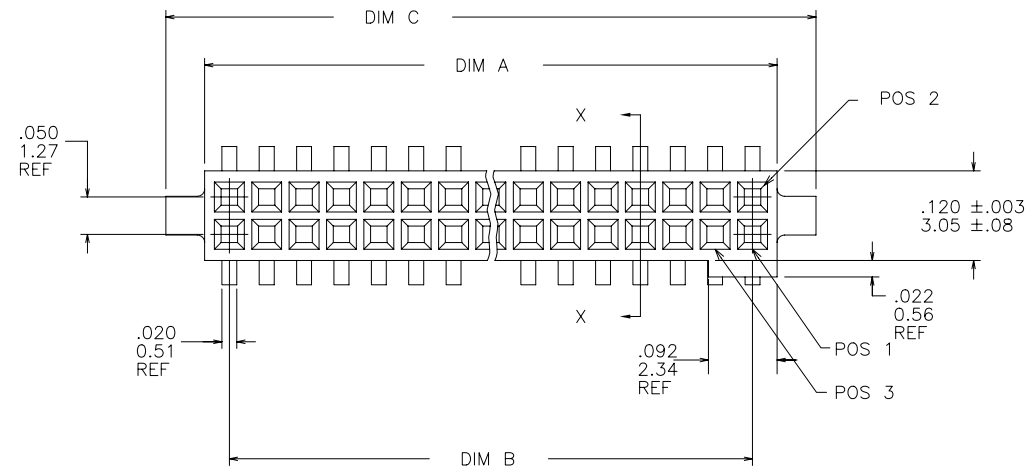

Copyright FCI

PRODUCT NO. NOTE 9	SIZE	DIM A	DIM B	DIM C	DIM D	SPECIAL PACKAGING	TAPE WIDTH PITCH	PIECES PER REEL
87024-605	2 X 5	.266/6.756	.200/5.08	.370/9.398	.3200/8.128	NOTE 6	24mm 12mm	750
-610	2 X 10	.516/13.106	.450/11.43	.620/15.748	.5700/14.478	NOTE 6	24mm 12mm	750
-610P	2 X 10	.516/13.106	.450/11.43	.620/15.748	.5700/14.478	NOTE 8	24mm 16mm	400
-615	2 X 15	.766/19.456	.700/17.78	.870/22.098	.8200/20.828	NOTE 6	44mm 12mm	500
-620	2 X 20	1.016/25.806	.950/24.13	1.120/28.448	1.0700/27.178	NOTE 6 & 7	44mm 12mm	500
-625	2 X 25	1.266/32.156	1.200/30.48	1.370/34.798	1.3200/33.528	NOTE 6	56mm 12mm	500
-630	2 X 30	1.516/38.506	1.450/36.83	1.620/41.148	1.5700/39.878	NOTE 6 & 7	56mm 12mm	500
-635	2 X 35	1.766/44.856	1.700/43.18	1.870/47.498	1.8200/46.228	NOTE 6	72mm 12mm	500
-640	2 X 40	2.016/51.206	1.950/49.53	2.120/53.848	2.0700/52.578	NOTE 6 & 7	72mm 12mm	500
-645	2 X 45	2.266/57.556	2.200/55.88	2.370/60.198	2.3200/58.928	NOTE 6	72mm 12mm	500
87024-650	2 X 50	2.516/63.906	2.450/62.23	2.620/66.548	2.5700/65.278	NOTE 6 & 7	88mm 12mm	500

NOTES:

- ① HOUSING MATERIAL:
LCP GLASS FILLED FLAME RETARDANT PER UL 94V-0
COLOR: NATURAL
- ② TERMINAL MATERIAL: BeCu
- ③ TERMINAL PLATING:
30u"/.76um MIN HARD GOLD OVER Ni ON CONTACT ZONES,
100u"/2.54um MIN TIN OVER Ni IN SOLDERING ZONES,
OTHERWISE GOLD FLASH OR UNPLATED.
- 4 APPLICATION INFORMATION:
A. RECOMMENDED MOUNTING PAD PATTERN IS
SHOWN IN FIGURE "A".
B. MATING PINS TO BE .0176/.447 TO .0181/.459 DIA.
C. MATING PIN TIPS TO BE IN TRUE POSITION TO MATING
GRID WITHIN .006/.15 DIA.
D. SUGGESTED MATING PIN LENGTH .130/3.30
±.010/.25.
- ⑤ LEAD TIPS TO BE ABOVE HEEL, UP TO .007/0.18 MAX.
COPLANARITY TO BE MEASURED AT LOWEST POINT (HEEL).
- ⑥ ADD "TR" TO END OF DASH NUMBER FOR TAPE AND
REEL PACKAGING WITH CAP.
TOOLED ONLY FOR NOTED CONNECTORS.
- ⑦ ADD "CT" TO END OF DASH NUMBER FOR CONNECTOR WITH CAP FOR
VACUUM PICKUP IN TUBE.
- ⑧ CUSTOMER SPECIAL, TAPE AND REEL PACKAGING, TOOLED
ONLY FOR NOTED CONNECTOR.
- ⑨ ADD "LF" SUFFIX AT THE END OF PART NUMBER FOR LEAD FREE OPTION.
10. IF LF P/N THE PRODUCT MEETS EUROPEAN UNION DIRECTIVES AND OTHER
COUNTRY REGULATION AS DESCRIBED IN GS-22-008.
11. THE HOUSING WILL WITHSTAND EXPOSURE TO 260°C PEAK TEMPERATURE
FOR 20 SECONDS IN A CONVECTION, INFRA-RED OR VAPOR PHASE REFLOW
OVEN. SEE APPLICATION NOTES/PROCEDURES IF THEY ARE AVAILABLE.

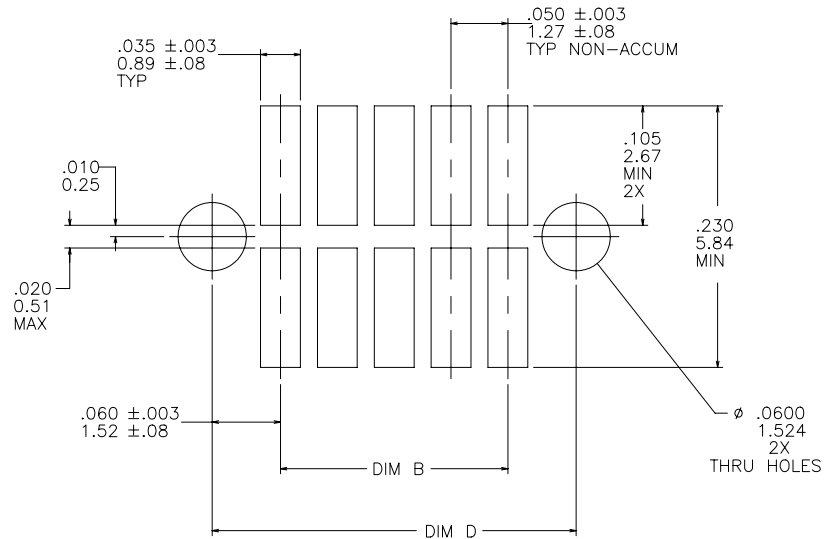

FIGURE A
RECOMMENDED
P.C.B. LAYOUT

mat'l. code		surface		tolerance	projection	product family	
-		ISO 1302		ISO 406 ISO 1101		RIB CAGE	
ltr	ecn no	dr	date	tolerances unless otherwise specified		title	
AF				angles	linear	.050cc VERT. SMT. W/LOC. & POL. FEATURE	
				0°±2'	XXX±.01/XX±0.3 XXX±.005/XX±0.13 XXX±.0020/XX±0.051	INCH/MM	
				dr	M. CLOUSER	6/26/91	scale 1:1
				enrg	B. BARUFFALO	6/26/91	
				chr	B. BARUFFALO	6/26/91	
				appd	B. BARUFFALO	6/26/91	
sheet	revision						sheet 2 of 3
index	sheet						
						size A3	
						type Product Customer Drawing	

REFERENCE ONLY

TAPE WIDTH'S 32mm AND ABOVE HAS BOTH FEED TRACKS,
BELOW 32mm HAS TOP FEED TRACK ONLY.

UNREELING
DIRECTION

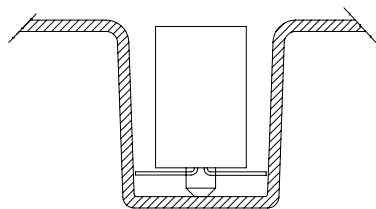
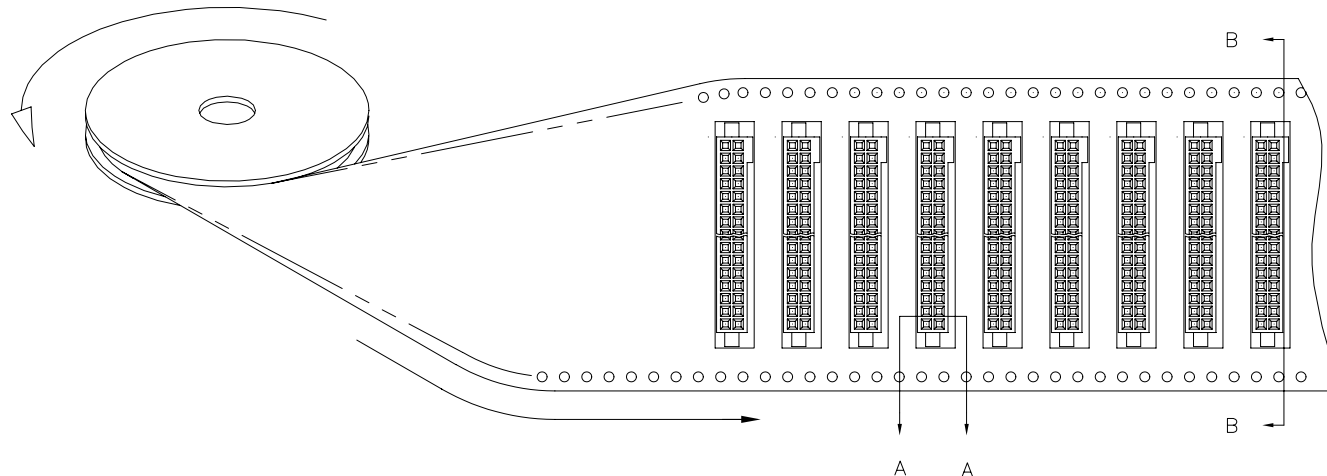

SECTION A-A

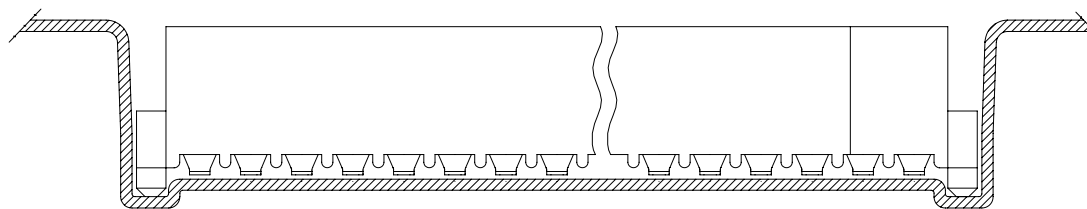

SECTION B-B

mat'l. code		surface		tolerance		projection		product family	
-		ISO 1302		ISO 406 ISO 1101				RIB CAGE	
ltr	ecn no	dr	date	tolerances unless otherwise specified					
AF				angles	linear	$XX \pm .01 / XX \pm 0.3$ $XXX \pm .005 / XXX \pm 0.13$ $XXXX \pm .0020 / XXX \pm 0.051$		title	
				$0^\circ \pm 2'$		INCH/MM		.050cc VERT. SMT. W/LOC. & POL. FEATURE	
				dr	M. CLOUSER	6/26/91	scale 1:1		dwg no
				engr	B. BARUFFALO	6/26/91			sheet 3 of 3
				chr	B. BARUFFALO	6/26/91	87024		size
				appd	B. BARUFFALO	6/26/91	type		A3
sheet		revision		product customer drawing					
index		sheet							