

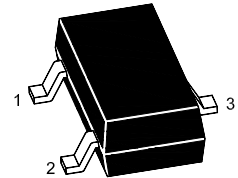

### Features

- For Switching and AF Amplifier Applications.
- Silicon Epitaxial Chip.

**SOT-23**  
**(TO-236)**



1.Base 2.Emitter 3.Collector

### Absolute Maximum Ratings ( $T_A = 25^\circ\text{C}$ )

Parameter	Symbol	Value	Unit
Collector Base Voltage	$V_{CB0}$	60	V
Collector Emitter Voltage	$V_{CEO}$	40	V
Emitter Base Voltage	$V_{EB0}$	6	V
Collector Current	$I_C$	200	mA
Power Dissipation	$P_D$	350	mW
Junction Temperature	$T_J$	150	$^\circ\text{C}$
Storage Temperature Range	$T_{STG}$	- 55 to + 150	$^\circ\text{C}$



### Electrical Characteristics at $T_A = 25^\circ\text{C}$

Parameter	Symbol	Min.	Max.	Unit
DC Current Gain				
at $V_{CE} = 1\text{ V}$ , $I_C = 0.1\text{ mA}$	$h_{FE}$	40	-	-
at $V_{CE} = 1\text{ V}$ , $I_C = 1\text{ mA}$	$h_{FE}$	70	-	-
at $V_{CE} = 1\text{ V}$ , $I_C = 10\text{ mA}$	$h_{FE}$	100	300	-
at $V_{CE} = 1\text{ V}$ , $I_C = 50\text{ mA}$	$h_{FE}$	60	-	-
at $V_{CE} = 1\text{ V}$ , $I_C = 100\text{ mA}$	$h_{FE}$	30	-	-
Collector Base Cutoff Current at $V_{CB} = 30\text{ V}$	$I_{CBO}$	-	50	nA
Emitter Base Cutoff Current at $V_{EB} = 6\text{ V}$	$I_{EBO}$	-	50	nA
Collector Base Breakdown Voltage at $I_C = 10\text{ }\mu\text{A}$	$V_{(BR)CBO}$	60	-	V
Collector Emitter Breakdown Voltage at $I_C = 1\text{ mA}$	$V_{(BR)CEO}$	40	-	V
Emitter Base Breakdown Voltage at $I_E = 10\text{ }\mu\text{A}$	$V_{(BR)EBO}$	6	-	V
Collector Emitter Saturation Voltage at $I_C = 10\text{ mA}$ , $I_B = 1\text{ mA}$	$V_{CE(sat)}$	-	0.2	V
at $I_C = 50\text{ mA}$ , $I_B = 5\text{ mA}$	$V_{CE(sat)}$	-	0.3	V
Base Emitter Saturation Voltage at $I_C = 10\text{ mA}$ , $I_B = 1\text{ mA}$	$V_{BE(sat)}$	0.65	0.85	V
at $I_C = 50\text{ mA}$ , $I_B = 5\text{ mA}$	$V_{BE(sat)}$	-	0.95	V
Current Gain Bandwidth Product at $V_{CE} = 20\text{ V}$ , $I_C = 10\text{ mA}$ , $f = 100\text{ MHz}$	$f_T$	300	-	MHz
Collector Output Capacitance at $V_{CB} = 5\text{ V}$ , $I_E = 0$ , $f = 1\text{ MHz}$	$C_{ob}$	-	4	pF
Delay Time at $V_{CC} = 3\text{ V}$ , $V_{BE} = 0.5\text{ V}$ , $I_C = 10\text{ mA}$ , $I_{B1} = 1\text{ mA}$	$t_d$	-	35	ns
Rise Time at $V_{CC} = 3\text{ V}$ , $V_{BE} = 0.5\text{ V}$ , $I_C = 10\text{ mA}$ , $I_{B1} = 1\text{ mA}$	$t_r$	-	35	ns
Storage Time at $V_{CC} = 3\text{ V}$ , $I_C = 10\text{ mA}$ , $I_{B1} = -I_{B2} = 1\text{ mA}$	$t_s$	-	200	ns
Fall Time at $V_{CC} = 3\text{ V}$ , $I_C = 10\text{ mA}$ , $I_{B1} = -I_{B2} = 1\text{ mA}$	$t_f$	-	50	ns



### Electrical Characteristics Curves

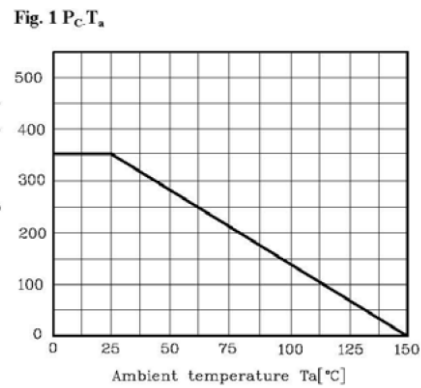
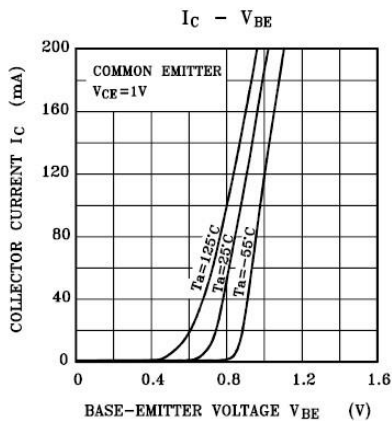
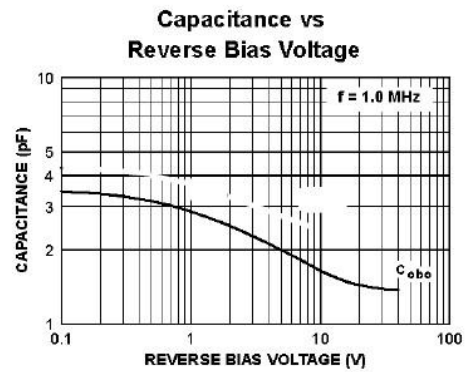
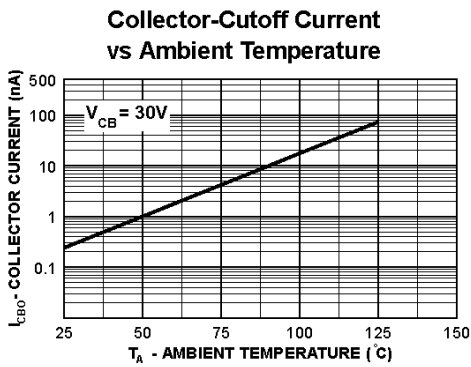
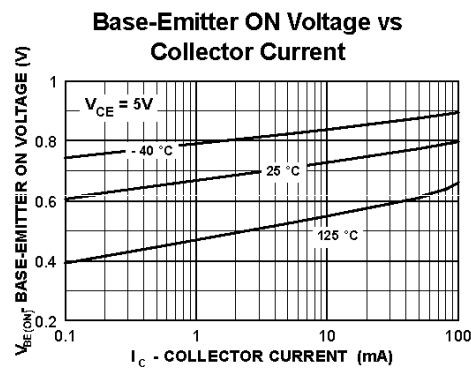
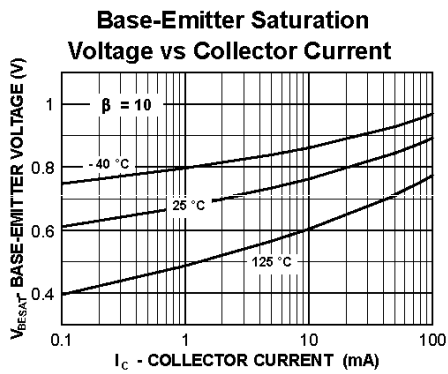
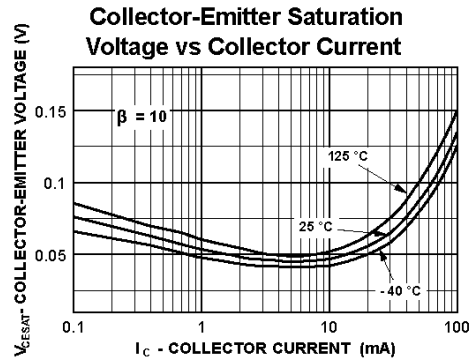
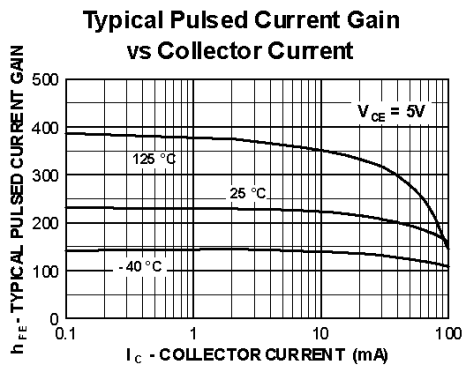



### Package Outline (SOT-23)

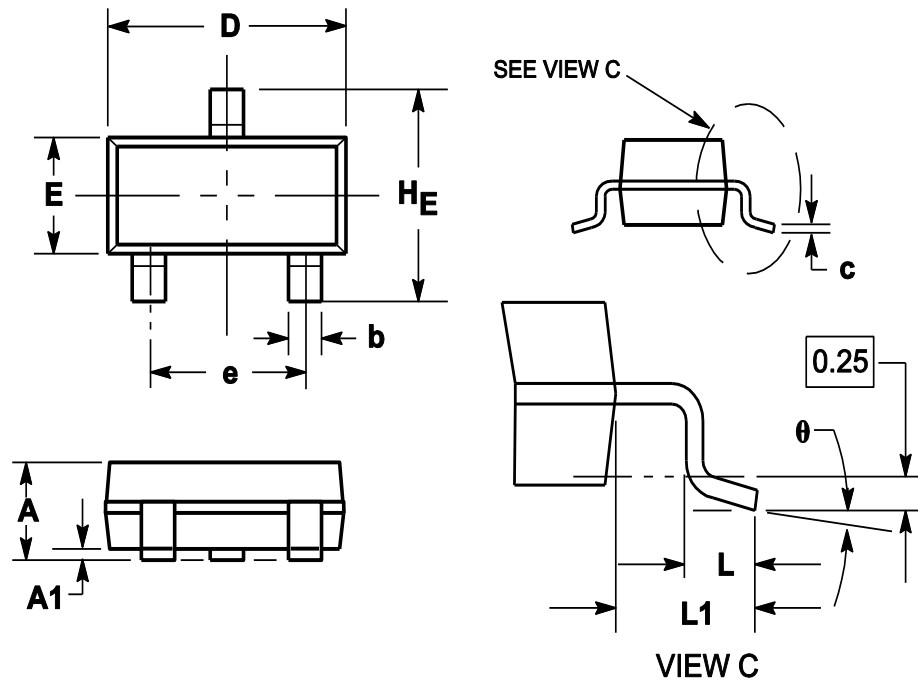

Symbol	Dimensions in millimeter		
	Min.	Typ.	Max.
A	0.900	1.025	1.150
A1	0.000	0.050	0.100
b	0.300	0.400	0.500
c	0.080	0.115	0.150
D	2.800	2.900	3.000
E	1.200	1.300	1.400
HE	2.250	2.400	2.550
e	1.800	1.900	2.000
L1	0.550REF		
L	0.300		0.500
θ	0°		8°

### Ordering Information

Device	Package	Reel Dimension (inch)	Shipping Quantity
MMBT3904	SOT-23	7	3,000