

66281

Transistor Output Bulkhead Optocoupler



03/31/2008

Features:

- High reliability
- Base lead provided for conventional transistor biasing
- Fully shielded circuit
- Hermetically sealed for reliability and stability
- Stability over wide temperature range
- Available with attached wires
- 500 Volt electrical isolation

Applications:

- Line Receivers
- Switchmode Power Supplies
- Signal ground isolation
- Process Control input/output isolation

DESCRIPTION

The 66281 Optocoupler consists of an 880nm GaAlAs LED optically coupled to a silicon phototransistor. Packaged in a hermetically sealed metal case and mounted to a bulk head housing. Available as screened, unscreened or tested to customer specifications and with or without wires.

ABSOLUTE MAXIMUM RATINGS

Input to Output Voltage	500 V
Collector-Base Voltage	45 V
Collector-Emitter Voltage (See Note 1)	40 V
Emitter-Base Voltage	7 V
Input Diode Reverse Voltage	2 V
Input Diode Continuous Forward Current at (or below) 65°C Free-Air Temperature (see note 2)	40 mA
Continuous Collector Current	50 mA
Peak Diode Current (See Note 3)	1 A
Continuous Transistor Power Dissipation at (or below) 25°C Free-Air Temperature (see Note 4)	300 mW
Operating Free-Air Temperature Range	-55°C to +125°C
Storage Temperature	-65°C to +150°C
Lead Temperature (1/16" (1.6mm) from case for 10 seconds)	240°C

Notes:

1. This value applies with the emitter-base diode open-circuited and the input-diode current equal to zero.
2. Derate linearly to 125°C free-air temperature at the rate of 0.67 mW/°C.
3. This value applies for $t_w \leq 1$ us. PRR < 300 pps.
4. Derate linearly to 125°C free-air temperature at the rate of 3 mW/°C.

Package Dimensions

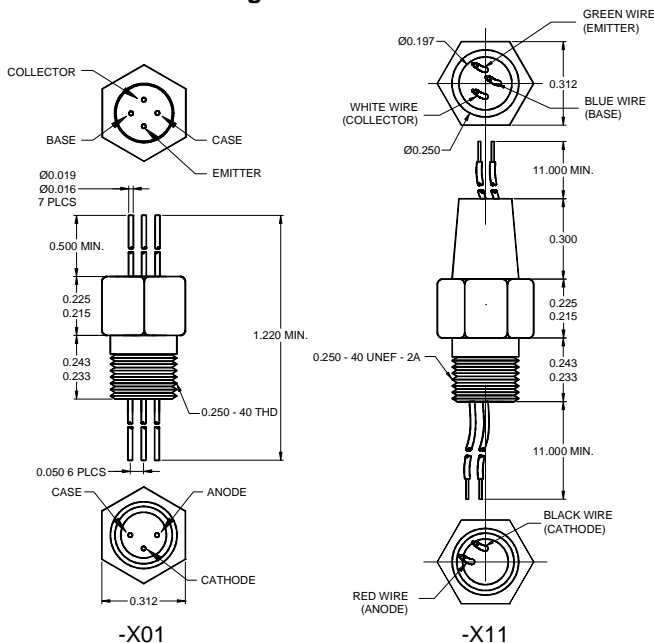

Schematic Diagram

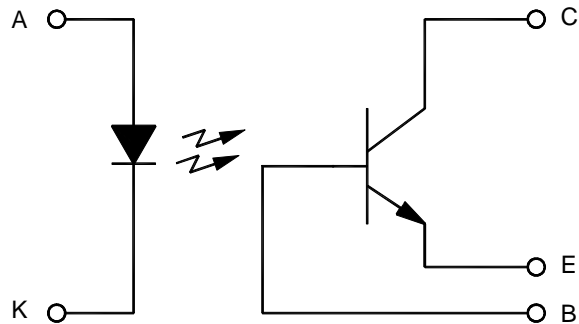

NOTE: ALL WIRES ARE 26 AWG WITH TEFLON INSULATION.

66281

03/31/2008

Transistor Output Bulkhead Optocoupler**INPUT DIODE CHARACTERISTICS** $T_A = 25^\circ\text{C}$ unless otherwise specified.

PARAMETER	SYMBOL	MIN	MAX	UNITS	TEST CONDITIONS
Input Diode Static Reverse Current	I_R		100	μA	$V_R = 2\text{ V}$
Input Diode Static Forward Voltage	V_F	0.8	1.5	V	$I_F = 10\text{ mA}$

OUTPUT TRANSISTOR CHARACTERISTICS $T_A = 25^\circ\text{C}$ unless otherwise noted

PARAMETER	SYMBOL	MIN	MAX	UNITS	TEST CONDITIONS
Collector-Base Breakdown Voltage	$V_{(BR)CBO}$	45		V	$I_C = 100\ \mu\text{A}$, $I_E = 0$, $I_F = 0$
Collector-Emitter Breakdown Voltage	$V_{(BR)CEO}$	40		V	$I_C = 1\text{ mA}$, $I_B = 0$, $I_F = 0$
Emitter-Base Breakdown Voltage	$V_{(BR)EBO}$	7		V	$I_C = 0\text{ mA}$, $I_E = 100\ \mu\text{A}$, $I_F = 0$
Off-State Collector Current	I_{CEO}		100	nA	$V_{CE} = 20\text{ V}$

COUPLED CHARACTERISTICS $T_A = 25^\circ\text{C}$ unless otherwise noted

PARAMETER	SYMBOL	MIN	MAX	UNITS	TEST CONDITIONS
Current Transfer Ratio	$I_{C(ON)}$	1		mA	$V_{CE} = 5\text{ V}$, $I_F = 1\text{ mA}$
Collector-Emitter Saturation Voltage	$V_{CE(SAT)}$		0.3	V	$I_F = 2\text{ mA}$, $I_C = 1\text{ mA}$
Input-Output Isolation Voltage	V_{I-O}	500		V	$I_{I-O} = 100\text{ nA}$
Rise Time	t_r		20	μs	$V_{CC} = 10\text{ V}$, $I_F = 10\text{ mA}$, $R_L = 100\ \Omega$
Fall Time	t_f		20	μs	$V_{CC} = 10\text{ V}$, $I_F = 10\text{ mA}$, $R_L = 100\ \Omega$

RECOMMENDED OPERATING CONDITIONS:

PARAMETER	SYMBOL	MIN	MAX	UNITS
Input Current, Low Level	I_{FL}	0	10	μA
Input Current, High Level	I_{FH}	1	20	mA
Operating Temperature	T_A	-55	100	$^\circ\text{C}$

SELECTION GUIDE

PART NUMBER	PART DESCRIPTION
66281-001	Commercial
66281-101	Screened
66281-011	Commercial with wires
66281-101	Screened with wires