

Space-saving Plug-in Signal Conditioners H-UNIT

DC ALARM

Functions & Features

- Providing relay contact closures at preset DC input levels
- Single or dual (Hi/Lo) trip
- Multi-turn screwdriver setpoint adjustments
- Enclosed relays
- Relays can be powered 110 V DC
- High-density mounting

Typical Applications

- Annunciator
- Various alarm applications

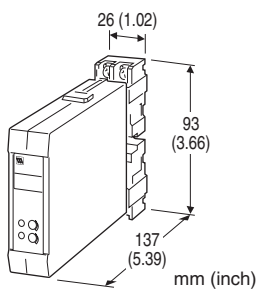

MODEL: HAS-[1][2]-R[3]

ORDERING INFORMATION

- Code number: HAS-[1][2]-R[3]
- Specify a code from below for each of [1] through [3].
(e.g. HAS-62-R/Q)
- Special input range (For code 0)
 - Specify the specification for option code /Q
(e.g. /C01/S01)
- Use Ordering Information Sheet (No. ESU-1033) to specify output code 0 specifications.

[1] INPUT

Current

- A: 4 - 20 mA DC (Input resistance 250 Ω)
- D: 0 - 20 mA DC (Input resistance 50 Ω)
- G: 0 - 1 mA DC (Input resistance 1000 Ω)
- H: 10 - 50 mA DC (Input resistance 100 Ω)

Voltage

- 3: 0 - 1 V DC (Input resistance 1 M Ω min.)
- 4: 0 - 10 V DC (Input resistance 1 M Ω min.)
- 5: 0 - 5 V DC (Input resistance 1 M Ω min.)
- 6: 1 - 5 V DC (Input resistance 1 M Ω min.)
- 0: Specify voltage (See INPUT SPECIFICATIONS)

[2] OUTPUT

- 1: Single (SPDT); Hi in power failure
- 2: Single (SPDT); Lo in power failure
- 5: Hi/Lo (N.O.); OFF in power failure
- 6: Hi/Lo (N.C.); OFF in power failure
- 0: Specify

POWER INPUT

DC Power

- R: 24 V DC
(Operational voltage range 24 V \pm 10 %, ripple 10 %p-p max.)

[3] OPTIONS

- blank: none
- /Q: With options (specify the specification)

SPECIFICATIONS OF OPTION: Q (multiple selections)

COATING (For the detail, refer to M-System's web site.)

- /C01: Silicone coating
- /C02: Polyurethane coating
- /C03: Rubber coating

TERMINAL SCREW MATERIAL

- /S01: Stainless steel

GENERAL SPECIFICATIONS

- Construction:** Plug-in
- Connection:** M3.5 screw terminals (torque 0.8 N·m)
- Screw terminal:** Nickel-plated steel (standard) or stainless steel
- Housing material:** Flame-resistant resin (black)
- Isolation:** Input to output to power
- Setpoint adjustments:** Multi-turn screwdriver adjustments (front); -5 - +105 % independently
- Hysteresis (deadband):** Approx. 1 %
- Front LEDs:** Red LED turns on when the coil is energized.
- Power ON timer:** Relays de-energized for approx. 2 seconds after power is turned on.

INPUT SPECIFICATIONS

- **DC Current:**
Shunt resistor attached to the input terminals (0.5 W)
- **DC Voltage:** 0 - 300 V DC
- Minimum span:** 1 V
- Offset:** Max. 1.5 times span
- Input resistance:** \geq 1 M Ω

OUTPUT SPECIFICATIONS

■ **Relay Contact:** 100 V AC @ 1 A ($\cos \vartheta = 1$)

120 V AC @ 1 A ($\cos \vartheta = 1$)

240 V AC @ 0.5 A ($\cos \vartheta = 1$)

30 V DC @ 1 A (resistive load)

Maximum switching voltage: 380 V AC or 125 V DC

Maximum switching power: 120 VA or 30 W

Minimum load: 5 V DC @ 10 mA

Mechanical life: 5×10^7 cycles

For maximum relay life with inductive loads, external protection is recommended.

Insulation resistance: $\geq 100 \text{ M}\Omega$ with 500 V DC

Dielectric strength: 500 V AC @ 1 minute
(input to output to power)

1500 V AC @ 1 minute (input or output or power to ground)

Alarm Trip Operation Terminal No. in parentheses

• **Output Code : 1, 2**

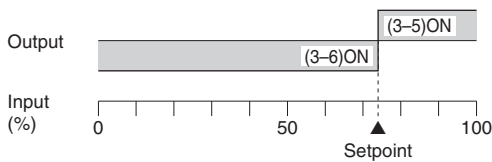

• **Output Code : 5**

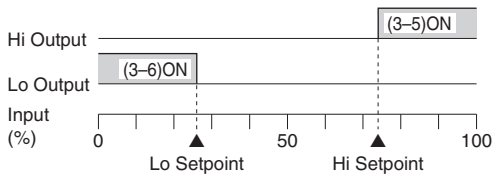

• **Output Code : 6**

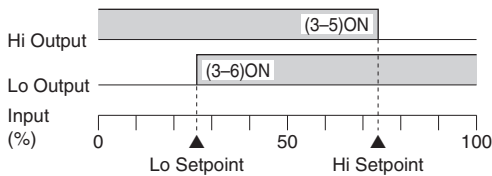

Trip Operation in Power Failure

- **Output Code 1:** Terminals 3 – 5 turn ON
- **Output Code 2:** Terminals 3 – 6 turn ON
- **Output Code 5, 6:** both relays turn OFF

INSTALLATION

Current consumption: Approx. 40 mA

Operating temperature: -5 to +55°C (23 to 131°F)

Operating humidity: 30 to 90 %RH (non-condensing)

Mounting: Surface or DIN rail; Standard Rack Mounting

Frame BX-16H available

Weight: 180 g (0.40 lb)

PERFORMANCE in percentage of span

Trip point repeatability: $\pm 0.1 \%$

Temp. coefficient: $\pm 0.015 \%/^{\circ}\text{C}$ ($\pm 0.008 \%/^{\circ}\text{F}$)

Response time: Approx. 0.5 sec. (0 – 100 % at 90 % setpoint)

Line voltage effect: $\pm 0.1 \%$ over voltage range

EXTERNAL VIEW

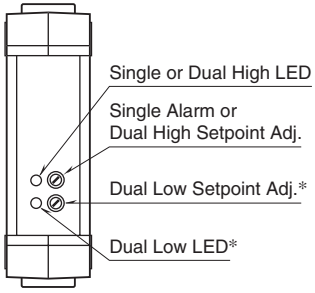

*Not provided for Single Alarm.

EXTERNAL DIMENSIONS unit: mm (inch)

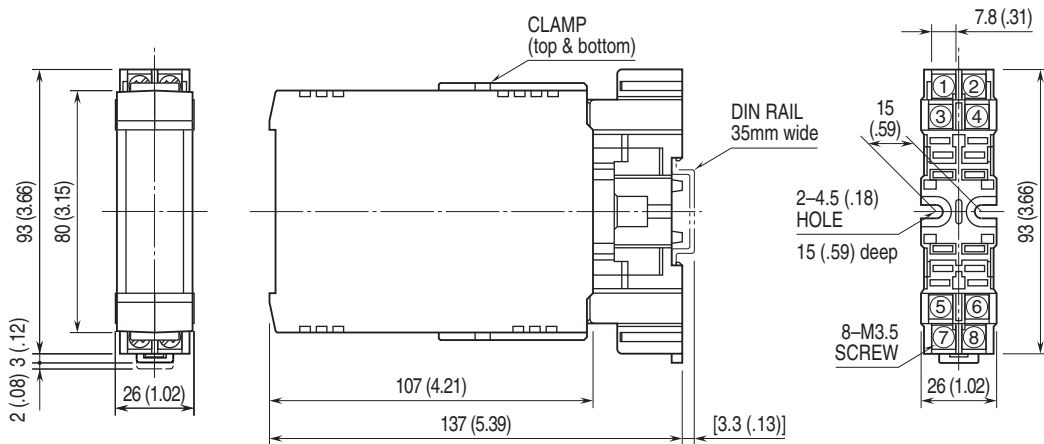

•When mounting, no extra space is needed between units.

TERMINAL ASSIGNMENTS unit: mm (inch)

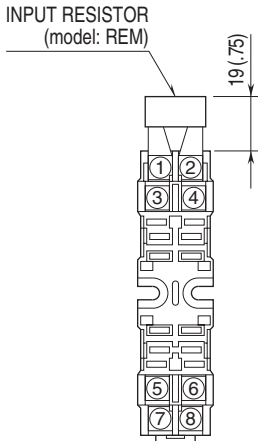

Input shunt resistor attached for current input.

SCHEMATIC CIRCUITRY & CONNECTION DIAGRAM

■ SINGLE ALARM

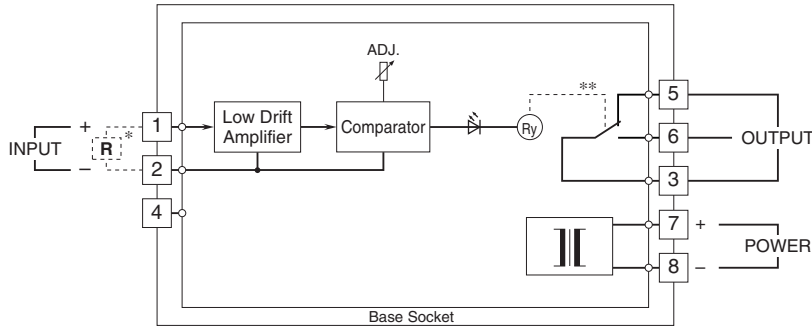

* Input shunt resistor attached for current input.
 **Relay status is determined by output codes.

■ Relay Protection

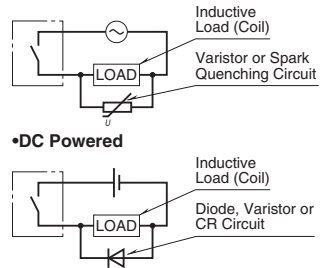

■ DUAL ALARM

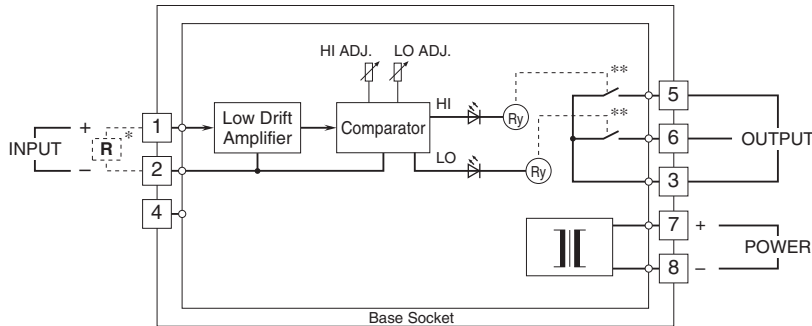

* Input shunt resistor attached for current input.
 **Relay status is determined by output codes.



Specifications are subject to change without notice.