

DETAILS

Product Number	C13605_HB-2X2-RW
Family	HighBay
Type	Lens array
Color	clear
Diameter	50x50 mm
Height	8,5 mm
Style	square
Optic Material	PMMA
Holder Material	
Fastening	glue, screw, pin
Status	production ready
ROHS Compliant	Yes
Date Updated	21/04/2016



OPTICAL PROPERTIES

LED	Viewing Angle	Light Beam	Efficiency	cd/lm	Connector
XT-E	44 deg	Wide	91 %	1.600	-
XP-G2	48 deg	Wide	91 %	1.400	-
XP-G	50 deg	Wide	89 %	1.300	-
XP-E	51 deg	Wide	89 %	1.400	-
XB-D	46 deg	Wide	88 %	1.600	-
NCSxx19A	49 deg	Wide	90 %	1.500	-
NVSxx19A	52 deg	Wide	88 %	1.300	-
NVSxx19B/NVSxx19C	51 deg	Wide	90 %	1.300	-
NVSxE21A	37 deg	Wide	84 %	1.600	-
Oslon Square PC	50 deg	Wide	90 %	1.400	-
Oslon SSL 80	46 deg	Wide	90 %	1.700	-
Oslon Square Gen3	49 deg	Wide	89 %	1.300	-
PrevaLED Brick DC 2x8	49 deg	Wide	89 %	1.300	-
LH351Z	48 deg	Wide	90 %	1.400	-
Z5M1/Z5M2	49 deg	Wide	90 %	1.400	-
Z8Y15	46 deg	Wide	88 %	1.400	-
Z8Y19	47 deg	Wide	87 %	1.300	-
Z8Y22	45 deg	Wide	93 %	1.200	-
TL1L4	47 deg	Wide	83 %	1.300	-
RLE G1 49x223mm 4000lm xxx EXC OT	5 deg	Wide	94 %	1.400	-
RLE G1 49x245mm 4000lm xxx EXC OT	5 deg	Wide	94 %	1.400	-
RLE G1 49x121mm 2000lm xxx EXC OT	5 deg	Wide	94 %	1.400	-
RLE G1 49x133mm 2000lm xxx EXC OT	5 deg	Wide	94 %	1.400	-

D

C

B

A

4

4

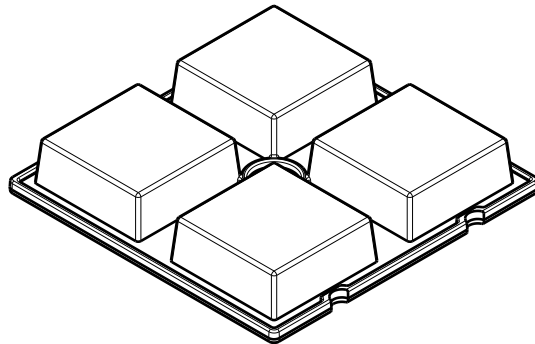
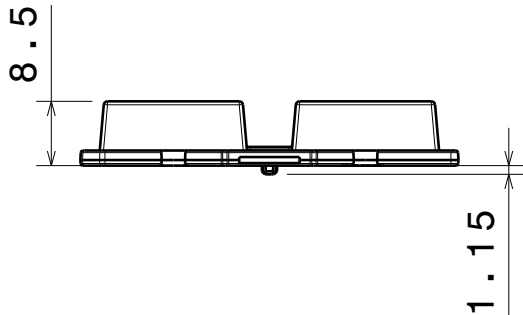

3

3

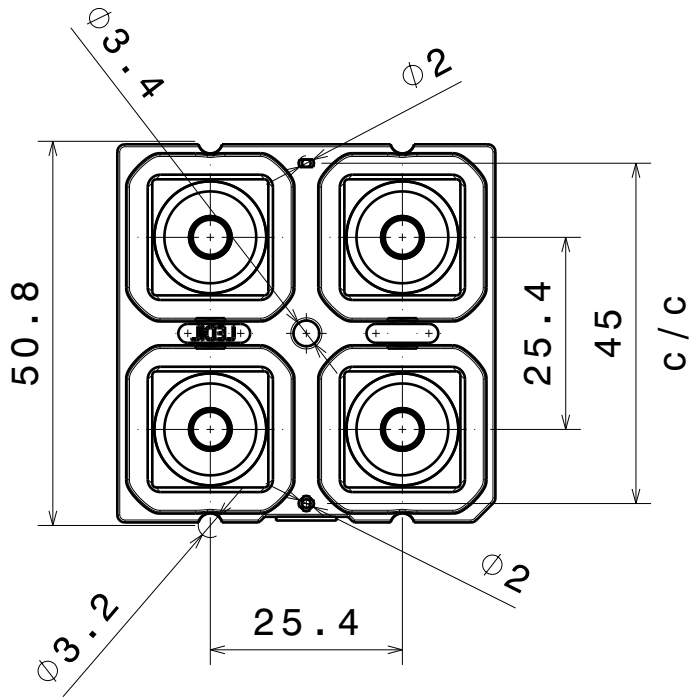
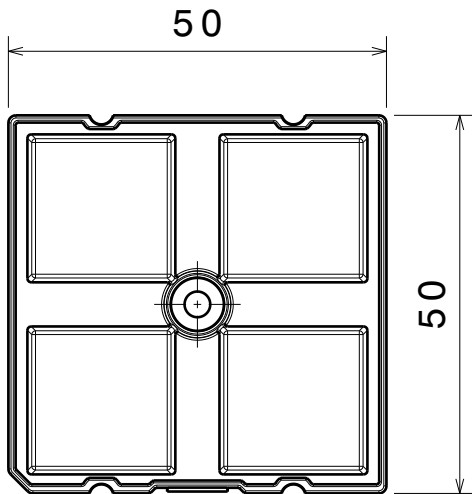

2

2

INDEX	PART NO	DESCRIPTION	MATERIAL	COLOUR
1	C13605	HB-2x2-RW	PMMA	

Tolerances if not otherwise shown
 According to DIN ISO 2768-1
 Linear measures:
 up to 30mm class M, otherwise class C
 According to DIN ISO 2768-2
 Form and position: class L

LEDiL

Ledil Oy
 Salorankatu 10
 FIN 24240 SALO
 Finland

THIRD ANGLE PROJECTION:

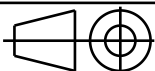

DRAWING TITLE

C13605_HB-2x2-RW

This drawing is the property
 of LEDiL Oy. It may not be
 reproduced, copied or
 communicated without a written
 agreement with LEDiL Oy.

SIZE PART NUMBER

A4

C13605

SCALE 1:1 WEIGHT 10,6 g SHEET 1/1

D

A

1

1

Luminaire: Ledil Oy C13605_HB-2X2-RW (Cree XT-E 390lm @ 250mA) Efficiency=89%
Lamps: 1 x Cree XT-E 390lm @ 250mA CCT=5717K P=3W I=250mA

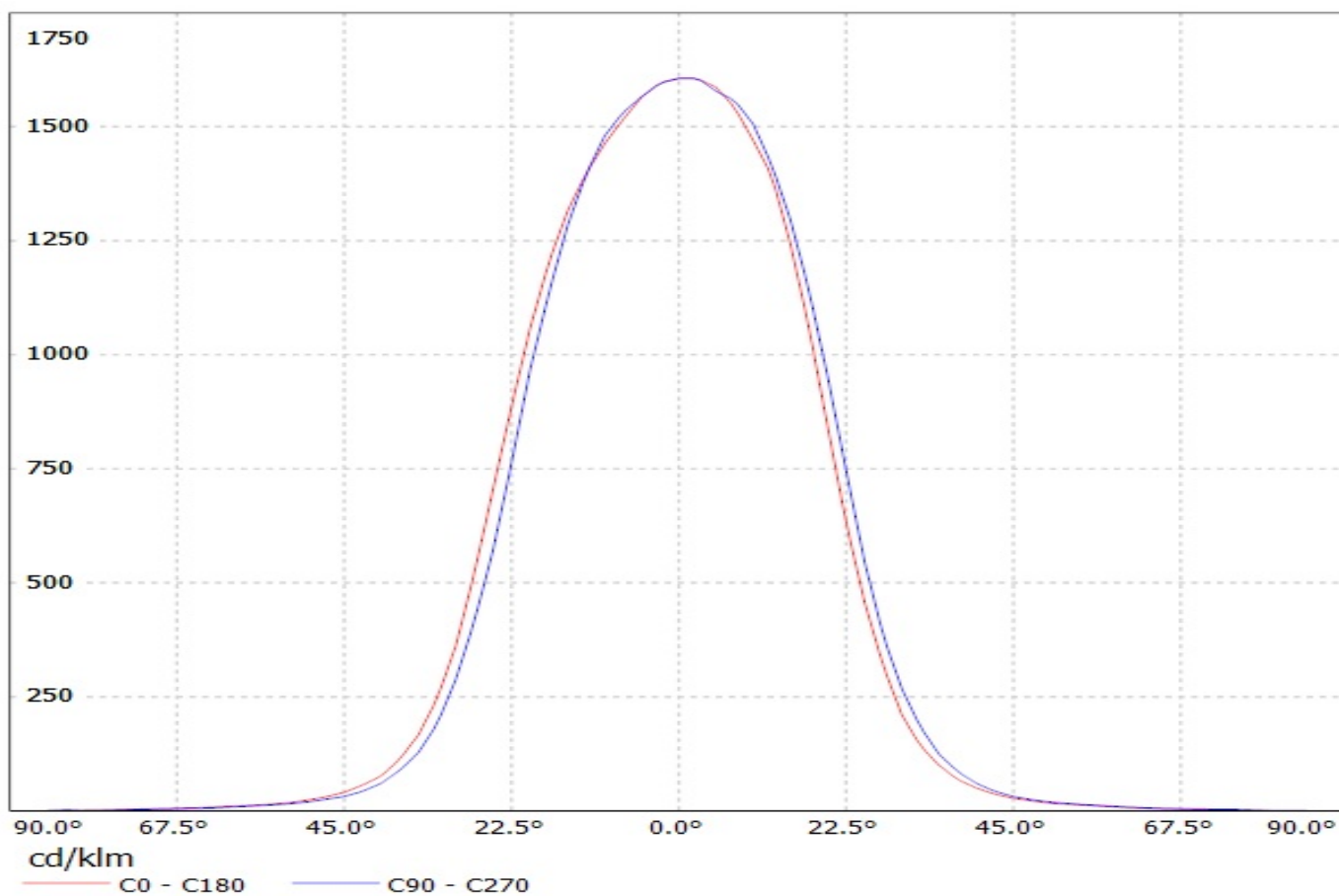

Luminaire: Ledil Oy C13605_HB-2X2-RW (Cree XP-G2 408lm Im @ 250mA) Efficiency=91%
Lamps: 1 x Cree XP-G2 408lm Im @ 250mA CCT=7181K P=3W I=250mA

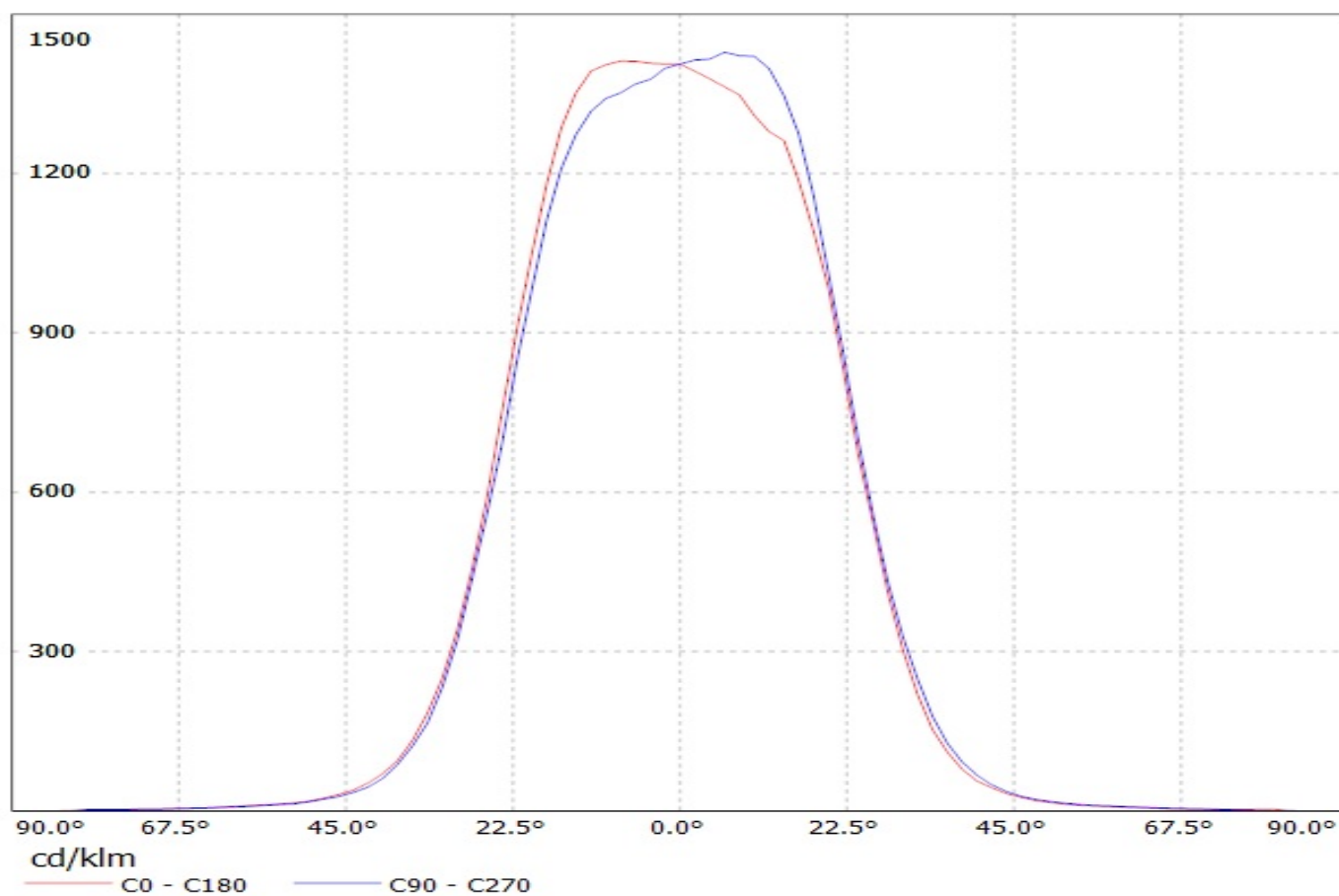

Luminaire: Ledil Oy C13605_HB-2X2-RW_(XP-G) Efficiency=89%
Lamps: 1 x Cree XP-G (254lm @ 250mA) CCT=3300K P=2.9W I=250mA

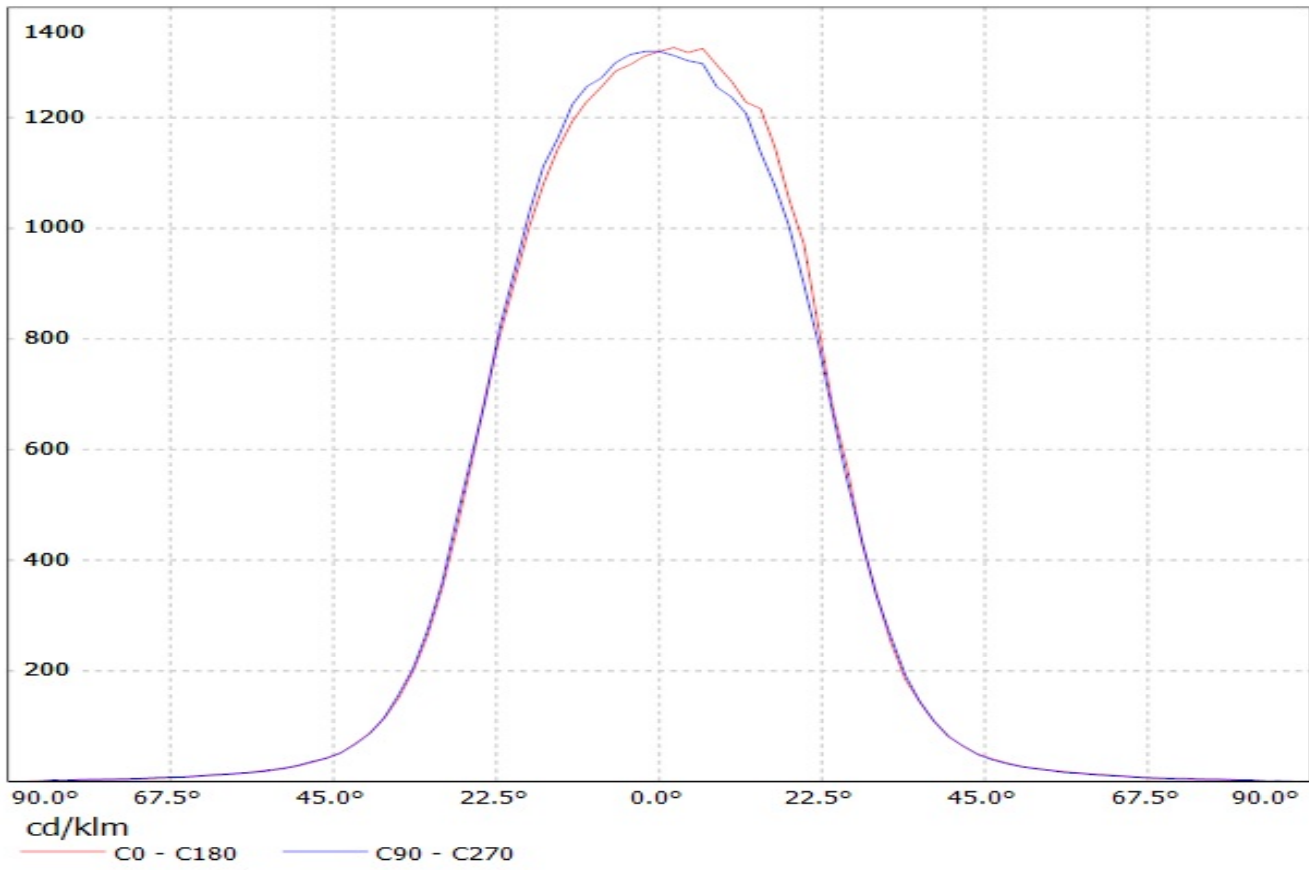

Luminaire: Ledil Oy C13605_HB-2x2-RW_(XP-E) Efficiency=89%
Lamps: 1 x Cree XP-E (XPEWHT-L1-3C0-W5-0-06) 302lm @ 250mA CCT=5400K P=3.1W I=250mA

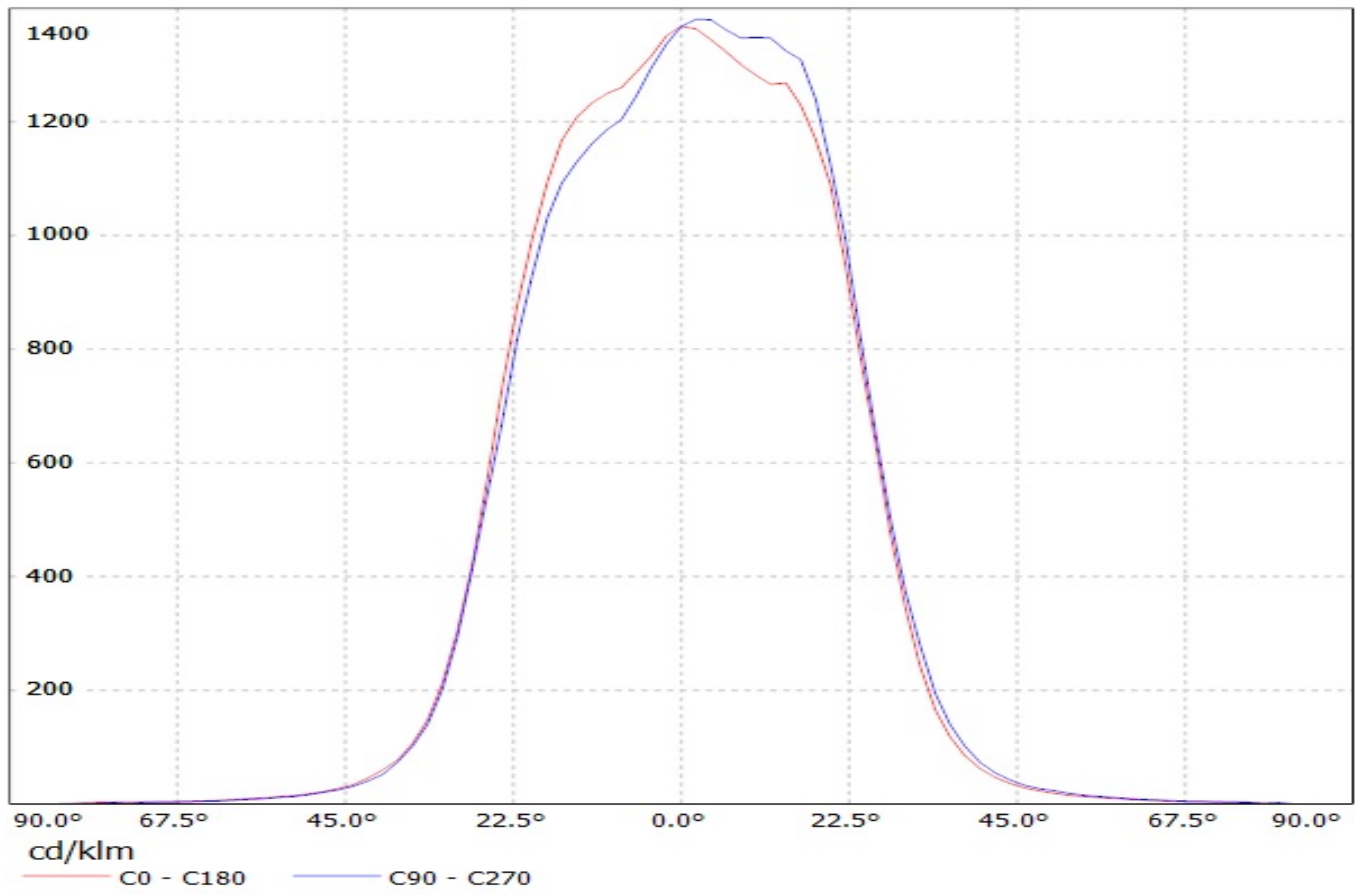

Luminaire: Ledil Oy C13605_HB-2X2-RW_(XB-D) Efficiency=88%
Lamps: 1 x Cree XB-D (365lm @ 250mA) CCT=6800K P=3.1W I=250mA

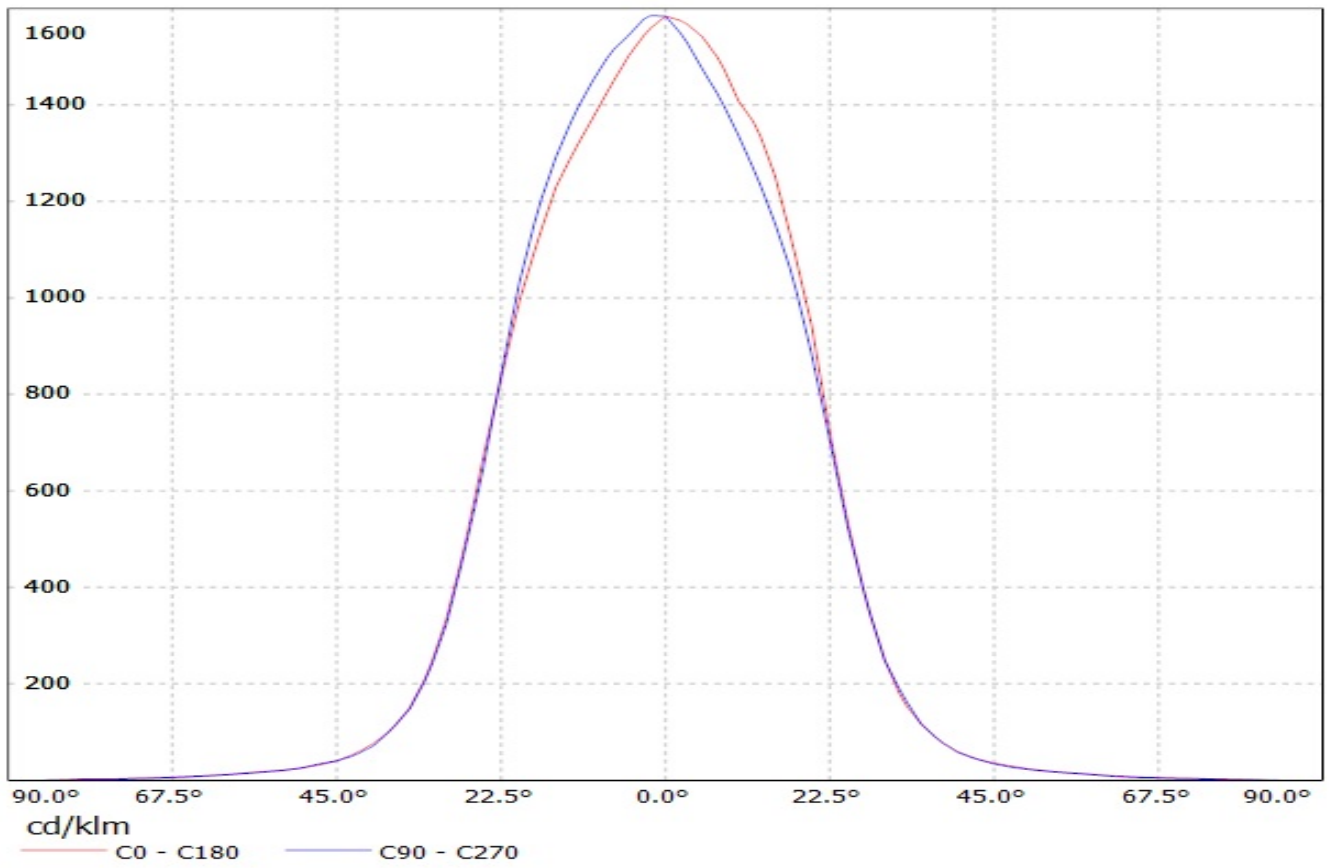

Luminaire: Ledil Oy C13605_HB-2X2-RW_(NCSxx19A) Efficiency=90%
Lamps: 1 x Nichia NCSxx19A (NCSL119AT-H1) (229lm @ 250mA) CCT=2800K P=3.1W I=250mA

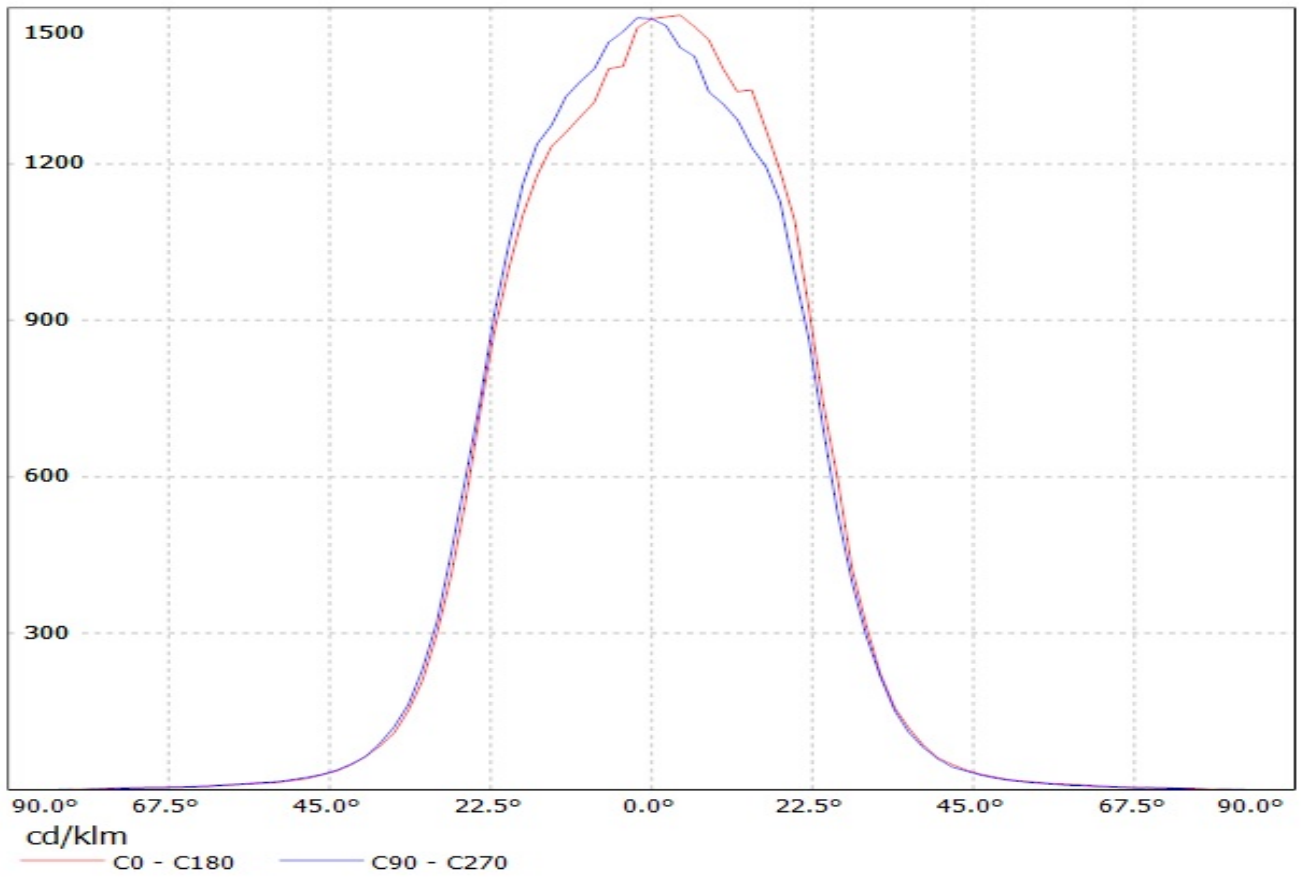

Luminaire: Ledil Oy C13605_HB-2x2-RW_(NVSxx19A) Efficiency=88%
Lamps: 1 x Nichia NVSxx19A (NVS219AT) 382lm @ 250mA CCT=5290K P=2.9W I=250mA

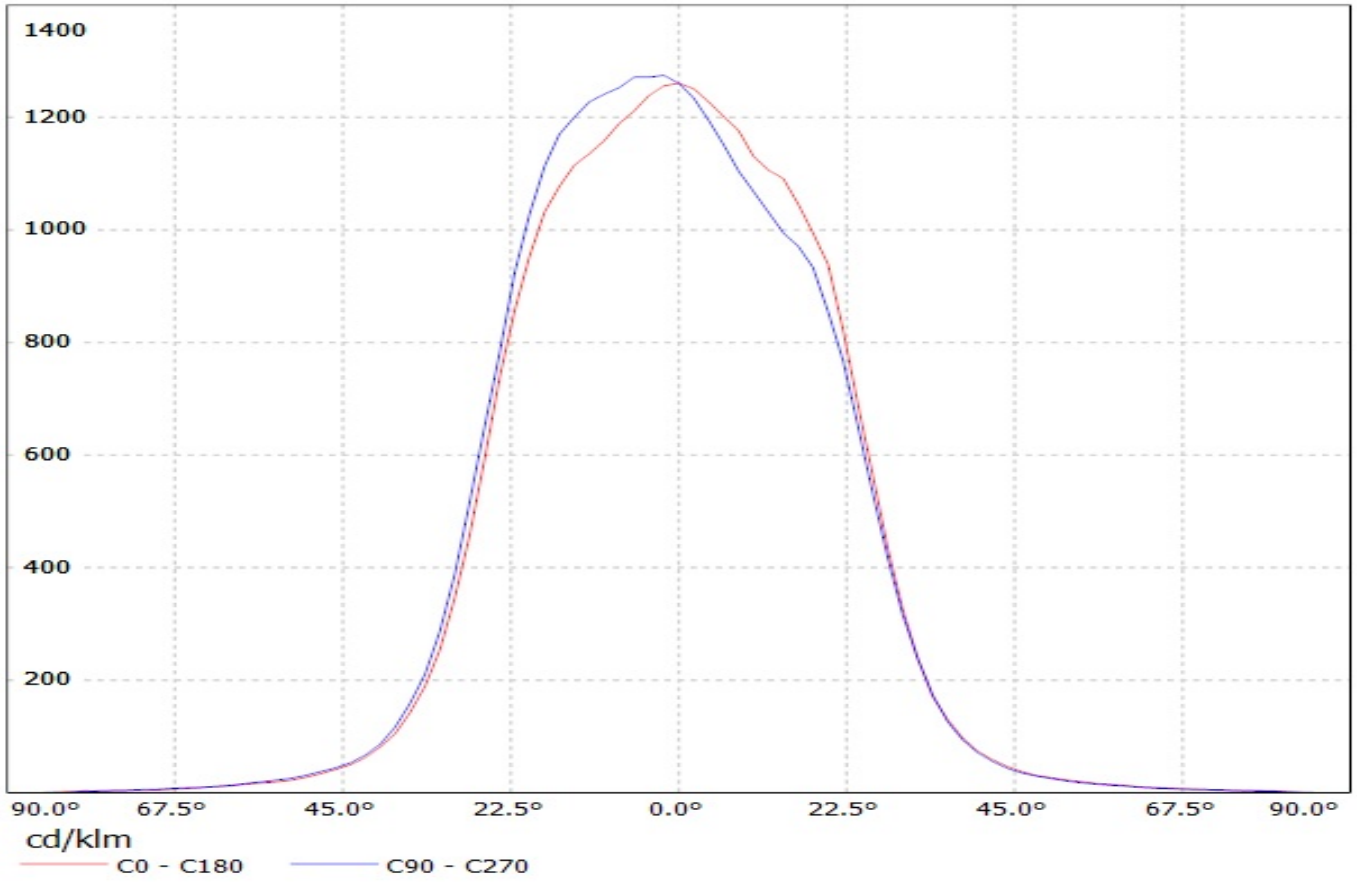

Luminaire: Ledil Oy C13605_HB-2X2-RW_(NVSxx19B) Efficiency=90%
Lamps: 1 x Nichia NVSxx19B (NVSL219BE) 308lm @ 250mA CCT=3100K P=2.9W I=250mA

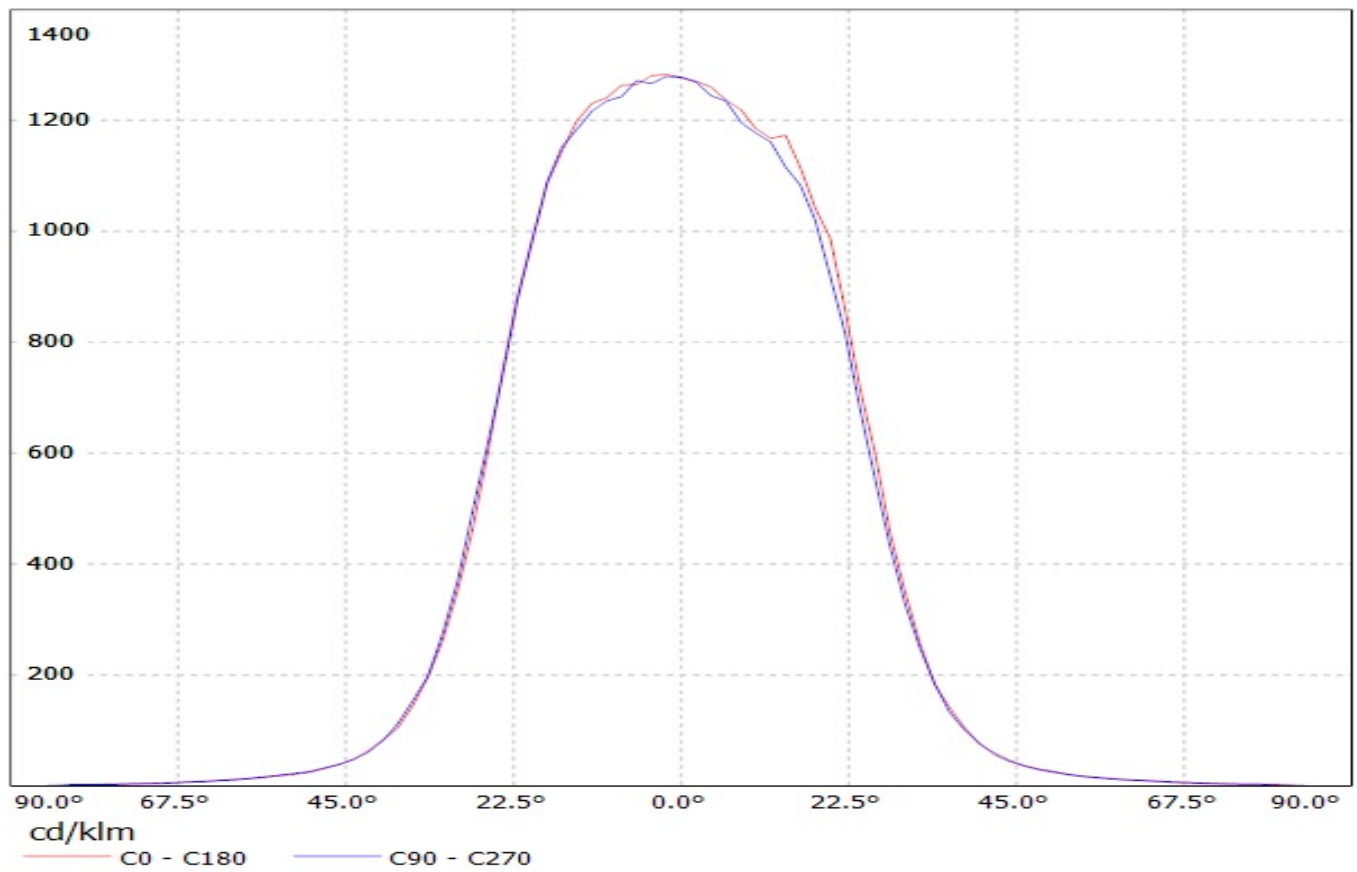

Luminaire: LEDiL Oy C13605_HB-2X2-RW_(E21A)
Lamps: 1 x Nichia_E21A_2X2_454.11lm@250mA_P=2.81W_I=0.250A

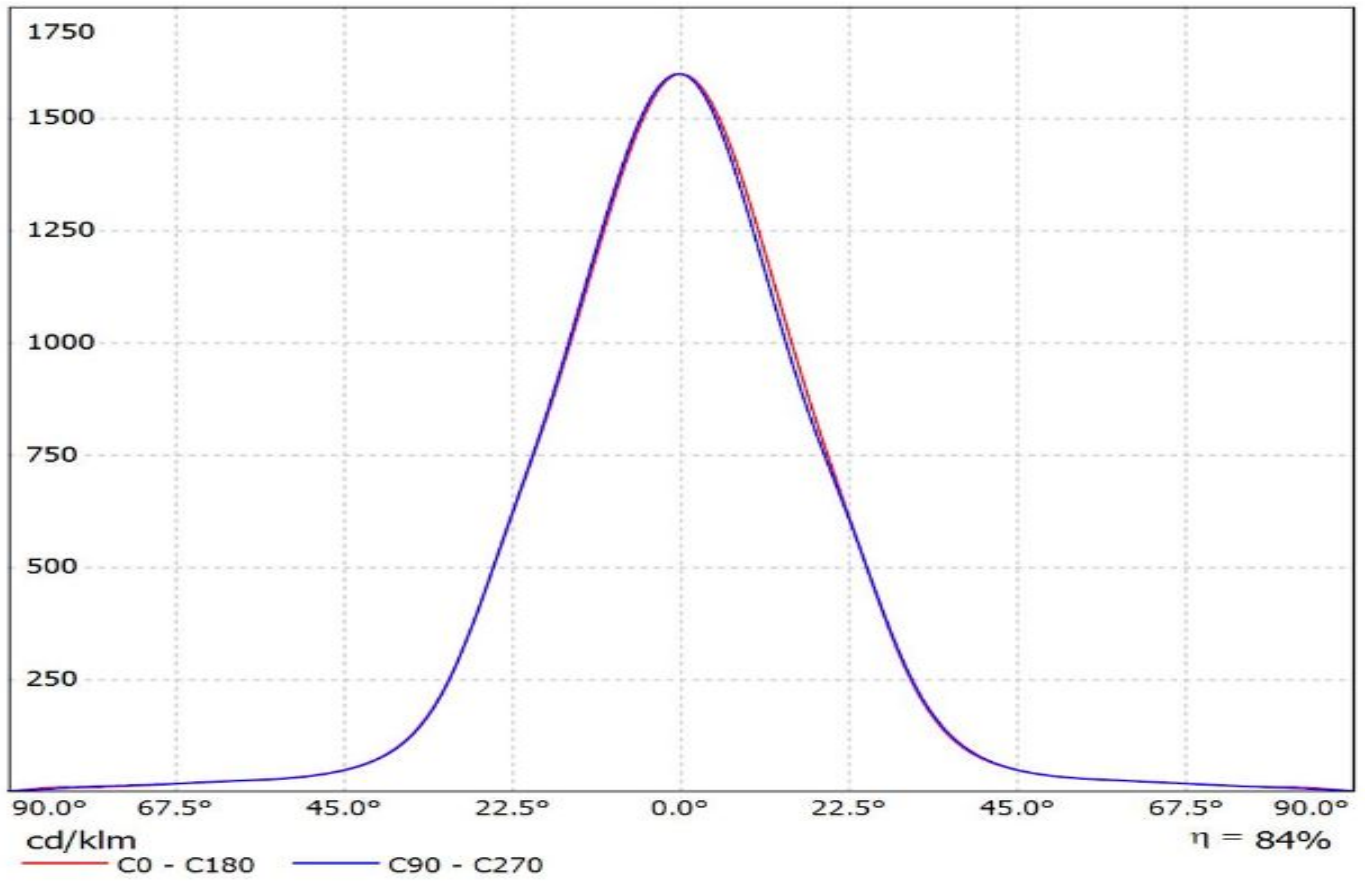

Luminaire: Ledil Oy C13605_HB-2X2-RW_(Oslon_Square_PC) Efficiency=90%
Lamps: 1 x Osram Oslon Square PC (LCW-CQAR.PC-MSMU-5H71-1) 389lm @ 250mA CCT=6000K P=3.0W I=250mA

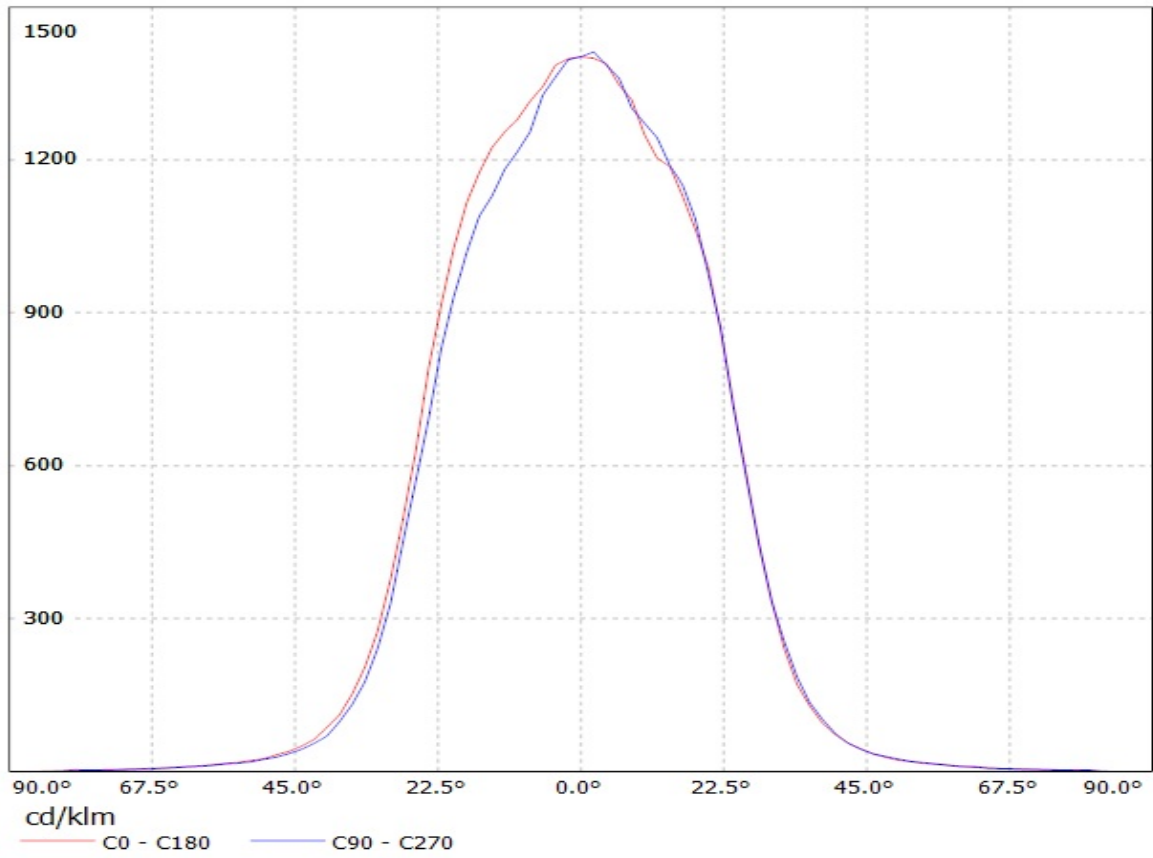

Luminaire: Ledil Oy C13605_HB-2X2-RW_(SSL_80) Efficiency=90%
Lamps: 1 x Osram Oslon SSL 80 (310lm @ 250mA) CCT=6800K P=3.2W I=250mA

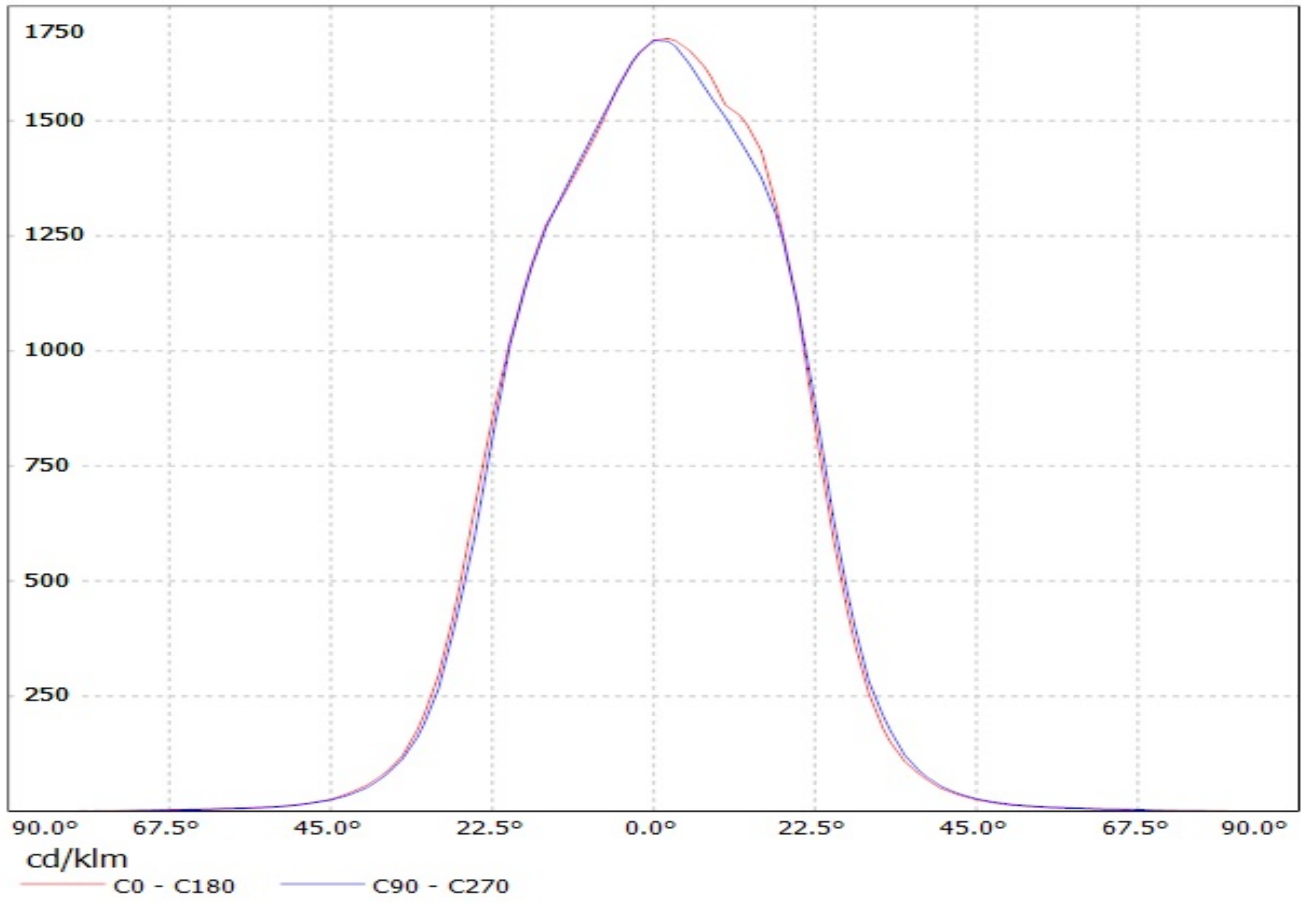

Luminaire: LEDiL Oy
Lamps: 1 x C13605-HB-2x2-RW_(SQ_Gen3)

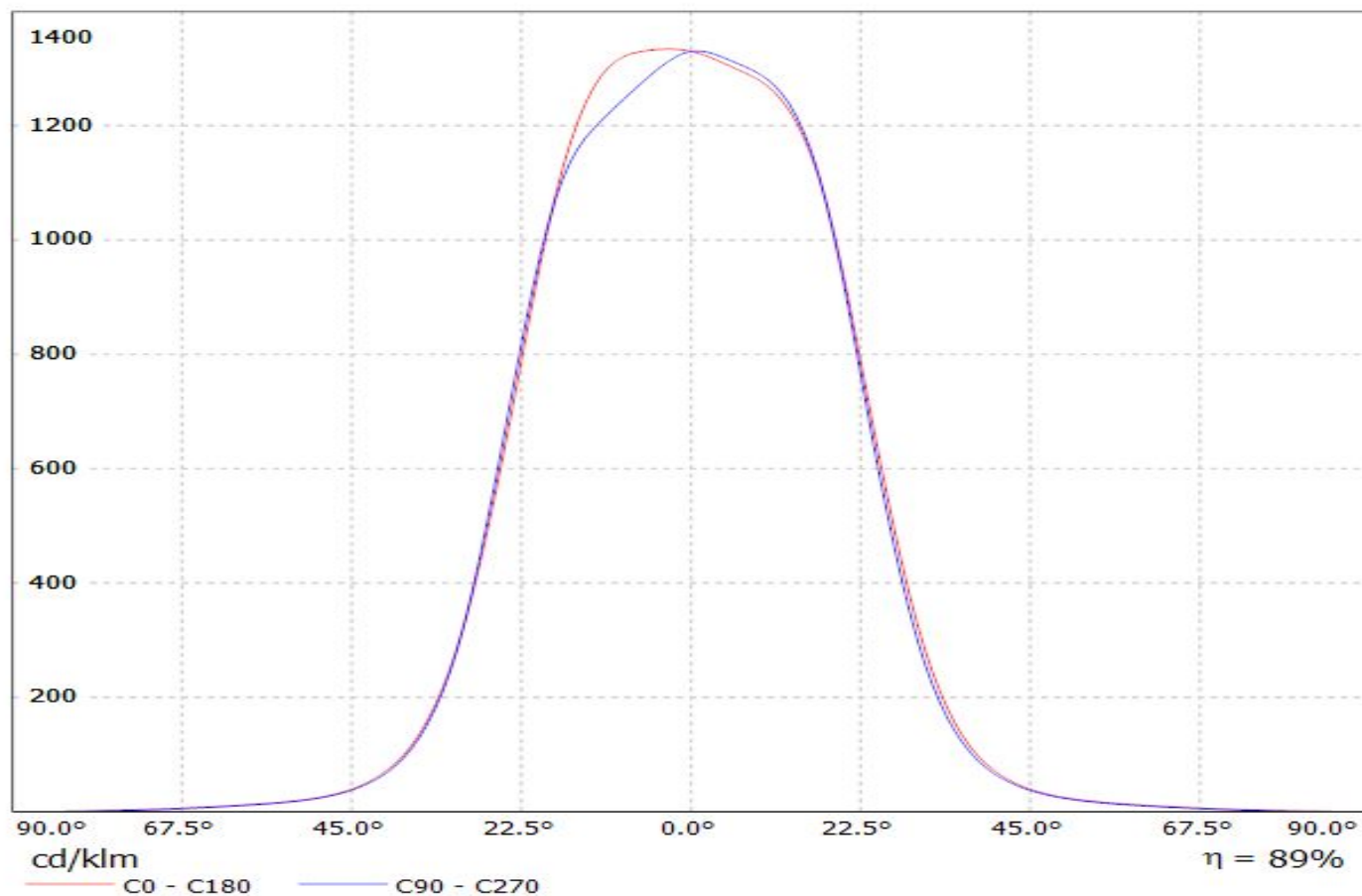

Luminaire: LEDiL Oy C13605_HB-2X2-RW_(LH351Z) Eff.90.2%
Lamps: 1 x SAMSUNG_LH351Z_2x2_359.49lm@250mA_P=2.86371W_I=249.8mA

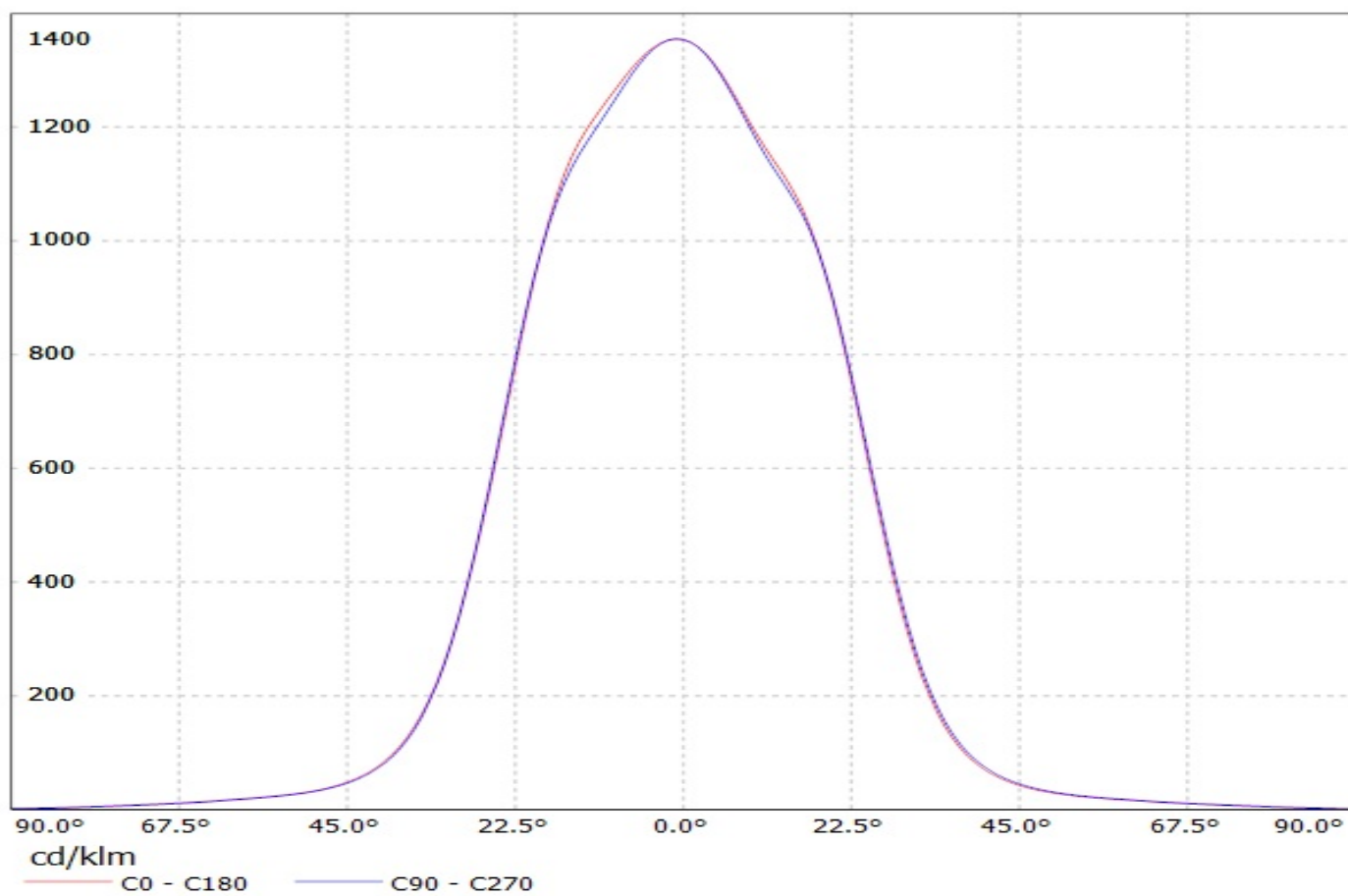

Luminaire: LEDil Oy C13605_HB-2x2-RW_(Z5M1) Efficiency=90%
Lamps: 1 x Seoul (SZ5-M1-WN-C8) 379lm @ 250mA CCT=4600K P=2.9W I=250mA

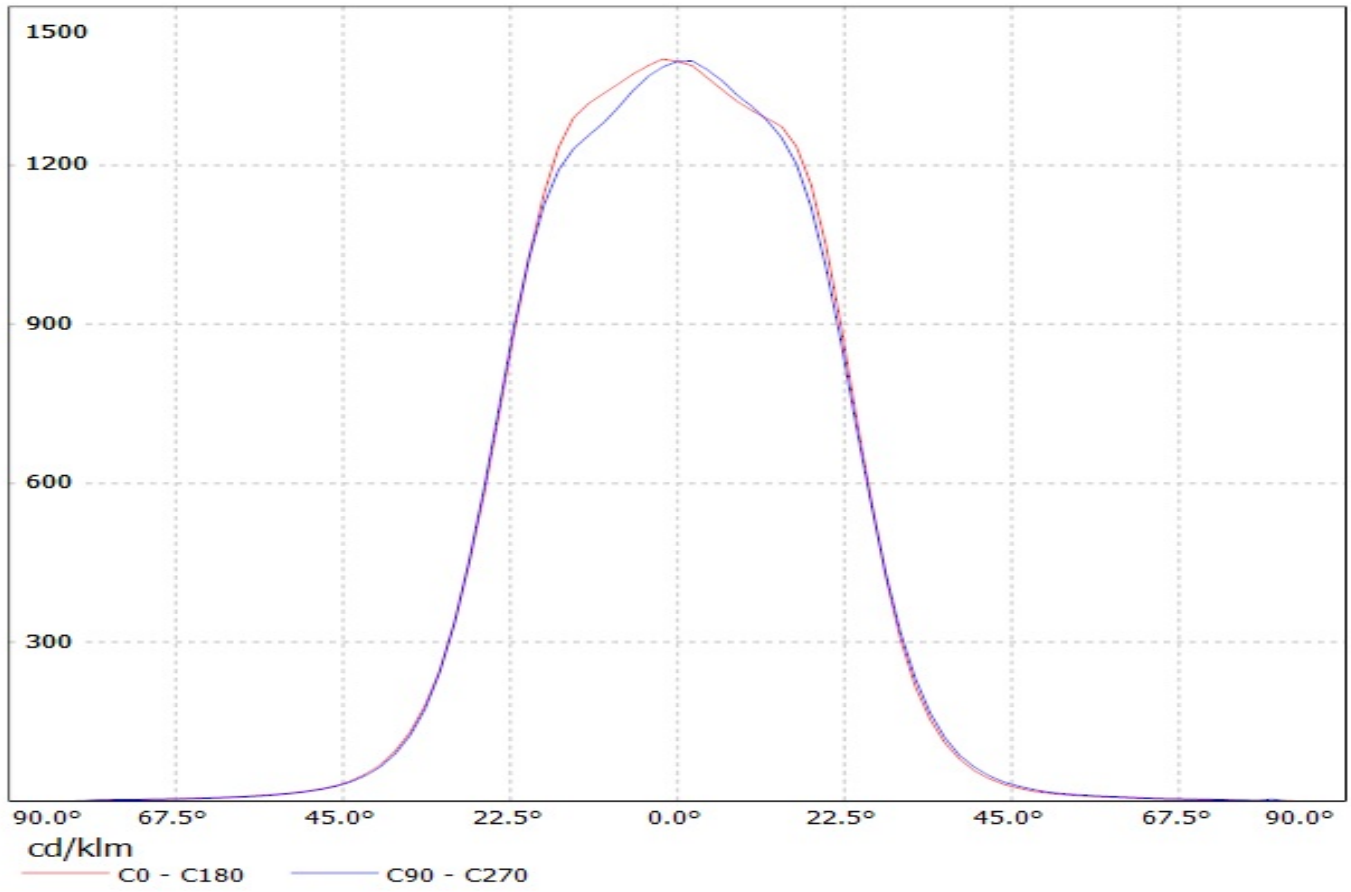

Luminaire: LEDiL Oy C13605_HB-2X2-RW_(WICOP2_Z8Y15)

Lamps: 1 x SEOUL_WICOP2_Z8Y15_336.842lm@250mA_P=2.9399W_I=0.250A

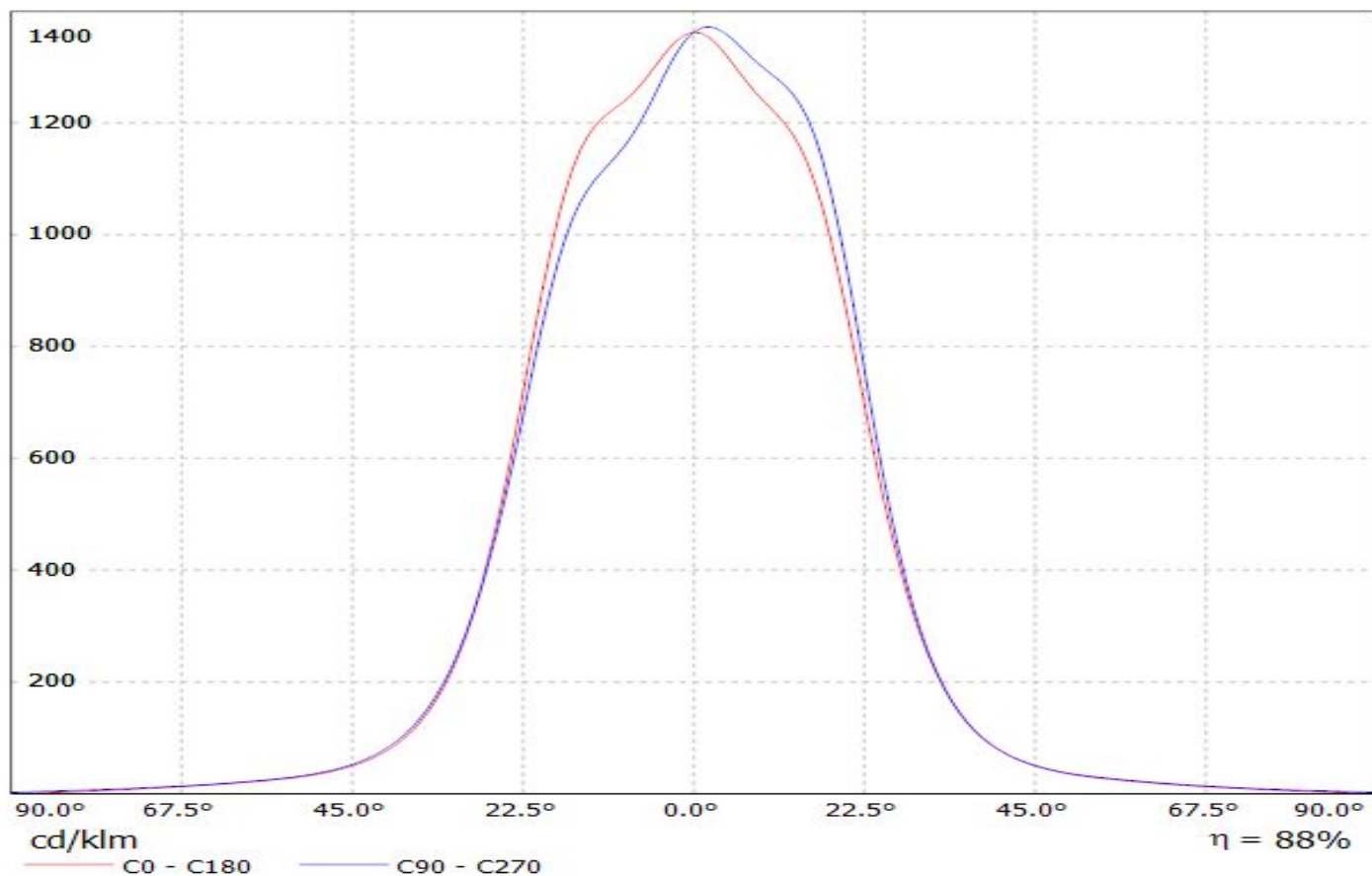

Luminaire: LEDiL Oy C13605_HB-2X2-RW_(WICOP2_Z8Y19)

Lamps: 1 x SEOUL_WICOP2_Z8Y19_450.124lm@250mA_P=2.8579W_I=0.250A

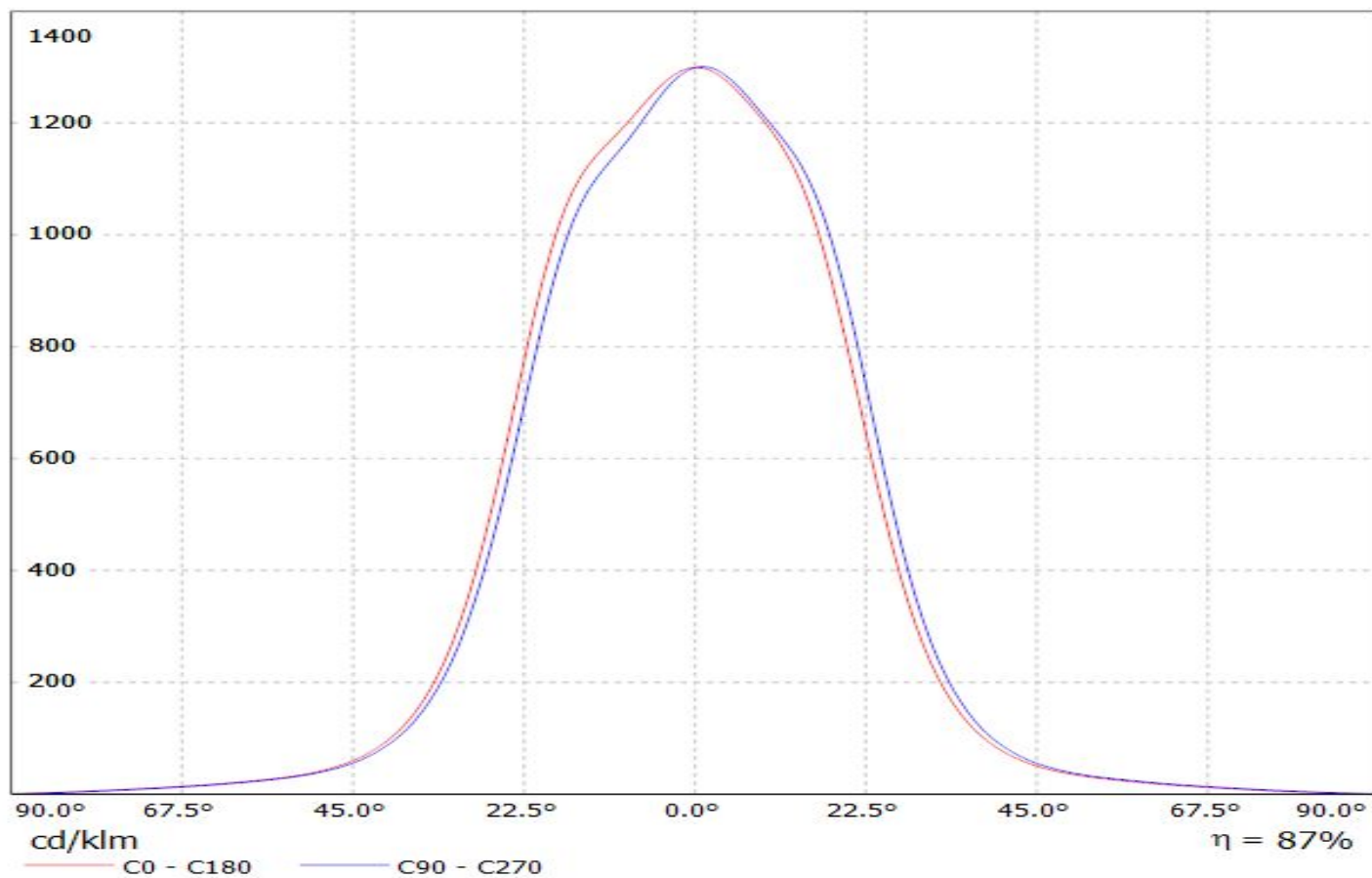

Luminaire: LEDiL Oy C13605_HB-2X2-RW_(Z8Y22)

Lamps: 1 x Seoul_Wicop_Z8Y22_497.373lm@250mA_P=2.80076W_U=11.211V

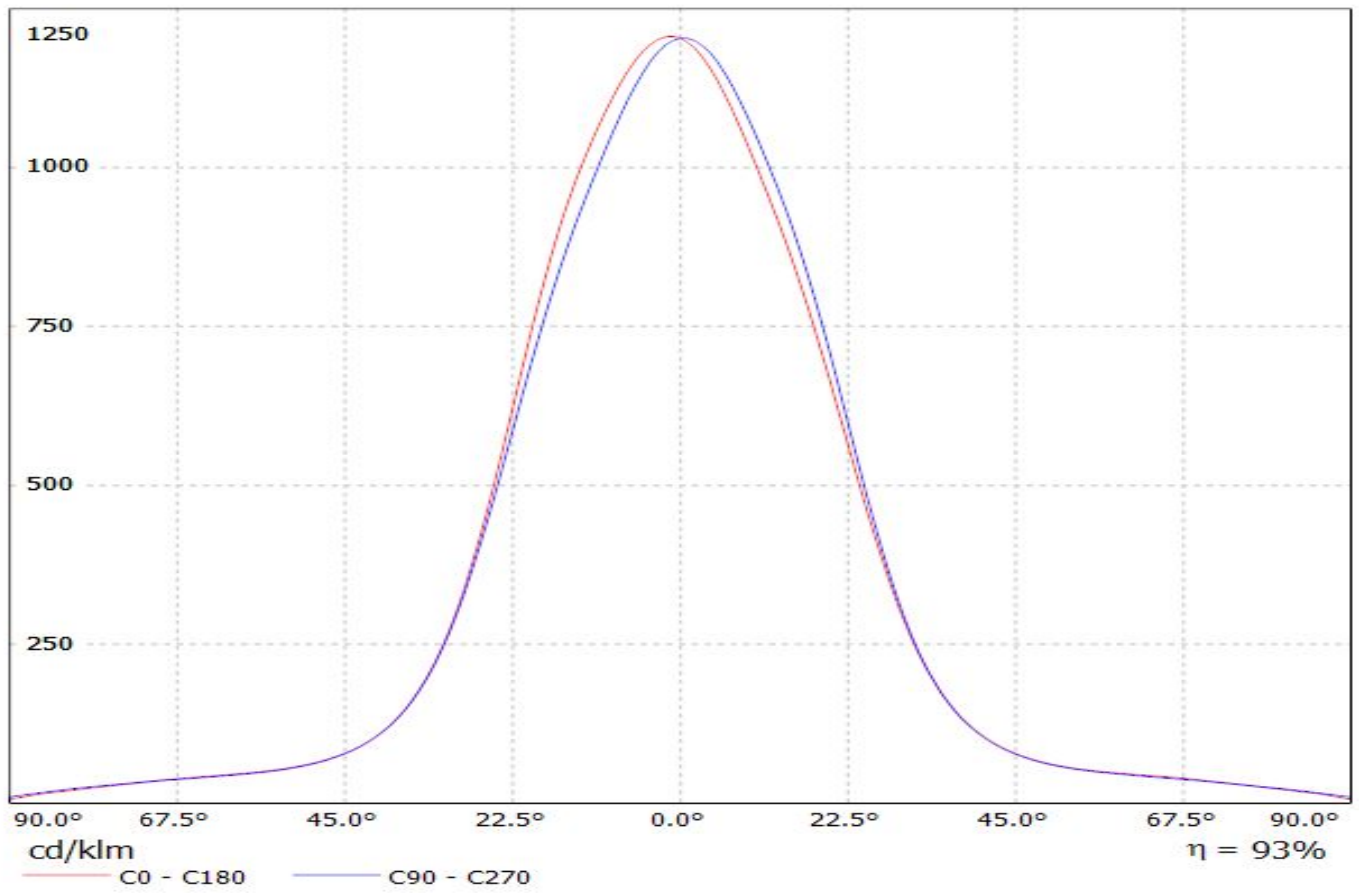

Ledil C13605_HB-2X2-RW_(TL1L4) / LDC (Linear)

Luminaire: Ledil C13605_HB-2X2-RW_(TL1L4)

Lamps: 1 x Toshiba_TL1L4_2x2_(TL1L4-DW0)_472.639lm@250mA_CCT=6500K_P=2.9W_I=0.25A

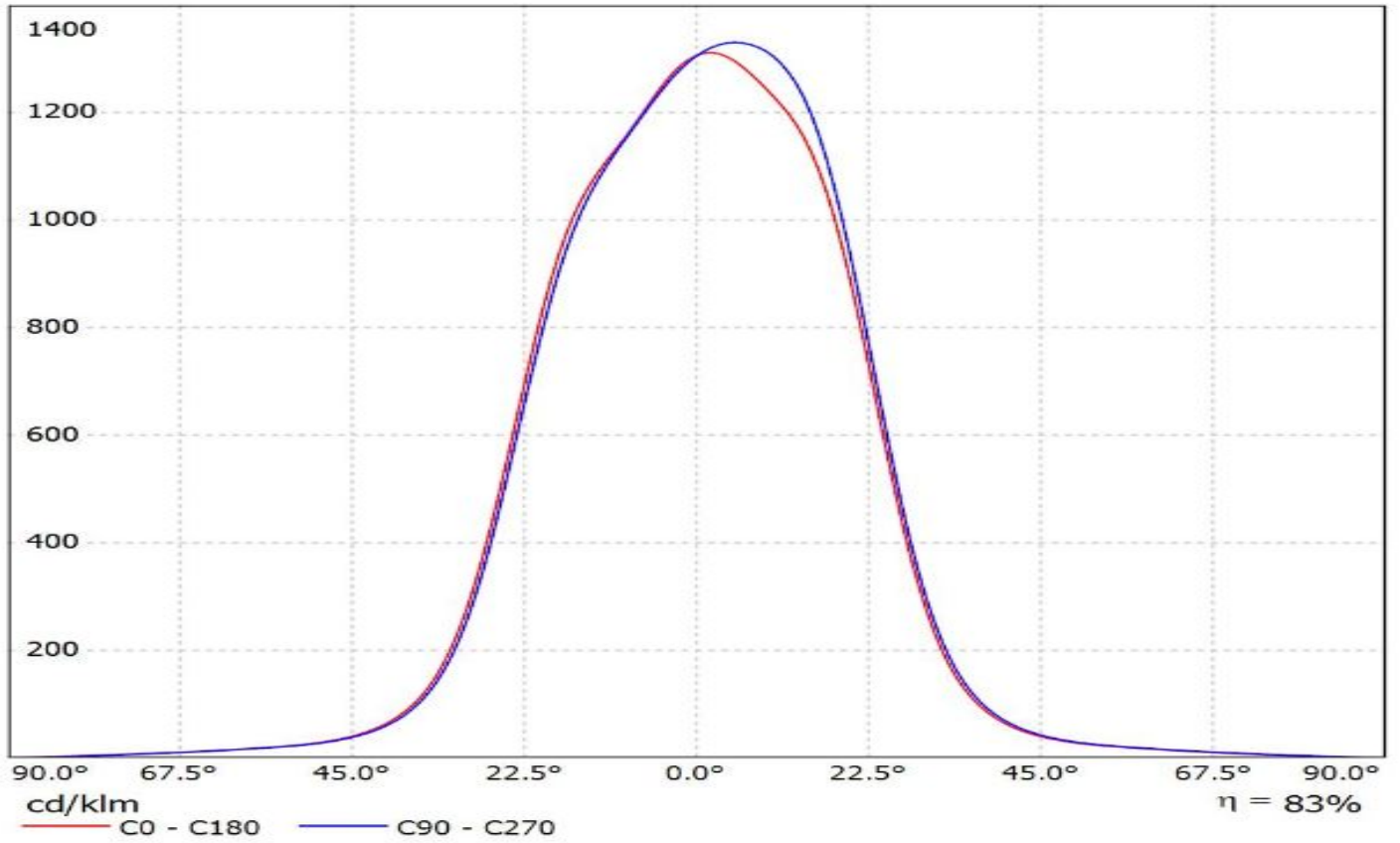

Luminaire: LEDiL Oy C13605_HB-2X2-RW_(Tridonic_Module_RLE_G1)
Lamps: 1 x Tridonic_Module_RLE_G1_4576.03lm@700mA_P=32.0681W_I=0.700A

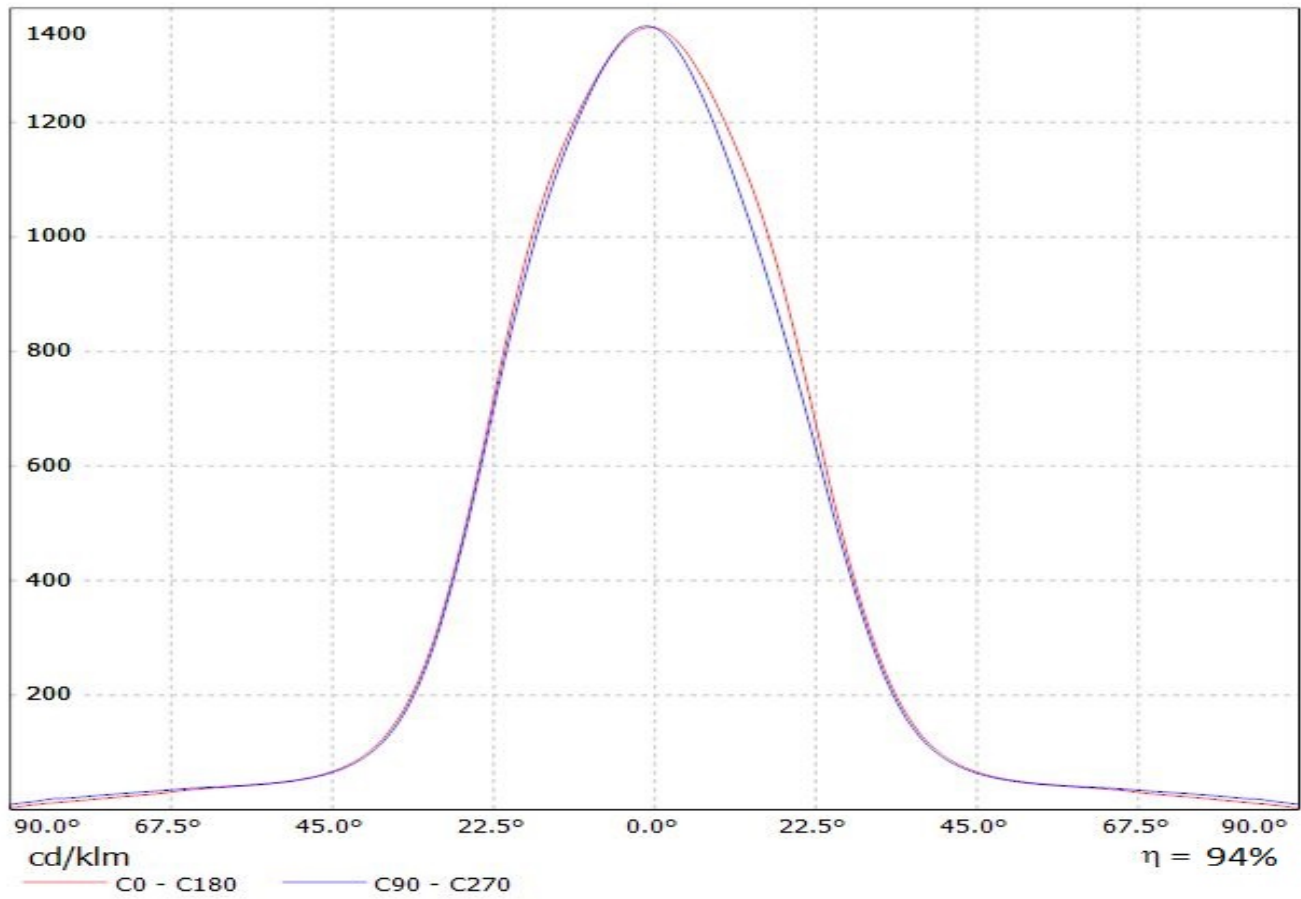

Luminaire: LEDiL Oy C13605_HB-2X2-RW_(Tridonic_Module_RLE_G1)
Lamps: 1 x Tridonic_Module_RLE_G1_4576.03lm@700mA_P=32.0681W_I=0.700A

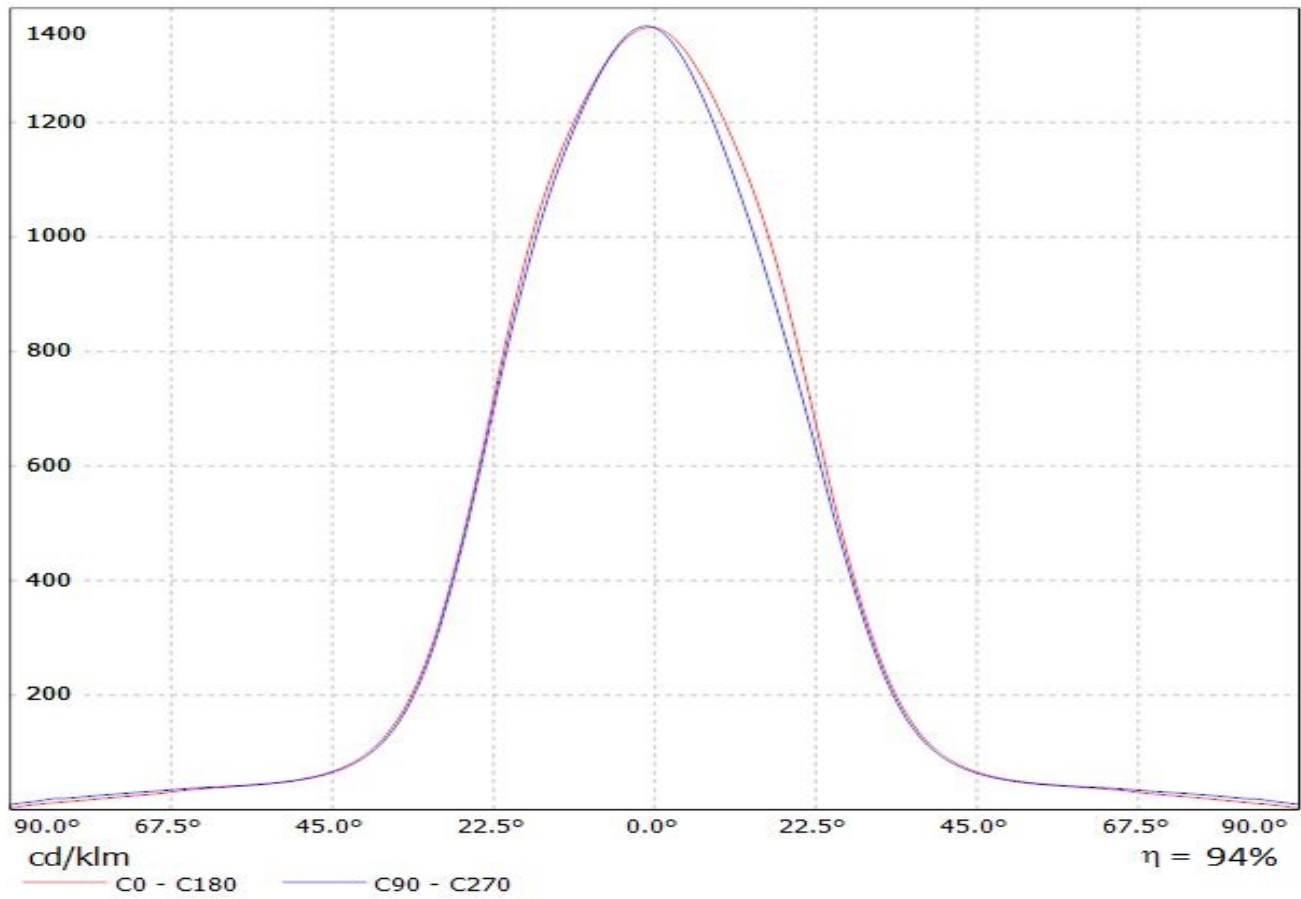

Luminaire: LEDiL Oy C13605_HB-2X2-RW_(Tridonic_Module_RLE_G1)
Lamps: 1 x Tridonic_Module_RLE_G1_2288lm@700mA_P=16W_I=0.700A

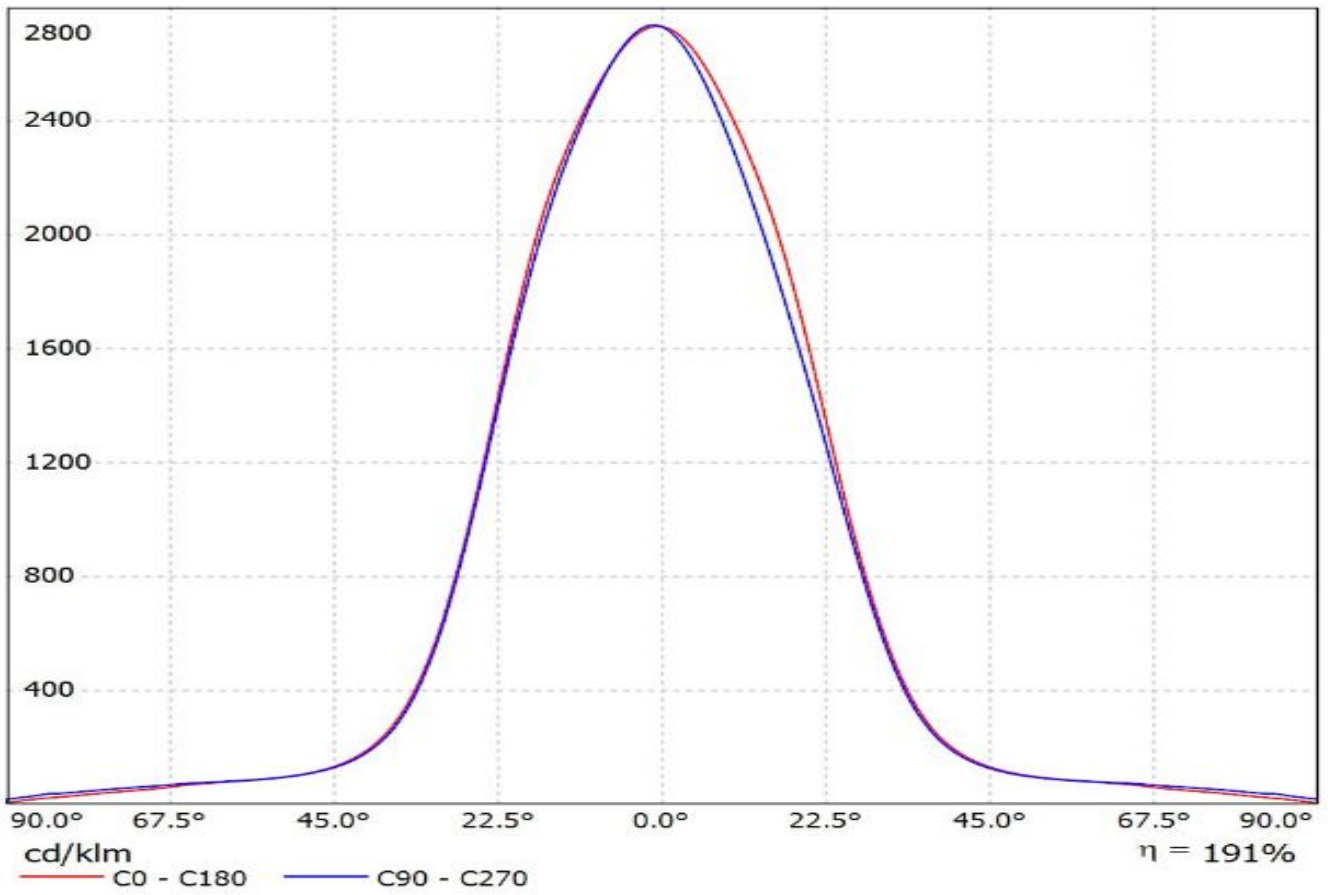

Luminaire: LEDiL Oy C13605_HB-2X2-RW_(Tridonic_Module_RLE_G1)
Lamps: 1 x Tridonic_Module_RLE_G1_2288lm@700mA_P=16W_I=0.700A

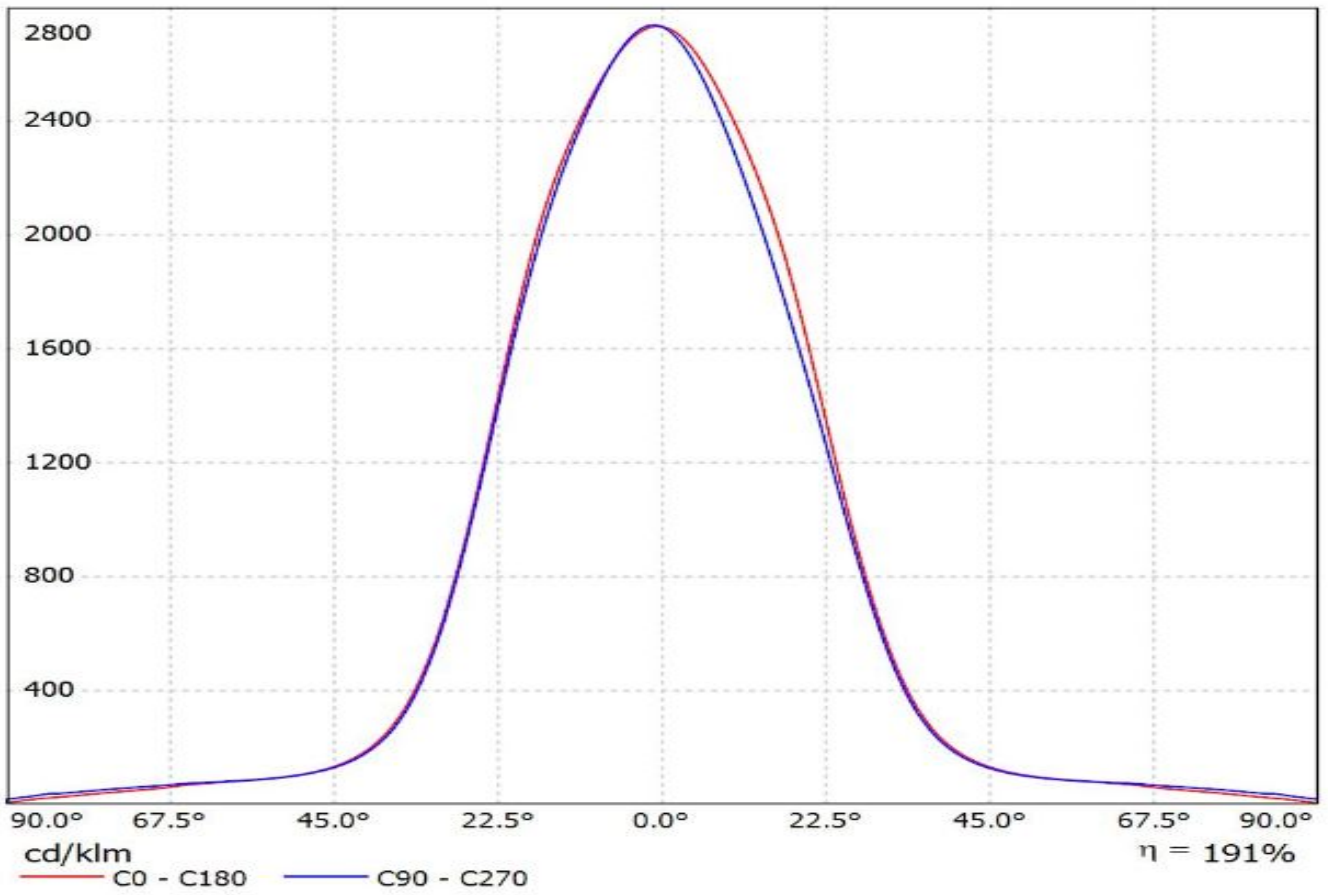

Luminaire: Ledil Oy C13605_HB-2X2-RW (Cree XT-E 390lm @ 250mA) Efficiency=89%
Lamps: 1 x Cree XT-E 390lm @ 250mA CCT=5717K P=3W I=250mA

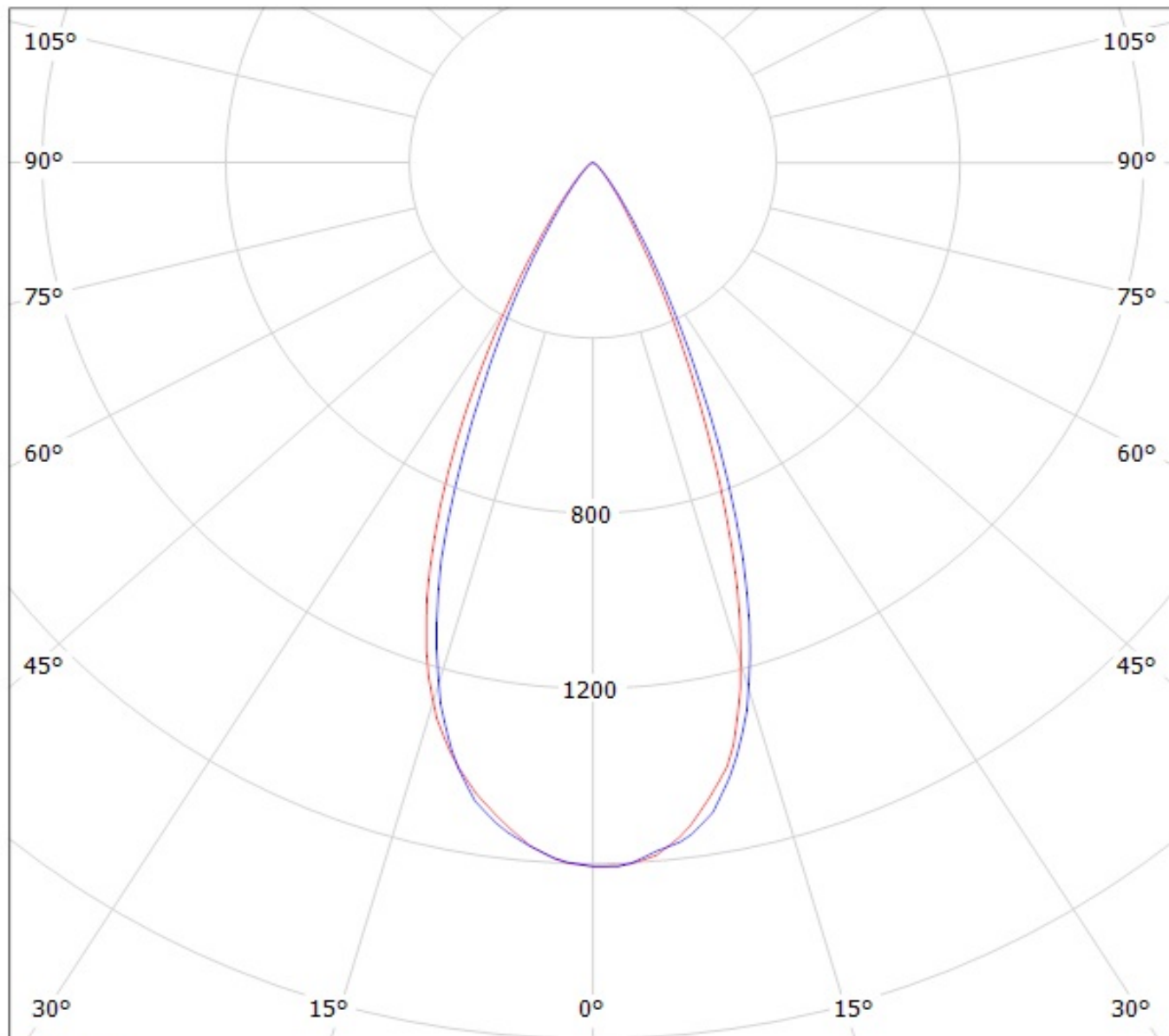

cd/klm

— C0 - C180

— C90 - C270

Luminaire: Ledil Oy C13605_HB-2X2-RW (Cree XP-G2 408lm Im @ 250mA) Efficiency=91%
Lamps: 1 x Cree XP-G2 408lm Im @ 250mA CCT=7181K P=3W I=250mA

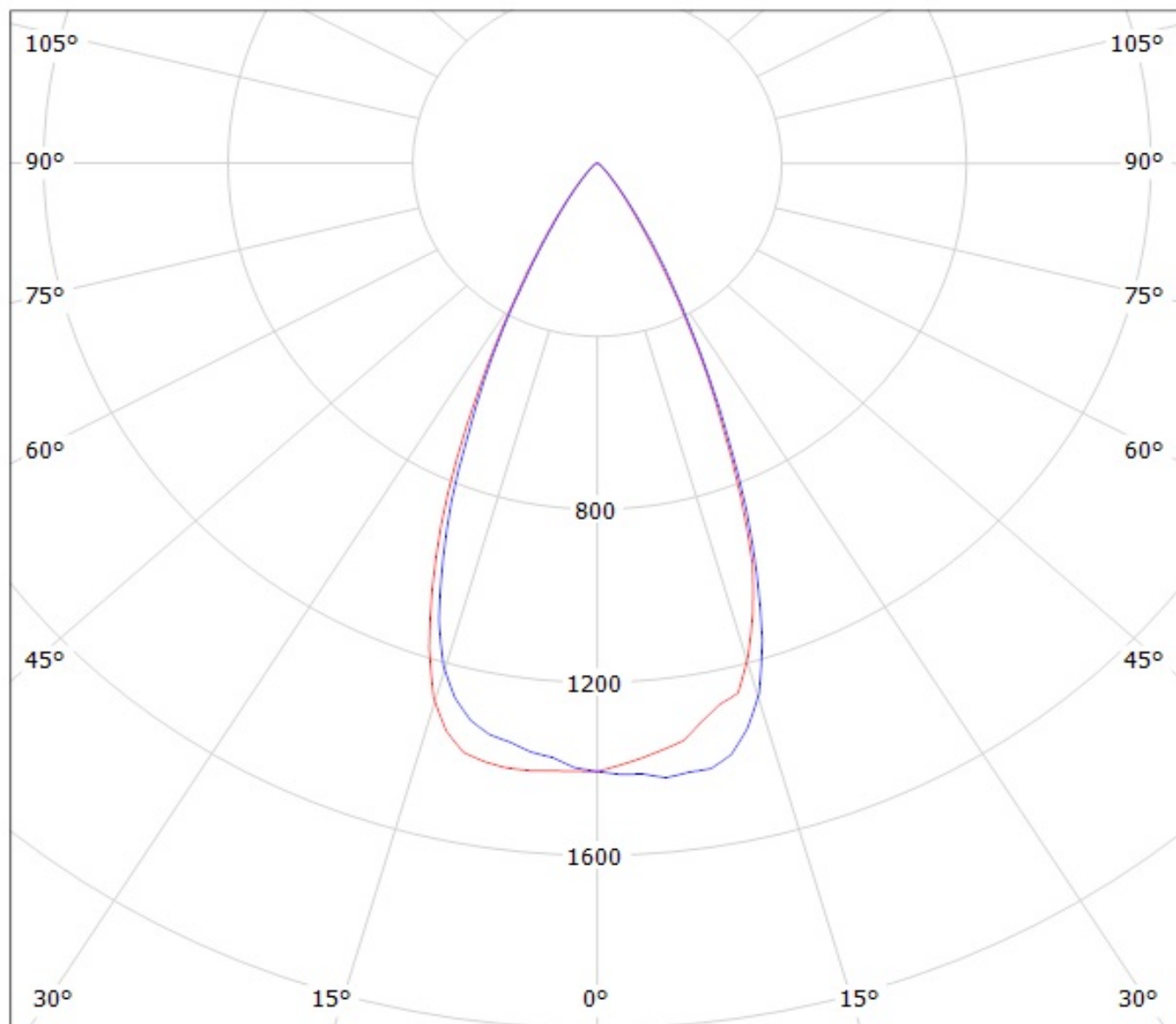

cd/klm

— C0 - C180

— C90 - C270

Luminaire: Ledil Oy C13605_HB-2X2-RW_(XP-G) Efficiency=89%
Lamps: 1 x Cree XP-G (254lm @ 250mA) CCT=3300K P=2.9W I=250mA

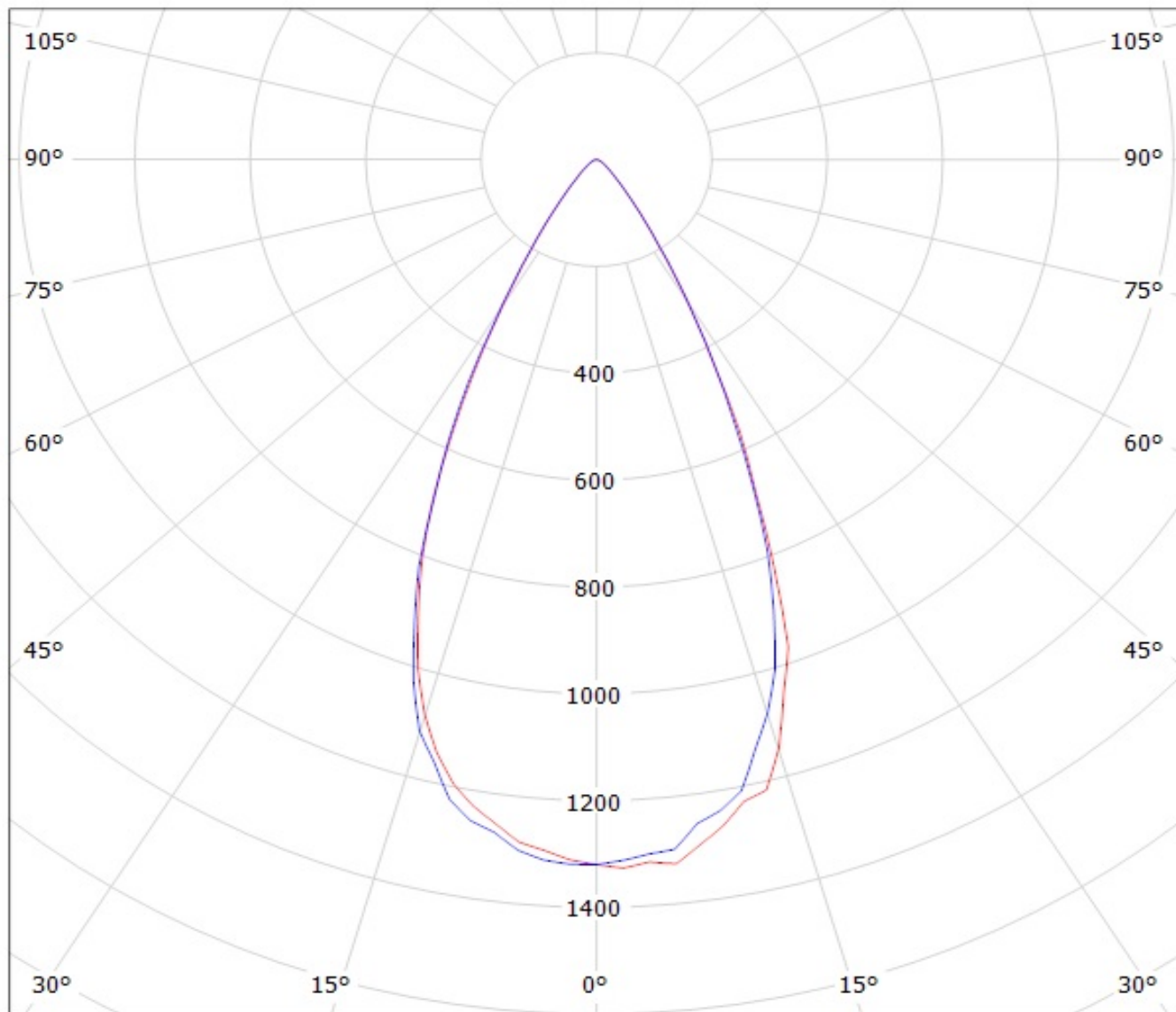

cd/klm

— C0 - C180

— C90 - C270

Luminaire: Ledil Oy C13605_HB-2x2-RW_(XP-E) Efficiency=89%
Lamps: 1 x Cree XP-E (XPEWHT-L1-3C0-W5-0-06) 302lm @ 250mA CCT=5400K P=3.1W I=250mA

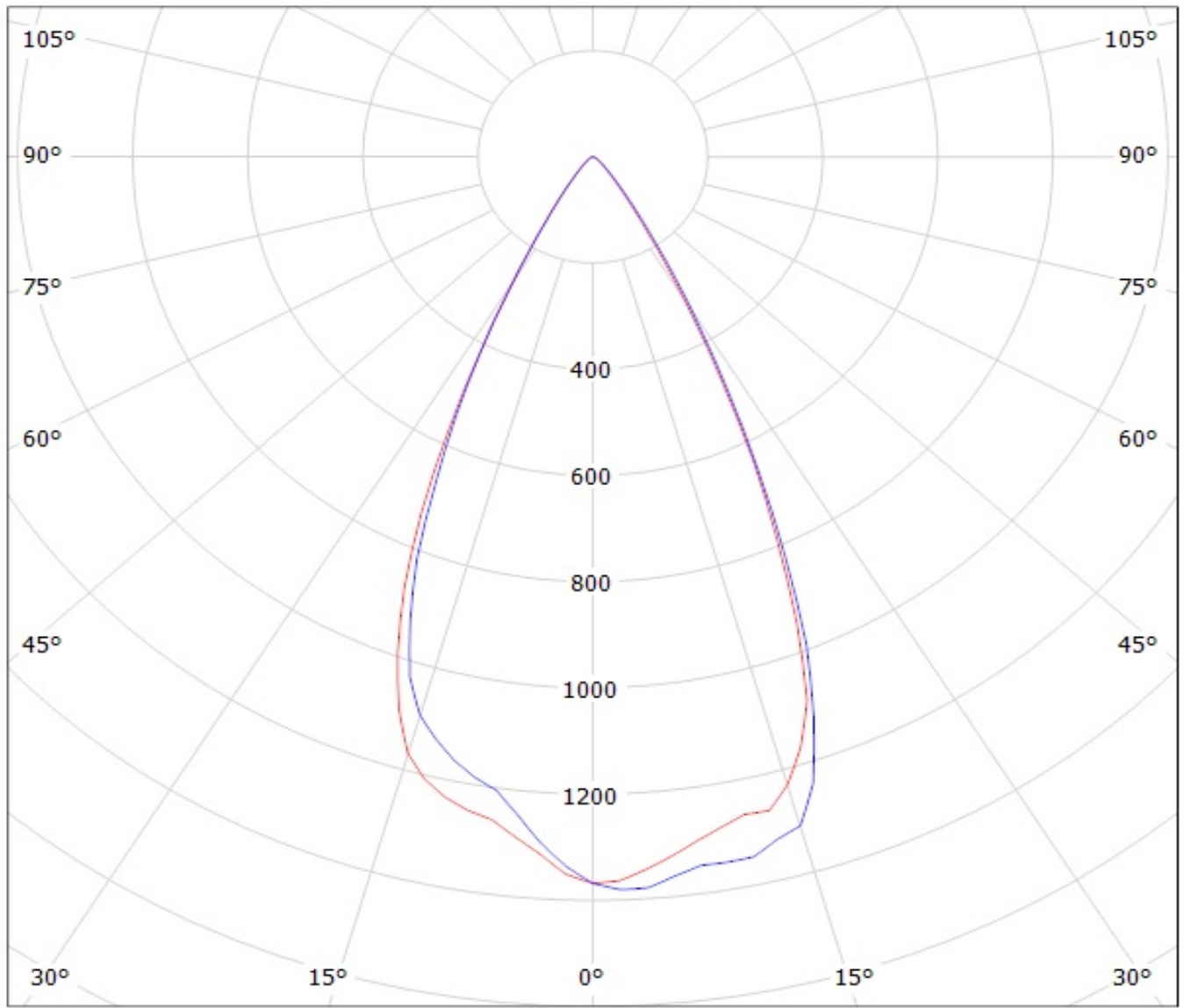

cd/klm

— C0 - C180 — C90 - C270

Luminaire: Ledil Oy C13605_HB-2X2-RW_(XB-D) Efficiency=88%
Lamps: 1 x Cree XB-D (365lm @ 250mA) CCT=6800K P=3.1W I=250mA

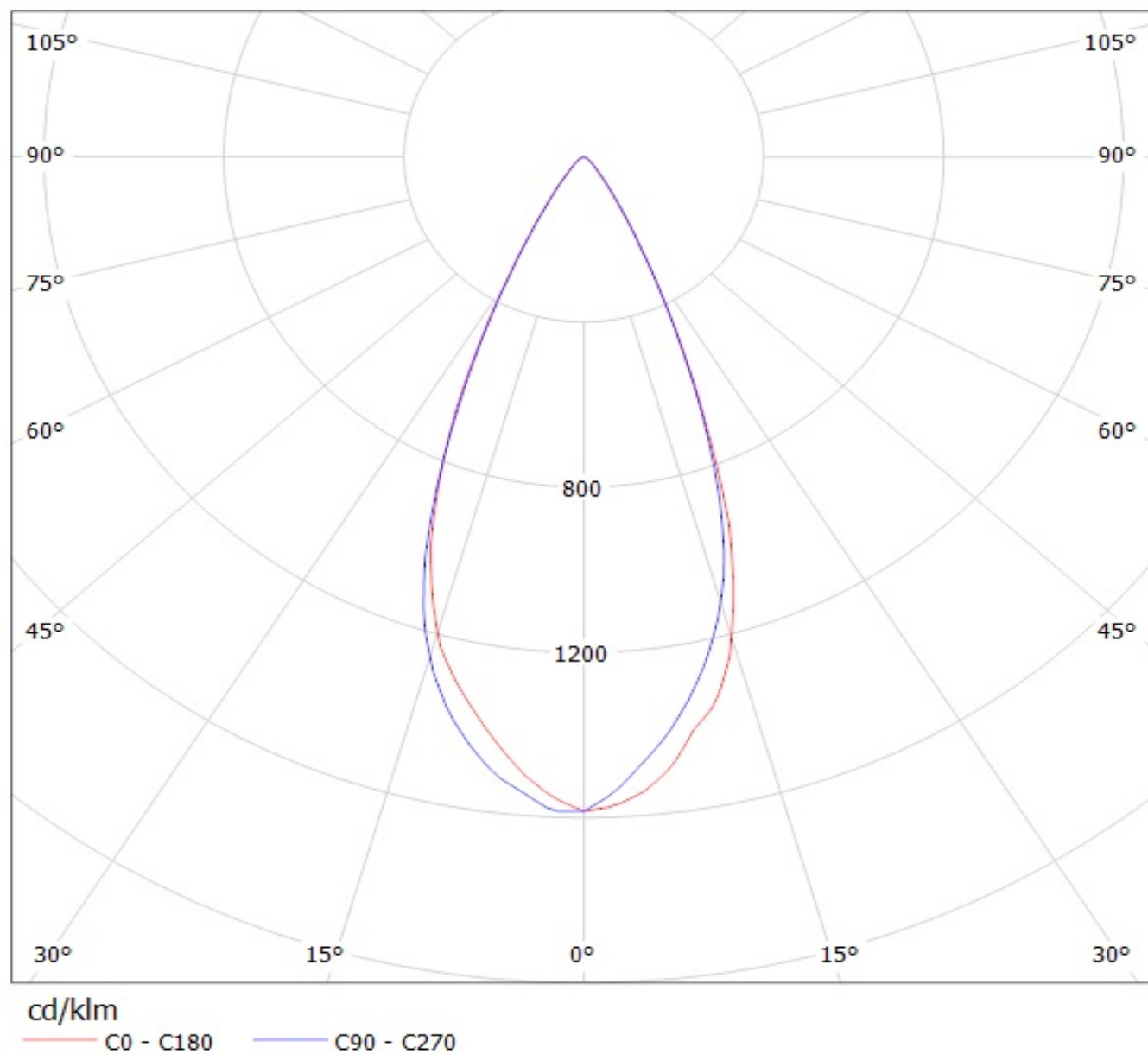

Luminaire: Ledil Oy C13605_HB-2X2-RW_(NCSxx19A) Efficiency=90%
Lamps: 1 x Nichia NCSxx19A (NCSL119AT-H1) (229lm @ 250mA) CCT=2800K P=3.1W I=250mA

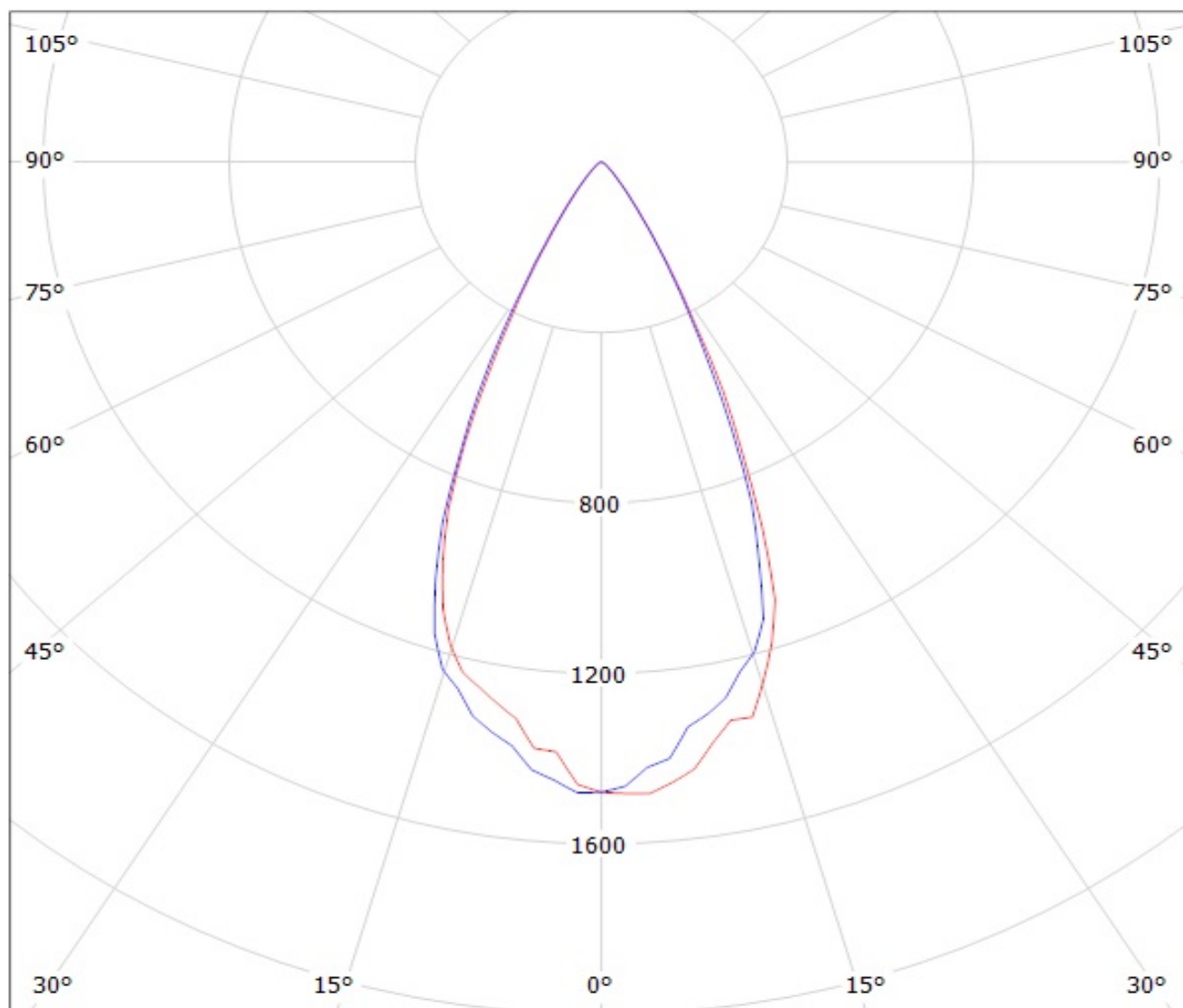

cd/klm

— C0 - C180

— C90 - C270

Luminaire: Ledil Oy C13605_HB-2x2-RW_(NVSxx19A) Efficiency=88%
Lamps: 1 x Nichia NVSxx19A (NVS219AT) 382lm @ 250mA CCT=5290K P=2.9W I=250mA

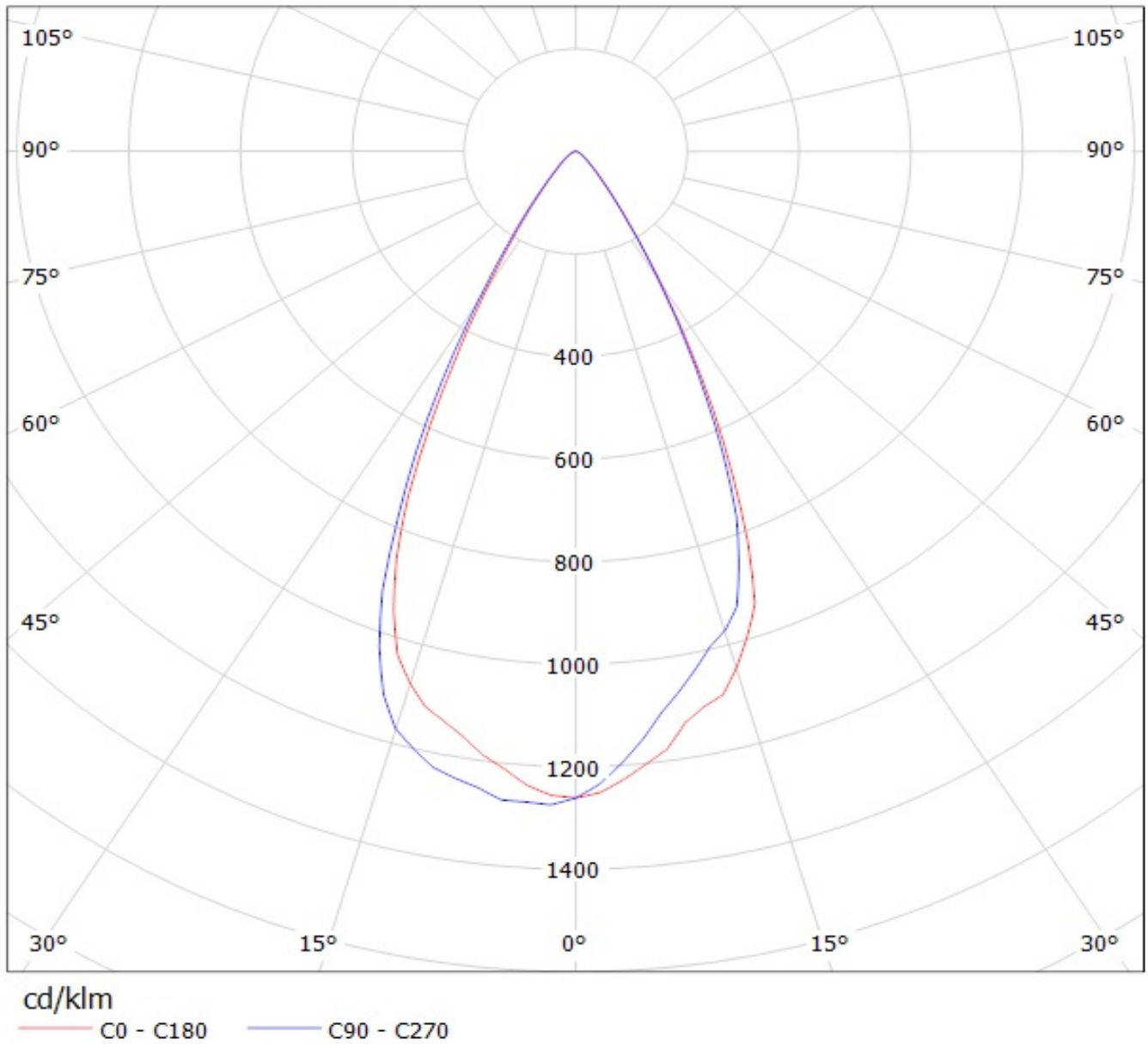

Luminaire: Ledil Oy C13605_HB-2X2-RW_(NVSxx19B) Efficiency=90%
Lamps: 1 x Nichia NVSxx19B (NVSL219BE) 308lm @ 250mA CCT=3100K P=2.9W I=250mA

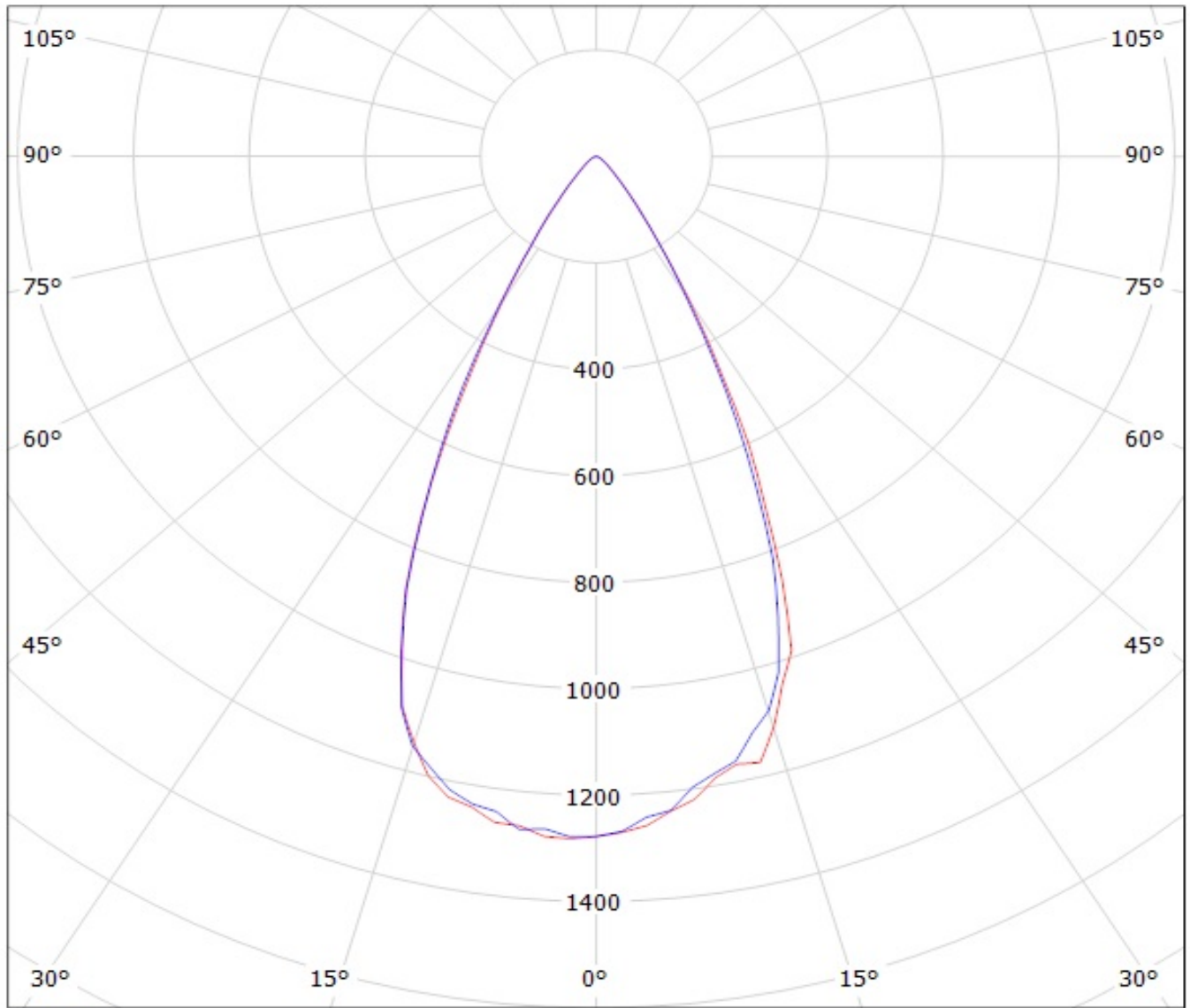

cd/klm

— C0 - C180

— C90 - C270

Luminaire: LEDiL Oy C13605_HB-2X2-RW_(E21A)

Lamps: 1 x Nichia_E21A_2X2_454.11lm@250mA_P=2.81W_I=0.250A

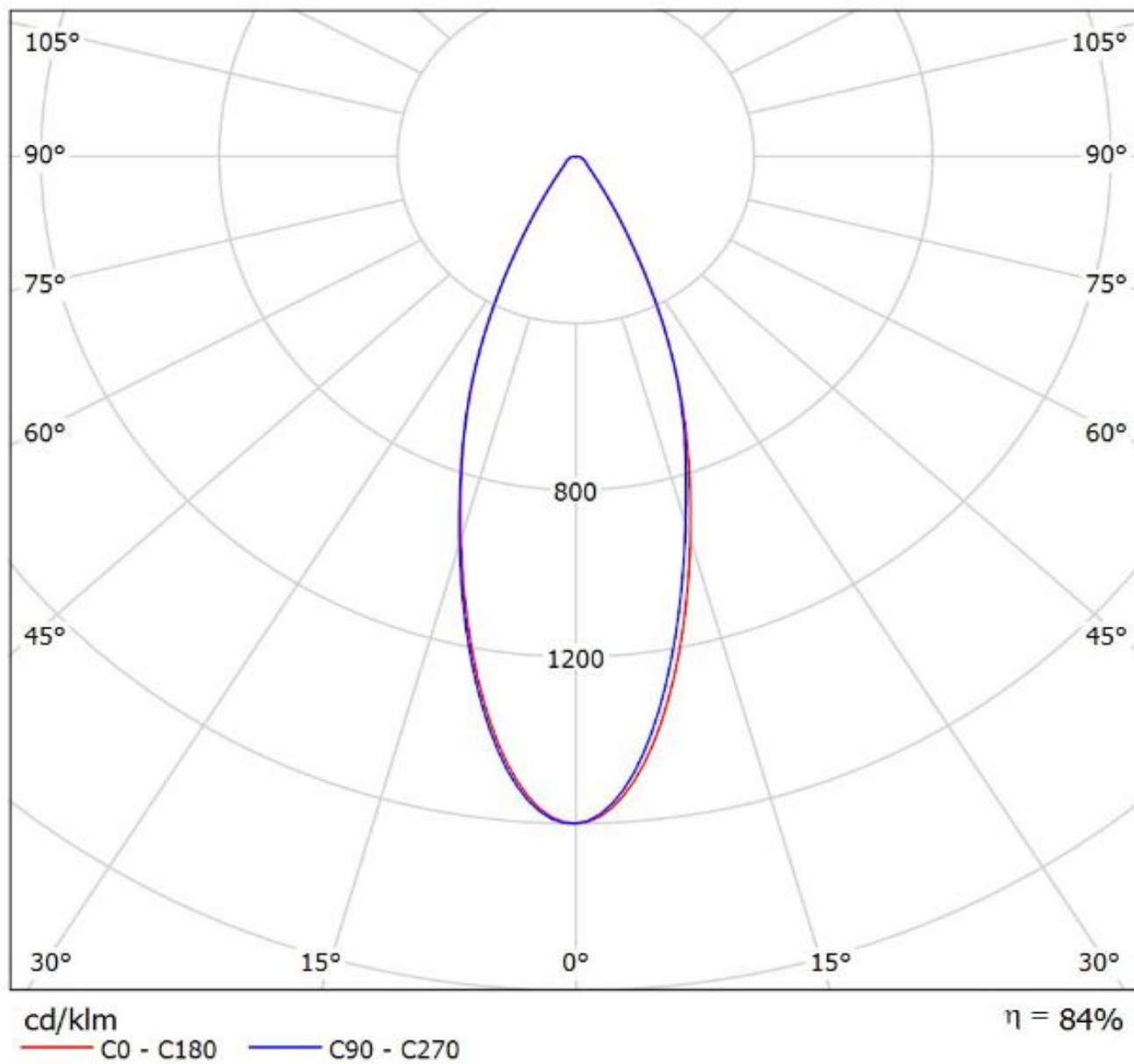

Luminaire: Ledil Oy C13605_HB-2X2-RW_(Oslon_Square_PC) Efficiency=90%

Lamps: 1 x Osram Oslon Square PC (LCW-CQAR.PC-MSMU-5H71-1) 389lm @ 250mA CCT=6000K P=3.0W I=250mA

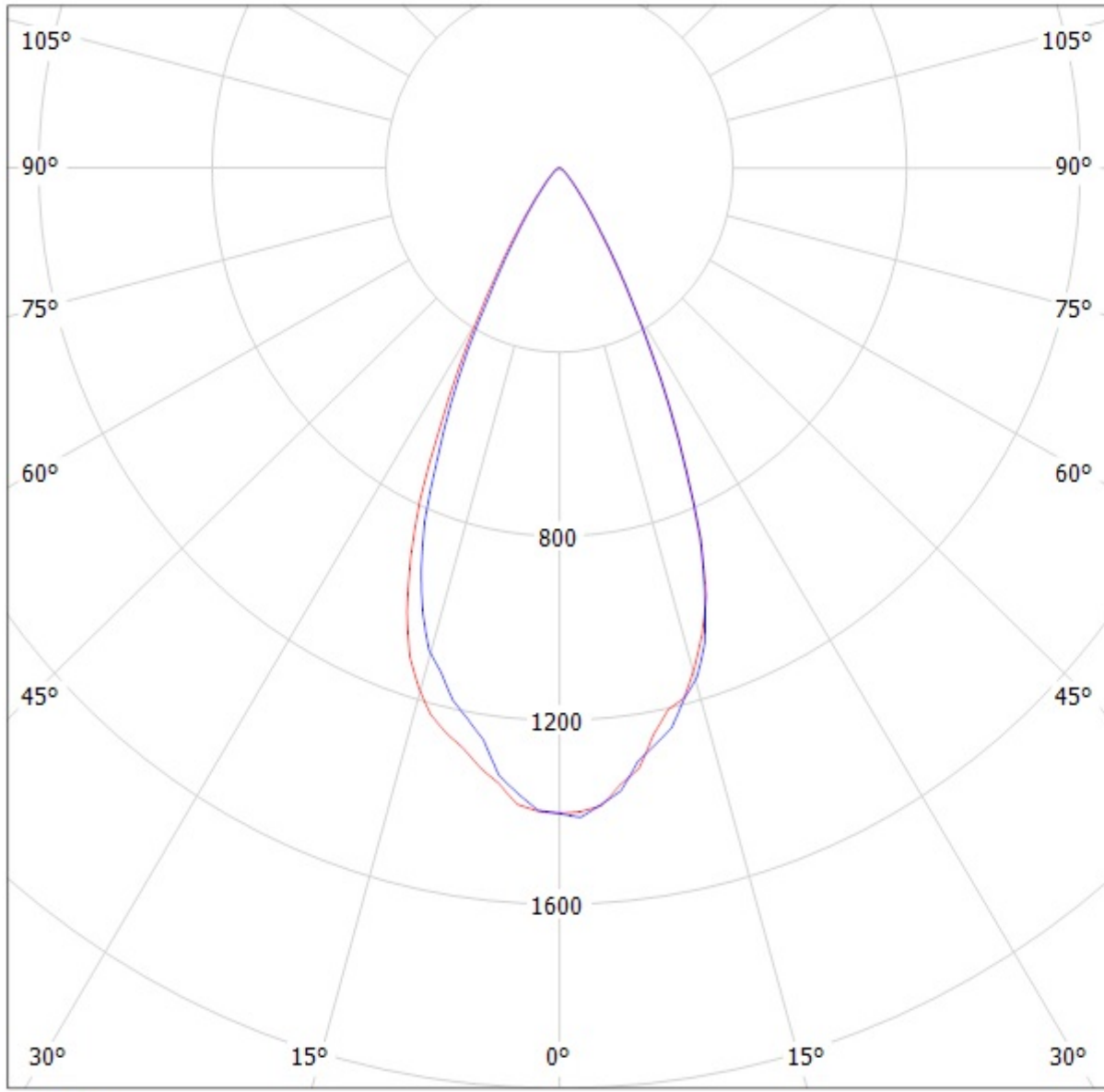

cd/klm

— C0 - C180 — C90 - C270

Luminaire: Ledil Oy C13605_HB-2X2-RW_(SSL_80) Efficiency=90%
Lamps: 1 x Osram Oslon SSL 80 (310lm @ 250mA) CCT=6800K P=3.2W I=250mA

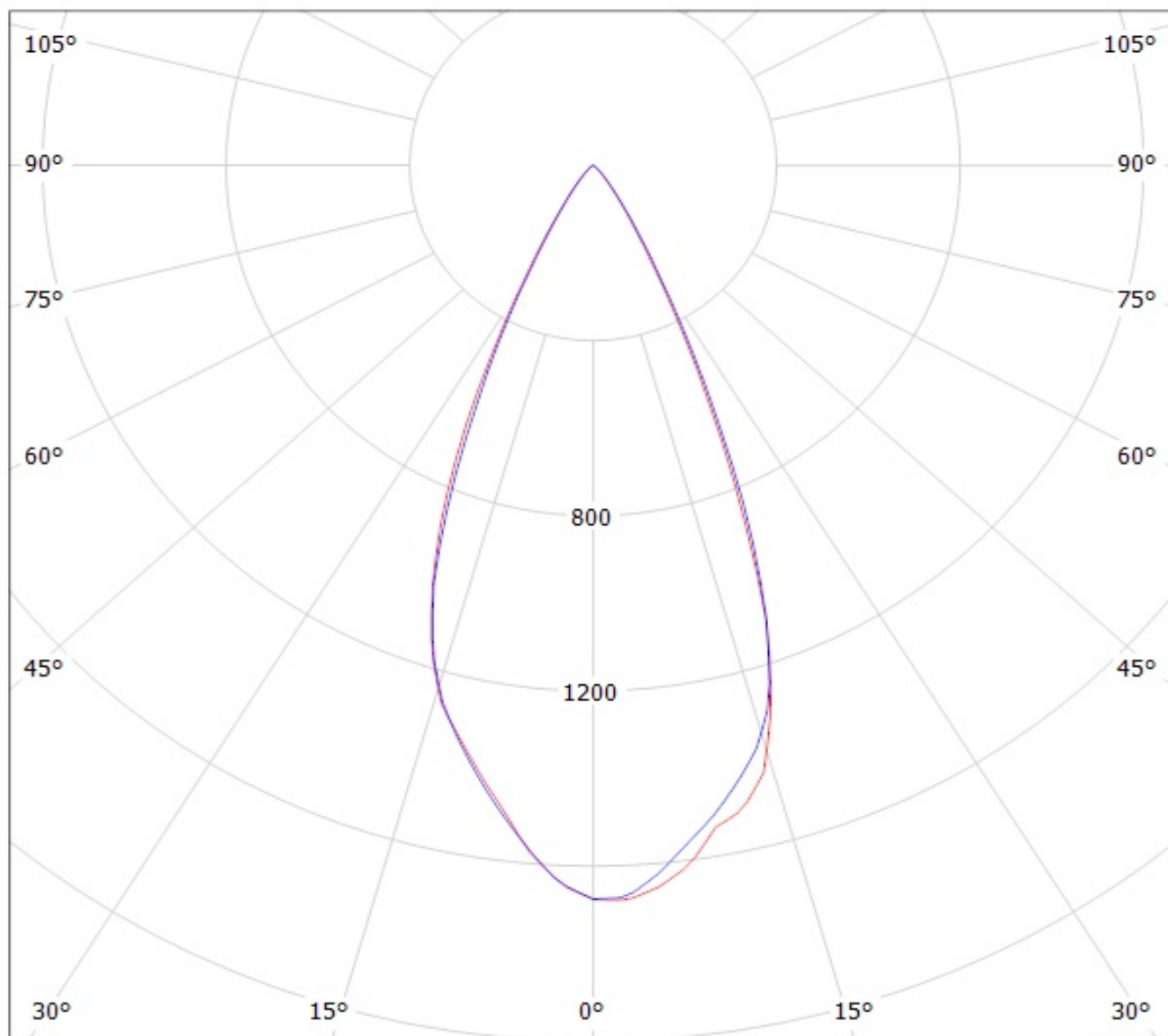

cd/klm

— C0 - C180

— C90 - C270

Luminaire: LEDiL Oy
Lamps: 1 x C13605-HB-2x2-RW_(SQ_Gen3)

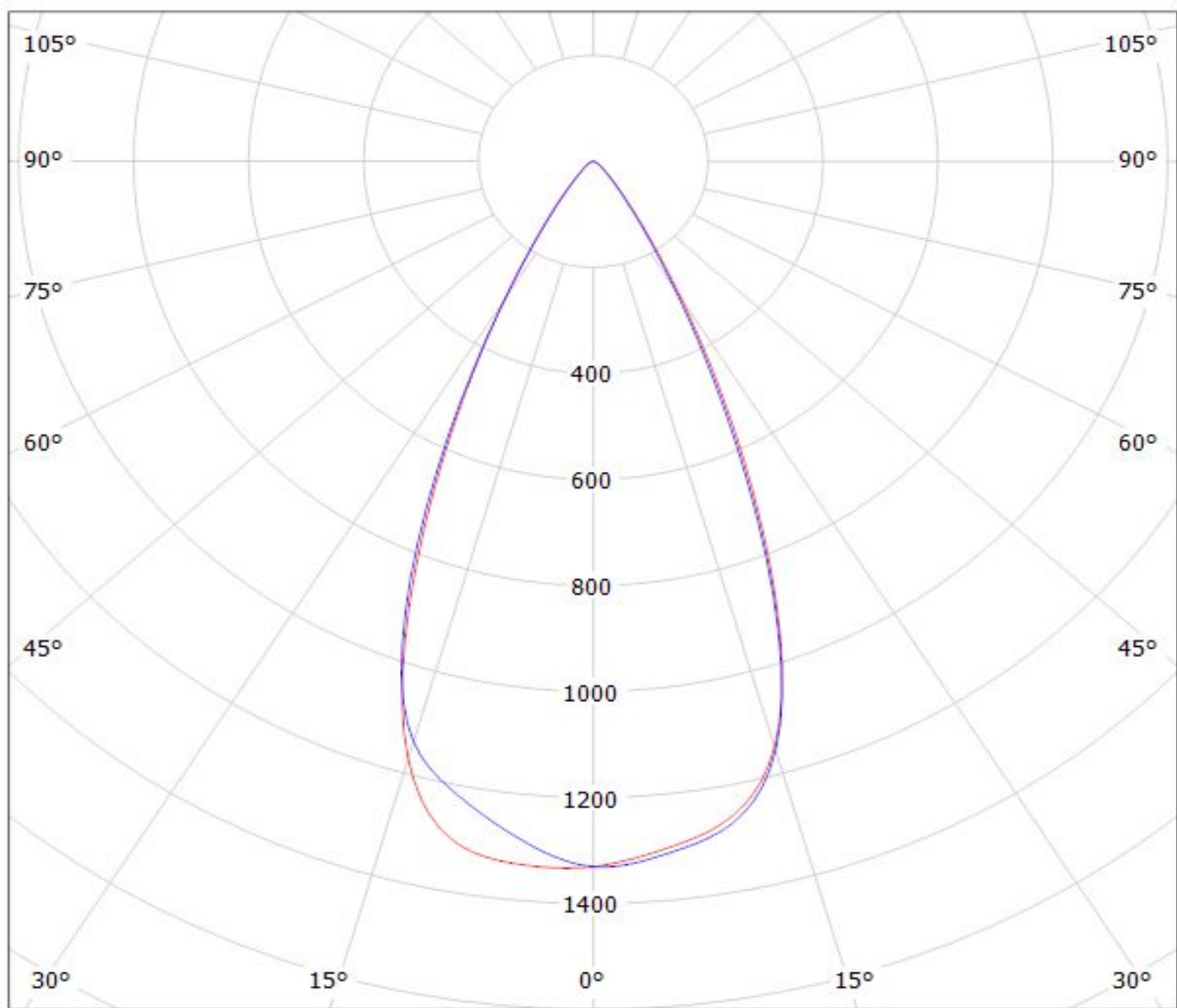

cd/klm

— C0 - C180 — C90 - C270

$\eta = 89\%$

Luminaire: LEDiL Oy C13605_HB-2X2-RW_(LH351Z) Eff.90.2%

Lamps: 1 x SAMSUNG_LH351Z_2x2_359.49lm@250mA_P=2.86371W_I=249.8mA

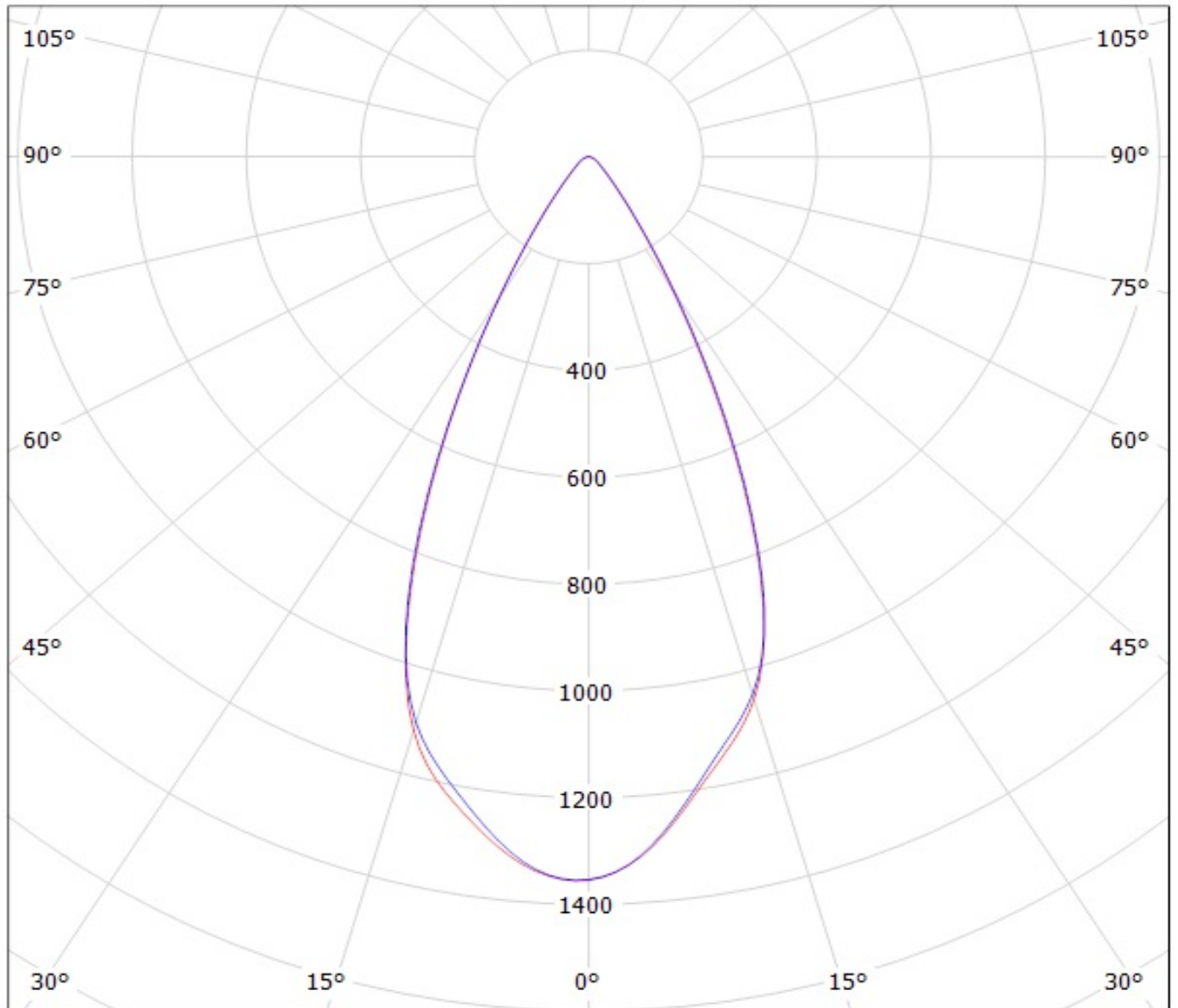

cd/klm

— C0 - C180

— C90 - C270

Luminaire: LEDil Oy C13605_HB-2x2-RW_(Z5M1) Efficiency=90%
Lamps: 1 x Seoul (SZ5-M1-WN-C8) 379lm @ 250mA CCT=4600K P=2.9W I=250mA

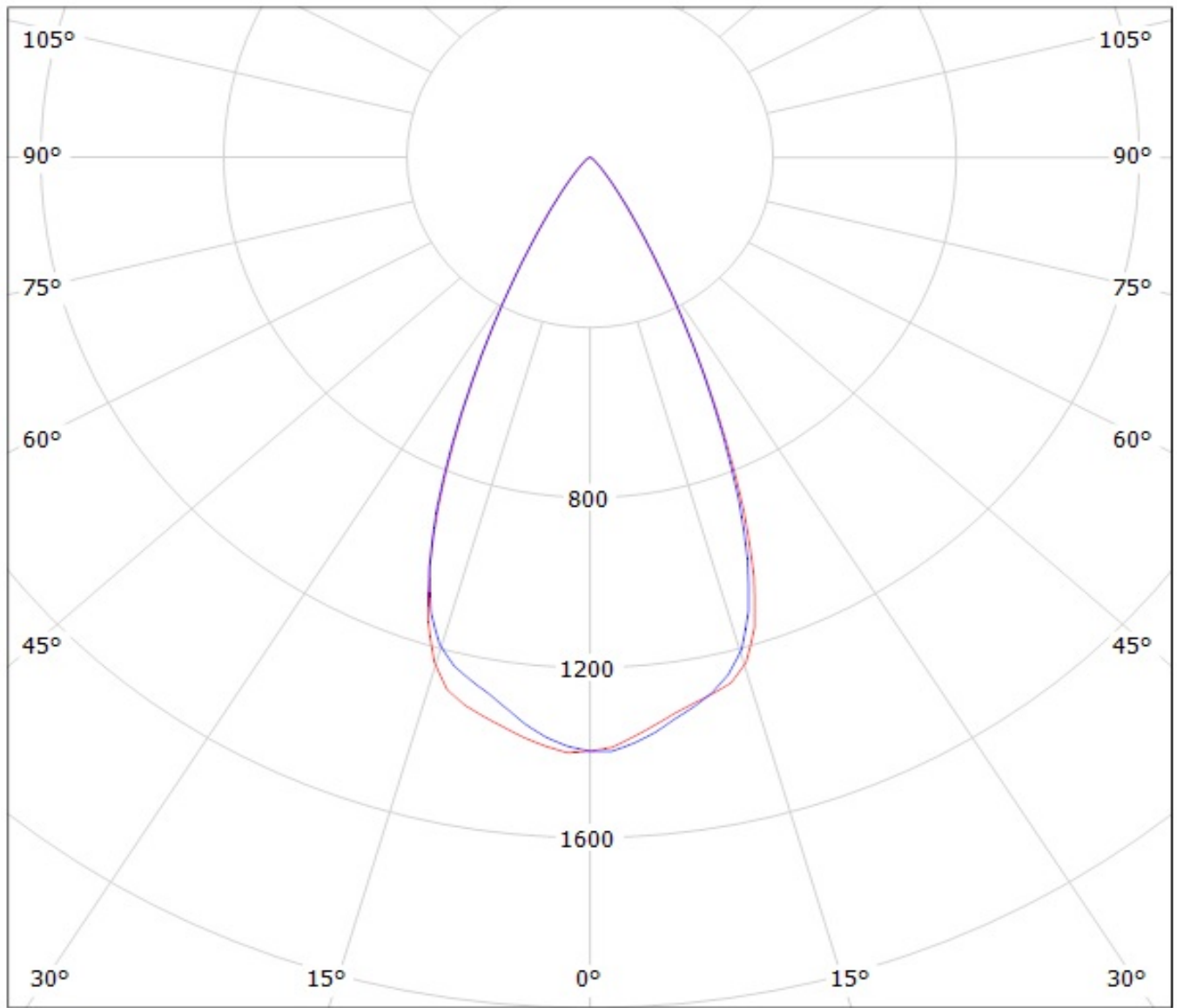

cd/klm

— C0 - C180

— C90 - C270

Luminaire: LEDiL Oy C13605_HB-2X2-RW_(WICOP2_Z8Y15)

Lamps: 1 x SEOUL_WICOP2_Z8Y15_336.842lm@250mA_P=2.9399W_I=0.250A

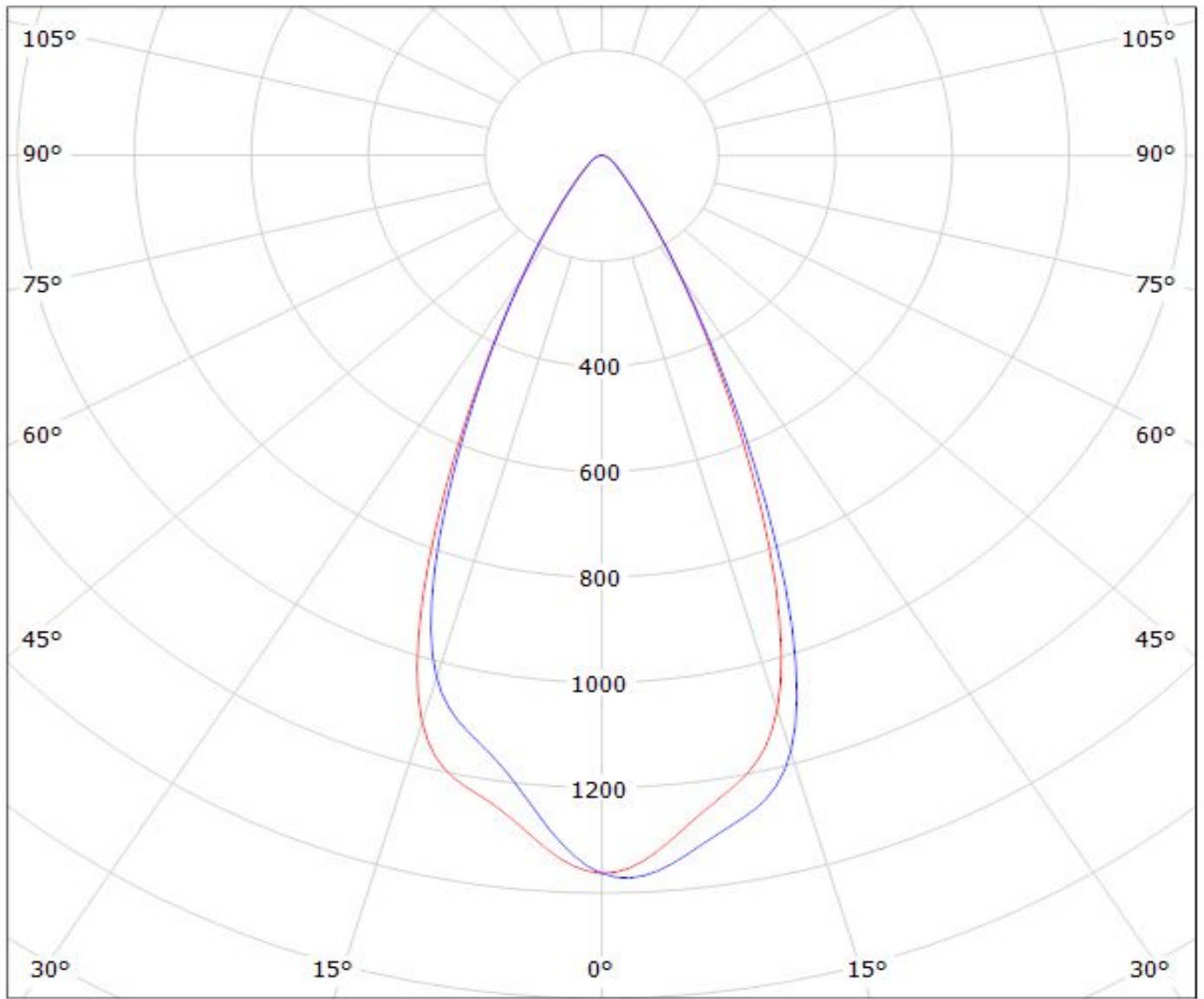

cd/klm

— C0 - C180 — C90 - C270

$\eta = 88\%$

Luminaire: LEDiL Oy C13605_HB-2X2-RW_(WICOP2_Z8Y19)

Lamps: 1 x SEOUL_WICOP2_Z8Y19_450.124lm@250mA_P=2.8579W_I=0.250A

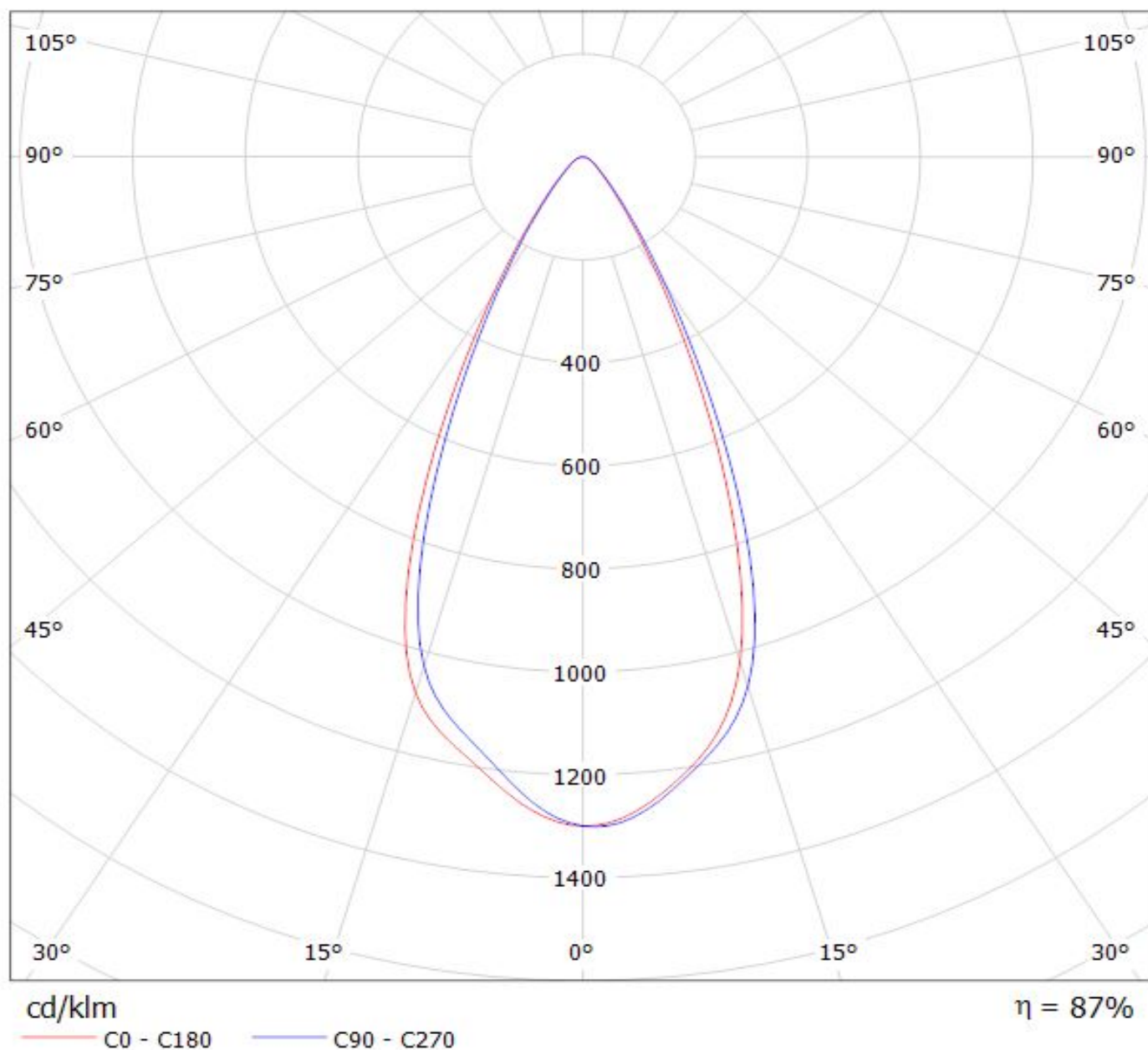

Luminaire: LEDiL Oy C13605_HB-2X2-RW_(Z8Y22)

Lamps: 1 x Seoul_Wicop_Z8Y22_497.373lm@250mA_P=2.80076W_U=11.211V

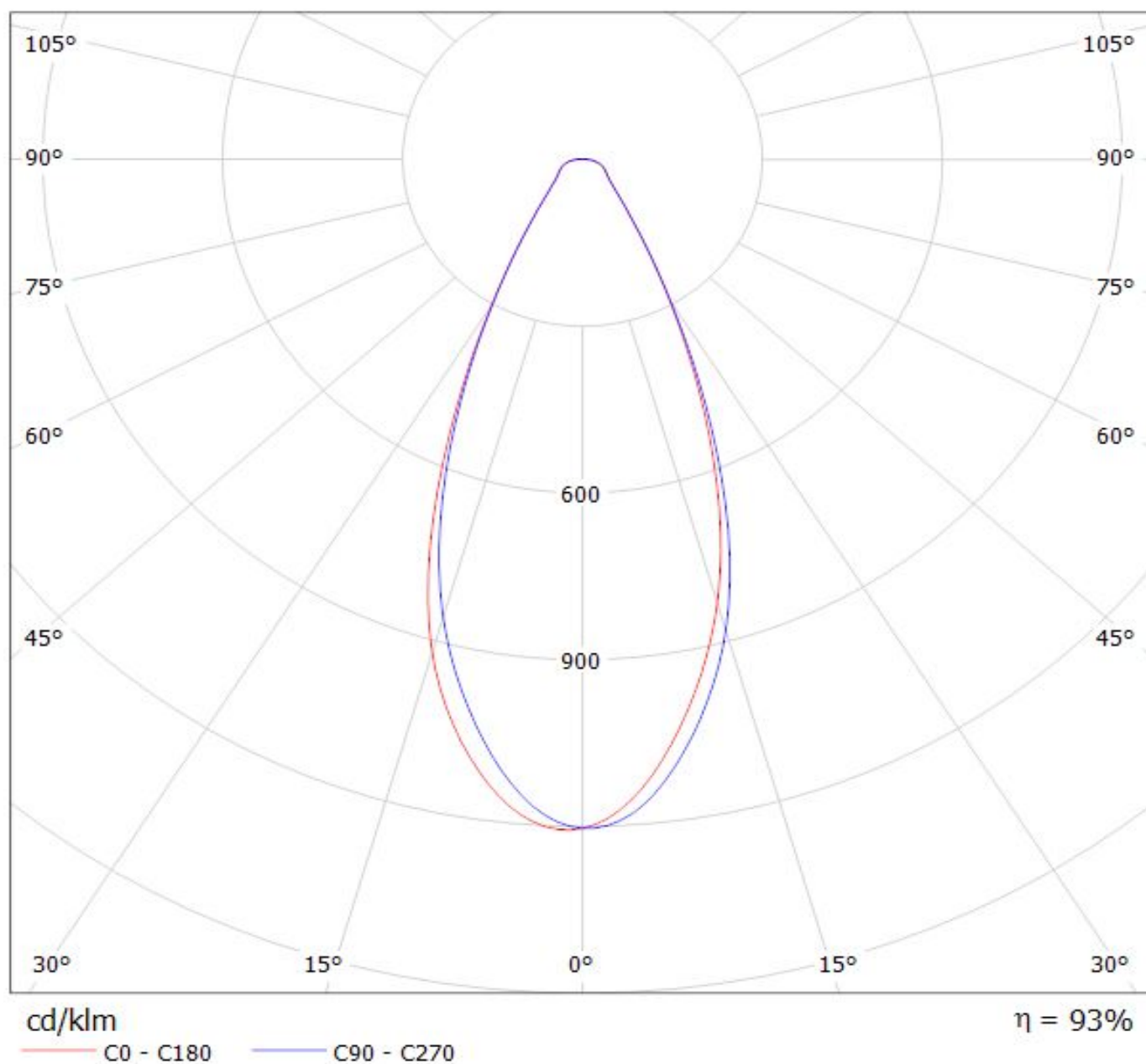

Ledil C13605_HB-2X2-RW_(TL1L4) / LDC (Polar)

Luminaire: Ledil C13605_HB-2X2-RW_(TL1L4)

Lamps: 1 x Toshiba_TL1L4_2x2_(TL1L4-DW0)_472.639lm@250mA_CCT=6500K_P=2.9W_I=0.25A

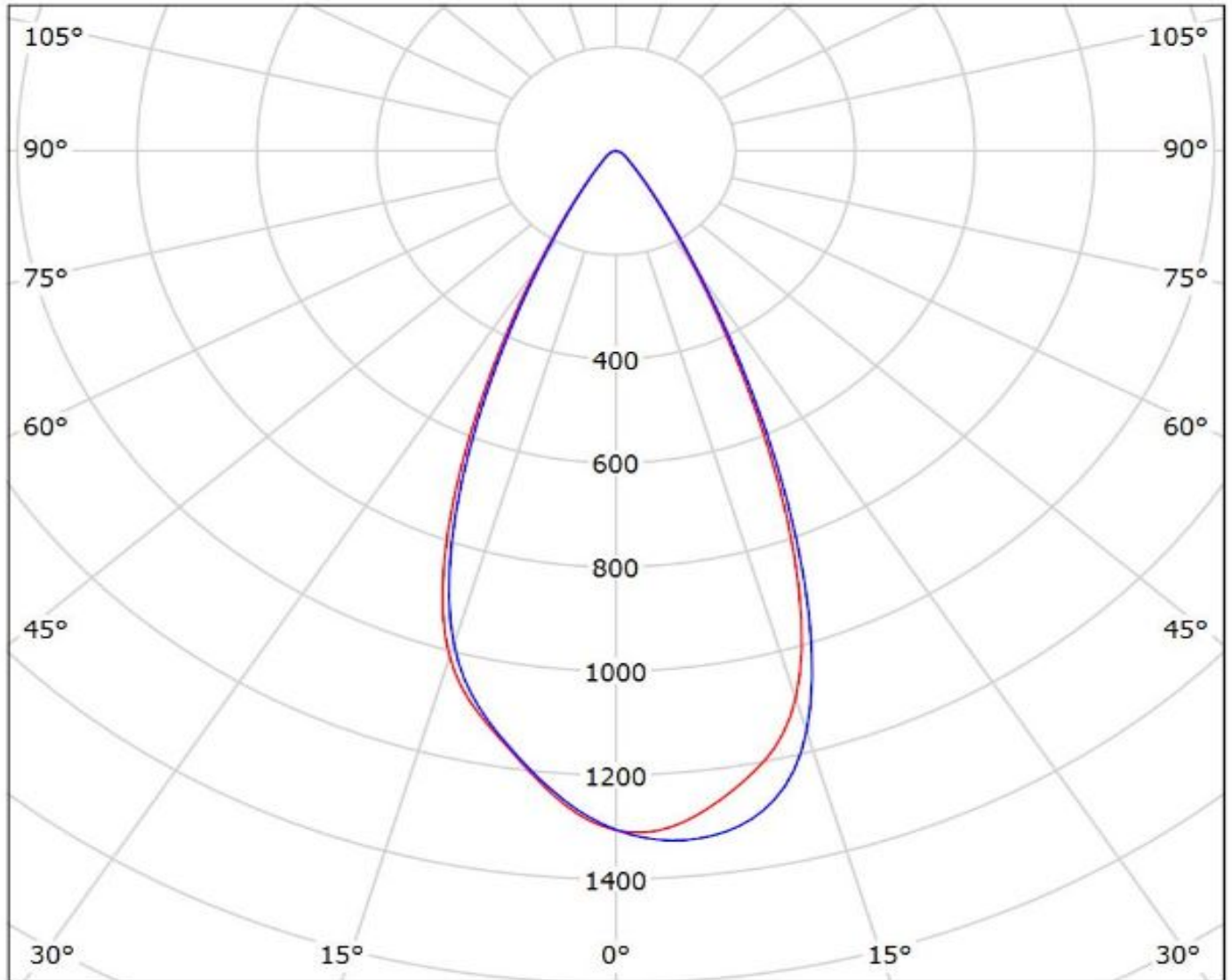

cd/klm

— C0 - C180 — C90 - C270

$\eta = 83\%$

Luminaire: LEDiL Oy C13605_HB-2X2-RW_(Tridonic_Module_RLE_G1)
Lamps: 1 x Tridonic_Module_RLE_G1_4576.03lm@700mA_P=32.0681W_I=0.700A

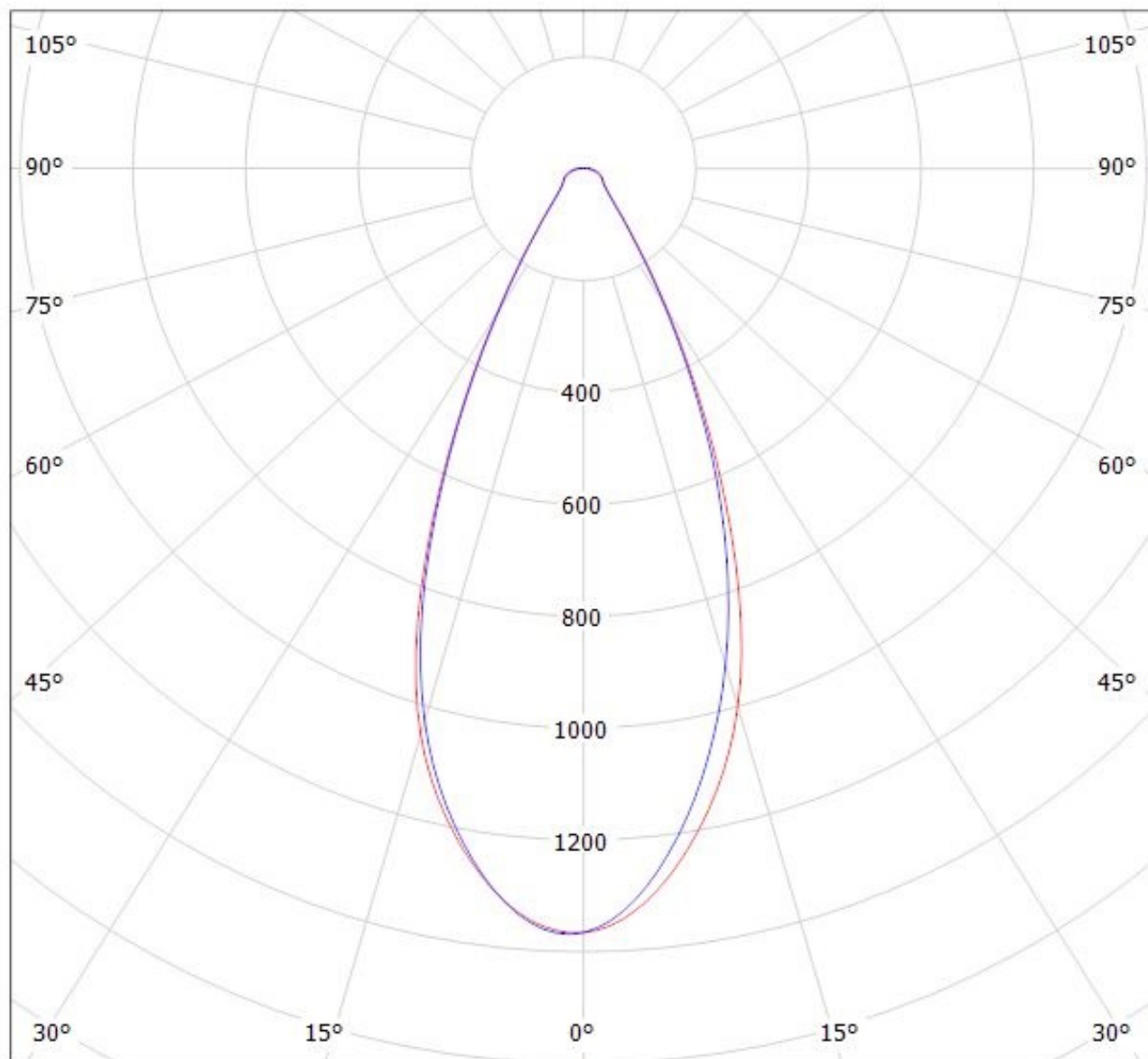

cd/klm

— C0 - C180 — C90 - C270

$\eta = .94\%$

Luminaire: LEDiL Oy C13605_HB-2X2-RW_(Tridonic_Module_RLE_G1)
Lamps: 1 x Tridonic_Module_RLE_G1_4576.03lm@700mA_P=32.0681W_I=0.700A

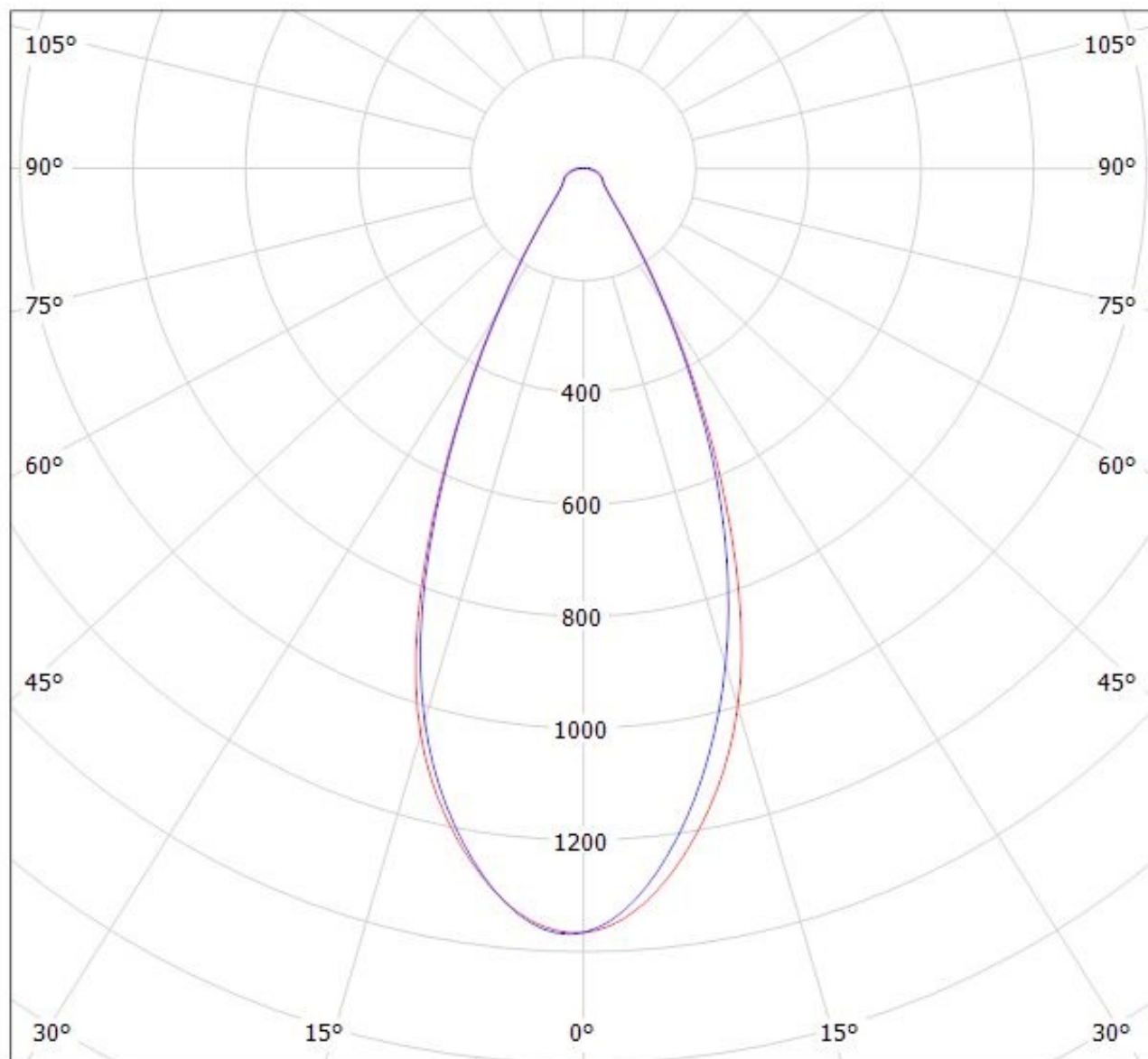

cd/klm

$\eta = .94\%$

— C0 - C180 — C90 - C270

Luminaire: LEDiL Oy C13605_HB-2X2-RW_(Tridonic_Module_RLE_G1)
Lamps: 1 x Tridonic_Module_RLE_G1_2288lm@700mA_P=16W_I=0.700A

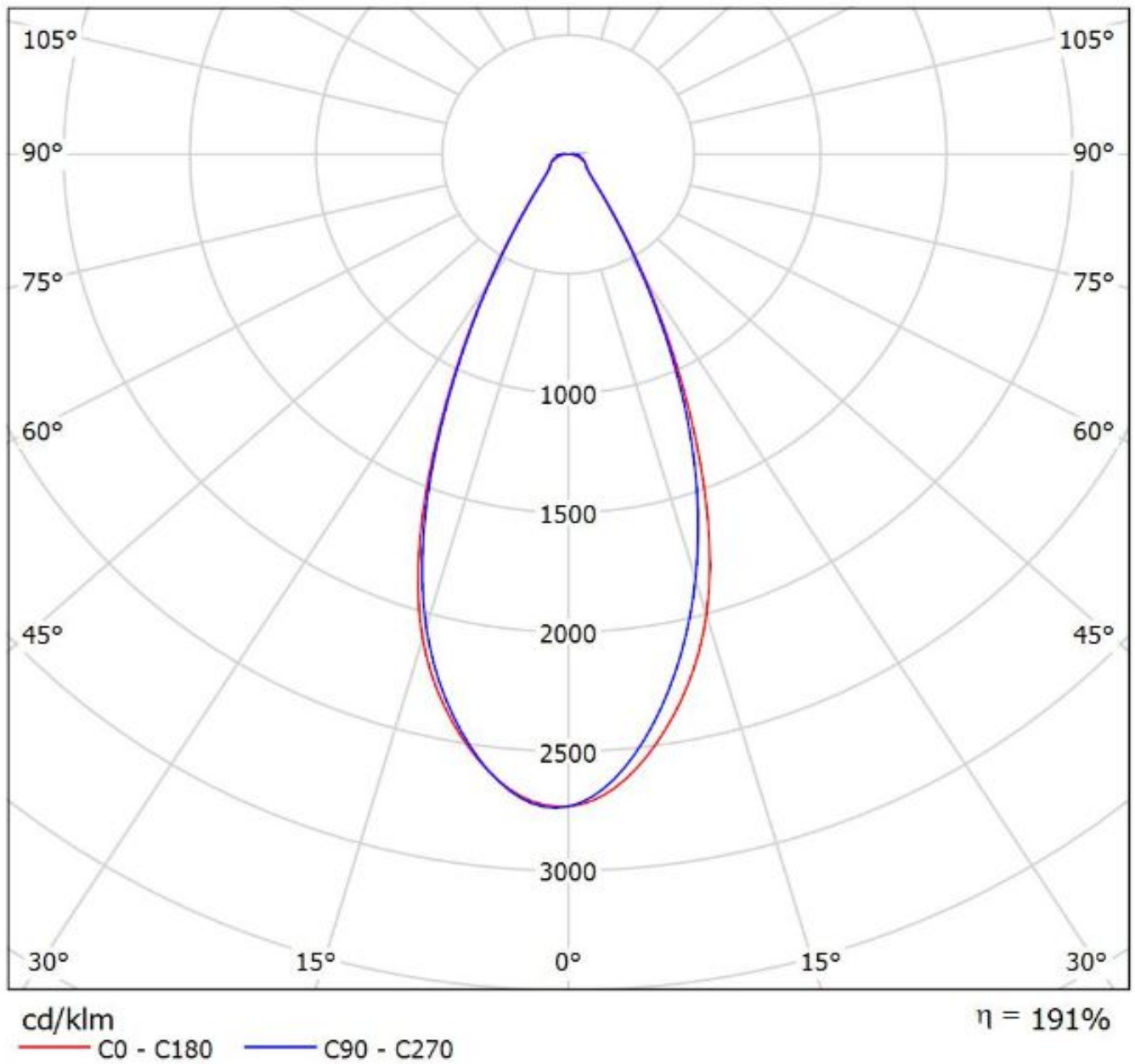

Luminaire: LEDiL Oy C13605_HB-2X2-RW_(Tridonic_Module_RLE_G1)
Lamps: 1 x Tridonic_Module_RLE_G1_2288lm@700mA_P=16W_I=0.700A

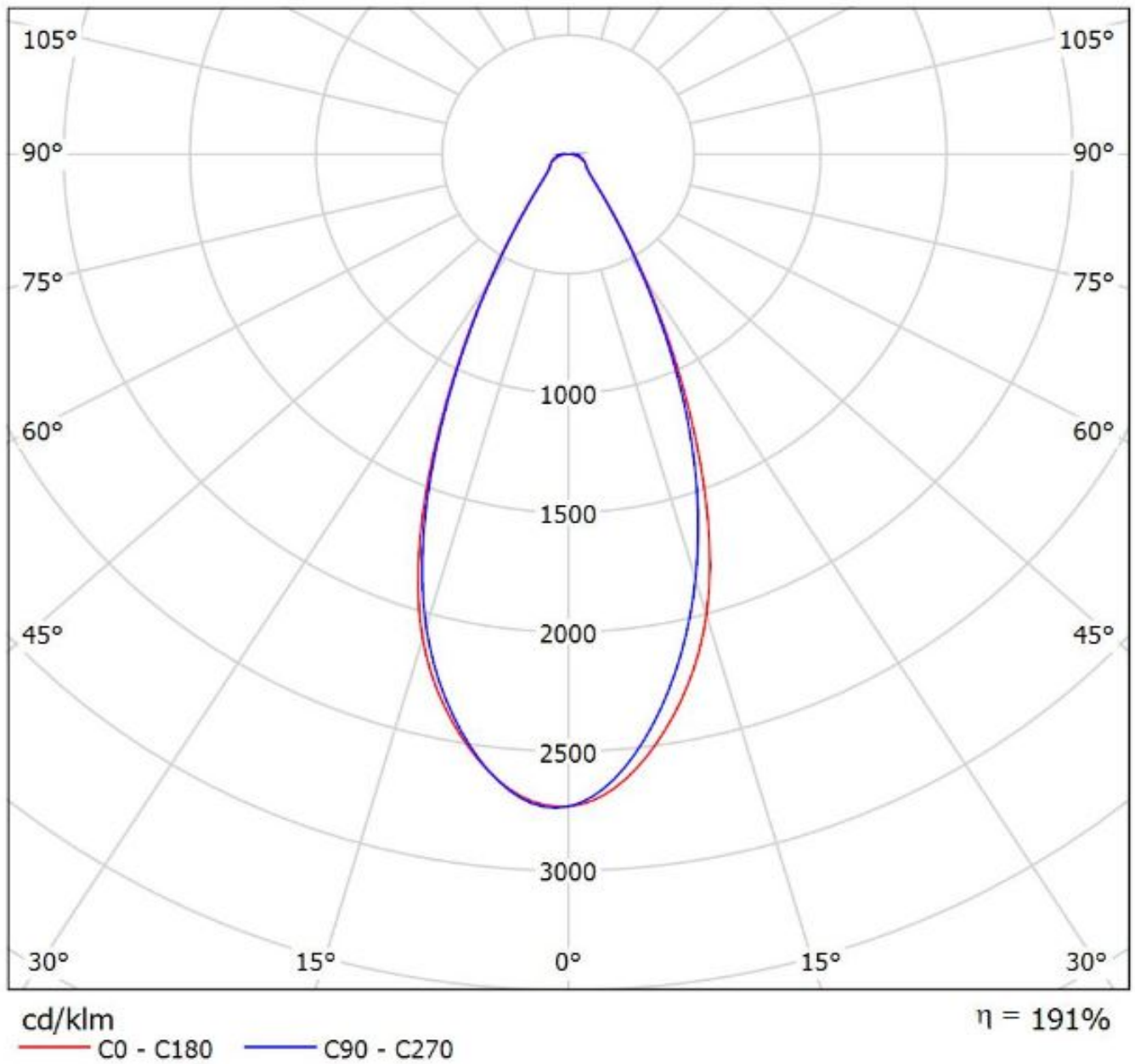

NOTE: The typical divergence will be changed by different color, chip size and chip position tolerance. The typical total divergence is the full angle measured where the luminous intensity is half of the peak value.