

RoHS Compliant & Pb-Free Product

Typical Applications

- Cable Set Top Box
- Commercial and Consumer Systems
- General Purpose Downconverter

Product Description

The RF3334 is an IF LNA/Mixer suitable for downconversion of forward channel control data in a set-top box application. It consists of a single-ended 75Ω terminated LNA, followed by a differential gain control stage with 30dB of analog gain control and a double-balanced mixer. The mixer load is available via pins 10 and 11 should an external filter be required. The mixer output is connected to an IF amplifier that can be configured from 10dB to 40dB gain with an external resistor. The amplifier is capable of 6V pk-pk output into a 1kΩ load.

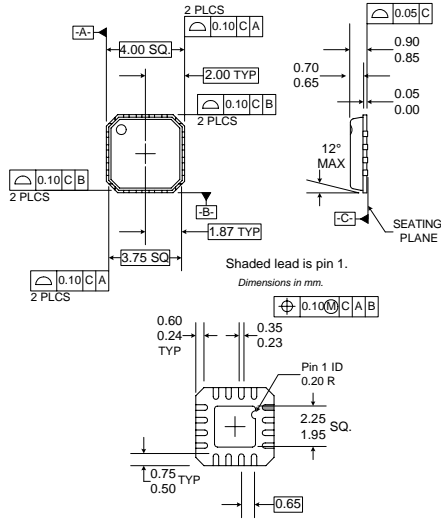

Optimum Technology Matching® Applied

- | | | |
|--|-----------------------------------|---------------------------------------|
| <input type="checkbox"/> Si BJT | <input type="checkbox"/> GaAs HBT | <input type="checkbox"/> GaAs MESFET |
| <input checked="" type="checkbox"/> Si Bi-CMOS | <input type="checkbox"/> SiGe HBT | <input type="checkbox"/> Si CMOS |
| <input type="checkbox"/> InGaP/HBT | <input type="checkbox"/> GaN HEMT | <input type="checkbox"/> SiGe Bi-CMOS |

Package Style: QFN, 16-Pin, 4 x 4

Features

- 30dB RF Gain Control
- 40dB IF Gain Control
- 5dB Max. Noise Figure SSB
- LNA Input Internally Matched to 75Ω
- Single 5V Supply

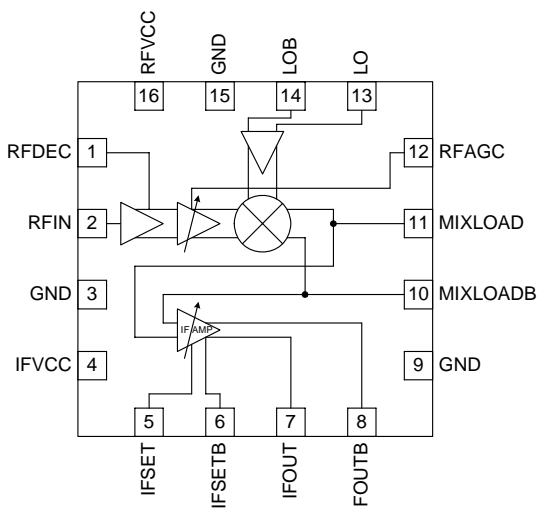

Functional Block Diagram

Ordering Information

RF3334 LNA Mixer
 RF3334PCBA-41X Fully Assembled Evaluation Board

RF Micro Devices, Inc. Tel (336) 664 1233
 7628 Thorndike Road Fax (336) 664 0454
 Greensboro, NC 27409, USA <http://www.rfmd.com>

RF3334

Absolute Maximum Ratings

Parameter	Rating	Unit
Supply Voltage	-0.5 to 7.0	V _{DC}
IF Input Level	500	mV _{pp}
Operating Ambient Temperature	-40 to +85	°C
Storage Temperature	-40 to +150	°C



Caution! ESD sensitive device.

RF Micro Devices believes the furnished information is correct and accurate at the time of this printing. RoHS marking based on EUDirective2002/95/EC (at time of this printing). However, RF Micro Devices reserves the right to make changes to its products without notice. RF Micro Devices does not assume responsibility for the use of the described product(s).

Parameter	Specification			Unit	Condition
	Min.	Typ.	Max.		
DC Specifications					
Supply Voltage	4.75	5	5.25	V	0.5V=Minimum Gain 4.5V=Maximum Gain
Supply Current	20	24		mA	
RFAGC Control Voltage	0.5		4.5	V	
RFAGC Input Impedance		300		kΩ	
AC Specifications					
LNA+AGC+Mixer					
RF Frequency Range		0 to 700		MHz	On-chip signal path is DC-coupled, minimum frequency depends on external AC coupling components.
RF Input 3dB Bandwidth		700		MHz	On-chip signal path is DC-coupled, minimum frequency depends on external AC coupling components.
RF Input Impedance		75		Ω	
RF Input VSWR		1.4			At 100MHz
Mixer Output 3dB Bandwidth		100		MHz	Defined by on-chip first-order low-pass filter
Mixer Output Impedance		300		Ω	Differential
Mixer Output VSWR		1.2			At 100MHz
Maximum Gain	27	30		dB	RFAGC=4.5V
Minimum Gain		-2		dB	RFAGC=0.5V
Output 1 dB Compression		90		dBμV(rms)	Maximum Gain
Input IP3, Maximum Gain		78		dBμV(rms)	LNA Input to Mixer Output
Input IP3, Minimum Gain		79		dBμV(rms)	LNA Input to Mixer Output
Noise Figure			5	dB	SSB, Cascaded LNA, AGC & Mixer
LO					
LO Frequency Range		0 to 800		MHz	Differential
LO Input Impedance		75		Ω	
LO Input VSWR		1.6:1			
LO Input Level	80			dBuV	
LO Bandwidth		800		MHz	
LO Rejection to RF Input		50		dB	
LO Rejection to Input of IF Amplifier		65		dB	
IF Amplifier					
IF Frequency Range		0 to 120		MHz	Differential
Input Impedance		4000		Ω	
Output Impedance		10		Ω	Differential
Differential Voltage Gain					
Gain Set Resistor=2500Ω		10		dB	R1=1kΩ
Gain Set Resistor=140Ω		31		dB	R1=1kΩ
Gain Set Resistor=5Ω		40		dB	R1=1kΩ
IF 3dB Bandwidth	140			MHz	Gain Set=5Ω
Equivalent Input Noise		1.5		μVrms	Gain Set=140Ω
Output Swing		6	8	V _{p-p}	Into 1kΩ load, at 50MHz
Output 1 dB Compression		127		dBμV(rms)	Into 1kΩ load, at 50MHz
Output IP3		137		dBμV(rms)	Into 1kΩ load, at 50MHz

Parameter	Specification			Unit	Condition
	Min.	Typ.	Max.		
Thermal Theta _{JC} Maximum Measured Junction Temperature at DC Bias Conditions		65 95		°C/W °C	V _{CC} =5.25V, V _{RFAGC} =4.5V, I _{CC} =29mA, P _{DISS} =154mW T _{AMB} =+85°C

RF3334

Pin	Function	Description	Interface Schematic
1	RFDEC	External decoupling capacitor for RF single-ended to differential converter.	
2	RF	LNA Input, Internally matched to 75Ω. Should be AC-coupled.	
3	GND	Ground.	
4	IFVCC	5V supply for IF section.	
5	IFSET	IF Gain select. The resistance between this pin and pin 6 (IFSETB) determines the gain of the IF amplifier. Maximum gain is achieved by placing a short circuit between the pins. Larger values of resistance will reduce the IF gain according to the following equation where R is the value of resistance between pins 5 and 6. $IF\ Gain = 20 \log(1600/(R=75)) 15.$	
6	IFSETB	Complementary IF Gain select.	
7	IFOUT	IF Amplifier Output. Differential output of the IF amplifier. The differential load across this pin and pin 8 (IFOUTB) should be 1kΩ or greater for optimal performance. The differential output impedance across this pin and pin 8 is 10Ω.	
8	IFOUTB	Complementary IF Amplifier Output.	
9	GND	Ground.	
10	MIXLOADB	Complementary Mixer load.	
11	MIXLOAD	Differential output of the RF mixer. A resonant load should be applied to this pin and pin 10 (MIXLOADB) that will act as a bandpass filter at the desired IF frequency. VCC should be supplied to this pin via an inductor or a resistor. Use of a resistor will degrade intermodulation performance.	

RF3334

Pin	Function	Description	Interface Schematic
12	RFAGC	RF Gain select voltage input. The voltage applied to this pin sets the gain of the RF amplifier. The voltage applied to this pin should be between 0.5V and 4.5V. The RF gain characteristic is such that 0.5V yields a gain of -2dB and 4.5V yields a gain of +30dB as measured from the input of the LNA to the output of the mixer stage.	
13	LO	Differential LO Input. This pin and pin 14 (LOB) are the differential LO inputs. This input should be AC-coupled. The differential input impedance across pins 13 and 14 is 75Ω. The LO may be driven single ended but will require a higher drive level. If a single ended LO is applied, pin 14 should be AC-coupled to ground.	
14	LOB	Complementary LO Input. Should be AC-coupled.	
15	GND	Ground.	
16	RFVCC	5V supply for RF section.	
GND	Paddle	Backside of package should be connected to ground.	

RF3334

Pin-Out

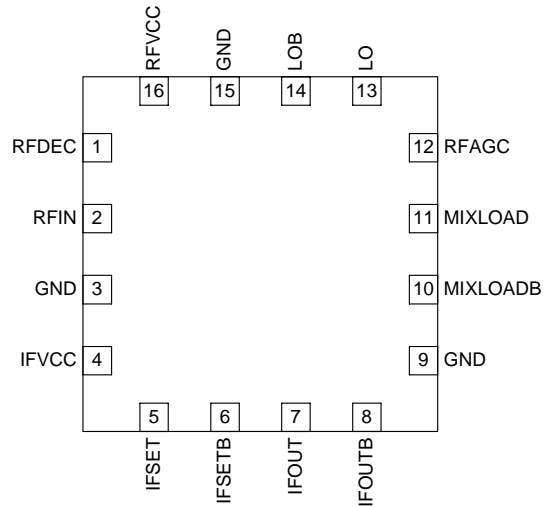

Application Schematic

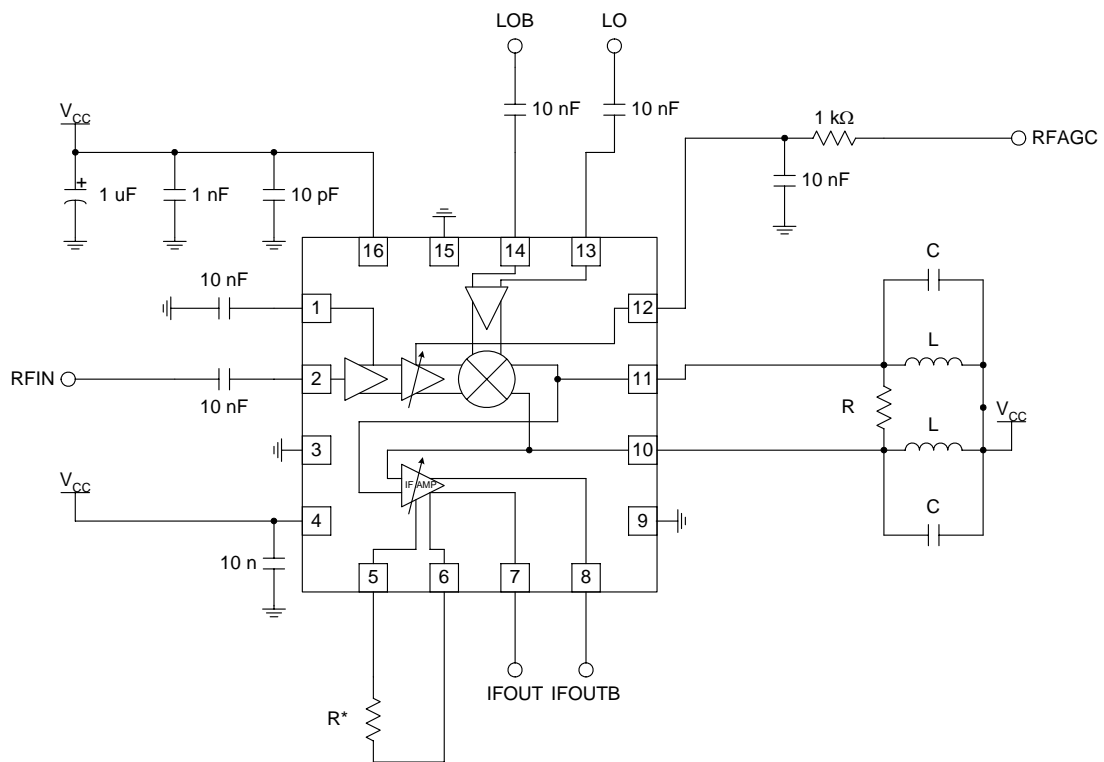

Evaluation Board Layout
Board Size 2.0" x 2.0"
Board Thickness 0.032", Board Material FR-4, Multi-layer

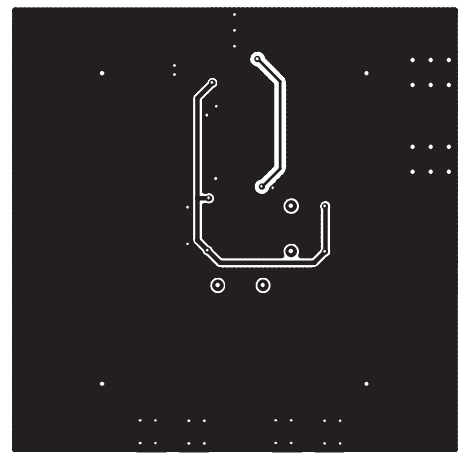
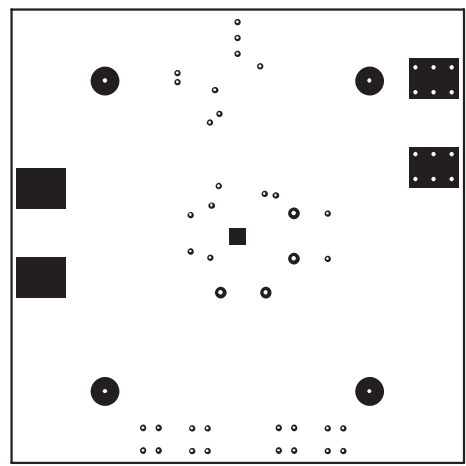
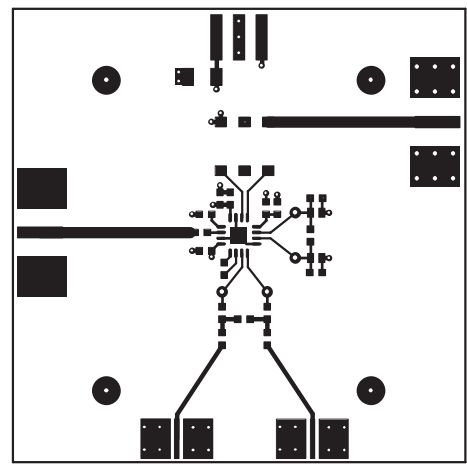
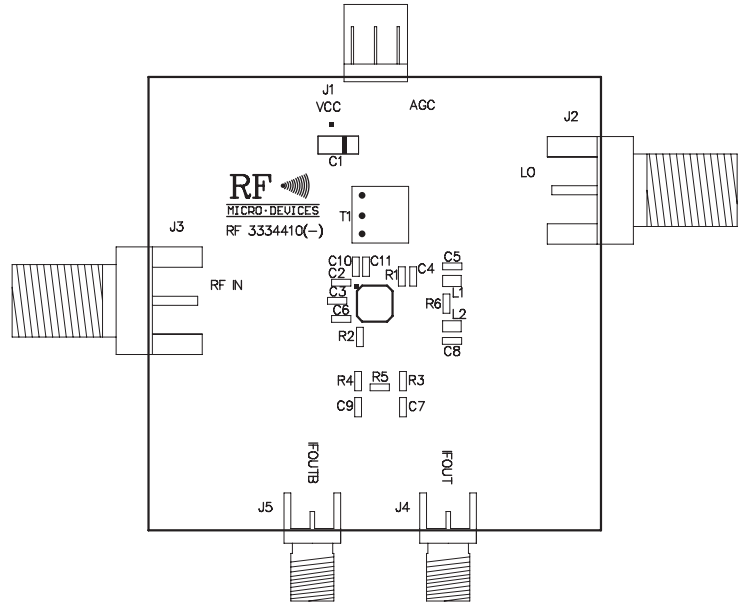

RF3334

RF Input, Temp = +25°C

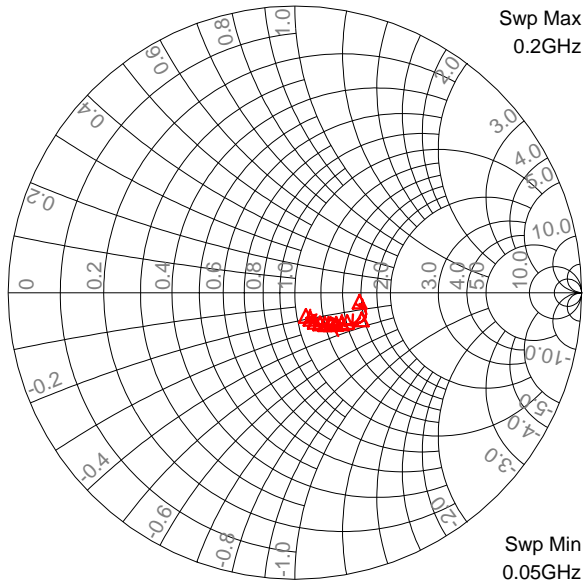

LO Input, Temp = +25°C

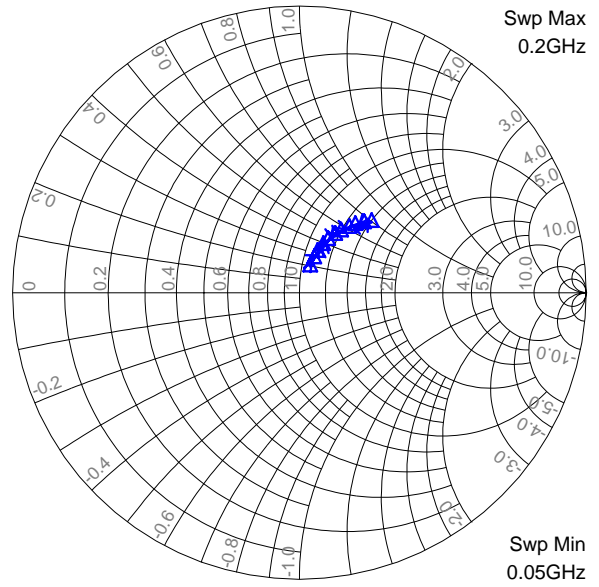

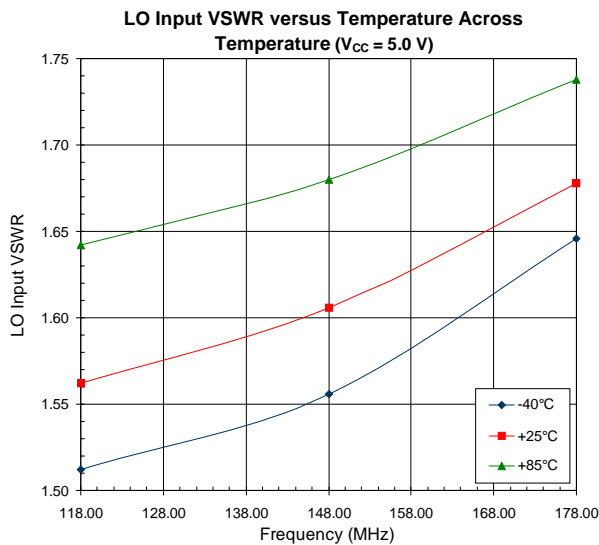
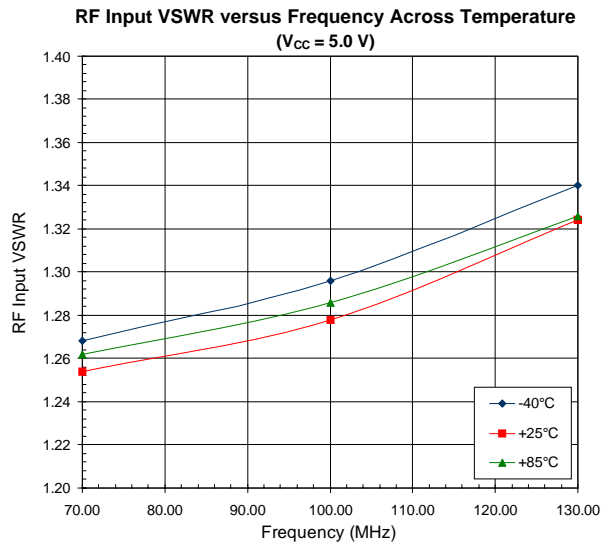
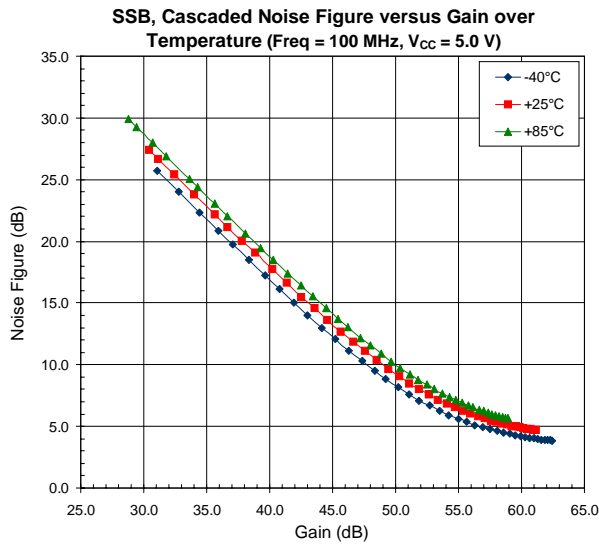
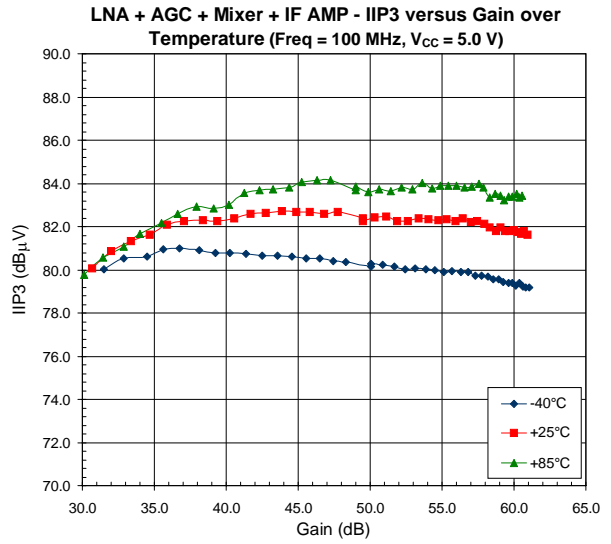
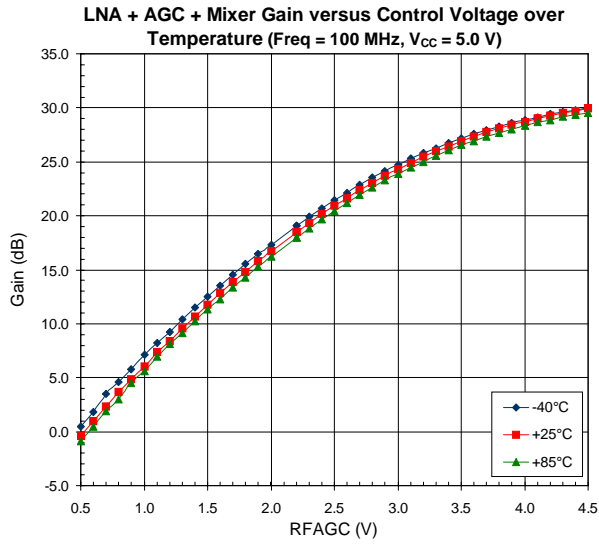

PCB Design Requirements

PCB Surface Finish

The PCB surface finish used for RFMD's qualification process is electroless nickel, immersion gold. Typical thickness is 3μinch to 8μinch gold over 180μinch nickel.

PCB Land Pattern Recommendation

PCB land patterns are based on IPC-SM-782 standards when possible. The pad pattern shown has been developed and tested for optimized assembly at RFMD; however, it may require some modifications to address company specific assembly processes. The PCB land pattern has been developed to accommodate lead and package tolerances.

PCB Metal Land Pattern

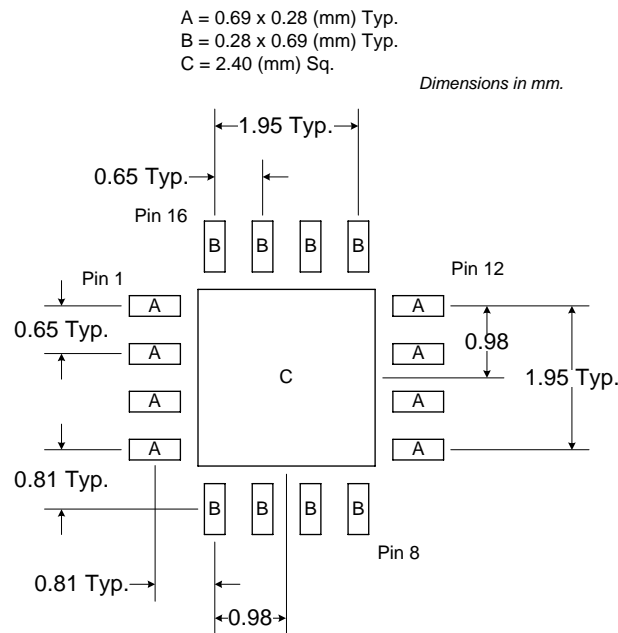

Figure 1. PCB Metal Land Pattern (Top View)

PCB Solder Mask Pattern

Liquid Photo-Imageable (LPI) solder mask is recommended. The solder mask footprint will match what is shown for the PCB metal land pattern with a 2mil to 3mil expansion to accommodate solder mask registration clearance around all pads. The center-grounding pad shall also have a solder mask clearance. Expansion of the pads to create solder mask clearance can be provided in the master data or requested from the PCB fabrication supplier.

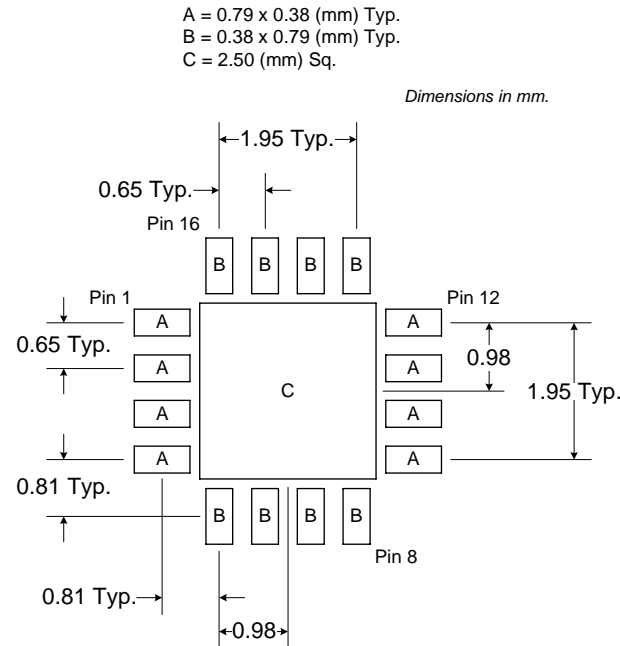

Figure 2. PCB Solder Mask Pattern (Top View)

Thermal Pad and Via Design

The PCB land pattern has been designed with a thermal pad that matches the die paddle size on the bottom of the device.

Thermal vias are required in the PCB layout to effectively conduct heat away from the package. The via pattern has been designed to address thermal, power dissipation and electrical requirements of the device as well as accommodating routing strategies.

The via pattern used for the RFMD qualification is based on thru-hole vias with 0.203mm to 0.330mm finished hole size on a 0.5mm to 1.2mm grid pattern with 0.025mm plating on via walls. If micro vias are used in a design, it is suggested that the quantity of vias be increased by a 4:1 ratio to achieve similar results.

RF3334