

i.MX 7ULP Applications Processor—Industrial

The i.MX 7ULP product family members are optimized for power-sensitive applications benefiting from NXP's Heterogeneous Multicore Processing (HMP) architecture. Achieving an efficient balance between processing power and deterministic processing needs, the i.MX 7ULP is an asymmetric processor consisting of two separate processing domains: an application domain and a real-time domain. The application domain is built around an ARM® Cortex®-A7 processor with an ARM NEON™ SIMD engine and floating point unit (FPU) and is optimized for rich OS based applications. The real-time domain is built around an ARM Cortex-M4 processor (with FPU) optimized for lowest possible leakage. Both domains are completely independent, with separate power, clocking, and peripheral domains, but the bus fabric of each domain is tightly integrated for efficient communication. The part is streamlined to minimize pin count, enabling small packages and simple system integration.

MCIMX7U5CVP06SD
MCIMX7U3CVP06SD

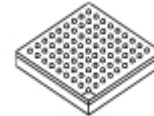

Plastic package: BGA 14x14mm, 0.5mm pitch

i.MX 7ULP features

Feature type	Application processor domain	Real-time processor domain
ARM Processor	Cortex®-A7	Cortex®-M4
	<ul style="list-style-type: none"> Nominal (RUN) frequency: 500 MHz Overdrive (HSRUN) frequency: 650 MHz Very Low Power Run (VLPR) frequency: 48 MHz 	<ul style="list-style-type: none"> Nominal (RUN) frequency: 120 MHz Overdrive (HSRUN) frequency: 200 MHz Very Low Power Run (VLPR) frequency: 48 MHz
	32 KB instruction and data caches	Optimized for lowest leakage current
	256 KB L2 cache	FPU
	NEON™ SIMD engine	MPU
	FPU	—
On-chip memory	256 KB of RAM	256 KB of tightly coupled RAM allocated into 32 KB switchable blocks
	—	8 KB of OTP memory
External memory interfaces	16/32-bit LPDDR2/LPDDR3 interface running at 271.5 MHz	Serial flash interface supporting x4 and x8 IOs
	eMMC 5.0 interface	—
Security	Secure boot	Secure boot

Table continues on the next page...

i.MX 7ULP features (continued)

Feature type	Application processor domain	Real-time processor domain
	Signing and encrypt/decrypt engines (CAAM)	Encrypt/decrypt engines (LTC)
	Simple tamper detection	—
Serial peripherals	Four I2C Fast mode plus	Four I2C Fast mode plus
	SD 3.0/MMC 5.0	FlexI/O
	Four UARTs with flow control	Four UARTs with flow control
	Two LPSPI peripherals	Two LPSPI peripherals
Timers	Four 32-bit general-purpose timers with capture and compare; one 64-bit timer	Four 32-bit general purpose-timers with capture and compare; one 64-bit timer
	Watchdog timer	Watchdog timer

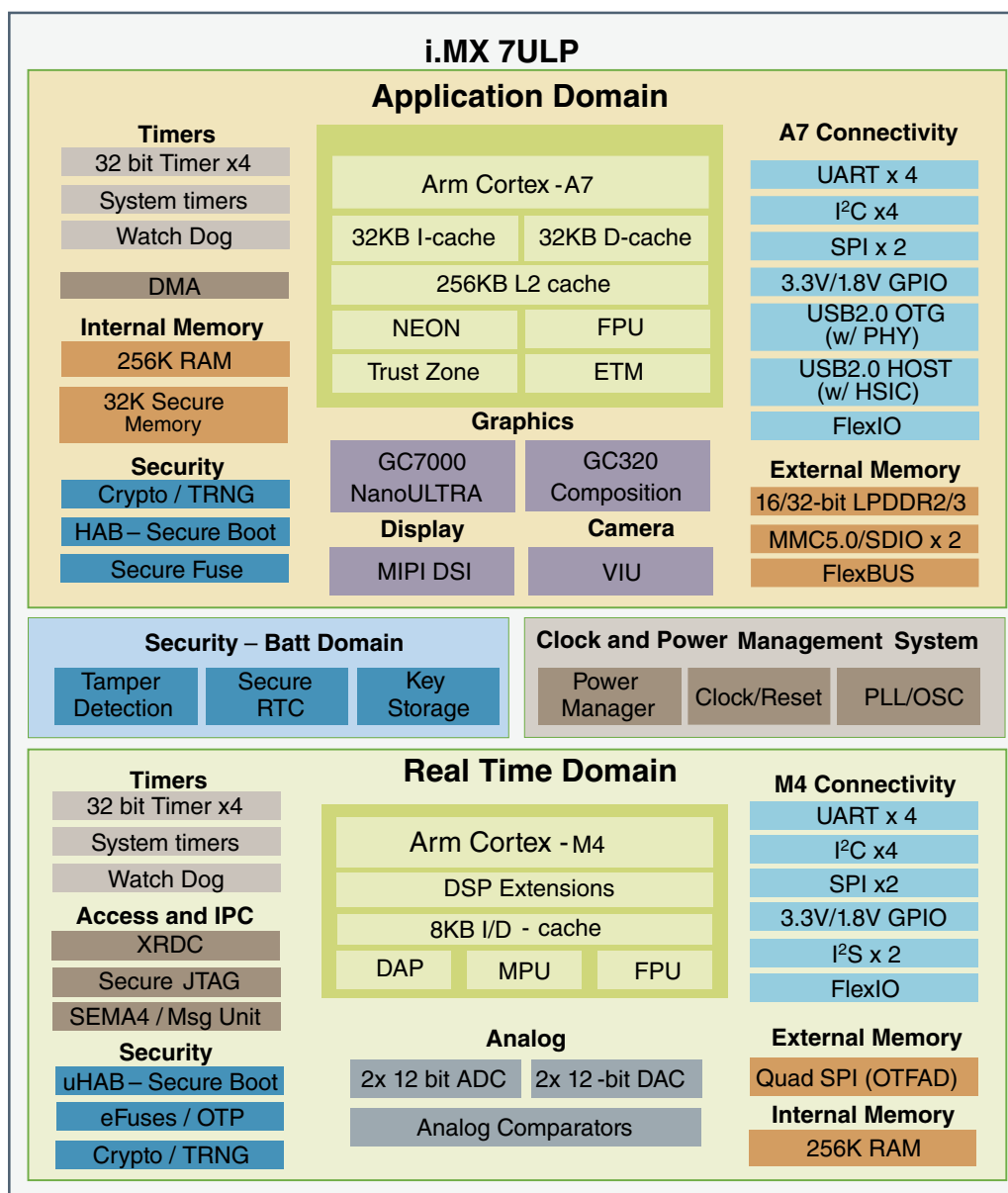

Figure 1. i.MX 7ULP Block Diagram

The following table provides examples of orderable sample part numbers covered by this data sheet.

Ordering information

Part Number	Options	Cortex-A7 Speed Grade	Cortex-M4 Speed Grade	Qualification Tier	Junction Temperature Range	Package
MCIMX7U5CVP06SD	GPU-2D, GPU-3D supported	650 MHz	200 MHz	Industrial	-40 to +105 °C	14 mm x 14 mm, 0.5 mm pitch BGA, Package code "VP"
MCIMX7U3CVP06SD	No GPU	650 MHz	200 MHz	Industrial	-40 to +105 °C	14 mm x 14 mm, 0.5 mm pitch BGA, Package code "VP"

The following figure describes the part number nomenclature so users can identify the characteristics of the specific part number.

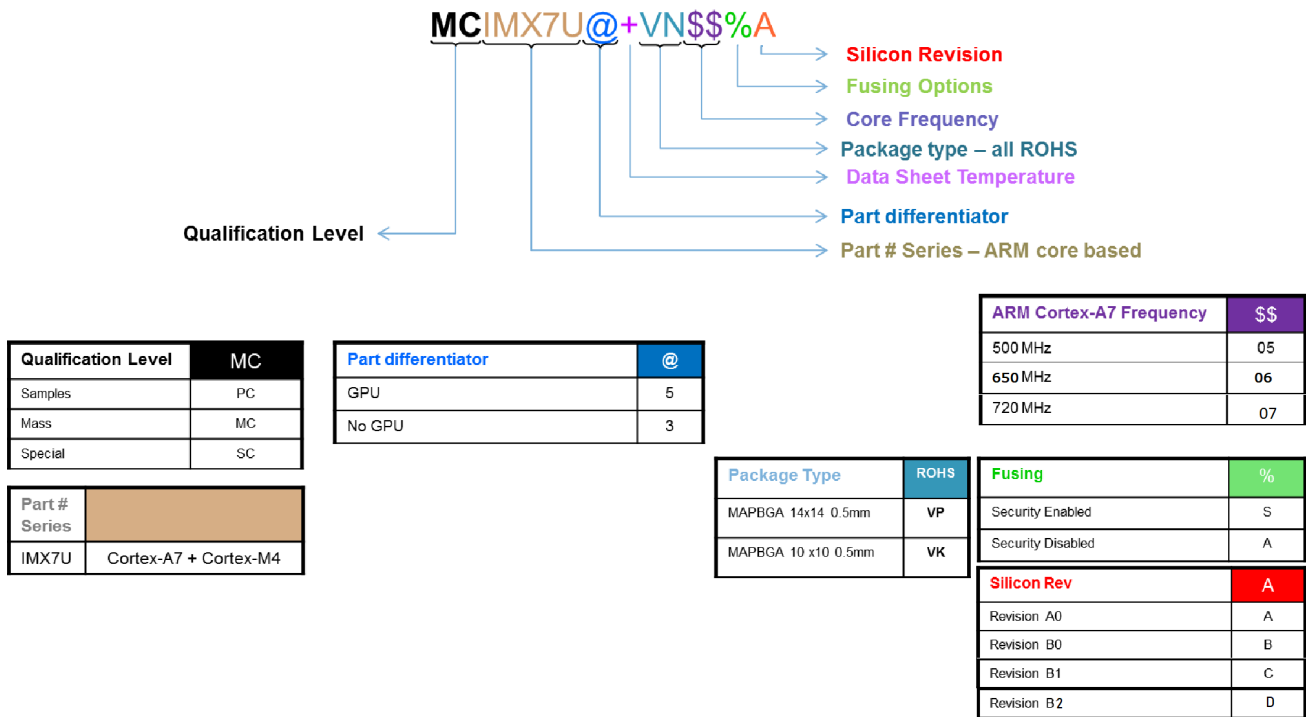

Figure 2. i.MX 7 Family Part Number Definition

Related Resources

Type	Description
Reference Manual	The <i>i.MX 7ULP Applications Processor Reference Manual</i> contains a comprehensive description of the structure and function (operation) of the SoC.
Data Sheet	The Data Sheet includes electrical characteristics and signal connections.
Chip Errata	The chip mask set errata provides additional or corrective information for a particular device mask set.
Package drawing	Package dimensions are provided in Package information and contact assignments

The power mode acronyms used throughout this document are defined as follows.

Power mode acronym table

Power mode acronym	Power mode name
HSRUN	High-speed run mode
RUN	Nominal speed run mode
VLPR	Very low power run mode
PSTOP	Partial stop mode

Table continues on the next page...

Power mode acronym table (continued)

Power mode acronym	Power mode name
STOP	Stop mode
VLPS	Very low power stop mode
LLS	Low leakage stop mode
VLLS	Very low leakage stop mode

For details on each of these operating modes, see the i.MX 7ULP Applications Processor Reference Manual (IMX7ULPRM).

Table of Contents

1	i.MX 7ULP modules list.....	7		
2	Clocking.....	21		
2.1	Introduction.....	21		
2.2	Clock distribution.....	22		
2.3	External clock sources.....	23		
2.4	Oscillators.....	23		
2.5	Internal clock sources.....	23		
3	Application domain (implementing ARM Cortex-A7).....	24		
3.1	Memory system—application domain.....	24		
3.1.1	Internal memory (application domain).....	24		
3.1.2	Multi Mode DDR Controller (MMDC).....	24		
3.1.3	eMMC.....	25		
3.2	Peripherals—application domain.....	25		
3.2.1	Graphics processor human machine interfaces.....	25		
3.2.2	Security—application domain.....	26		
3.2.3	Timers—application domain.....	27		
3.2.4	Connectivity and communications—applications domain.....	27		
4	Real-time domain (implementing ARM Cortex-M4).....	28		
4.1	Memory system—real-time domain.....	28		
4.1.1	Internal memory—real-time domain.....	28		
4.1.2	QuadSPI flash.....	28		
4.2	Peripherals—real-time domain.....	28		
4.2.1	Analog—real-time domain.....	28		
4.2.2	Connectivity and communications—real-time domain.....	29		
5	System control modules.....	29		
5.1	JTAG—system control.....	29		
5.2	JTAG device identification register.....	29		
5.3	Oscillators and PLLs.....	30		
5.3.1	System oscillator (SYS OSC).....	30		
5.3.2	Real-Time Clock Oscillator (RTC OSC).....	30		
5.3.3	USB PLL.....	30		
5.3.4	Fixed Frequency PLL (Fixed-freq PLL).....	30		
5.3.5	Fractional-N PLL (FracN PLL).....	31		
5.4	Power Management.....	31		
5.4.1	Digital PMC.....	31		
5.4.2	Analog power management controller (Analog PMC).....	31		
6	i.MX 7ULP LDO Bypass versus LDO-enabled modes.....	32		
6.1	Real-time domain LDO Enabled mode.....	32		
6.2	Application domain LDO Enabled mode.....	32		
6.3	Application domain LDO BYPASS mode.....	32		
7	System specifications.....	33		
7.1	Ratings.....	33		
7.1.1	Thermal handling ratings.....	33		
7.1.2	Moisture handling ratings.....	33		
7.1.3	ESD handling ratings.....	33		
7.1.4	Absolute maximum ratings.....	34		
7.1.5	Recommended operating conditions—system.....	35		
7.1.6	Estimated maximum supply currents.....	39		
7.2	System clocks.....	40		
7.2.1	Clock modules.....	40		
7.2.2	Core, platform, and system bus clock frequency limitations.....	43		
7.2.3	Peripheral clock frequencies.....	44		
7.2.4	PLL PFD output.....	47		
7.2.5	Audio tunable clock.....	48		
7.3	Power sequencing—system.....	49		
7.3.1	Power-on sequencing.....	49		
7.3.2	Power-off sequencing.....	50		
7.4	Requirements for unused interfaces.....	50		
7.5	Electrical Characteristics and Thermal Specifications.....	51		
7.5.1	AC electrical characteristics.....	51		
7.5.2	Nonswitching electrical characteristics.....	52		
7.5.3	Switching electrical characteristics.....	53		
7.5.4	Debug and trace modules.....	55		
7.5.5	Thermal specifications.....	59		
8	Specifications—application domain.....	60		
8.1	Peripheral operating requirements and behaviors.....	60		
8.1.1	DDR timing—application domain.....	60		
8.1.2	Ultra-high-speed SD/SDIO/MMC host interface (uSDHC) AC timing—application domain.....	60		
8.1.3	Flexbus switching specifications.....	66		
8.1.4	Display, Video, and Audio Interfaces.....	69		
8.1.5	Timer specifications—application domain.....	70		
8.1.6	Connectivity and communications specifications—application domain.....	70		
9	Specifications—real-time domain.....	79		
9.1	Power sequencing—real-time domain.....	79		
9.2	Peripheral operating requirements and behaviors—real-time domain.....	80		
9.2.1	QuadSPI AC specifications.....	80		
9.2.2	Analog modules.....	84		
9.2.3	Timer specifications—real-time domain.....	92		
9.2.4	Connectivity and communications specifications—real-time domain.....	92		
10	Package information and contact assignments.....	96		
10.1	BGA, 14 x 14 mm, 0.5 mm pitch (VP suffix).....	96		
10.1.1	14 x 14 mm package case outline.....	96		
10.1.2	14 x 14 mm, 0.5 mm pitch, ball map.....	98		
10.1.3	14 x 14 mm power supply and functional contact assignments.....	100		
11	Revision History.....	108		

1 i.MX 7ULP modules list

The i.MX 7ULP applications processor contains a variety of digital and analog modules. The following table describes these modules in alphabetical order.

In the Domain column in this table:

- AD = Application Power Domain (primarily controlled by the Cortex-A7)
- RT = Real-Time Power Domain (primarily controlled by the Cortex-M4)
- VBAT = RTC/VBAT power domain Real-Time Domain
- DGO = “always-on” DGO power domain
- SYS = system-level functions that are implemented separately from the domains listed above.

Table 1. i.MX 7ULP modules list

Block Name	Block Mnemonic	Subsystem	Power Domain	Brief description
AMBA Network Interconnect Crossbar	NIC0-1	DMA and Bus Fabrics	AD	The AMBA Network Interconnect Crossbar (NIC) is a highly configurable and high performance AMBA-compliant network infrastructure which arbitrates between multiple AXI or AHB masters to grant access to internal or external memories or other slave devices. It supports connectivity between several slave and master ports for parallel processing. It uses a hybrid round-robin arbitration scheme and contains frequency converters, data width converters, bus protocol converter, and AXI channel buffers.
Analog PMC	Analog PMC	Power Management	SYS	The Analog PMC consists of voltage/current references, core logic supply regulators, memory supply regulators, Back and Forward Biasing regulators, monitors and power switches, etc. There are two Analog PMC subsystems in i.MX 7ULP, one associated with the M4 power domain and the other with the A7 power domain.
Analog-to-Digital Converter	ADC0-1	Analog	RT	Analog-to-Digital Converter (ADC) is a 12-bit resolution, successive approximation analog to digital converter. The ADC module supports up to 16 single-ended external analog inputs. It outputs 12-bit, 10-bit, or 8-bit digital signal in right-justified unsigned

Table continues on the next page...

Table 1. i.MX 7ULP modules list (continued)

Block Name	Block Mnemonic	Subsystem	Power Domain	Brief description
				format. The ADC can achieve 1 microsecond conversion rate.
Asynchronous Wakeup Interrupt Controller	AWIC	System Control	RT	The Asynchronous Wakeup Interrupt Controller (AWIC) module is capable of interrupt detection and wake-up of a processor when it is in low power mode.
Bit Manipulation Engine	BME	Multicore peripherals and resource domain control submodules	RT	The Bit Manipulation Engine (BME) provides hardware support for atomic read-modify-write memory operations to the peripheral address space. This architectural capability is also known as "decorated storage" as it defines a mechanism for providing additional semantics for load and store operations to memory-mapped peripherals beyond just the reading and writing of data values to the addressed memory locations.
Comparator	CMP0-1	Analog	DGO	The (CMP) module provides a circuit for comparing two analog input voltages. The comparator circuit is designed to operate across the full range of the supply voltage (rail to rail operation).
Cross Trigger Matrix	CTM	Debug	RT	Cross Trigger Matrix (CTM) is a component of the Embedded Cross Trigger (ECT), which is key in the multicore debug strategy. The CTM receives signals from various sources (i.e. cores and peripherals) and propagates or routes them to the different debug resources of the SoC. Those debug resources can include time stamping capability, real-time trace, triggers and debug interrupts.
Cryptographic Acceleration and Assurance	CAAM	Security	AD	Cryptographic Acceleration and Assurance Module (CAAM) is a multifunction accelerator that supports the cryptographic functions common in many security protocols. This includes AES128, AES256, DES, 3DES, SHA1, SHA224, SHA256, and a random number generator with a true entropic seed. CAAM includes a DMA engine that is descriptor based to reduce processor-accelerator interaction. Security feature clear keys and memories when on-chip security monitor detects tampering. The Secure RAM is implemented and provides secure storage of sensitive information

Table continues on the next page...

Table 1. i.MX 7ULP modules list (continued)

Block Name	Block Mnemonic	Subsystem	Power Domain	Brief description
				both in on-chip RAM and in off-chip, nonvolatile memory. For details, see the <i>i.MX 7ULP Security Reference Manual</i> .
Cyclic Redundancy Check	CRC	Connectivity and Communications	RT	The Cyclic Redundancy Check (CRC) module is a hardware CRC generator circuit using 16/32-bit shift register. The CRC module supports error detection for all single, double, odd, and most multi-bits errors, programmable initial seed value, and optional feature to transpose input data and CRC result via transpose register.
Debug Access Port	DAP	Debug	RT	Debug Port Access (DAP) provides debugger access to on-chip system resources via the SWJ-DP port. The DAP provides internal system access to A7 Debug Port, M4 Debug Port, System Bus, JTAG controller, and SoC Control and Status. The DAP also enables system access to CoreSight debug subsystem through the APBIC port.
Digital PMC	Digital PMC	Power Management	SYS	The Digital PMC module allows user software to control power modes of the chip and to optimize power consumption for the level of functionality needed. There are two instances of Digital PMC on this device, one for each main power domain.
Digital-to-Analog Converter	DAC0-1	Analog	RT	Digital-to-Analog Converter (DAC) is the 12-bit resolution digital-to-analog converters with programmable reference generator output. The output of the DAC can be placed on an external pin or set as one of the inputs to the analog comparator or ADC. The DAC is capable of achieving 1 ms conversion rate for high-speed signals and 2 ms conversion rate for low-speed signals.
Direct Memory Access	DMA0-1	DMA and Bus Fabrics	AD, RT	Direct Memory Access (DMA) is capable of performing complex data transfers with minimal intervention from a host processor. Each DMA module supports 32 DMA channels. The transfer control descriptors for each of the 32 channels locate in system memory. DMA0 is in the real-time domain. DMA1 is in the application domain.

Table continues on the next page...

Table 1. i.MX 7ULP modules list (continued)

Block Name	Block Mnemonic	Subsystem	Power Domain	Brief description
Direct Memory Access Multiplexer	DMAMUX0-1	DMA and Bus Fabrics	AD, RT	The Direct Memory Access Multiplexer (DMAMUX) module routes DMA sources, called slots, to any of the supported DMA channels. DMAMUX0 is in the real-time domain. DMAMUX1 is in the application domain.
Embedded Trace FIFO	ETF	Debug	RT	The Embedded Trace FIFO (ETF) consists of a formatter, control, and the trace RAM. It is a configuration of the Trace Memory Controller (TMC). The ETF will have a memory size of 16Kbytes. The ETF and associated memory should be connected in the system such that it will retain the information through a warm or cold reset of the system. This is to allow for debug information to be retained for debugging problems that may arise and cause a reset of the system.
Embedded Trace Router	ETR	Debug	RT	The ETR is a trace sink that redirects the trace stream onto the AXI bus to external storage. It can utilize a single contiguous region or a scattered allocation of blocks for a circular buffer. Reading of the AXI based trace buffer can either be done directly over AXI from a normal bus master. The ETR is a configuration option of the TMC as is the ETF.
Extended Resource Domain Controller	XRDC	Multicore Peripherals and Resource Domain Control submodules	AD, RT	The Extended Resource Domain Controller (XRDC) provides an integrated, scalable architectural framework for access control, system memory protection and peripheral isolation. It allows software to assign chip resources (like processor cores, non-core bus masters, memory regions and slave peripherals) to processing domains, to support enforcement of robust operational environments. The XRDC implementation is distributed across multiple submodules instantiated throughout the device.
External Bus Interface	FlexBus	Memories and Memory Controllers	AD	The External Bus Interface (FlexBus) module provides external memory expansion and provides connection to external peripherals with a parallel, memory-mapped interface. The FlexBus supports asynchronous and synchronous interface to external ROM, NOR flash, SRAM, PSRAM,

Table continues on the next page...

Table 1. i.MX 7ULP modules list (continued)

Block Name	Block Mnemonic	Subsystem	Power Domain	Brief description
				programmable logic devices and other memory-mapped slave devices.
External Watchdog Monitor	EWM	Timers	RT	The External Watchdog Monitor (EWM) module is designed to monitor external circuits, as well as the software flow. This provides a back-up mechanism to the internal WDOG that can reset the system. The EWM differs from the internal WDOG in that it does not reset the system. The EWM, if allowed to time-out, provides an independent trigger pin that when asserted resets or places an external circuit into a safe mode.
Fast Internal Reference Clock	FIRC	Clock Sources and Control	SYS	The Fast Internal Reference Clock (FIRC) module is an internal oscillator that can generate a reference clock in the range from 48 MHz to 60 MHz. The FIRC output clock is used as a reference to the SCG module, and it is also used as a clock option to most on-chip modules.
Fixed-frequency PLL	Fixed-Freq PLL (PLL0)	Clock Sources and Control	SYS	The Fixed-frequency PLL is the same as the USB PLL. In addition to the main clock output, this PLL also includes 4 Phase Fractional Dividers (PFDs) that can generate other clock frequencies. There is one instance of the Fixed-freq PLL (PLL0) provides clocks for M4 core and buses and peripherals in the Real-time domains.
Flexible Input/Output	FLEXIO0-1	Connectivity and Communications	AD, RT	The Flexible Input/Output (FlexIO) module is capable of supporting a wide range of protocols including, but not limited to: UART, I2C, SPI, I2S, camera interface, display interface, PWM waveform generation, etc. FlexIO0 is in the real-time domain. FlexIO1 is in the application domain.
Fractional-N PLL	Frac-N PLL (PLL1-3)	Clock Sources and Control	SYS	The Fractional-N (Frac-N) PLL can generate an output clock of 528 MHz from a supported reference clock. In addition to the main clock output, this PLL also includes up to 4 Phase Fractional Dividers (PFDs) that can generate other clock frequencies. This PLL also supports tunable clock for audio applications.
GC320 Composition Processing Core	GPU-2D	Multimedia	AD	Vivante GC320 is a Composition Processing Core (CPC) GPU. It

Table continues on the next page...

Table 1. i.MX 7ULP modules list (continued)

Block Name	Block Mnemonic	Subsystem	Power Domain	Brief description
				supports user interface rendering and performs functions like blending, filtering, rotation, overlay, resizing, transparency, and other dynamic effects.
GC7000 Nano Ultra Graphic Processing Unit	GPU-3D	Multimedia	AD	i.MX 7ULP integrates the Vivante GC7000 Nano Ultra Graphic Processing Unit (GPU-3D). supporting OpenGL ES2.0/1.1, Desktop OpenGL 2.1, OpenVG1.1, and GLSL shading language support.
Hardware Semaphore	SEMA42_0 and SEMA42_1	Multicore Peripherals and Resource Domain Control submodules	AD, RT	The Hardware Semaphore (SEMA42) module provides the hardware support needed in multicore systems for implementing semaphores and provide a simple mechanism to achieve "lock/unlock" operations via a single write access. SEMA42_0 is in the real-time domain. SEMA42_1 is in the application domain.
Input/Output Multiplexing Controller	IOMUXC0-1 & IOMUXC_DDR	System Control	AD, RT	The Input/Output Multiplexing Controller (IOMUXC) enables the chip to share one pad for multiple signals from different peripheral interfaces. This pad sharing mechanism is done by multiplexing the pad's input and output signals. The IOMUXC also controls the pads setting parameters and digital filter functions of the pad. In addition, the IOMUXC controls input multiplexing logic for input signals multiplexed at multiple locations. IOMUXC0 is in the real-time domain. IOMUXC1 and IOMUXC_DDR are in the application domain.
Internal Reference Clock 1kHz	IRC1K	Clock Sources and Control	SYS	The Internal Reference Clock 1kHz (IRC1K) module is an internal oscillator that can generate a reference clock of 1kHz. The IRC1K clock is enabled in all modes of operation, including all low power modes.
Joint Test Action Group Controller	JTAGC	Debug	RT	Joint Test Action Group Controller (JTAGC) provides the means to test chip functionality and connectivity while remaining transparent to system logic when not in test mode. Testing is performed via a boundary scan technique, as defined in the IEEE 1149.1-2001 standard.

Table continues on the next page...

Table 1. i.MX 7ULP modules list (continued)

Block Name	Block Mnemonic	Subsystem	Power Domain	Brief description
LCD Interface Controller	LCDIF	Multimedia	AD	The LCDIF is a general purpose display controller used to drive a wide range of display devices varying in size and capabilities. The LCDIF is used as a bridge between the DSI controller and the NIC0 crossbar.
Low-Leakage Wake-Up Unit	LLWU	System Control	DGO	The Low-Leakage Wake-Up Unit (LLWU) module allows user to select up to 32 external pin sources and up to 8 internal modules as a wakeup source from low leakage power modes.
Low Power Inter-Integrated Circuit	LPI2C0-7	Connectivity and Communications	AD, RT	The Low Power Inter-Integrated Circuit (LPI2C) module implements an efficient interface to an I2C bus as a master. The LPI2C can continue operating while the processor is in stop mode provided an appropriate peripheral clock is available. This module is designed for low CPU overhead with DMA offloading of FIFO register accesses. LPI2C0 - LPI2C3 are in the real-time domain. LPI2C4 - LPI2C7 are in the application domain.
Low Power Periodic Interrupt Timer	LPIT0-1	Timers	AD, RT	Low Power Periodic Interrupt Timer (LPIT) is a multichannel timer module that can generate independent pre-trigger and trigger outputs. These timer channels can operate individually or can be chained together. The pre-trigger and trigger outputs can be used to trigger other modules on the device. The LPIT can also operate in low power modes. LPIT0 is in the real-time domain. LPIT1 is in the application domain.
Low Power Serial Peripheral Interface	LPSPi0-3	Connectivity and Communications	AD, RT	The Low Power Serial Peripheral Interface (LPSPi) module implements an efficient interface to an SPI bus as a master and/or a slave. The LPSPi can continue operating while the processor is in stop mode if an appropriate peripheral clock is available. This module is designed for low CPU overhead with DMA offloading of FIFO register accesses. LPSPi0 and LPSPi1 are in the real-time domain. LPSPi2 and LPSPi3 are in the application domain.
Low-power Trusted Cryptography	LTC	Security	RT	Low-power Trusted Cryptography is an architecture that allows multiple cryptographic hardware accelerator engines to be instantiated and share

Table continues on the next page...

Table 1. i.MX 7ULP modules list (continued)

Block Name	Block Mnemonic	Subsystem	Power Domain	Brief description
				common registers. This version of LTC supports 128-bit AES. For details, see the <i>i.MX 7ULP Security Reference Manual</i> .
Low Power Universal Asynchronous Receiver/Transmitter	LPUART0-7	Connectivity and Communications	AD, RT	The Low Power Universal Asynchronous Receiver/Transmitter (LPUART) module provides asynchronous, serial communication capability with external devices. LPUART supports non-return-to-zero (NRZ) encoding format and IrDA-compatible infrared (low-speed) SIR format. The LPUART can continue operating while the processor is in stop mode if an appropriate peripheral clock is available. This module is designed for low CPU overhead with DMA offloading of FIFO register accesses. LPUART0 – LPUART3 are in the real-time domain. LPUART4 – LPUART7 are in the application domain.
Low Power Timer	LPTMR0-1	Timers	DGO	The Low Power Timer (LPTMR) module is a 16-bit timer which operates as real-time interrupt or pulse accumulator. This LPTMR module can remain functional when the chip is in low power modes, provided the reference clock to this timer is active.
Memory-Mapped Cryptographic Acceleration Unit	MMCAU	Security	RT	Memory-Mapped Cryptographic Acceleration Unit (MMCAU) is an optimized security accelerator that supports the cryptographic functions common in many security protocols. This includes DES, 3DES, AES, MD5, SHA-1, SHA-256 algorithms via simple C calls to optimized security functions.
Messaging Unit	MU	Multicore Peripherals and Resource Domain Control submodules	RT	Messaging Unit (MU) is a shared peripheral with a 32-bit IP bus interface and interrupt request signals to each host processor. The MU exposes a set of registers to each processor which facilitate inter-processor communication via 32-bit words, interrupts and flags. Interrupts may be independently masked by each processor to allow polled-mode operation.
MIPI Display Serial Interface Controller	DSI Controller	Multimedia	AD	The MIPI Display Serial Interface Controller (DSI Controller) is responsible for serializing display data from the GPU. Data can come from

Table continues on the next page...

Table 1. i.MX 7ULP modules list (continued)

Block Name	Block Mnemonic	Subsystem	Power Domain	Brief description
				either the GPU or the processor/DMA controller.
MIPI Display Serial Interface Physical Layer	DSI PHY	Multimedia	AD	The MIPI Display Serial Interface Physical Layer (DSI PHY) is a two-lane interface that supports up to 1 Gbps of data on each lane. DSI PHY includes a PLL which output clock is dedicated DSI uses.
Multicore System Mode Controller	MSMC	System Control	DGO	Multicore System Mode Controller (MSMC) is responsible for sequencing the system into and out of all low power Stop and Run modes. MSMC monitors events to trigger transitions between power modes, while controlling the power, clocks, and memories of the system to achieve the power consumption and functionality of that mode.
Multi Mode DDR Controller	MMDC	Memories and Memory Controllers	AD	The Multi Mode DDR Controller (MMDC) is a configurable DDR controller that provides interface to LPDDR2 or LPDDR3 memory. The MMDC consists of a core and PHY. The core is responsible for communication with the system through AXI interface, DDR commands generation, DDR command optimizations, and read/ write data path. The PHY performs timing adjustment using special calibration mechanisms to ensure data capture margin at the supported clock rate.
On-The-Fly AES Decryption	OTFAD	Security	RT	The On-The-Fly AES Decryption (OTFAD) module provides an advanced hardware implementation that minimizes any incremental cycles of latency introduced by the decryption in the overall external memory access time. The OTFAD engine also includes complete hardware support for a standard AES key unwrap mechanism to decrypt a key BLOB data instruction containing the parameters needed for up to 4 unique AES contexts.
Peripheral Clock Control	PCC0-3	Clock Sources and Control	AD, RT	The Peripheral Clock Control (PCC) module is responsible for clock selection, optional division and clock gating mode for peripherals in their respected power domain. PCC0 and PCC1 are in the real-time domain.

Table continues on the next page...

Table 1. i.MX 7ULP modules list (continued)

Block Name	Block Mnemonic	Subsystem	Power Domain	Brief description
				PCC2 and PCC3 are in the application domain.
Reset Mode Controller	RMC	System Control	DGO	Reset Mode Controller (RMC) implements reset modes and reset functions of the chip.
On-Chip One-Time-Programmable Controller	OCOTP_CTRL	System Control	RT	The On-Chip One-Time-Programmable Controller (OCOTP_CTRL) module provides an interface for reading, programming and/or overriding identification and control information stored in on-chip fuse elements. The module supports electrically-programmable poly fuses. The OCOTP_CTRL also provides a set of volatile software-accessible signals which can be used for software control of hardware elements, not requiring non-volatility.
Peripheral Trigger Multiplexing	TRGMUX0-1	System Control	AD, RT	Peripheral Trigger Multiplexing (TRGMUX) TRGMUX0 is in the real-time domain. TRGMUX1 is in the application domain.
Port Control	PCTL_A-F	System Control	AD, RT	The Port Control (PCTL) module provides control for GPIO interrupt function. GPIO interrupt can be configured independently for each pin in the 32-bit port. There is one instance of the PCTL module for each port. PCTL_A and PCTL_B are in the real-time domain. PCTL_C - PCTL_F are in the application domain.
Quad Serial Peripheral Interface	QSPI	Memories and Memory Controllers	RT	The Quad Serial Peripheral Interface (QSPI) module provides an interface to various types of serial flash memory. The QSPI interface allows one serial flash connection. It supports 1-bit, 4-bit and 8-bit SPI bus width.
Rapid General-Purpose Input and Output	RGPIO2P0-1	System Control	AD, RT	The Rapid General-Purpose Input and Output with 2 Ports (RGPIO2P) is similar to the RGPIO module, except it has an AHB-lite port, in addition to the IPS port, for faster access. RGPIO2P0 is in the real-time domain. RGPIO2P1 is in the application domain.
Read-only memory Controller	ROMCP0/1	Memories and Memory Controllers	AD, RT	A ROM controller and boot ROM are present in for both the A7 and M4 CPU cores. ROMCP0 and a 64 kB ROM are in the real-time domain. ROMCP1 and a 96 kB ROM are in the application domain.

Table continues on the next page...

Table 1. i.MX 7ULP modules list (continued)

Block Name	Block Mnemonic	Subsystem	Power Domain	Brief description
Real Time Clock Oscillator	RTC OSC	Clock Sources and Control	VBAT	The Real Time Clock Oscillator (RTC OSC) module provides the clock source for the Real-Time Clock module. The RTC OSC module, in conjunction with an external crystal, generates a 32.678 kHz reference clock for the RTC.
Single Wire Output	SWO	Debug	RT	Single Wire Output (SWO) is a trace data drain that acts as bridge between the on-chip trace data to a data stream that is captured by the Trace Port Analyzer. It is a TPIU-like device that supports a limited subset of the full TPIU functionality for a simple debug solution.
Secure JTAG Controller	SJC	Debug	RT	The Secure JTAG Controller (SJC) is an authenticated debug module that implements a challenge/response mechanism using a standard cryptographic algorithm. This allows post production silicon debug without compromising security requirements. The SJC is connected in parallel with the JTAGC module, but it is only used for authenticated debug.
Secure Non-Volatile Storage	SNVS	Security	VBAT	The Secure Non-Volatile Storage (SNVS) module is designed to safely hold security-related data such as cryptographic key, time counter, monotonic counter, and general purpose security information. A part of the SNVS module belongs to the VBAT domain that has its own dedicated power supply which is always on. This enables SNVS to keep this data valid and continue to increment the time counter when the power goes down in the rest of the SoC. SNVS includes the Real-Time Clock (RTC) module, which provides 64-bit monotonic counter with roll-over protection, 32-bit seconds counter with roll-over protection and 32-bit alarm.
Slow Internal Reference Clock	SIRC	Clock Sources and Control	SYS	The Slow Internal Reference Clock (SIRC) module is an internal oscillator that can generate a reference clock of 16 MHz. The SIRC output clock is used as a reference to the SCG module, and it is also used as a clock option to most on-chip modules.

Table continues on the next page...

Table 1. i.MX 7ULP modules list (continued)

Block Name	Block Mnemonic	Subsystem	Power Domain	Brief description
Synchronous Audio Interface	SAI0-1	Multimedia	RT	The Synchronous Audio Interface (SAI) module implements full-duplex serial interfaces with frame synchronization such as I2S, AC97, and CODEC/DSP interfaces.
System Clock Generation	SCG0-1	Clock Sources and Control	AD, RT	The System Clock Generation (SCG) module is responsible for clock generation and distribution across this device. Functions performed by the SCG include: clock reference selection, generation of clock used to derive processor, system, peripheral bus and external memory interface clocks; source selection for peripheral clocks; and, control of power saving clock gating mode. SCG0 is in the real-time domain. SCG1 is in the application domain.
System Integration Module	SIM	System Control	AD, RT	The System Integration Module (SIM) provides system control and chip configuration registers. The SIM includes the TSTMR module.
System Oscillator	SYS OSC	Clock Sources and Control	SYS	The System Oscillator (SYS OSC) module is a crystal oscillator. The SYS OSC, in conjunction with an external crystal or resonator, generates a reference clock for this device. It also optionally supports an external input clock provided to EXTAL signal directly.
Tightly-Coupled Memory	TCM	Memories and Memory Controllers	RT	Tightly Coupled Memory (TCM) RAM. This RAM is tightly integrated to the M4 processor. M4 accesses this memory with zero wait-state. There is a backdoor port that allows M4 DMA and other bus masters in the SoC to access this memory.
Timer/Pulse Width Modulation	LPTPM0-7	Timers	AD, RT	The Timer/Pulse Width Modulation Module (TPM) is a multichannel timer module that supports input capture, output compare, and the generation of PWM signals. The counter, compare and capture registers are clocked by an asynchronous clock that can remain enabled in low power modes. LPTPM0 – LPTPM3 are in the real-time domain. LPTPM4 – LPTPM7 are in the application domain.
TimeStamp Components	TimeStamp Components	Debug	RT	The timestamp components generate and distribute a consistent timestamp

Table continues on the next page...

Table 1. i.MX 7ULP modules list (continued)

Block Name	Block Mnemonic	Subsystem	Power Domain	Brief description
				value for multiple processors and other blocks in a SoC.
Timestamp timer	TSTMR	Timers	AD, RT	The TSTMR module is a free running incrementing counter that starts running after system reset de-assertion and can be read at any time by the software for determining the software ticks. The TSTMR is a 64-bit clock cycle counter. It runs off the 1 MHz clock and resets on every system reset. The counter only stops when the clock to the TSTMR is disabled.
Trace Funnel	FUNL	Debug	RT	The Trace Funnel (FUNL) is used when there is more than one trace source. The Trace Funnel combines multiple trace streams onto a single ATB bus. The Trace Funnel includes an arbiter that determines the priority of the ATB inputs.
Trace Port Interface Unit	TPIU	Debug	RT	Trace Port Interface Unit (TPIU) acts as a bridge between on-chip trace data, ID distinguishable, and a TPA. It receives ATB trace data and sends it off chip via ARM's standard trace interface. The TPIU includes ATB interface, APB interface, Formatter, Asynchronous FIFO, Register bank, Trace out serializer, and a pattern generator.
Trace Replicator	Replicator	Debug	RT	The Trace Replicator (Replicator) enables two trace sinks (TPIU and TMC) to be wired together and receive ATB trace data from the same trace source. It takes incoming data from a single source and replicates it to two master ports.
True Random Number Generator	TRNG	Security	RT	The True Random Number Generator (TRNG) module is to generate high quality, cryptographically secure, random data. The TRNG module is capable of generating its own entropy using an integrated ring oscillator. In addition, the module's NIST certifiable Pseudo-Random Number Generator (PRNG) provides accelerated processing of pseudo-random data.
ultra Secured Digital Host Controller	uSDHC0/1	Memories and Memory Controllers	AD	The ultra Secured Digital Host Controller (uSDHC) provides the interface between the host system and SD, SDIO or eMMC cards. The uSDHC acts as a bridge, passing host bus

Table continues on the next page...

Table 1. i.MX 7ULP modules list (continued)

Block Name	Block Mnemonic	Subsystem	Power Domain	Brief description
				transactions to the cards by sending commands and performing data accesses to/from the cards or devices. It handles SD, SDIO and eMMC protocol at transmission level.
Universal Serial Bus High-Speed Inter Chip Physical Layer	HSIC-PHY	Connectivity and Communications	AD	USB High-Speed Inter Chip Physical Layer (HSIC-PHY) is a complete digital IP designed to implement USB 2.0 HSIC connectivity interface.
Universal Serial Bus On-The-Go	USB-OTG	Connectivity and Communications	AD	The Universal System Bus On-The-Go (USB-OTG) module is a USB 2.0-compliant implementation. The registers and data structures of this USB controller are based on the Enhanced Host Controller Interface Specification for Universal Serial Bus (EHCI). This module can act as a host, a device or an On-The-Go negotiable host/device on the USB bus.
Universal Serial Bus Phase Locked Loop	USB PLL	Clock Sources and Control	AD	USB Phase Locked Loop (USB PLL) is embedded in the USB transceiver block. This PLL allows an exact 480 MHz to be generated from a supported reference clock of 24 MHz. The output of this PLL is primarily used for PLL operation. The USB PLL clock is also made available as a clock source for other peripherals in the SoC.
Universal Serial Bus Physical Layer	USB-PHY	Connectivity and Communications	AD	The Universal System Bus Physical Layer (USB-PHY) implements USB physical layer connecting to USB host/device systems at low-speed, full-speed, and high-speed. USB-PHY provides a standard UTMI interface for connection to the USB-OTG controller.
Video Input Unit	VIU	Multimedia	AD	The Video Input Unit (VIU) provides a parallel interface for digital video. The VIU accepts various types of digital video input on its parallel interface, decodes it and optionally performs processes such as down-scaling, horizontal up-scaling, brightness and contrast adjustment, pixel format conversion, deinterlacing and horizontal mirroring. The resultant video stream is then stored to system memory for subsequent post-processing and display.
Wakeup Unit	WKPU	System Control	AD	Wakeup Unit (WKPU) module is capable of interrupt detection and wake-

Table continues on the next page...

Table 1. i.MX 7ULP modules list (continued)

Block Name	Block Mnemonic	Subsystem	Power Domain	Brief description
				up of the Cortex-A processor when it is in low power mode.
Watchdog Timer	WDOG0-2	Timers	AD, RT	The Watchdog Timer (WDOG) module keeps a watch on the system functioning and resets it in case of its failure. Reasons for failure include run-away software code and the stoppage of the system clock that in a safety critical system can lead to serious consequences. In such cases, the WDOG brings the system into a safe state of operation. The WDOG monitors the operation of the system by expecting periodic communication from the software, generally known as servicing or refreshing the WDOG. If this periodic refreshing does not occur, the WDOG resets the system. WDOG0 is in the real-time domain. WDOG1 and WDOG2 are in the application domain.
XRDC Manager	MGR	Multicore Peripherals and Resource Domain Control submodules	RT	The XRDC Manager (MGR) submodule coordinates all programming model reads and writes.
XRDC Master Domain Assignment Controller	MDAC	Multicore Peripherals and Resource Domain Control submodules	AD, RT	The XRDC Master Domain Assignment Controller (MDAC) submodule handles resource assignments and generation of the domain identifiers.
XRDC Memory Region Controller	MRC	Multicore Peripherals and Resource Domain Control submodules	AD, RT	The XRDC Memory Region Controller (MRC) submodule implements the access controls for slave memories based on the pre-programmed region descriptor registers.
XRDC Peripheral Access Controller	PAC	Multicore Peripherals and Resource Domain Control submodules	AD, RT	The XRDC Peripheral Access Controller (PAC) implements the access controls for slave peripherals based on the pre-programmed domain access control registers.

2 Clocking

2.1 Introduction

This section details the clock sources, distribution and management within the i.MX 7ULP. These functions are under joint control of the System Clock Generation (SCG) modules, Peripheral Clock Control (PCC) modules, and Core Mode Controller (CMC) blocks.

NOTE

References in this chapter to “Core 0” or “Processor A” correspond to the Cortex M4 core. References in this chapter to “Core 1” or “Processor B” correspond to the Cortex A7 core.

The clocking scheme provides clear separation between M4 domain and A7 domain. Except for a few clock sources shared between two domains, such as the System Oscillator clock, the Slow IRC (SIRC), and the Fast IRC clock (FIRC), clock sources and clock management are separated and contained within each domain.

M4 clock management consists of SCG0, PCC0, PCC1, and CMC0 modules.

A7 clock management consists of SCG1, PCC2, PCC3, and CMC1 modules.

2.2 Clock distribution

The SCG modules generate and distribute clocks on the device. SCG functions include:

- clock reference selection
- generation of clock used to derive processor, system, peripheral bus and external memory interface clocks
- source selection for peripheral clocks
- control of power-saving clock-gating mode

PCC modules control clock selection, optional division and clock gating mode for peripherals.

NOTE

- To bypass system oscillator and directly apply clock from pin, SCG_SOSCCFG[EREFS] should be set to 0. The direct clock should be applied on the EXTAL pin.
- For using oscillator reference, SCG_SOSCCSR[SOSCEN] and SCG_SOSCCFG[EREFS] should both be set to 1.

2.3 External clock sources

In normal functional mode, this device operates off two primary external reference clocks: System oscillator clock (SOSC) and RTC oscillator clock (ROSC):

- System oscillator clock is a high frequency reference clock with a frequency in the range of 16 MHz to 32 MHz. This clock is used as a reference clock to the on-chip PLLs which generate all the required high frequency clocks.
- RTC oscillator clock is the 32.768 kHz constant frequency, real-time clock.

2.4 Oscillators

The system oscillator, in conjunction with an external crystal or resonator, generates a reference clock for the device. The system oscillator module supports 16-32 MHz crystals or resonators. It also provides the option for an external input clock to EXTAL signal directly.

The RTC oscillator is in the VBAT domain. The RTC oscillator module, in conjunction with an external crystal, generates a 32.768 kHz real-time reference clock for the RTC and will always be enabled and supplying clock to SRTC. This is the default clock source.

2.5 Internal clock sources

This device is capable of generating these internal reference clocks:

- The FIRC is the fast IRC clock with nominal frequency in the range from 48 to 60 MHz. In addition, the FIRC provides a clock selection option for peripherals.
- The SIRC is the slow IRC clock with nominal frequency of 16 MHz. The SIRC provides a clock selection option for peripherals.
- The IRC1K generates 1 kHz clock that is enabled in all modes of operation, including all low power modes.
- The RTC OSC has the capability to provide nominal 32 kHz (not recommended for accurate clock and normal operation) IRC in absence of the external OSC reference clock if the VBAT domain is enabled.

NOTE

The internal oscillator is automatically multiplexed in the clocking system when the system detects a loss of clock. The internal oscillator will provide clocks to the same on-

chip modules as the external 32 kHz oscillator. The internal oscillator is not precise relative to a crystal. While it will provide a clock to the system, it generally will not be precise enough for long-term time keeping. The internal oscillator is anticipated to be useful for quicker start-up times and tampering prevention, but should not be used as the exclusive source for the 32 kHz clocks. An external 32 kHz clock source must be used for production systems.

3 Application domain (implementing ARM Cortex-A7)

The application domain is built around an ARM Cortex-A7 processor optimized to run nominally at 500 MHz, supported by a 32 KB L1 instruction and data cache, a large L2 cache, and an LPDDR2/LPDDR3 memory interface. The Cortex-A7 processor is a high-performance low-power processor that implements the ARMv7-A architecture. It uses the generic interrupt controller (GIC), generic 64-bit OS timer, FPU and the ARM NEON SIMD engine. Additionally, all the optional debug features are included.

3.1 Memory system—application domain

3.1.1 Internal memory (application domain)

3.1.2 Multi Mode DDR Controller (MMDC)

The Multi Mode DDR Controller is a dedicated interface to LPDDR2/LPDDR3 SDRAM.

The i.MX 7ULP MMDC is compatible with the following JEDEC-compliant memory types:

- LPDDR2 SDRAM compliant to JESD209-2F LPDDR2 JEDEC standard released June, 2013
- LPDDR3 SDRAM compliant to JESD209-3C JEDEC standard released August, 2015

MMDC operation with the standards stated above is contingent upon the board DDR design adherence to the DDR design and layout requirements stated in the *Hardware Development Guide for the i.MX 7ULP Applications Processor (IMX7ULPHDG)*.

NOTE

For more information on MMDC, please refer to the following Engineering Bulletin: EB00913 - LPDDR2/LPDDR3 Parameter Optimizations for i.MX 7ULP.

The table below shows the supported LPDDR2/LPDDR3 configurations:

Table 2. i.MX 7ULP supported LPDDR2/LPDDR3 configurations

Parameter	LPDDR2	LPDDR3
Clock frequency	up to 271.5 MHz	
Bus width	x16/x32	
Channel	Single	
Chip select	Up to two	

3.1.3 eMMC

eMMC is a managed NAND device.

See [Ultra-high-speed SD/SDIO/MMC host interface \(uSDHC\) AC timing—application domain](#).

3.2 Peripherals—application domain

3.2.1 Graphics processor human machine interfaces

The i.MX 7ULP Application Domain implements the following graphics processor human machine interfaces:

- 3D graphics processing unit (GPU-3D)
- 2D graphics processing unit (GPU-2D)
- MIPI Display Serial Interface Controller (MIPI DSI)
- Video Interface Unit (VIU)

See the [i.MX 7ULP modules list](#) for more details.

3.2.2 Security—application domain

3.2.2.1 True Random Number Generator (TRNG)

The TRNG module is used to generate high quality, cryptographically secure, random data. The TRNG module is capable of generating its own entropy using an integrated ring oscillator. In addition, the module's Pseudo-Random Number Generator (PRNG) provides accelerated processing of pseudo-random data.

3.2.2.2 Real-Time Clock (RTC)

The RTC module provides 64-bit monotonic counter with roll-over protection, 32-bit seconds counter with roll-over protection and 32-bit alarm. This timer module is extremely low power that allows it to operate on a backup power supply when the main power supply is cut off. The RTC remains functional in all low power modes and can generate an interrupt to exit any low power mode.

3.2.2.3 High Assurance Boot (HAB)

The High Assurance Boot (HAB) component of the ROM protects against the potential threat of attackers modifying areas of code or data in programmable memory to make it behave in an incorrect manner. The HAB also prevents attempts to gain access to features which should not be available.

The integration of the HAB feature with the ROM code ensures that the chip does not enter an operational state if the existing hardware security blocks have detected a condition that may be a security threat or areas of memory deemed to be important have been modified. The HAB uses RSA digital signatures to enforce these policies.

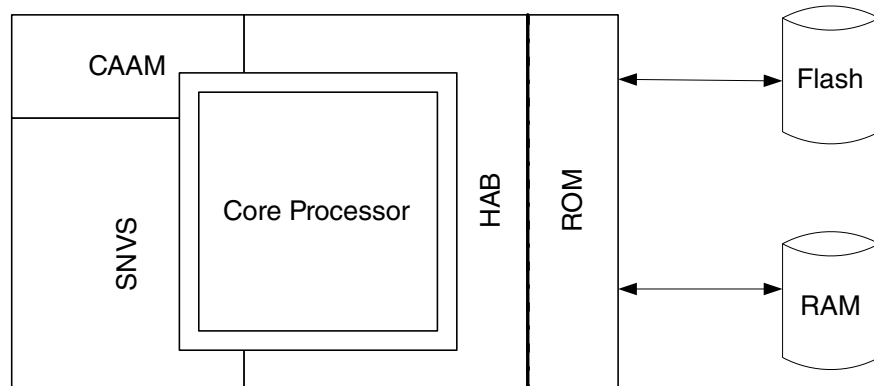

Figure 3. Secure Boot Components

NOTE

NXP provides a reference Code Signing Tool (CST) for key generation, certificate generation and code signing for use with the HAB library. The CST can be found by searching for "IMX_CST_TOOL" at <http://www.nxp.com>.

NOTE

For further details on making use of the secure boot feature using HAB, contact your local NXP representative.

3.2.3 Timers—application domain

The i.MX 7ULP Application Domain implements the following timers:

- Low Power Periodic Interrupt Timer (LPIT)
- Timer/PWM Module (LPTPM)
- Low Power Timer (LPTMR)
- External Watchdog Monitor (EWM)
- Time stamp timer module (TSTMR)
- WDOG (Watchdog Timer)

See [i.MX 7ULP modules list](#) for more details.

3.2.4 Connectivity and communications—applications domain

The i.MX 7ULP Application Domain implements the following connectivity and communications peripherals:

- Secure Digital (SD) Interface via the uSDHC
- Low Power Universal Asynchronous Receiver/Transmitter (LPUART)
- Low Power Inter-Integrated Circuit (LPI2C)
- Low Power Serial Peripheral Interface (LPSPI)
- Universal System Bus On-The-Go (USB-OTG)
- USB High-Speed Inter-Chip Physical Layer (HSIC-PHY)

See [i.MX 7ULP modules list](#) for more details.

4 Real-time domain (implementing ARM Cortex-M4)

The real-time domain is built around an ARM Cortex-M4 processor that contains a floating-point unit and is optimized for lowest possible leakage.

4.1 Memory system—real-time domain

4.1.1 Internal memory—real-time domain

The real-time domain contains 256 kB of SRAM organized in sub-blocks of 32 kB each. Each sub-block can be power-gated under software control to optimize power consumption.

4.1.2 QuadSPI flash

The Quad Serial Peripheral Interface (QSPI) module provides an interface to various types of serial flash memory. It allows one serial flash connection and supports 1-bit, 4-bit and 8-bit SPI bus width.

4.2 Peripherals—real-time domain

4.2.1 Analog—real-time domain

The i.MX 7ULP Real-Time Domain implements the following analog peripherals:

- 12-bit Analog to Digital Converter
- 12-bit Digital to Analog Converter
- Comparators

See [i.MX 7ULP modules list](#) for more details.

4.2.2 Connectivity and communications—real-time domain

The i.MX 7ULP Real-Time Domain implements the following connectivity and communications peripherals:

- Low Power Universal Asynchronous Receiver/Transmitter (LPUART)
- Low Power Inter-Integrated Circuit (LPI2C)
- Low Power Serial Peripheral Interface (LPSPI)
- Rapid General-Purpose Input and Output with 2 Ports (RGPIO2P)
- Flexible Input/Output (FlexIO)

See the [i.MX 7ULP modules list](#) for more details.

5 System control modules

5.1 JTAG—system control

Joint Test Action Group Controller (JTAGC) provides the means to test chip functionality and connectivity while remaining transparent to system logic when not in test mode. Testing is performed via a boundary scan technique, as defined in the IEEE 1149.1-2001 standard.

5.2 JTAG device identification register

The device identification register (JTAG ID) allows the revision number and part number to be read through the TAP. See the device identification register section of the *i.MX 7ULP Applications Processor Reference Manual* for details. This table shows the Part Identification Number (PIN) and the Part Revision Number (PRN) for each i.MX 7ULP silicon revision.

Table 3. JTAG device identification register information

Silicon Revision	Part Identification Number (PIN)	Part Revision Number (PRN)
A0	10'b0011100001	4'b0000
B0	10'b0011100001	4'b0001
B1	10'b0011100001	4'b0010
B2	10'b0011100001	4'b0011

The contents of the JTAD ID register are also mirrored in a SIM register called JTAG_ID_REG (address 0x410A_308C).

5.3 Oscillators and PLLs

5.3.1 System oscillator (SYS OSC)

The system oscillator (SYS OSC) is a crystal oscillator. The SYS OSC, in conjunction with an external crystal or resonator, generates a reference clock for this chip. It also provides the option for an external input clock to EXTAL signal directly.

5.3.2 Real-Time Clock Oscillator (RTC OSC)

The RTC OSC module provides the clock source for the Real-Time Clock module. The RTC OSC module, in conjunction with an external crystal, generates a 32.678 kHz reference clock for the RTC.

5.3.3 USB PLL

The USB PLL is embedded in the USB transceiver block. This PLL allows an exact 480 MHz to be generated from a supported reference clock of 24 MHz. The output of this PLL is primarily used for USB operations. The USB PLL clock is also made available as a clock source for other peripherals in the SoC.

5.3.4 Fixed Frequency PLL (Fixed-freq PLL)

In addition to the main clock output, this PLL also includes 4 Phase Fractional Dividers (PFDs) that can generate other clock frequencies. There is one instance of the Fixed-freq PLL (PLL0), which provides clocks for the M4 core, buses, and peripherals in the real-time domain.

5.3.5 Fractional-N PLL (FracN PLL)

The Fractional-N (Frac-N) PLL can generate an output clock 528 MHz from a supported reference clock. In addition to the main clock output, this PLL also includes up to four Phase Fractional Dividers (PFDs) that can generate other clock frequencies. This PLL also supports a tunable clock for audio applications.

5.4 Power Management

The i.MX 7ULP implements multiple options minimizing application power consumption:

- On-chip power management including regulators, drivers and switches for flexible power supplies, efficient power consumption and short wake up time
- Multiple power domains and ultra-low power modes allow flexible power saving
- Voltage and frequency scaling in dynamic operating modes
- Software-controlled clock gating for cores and peripherals
- Dynamic Process Monitor (DPM)

5.4.1 Digital PMC

The digital PMC module allows user software to control power modes and of the chip and to optimize power consumption for the level of functionality needed. There are two instances of digital PMC on this chip, one for each main power domain.

5.4.2 Analog power management controller (Analog PMC)

The Analog PMC consists of voltage/current references, core logic supply regulators, memory supply regulators, back and forward biasing regulators, monitors and power switches, etc. There are two Analog PMC subsystems, one associated with the M4 power domain and the other with the A7 power domain.

6 i.MX 7ULP LDO Bypass versus LDO-enabled modes

i.MX 7ULP has internal low-dropout (LDO) regulators to power certain sections of the core logic. In LDO Enabled mode, the internal LDO is used to regulate the core logic voltage under software control. In LDO Bypass mode, the internal LDO is disabled and the core logic supply voltage is provided externally.

The Real-time domain only supports LDO Enabled mode. The Application Domain supports either mode. The LDO modes require specific board-level connections. LDO Bypass vs. Enabled mode must be chosen prior to board design because the physical connection is different.

6.1 Real-time domain LDO Enabled mode

A 1.8 V nominal voltage supply is provided externally to the VDD_PMC18_DIG0 supply. The internal LDO output is routed to VDD_PMC11_DIG0_CAP. VDD_PMC11_DIG0_CAP must be routed back to VDD_DIG0 at the board-level with appropriate bypass capacitors to VSS. This connection has a maximum board routing impedance requirement. See parameter RDIG0 in [Table 5](#).

See the i.MX 7ULP Hardware Development Guide (IMX7ULPHDG) for details on the required bypass capacitors.

6.2 Application domain LDO Enabled mode

A 1.2 V nominal voltage supply is provided externally to the VDD_PMC12_DIG1 supply. The internal LDO output is routed to VDD_PMC11_DIG1_CAP. VDD_PMC11_DIG1_CAP must be routed back to VDD_DIG1 at the board-level with appropriate bypass capacitors to VSS. This connection has a maximum board routing impedance requirement. See parameter RDIG1 in [Table 5](#).

See the i.MX 7ULP Hardware Development Guide (IMX7ULPHDG) for details on the required bypass capacitors.

6.3 Application domain LDO BYPASS mode

The desired core logic supply voltage is provided externally to the VDD_PMC12_DIG1, VDD_PMC11_DIG1_CAP and VDD_DIG1 which are all tied together.

See the i.MX 7ULP Hardware Development Guide (IMX7ULPHDG) for details on the required bypass capacitors.

7 System specifications

7.1 Ratings

7.1.1 Thermal handling ratings

Symbol	Description	Min.	Max.	Unit	Notes
T _{STG}	Storage temperature	-55	150	°C	1
T _{SDR}	Solder temperature, lead-free	—	260	°C	2

1. Determined according to JEDEC Standard JESD22-A103, *High Temperature Storage Life*.
2. Determined according to IPC/JEDEC Standard J-STD-020, *Moisture/Reflow Sensitivity Classification for Nonhermetic Solid State Surface Mount Devices*.

7.1.2 Moisture handling ratings

Symbol	Description	Min.	Max.	Unit	Notes
MSL	Moisture sensitivity level	—	3	—	1

1. Determined according to IPC/JEDEC Standard J-STD-020, *Moisture/Reflow Sensitivity Classification for Nonhermetic Solid State Surface Mount Devices*.

7.1.3 ESD handling ratings

Symbol	Description	Min.	Max.	Unit	Notes
V _{HBM}	Electrostatic discharge voltage, human body model	-1000	+1000	V	1
V _{CDM}	Electrostatic discharge voltage, charged-device model	-250	+250	V	2

1. Determined according to JEDEC Standard JESD22-A114, *Electrostatic Discharge (ESD) Sensitivity Testing Human Body Model (HBM)*.
2. Determined according to JEDEC Standard JESD22-C101, *Field-Induced Charged-Device Model Test Method for Electrostatic-Discharge-Withstand Thresholds of Microelectronic Components*.

7.1.4 Absolute maximum ratings

CAUTION

Stresses beyond those listed under this table may cause permanent damage to the device. These are stress ratings only. Functional operation of the device at these or any other conditions beyond those indicated under “recommended operating conditions” is not implied. Exposure to absolute-maximum-rated conditions for extended periods may affect device reliability.

Table 4. Absolute maximum ratings

Parameter Description	Symbol	Min	Max	Unit
SNVS domain LDO supply input	VDD_VBAT42	-0.3	4.25	V
M4/A7 PMC and PMC IO supply input	VDD_PMC18	-0.3	1.98	V
1.8V IO supply reference and A7 supply reference input	VDD18_IOREF	-0.3	1.98	V
M4 domain LDO and internal memory LDO supply input	VDD_PMC18_DIG0	-0.3	1.98	V
M4 domain core and logic supply input	VDD_DIG0	-0.3	1.155	V
A7 domain core and logic supply inputs	VDD_PMC12_DIG1	-0.3	1.65	V
	VDD_PMC11_DIG1_CAP ¹	-0.3	1.155	V
	VDD_DIG1	-0.3	1.155	V
GPIO Port A supply input	VDD_PTA	-0.3	3.96	V
GPIO Port B supply input	VDD_PTB	-0.3	1.98	V
GPIO Port C supply input	VDD_PTC	-0.3	3.96	V
GPIO Port D supply input	VDD_PTD	-0.3	3.96	V
GPIO Port E supply input	VDD_PTE	-0.3	3.96	V
GPIO Port F supply input	VDD_PTF	-0.3	3.96	V
HSIC supply input	VDD_HSIC	-0.3	1.98	V
HSIC 1.8V pre-driver supply input	VDD18_HSIC	-0.3	1.98	V

Table continues on the next page...

Table 4. Absolute maximum ratings (continued)

Parameter Description	Symbol	Min	Max	Unit
DDR I/O supply input	VDD_DDR	-0.3	1.98	V
DDR 1.8V pre-driver supply input	VDD18_DDR	-0.3	1.98	V
MIPI DSI 1.1V supply input	VDD_DSI11	-0.3	1.155	V
MIPI DSI 1.8V supply input	VDD_DSI18	-0.3	1.98	V
USB PHY 3.3V supply input	VDD_USB33	-0.3	3.6	V
USB PHY 1.8V supply input	VDD_USB18	-0.3	1.98	V
USB0 VBUS detection	USB0_VBUS	-0.3	5.6	V
PLL analog supply input	VDD_PLL18	-0.3	1.98	V
ADC high reference supply input	VREFH_ANA18	-0.3	1.98	V
ADC analog and IO 1.8V supply input	VDD_ANA18	-0.3	1.98	V
ADC analog and IO 3.3V supply input	VDD_ANA33	-0.3	3.96	V

1. When used as an input in LDO Bypass Mode

7.1.5 Recommended operating conditions—system

NOTE

All supply inputs shown represent the voltage at the package ball.

Table 5. Recommended operating conditions

Symbol	Description	Conditions	Min	Typ	Max	Units
SNVS (Always On) Domain Supply Voltage Requirements						
VDD_VBAT42	SNVS domain LDO supply input	—	2.4	3.0	4.2	V
VDD_VBAT18_CAP	SNVS domain LDO output	—	—	1.8	—	V
Real Time Domain (M4 domain) Supply Voltage Requirements (LDO-Enabled Mode only supported)						
VDD_PMC18 ¹	M4/A7 PMC and PMC IO supply input	—	1.71	1.8	1.89	V
VDD18_IOREF ¹	1.8V IO supply reference and A7 supply reference input	—	1.71	1.8	1.89	V
VDD_PMC18_DIG0 ²	M4 domain LDO and internal memory LDO supply input	HSRUN mode not supported	1.14	1.2	1.89	V
		HSRUN mode supported	1.2	1.8	1.89	V
VDD_PMC11_DIG0_CAP ^{3,4}	M4 domain LDO supply output	—	0.65	—	1.1	V
Real Time Domain (M4 domain) PMC 0 Register Configuration Requirements						

Table continues on the next page...

Table 5. Recommended operating conditions (continued)

Symbol	Description	Conditions	Min	Typ	Max	Units
PMC0_HSRUN [COREREGVL]	PMC0 HSRUN mode LDO configuration requirements	HSRUN mode FBB=±0.3 V ⁵	—	101010b (1.05 V)	—	—
PMC0_RUN [COREREGVL]	PMC0 RUN mode LDO configuration requirements	RUN mode No bias	—	011100b (0.90 V)	—	—
PMC0_VLPR [COREREGVL]	PMC0 VLPR mode LDO configuration requirements	VLPR mode RBB=±/-1.0 V (optional) ⁶	—	011100b (0.90 V)	—	—
PMC0_STOP [COREREGVL]	PMC0 STOP mode LDO configuration requirements	STOP mode	—	011100b (0.90 V)	—	—
PMC0_VLPS [COREREGVL]	PMC0 VLPS mode LDO configuration requirements	VLPS mode RBB=±/-1.0 V (optional) ⁶	—	011100b (0.90 V)	—	—
PMC0_LLS [COREREGVL]	PMC0 LLS mode LDO configuration requirements	LLS mode RBB=±/-1.0 V (optional) ⁶	—	001101b (0.73V)	—	—
RDIG0	External board routing impedance from VDD_PMC11_DIG0_CAP to VDD_DIG0	—	—	—	50	mΩ
Application Domain (A7 domain) supply voltage requirements for LDO Bypass mode⁷						
VDD_PMC12_DIG1 VDD_PMC11_DIG1_CAP VDD_DIG1 VDD_DSI11 ⁸ .	A7 domain core and logic supply inputs MIPI DSI 1.1V supply input	HSRUN mode; FBB = ± 0.3V. ^{9, 10}	1.09	—	1.15	V
		RUN mode; No Bias	1.00	—	1.15	V
		VLPR mode	0.87	—	1.15	V
		WAIT mode	1.00	—	1.15	V
		STOP mode (CA7 halted and peripherals running at full rated speed)	1.00	—	1.15	V
		STOP mode (CA7 halted and peripherals running at VLPR speeds)	0.87	—	1.15	V
		VLPS mode ¹¹	0.73	—	1.15	V
		LLS Mode	0.73	—	1.15	V
		VLLS Mode ¹²	0.73	—	1.15	V
Application Domain (A7 domain) PMC1 register configuration requirements for LDO Enabled mode¹³						
VDD_PMC12_DIG1	A7 domain LDO and internal memory LDO supply input	—	1.14	1.2	1.32	V
VDD_PMC11_DIG1_CAP ¹⁴	A7 domain LDO supply output	—	0.65	—	1.15	V

Table continues on the next page...

Table 5. Recommended operating conditions (continued)

Symbol	Description	Conditions	Min	Typ	Max	Units
PMC1_RUN[LDOVL]	PMC1 RUN mode LDO configuration requirements	RUN mode; No Bias	—	100011b (0.95V)	—	V
PMC1_VLPR[LDOVL]	PMC1 VLPR mode LDO configuration requirements	VLPR mode	—	011110b (0.90V)	—	V
PMC1_STOP[LDOVL]	PMC1 STOP mode LDO configuration requirements	STOP mode (CA7 halted and peripherals running at full rated speed)	—	100011b (0.95V)	—	V
PMC1_STOP[LDOVL]	PMC1 STOP mode LDO configuration requirements	STOP mode (CA7 halted and peripherals running at VLPR speeds)	—	011110b (0.90V)	—	V
PMC1_VLPS[LDOVL]	PMC1 VLPS mode LDO configuration requirements	VLPS mode	—	011110b (0.90V)	—	V
PMC1_LLS[LDOVL]	PMC1 LLS mode LDO configuration requirements	LLS Mode	—	001011b (0.71V)	—	V
RDIG1	External board routing impedance from VDD_PMC11_DIG1_CAP to VDD_DIG1	—	—	—	50	mΩ
GPIO Supplies¹⁵						
VDD_PTA ^{16, 17}	GPIO Port A supply input	—	1.71	1.8 or 3.3	3.6	V
VDD_PTB ¹	GPIO Port B supply input	—	1.71	1.8	1.89	V
VDD_PTC	GPIO Port C supply input	—	1.71	1.8 or 3.3	3.6	V
VDD_PTD	GPIO Port D supply input	—	1.71	1.8 or 3.3	3.6	V
VDD_PTE	GPIO Port E supply input	—	1.71	1.8 or 3.3	3.6	V
VDD_PTF ¹⁸	GPIO Port F supply input	—	1.71	1.8 or 3.3	3.6	V
Peripheral/Interface Supplies						
VDD_HSIC	HSIC 1.2V supply input	—	1.14	1.2	1.32	V
VDD18_HSIC	HSIC 1.8V pre-driver supply input	—	1.71	1.8	1.89	V
VDD_DDR ¹⁹	DDR I/O supply input	—	1.14	1.2	1.26	V
VDD18_DDR	DDR 1.8V pre-driver supply input	—	1.71	1.8	1.89	V
VDD_DSI1 ⁸	MIPI DSI 1.1V supply input	—	0.8	1.1	1.155	V
VDD_DSI18	MIPI DSI 1.8V supply input	—	1.71	1.8	1.89	V
VDD_USB33	USB PHY 3.3V supply input	—	3.0	3.3	3.6	V
VDD_USB18	USB PHY 1.8V supply input	—	1.71	1.8	1.89	V
USB0_VBUS	USB0 VBUS detection	—	4.0 ²⁰ or 3.0 ²¹	5.0	5.5	V
Analog Supplies						
VDD_PLL18	PLL analog supply input	—	1.71	1.8	1.89	V

Table continues on the next page...

Table 5. Recommended operating conditions (continued)

Symbol	Description	Conditions	Min	Typ	Max	Units
VREFH_ANA18	ADC high reference supply input	—	1.71	1.8	1.89	V
VREFL_ANA	ADC low reference supply input	—	0	0	0	V
VDD_ANA18	ADC analog and IO 1.8V supply input	—	1.71	1.8	1.89	V
VDD_ANA33	ADC analog and IO 3.3V supply input	—	1.71	1.8 or 3.3	3.6	V

- VDD_PMC18, VDD18_IOREF and VDD_PT B are connected internally and, as such, must be driven from the same source.
- If VDD_PMC18_DIG0 is operated at 1.8 V, it should be tied to VDD_PMC18 at the board level.
- Note that the M4 LDO is always enabled, and the VDD_PMC11_DIG0_CAP is internally regulated. There is no LDO bypass option. VDD_PMC0_DIG0_CAP is connected to VDD_DIG0 at the board-level. The voltage observed at VDD_PMC18_DIG0_CAP differs from the from the programmed voltage on the internal LDO because the sense point for the LDO is on-chip.
- The table rows under the heading "Real Time Domain (M4 domain) PMC 0 Register Configuration Requirements" define the required voltage operating points for each operation mode. The register configurations shown must be used.
- FBB= \pm 0.3 V is the only supported FBB voltage level on the i.MX 7ULP. CM4 FBB voltage levels are configured in the PMC 0 Biasing Control register (BCTRL) fields FBBPLEVEL and FBBNLEVEL.
- RBB= \pm 1.0 V is the only supported RBB voltage level on the i.MX 7ULP. CM4 RBB voltage levels are configured in the PMC 0 Biasing Control register (BCTRL) fields RBBPLEVEL and RBBNLEVEL.
- Note that the A7 LDO can be operated in LDO-enabled mode or LDO-bypass mode. In LDO-bypass mode, the internal LDO is disabled and the voltage supply for the internal logic in the A7 domain is provided externally to VDD_PMC12_DIG1, VDD_PMC11_DIG1_CAP, and VDD_DIG1.
- If the MIPI DSI is used, VDD_DSI11 must be connected to VDD_DIG1 at board level. If MIPI DSI is not used, VDD_DSI11 can be connected to ground through a 10 K Ω resistor.
- CA7 domain HSRUN is limited to 8760 power-on hours over the lifetime of the product. The total power-on hours includes all CA7 power modes except VLLS mode and VBAT mode in which the CA7 domain is internally power-gated.
- FBB= \pm 0.3 V is the only supported FBB voltage level on the i.MX 7ULP. CA7 FBB voltage levels are configured in the PMC 1 Biasing Control register (BCTRL) fields FBBPLEVEL and FBBNLEVEL.
- To minimize power consumption in VLPS mode, configure PMC1 register bit SRAMCTRL[SRAM_STDY] to RETENTION mode.
- In VLLS mode, VDD_DIG1 is internally power gated to the application domain logic. VDD_DIG1 must remain powered if the following supplies are powered: VDD_USB18, VDD_USB33, VDD_DSI18 and VDD_DSI11. If the USB and DSI supplies are not used/powered, VDD_DIG1 can be turned off at the board level.
- Note that the A7 LDO can be operated in LDO-enabled mode or LDO-bypass mode. In LDO-enabled mode, the voltage supply to the internal logic in the A7 domain is regulated by the internal LDO.
- When using LDO-enabled mode, the voltage at the associated *_CAP ball differs from the programmed voltage because the sense point for the LDO is on-chip.
- To achieve minimum power consumption, VDD_PTA, VDD_PT B, VDD_PTC, VDD_PTE, and VDD_PTF must remain powered in all modes except BAT mode.
- VDD_PTA must be powered during a power-on reset (POR) for the SMC0 Mode register (MR) BOOTCFG field to properly latch the boot configuration from the PTA signals (GPIO Boot mode).
- VDD_ANA33 must be shorted to VDD_PTA at the board level.
- VDD_PTF must be powered during a power-on reset (POR) for the SMC1 Mode register (MR) BOOTCFG field to properly latch the boot configuration from the PTF signals (GPIO Boot mode). VDD_PTF must also remain powered during all A7 power modes except for BAT mode.
- VDD_DDR must remain powered while VDD18_DDR is powered.
- The 7ULP USB PHY provides two options for reporting VBUS valid back to the USB controller:
 - A programmable internal VBUS_VALID comparator (the default option), or
 - An alternate VBUS_VALID_3V detector that will report VBUS valid for voltages above 3 V

USBPHY_USB1_VBUS_DETECTn[VBUSVALID_SEL] selects which option is used. If the VBUS_VALID comparator is used, USBPHY_USB1_VBUS_DETECTn[VBUSVALID_THRESH] determines the threshold voltage for a valid VBUS. The programmable range is 4.0V to 4.4V (default).

21. The 7ULP USB PHY provides two options for reporting VBUS valid back to the USB controller:
- A programmable internal VBUS_VALID comparator (the default option), or
 - An alternate VBUS_VALID_3V detector that will report VBUS valid for voltages above 3 V.

USBPHY_USB1_VBUS_DETECTn[VBUSVALID_SEL] selects which option is used. If the VBUS_VALID_3V detector is used, the detector voltage is not programmable.

7.1.6 Estimated maximum supply currents

This table represents the estimated maximum current on the power supply rails and should be used for power supply selection. The data below is based on design simulation as well as measured data. Note that some of the data in the table is based on internal companion regulator limits and not actual use cases. Maximum currents are higher by far than the average power consumption of typical use cases.

Table 6. Estimated maximum supply currents

Power rail	Conditions	Maximum currents	Unit
VDD_VBAT42	4.2 V	23	μA
VDD_PLL18	1.8 V	8	mA
VDD18_IOREF + VDD_PMC18 + VDD_PTB ¹	1.8 V	Use Maximum IO equation ² + 10	mA
VDD18_DDR + VDD18_HSIC	1.8 V	15	mA
VDD_ANA18 + VREFH_ANA18	1.8 V	16	μA
VDD_DSI18	1.8 V	0.6	mA
VDD_USB18	1.8 V High speed mode	27	mA
VDD_PMC18_DIG0	1.8 V, CM4 200 MHz	60	mA
VDD_PMC12_DIG1 + VDD_DIG1 + VDD_DSI11	1.15 V CA7 LDO Bypass Mode CA7 500 MHz	350	mA
	1.15 V CA7 LDO Bypass Mode CA7 720 MHz	504	mA
VDD_PMC12_DIG1	1.2 V CA7 LDO Enabled Mode CA7 500 MHz	350	mA
	1.2 V CA7 LDO Enabled Mode CA7 720 MHz	504	mA

Table continues on the next page...

Table 6. Estimated maximum supply currents (continued)

Power rail	Conditions	Maximum currents	Unit
VDD_PTA	1.8 V or 3.3 V	Use Maximum IO equation ²	mA
VDD_PTC	1.8 V or 3.3 V	Use Maximum IO equation ²	mA
VDD_PTD	1.8 V or 3.3 V	Use Maximum IO equation ²	mA
VDD_PTE	1.8 V or 3.3 V	Use Maximum IO equation ²	mA
VDD_PTF	1.8 V or 3.3 V	Use Maximum IO equation ²	mA
VDD_DDR	1.2 V	Use Maximum IO equation ²	mA
VDD_HSIC	1.2 V	Use Maximum IO equation ²	mA
VDD_ANA33	3.3 V	3	μA
VDD_USB33	3.3 V Full speed mode	28	mA

- VDD_PMC18, VDD18_IOREF and VDD_PTB are connected internally and, as such, must be driven from the same source.
- General equation for estimated, maximum power consumption of an I/O power supply: $I_{\max} = N \times C \times V \times (0.5 \times F)$

Where:

N = Number of I/O pins supplied by the power line

C = Equivalent external capacitive load

V = I/O voltage

(0.5 × F) = Data change rate

In this equation, I_{\max} is in amps, C in farads, V in volts, and F in hertz.

NOTE

For additional power information, see the application note, AN12573: i.MX 7ULP Power Consumption Measurement.

7.2 System clocks

7.2.1 Clock modules

7.2.1.1 Fast IRC (FIRC) specifications

Table 7. FIRC specifications with 48 MHz internal reference frequency

Symbol	Description	Min.	Typ.	Max.	Unit	Notes
f_{irc48m}	Internal reference frequency	—	48	—	MHz	
$\Delta f_{irc48m_ol_lv}$	Open loop total deviation of IRC48M frequency	-1.5	—	1.5	% f_{irc48m}	

Table continues on the next page...

Table 7. FIRC specifications with 48 MHz internal reference frequency (continued)

Symbol	Description	Min.	Typ.	Max.	Unit	Notes
J_{cyc_irc48m}	Period Jitter (RMS)	—	35	150	ps	
$t_{irc48mst}$	Startup time	—	2	3	μ s	1

1. FIRC startup time is defined as the time between clock enablement and clock availability for system use.

Table 8. FIRC specifications with 60 MHz internal reference frequency

Symbol	Description	Min.	Typ.	Max.	Unit	Notes
f_{irc60m}	Internal reference frequency	—	60	—	MHz	
$\Delta f_{irc60m_ol_lv}$	Open loop total deviation of IRC60M frequency	-1.5	—	1.5	$\%f_{irc60m}$	
J_{cyc_irc60m}	Period Jitter (RMS)	—	35	150	ps	
$t_{irc60mst}$	Startup time	—	2	3	μ s	1

1. FIRC startup time is defined as the time between clock enablement and clock availability for system use.

7.2.1.2 Slow IRC (SIRC) specifications

Table 9. Slow IRC (SIRC) specifications

Symbol	Description	Min	Typ	Max	Unit
f_{irc16m}	Internal reference frequency	15.52	16	16.48	MHz
$\Delta f_{irc16m_ol_lv}$	Open loop total deviation of IRC16M frequency at low voltage (VDD=1.71V-1.89V) over temperature	-3.8%		3.8%	$\%f_{irc16m_ol_lv}$

7.2.1.3 Oscillator electrical specifications

7.2.1.3.1 Oscillator DC electrical specifications

Table 10. Oscillator DC electrical specifications

Symbol	Description	Min.	Typ.	Max.	Unit	Notes
C_x	EXTAL load capacitance	—	—	—		1
C_y	XTAL load capacitance	—	—	—		1
R_F	Feedback resistor — low-power mode (HGO=0)	—	—	—	M Ω	1, 2
	Feedback resistor — high-gain mode (HGO=1)	—	1	—	M Ω	
R_S	Series resistor — low-power mode (HGO=0)	—	0	—	Ω	
	Series resistor — high-gain mode (HGO=1)	—	0	—	Ω	

Table continues on the next page...

System specifications

Table 10. Oscillator DC electrical specifications (continued)

Symbol	Description	Min.	Typ.	Max.	Unit	Notes
V_{pp}^3	Peak-to-peak amplitude of oscillation (oscillator mode) — high-frequency, low-power mode (HGO=0)	—	0.8	—	V	
	Peak-to-peak amplitude of oscillation (oscillator mode) — high-frequency, high-gain mode (HGO=1)	0.75 x VDD_PMC18	0.8 x VDD_PMC18	—	V	

1. See crystal or resonator manufacturer's recommendation
2. When low power mode is selected, R_F is integrated and must not be attached externally.
3. The EXTAL and XTAL pins should only be connected to required oscillator components and must not be connected to any other devices.

7.2.1.3.2 System oscillator frequency specifications

Table 11. System oscillator frequency specifications

Symbol	Description	Min.	Typ.	Max.	Unit	Notes
f_{osc_lo}	Oscillator crystal or resonator frequency — low-frequency mode (SCG_C2[RANGE]=00)	4	—	32	MHz	
t_{dc_extal}	Input clock duty cycle (external clock mode)	40	50	60	%	

7.2.1.4 32 kHz oscillator electrical specifications

7.2.1.4.1 32 kHz oscillator DC electrical specifications

Table 12. 32kHz oscillator DC electrical specifications

Symbol	Description	Min.	Typ.	Max.	Unit
R_F	Internal feedback resistor	—	100	—	$M\Omega$
C_{para}	Parasitical capacitance of EXTAL32 and XTAL32	—	1.5	2.0	pF
V_{pp}^1	Peak-to-peak amplitude of oscillation	—	0.6	—	V

1. When a crystal is being used with the 32 kHz oscillator, the EXTAL32 and XTAL32 pins should only be connected to required oscillator components and must not be connected to any other devices.

7.2.1.4.2 32 kHz oscillator frequency specifications

Table 13. 32 kHz oscillator frequency specifications

Symbol	Description	Min.	Typ.	Max.	Unit	Notes
f_{osc_lo}	Oscillator crystal	—	32.768	—	kHz	
t_{start}	Crystal start-up time	—	500	—	ms	1

Table continues on the next page...

Table 13. 32 kHz oscillator frequency specifications (continued)

Symbol	Description	Min.	Typ.	Max.	Unit	Notes
V _{ec_extal32}	Externally provided input clock amplitude	700	—	VDD_VBAT18_CAP	mV	2, 3

1. Proper PC board layout procedures must be followed to achieve specifications.
2. This specification is for an externally supplied clock driven to EXTAL32 and does not apply to any other clock input. The oscillator remains enabled and XTAL32 must be left unconnected.
3. The parameter specified is a peak-to-peak value and V_{IH} and V_{IL} specifications do not apply. The voltage of the applied clock must be within the range of V_{SS} to VDD_VBAT18_CAP.

7.2.2 Core, platform, and system bus clock frequency limitations

The clock ratio restrictions among the core, platform and IP bus clocks are listed as follows:

- A7 core clock frequency is higher than A7 platform clock frequency.
- Clock ratio must be integers between A7 fast platform (NIC0) and A7 slow platform (NIC1).

NOTE

Use A7 SPLL for core clock and A7 APLL for DDR/NIC clocks.

- Clock ratio must be integers between A7 slow platform and A7 system IP bus.
- Clock ratio must be integers between M4 core/platform and M4 system IP bus.
- M4 slow clock must be slower and an integer division of M4 system IP bus.
- A7 Slow platform (NIC1) clock frequency should be higher than A7 System IP bus clock (NIC1_BUS clock).

The following tables show examples of various allowable clock frequencies for the cores, platforms, system bus, and DDR in different operating modes.

NOTE

The frequencies stated in these tables are typical configuration and maximum frequencies in a particular mode. However, since there are multiple clock dividers, different clock ratios can be achieved.

Table 14. Maximum A7 system clock frequencies¹

Configuration	A7 Core (MHz)	NIC0 (MHz) ²	GPU-3D/ GPU-2D (MHz)	DDR (MHz) ²	NIC1 (MHz)	A7 System IP Bus (MHz)	eMMC
RUN	500	380.16	400	271.5	190	95	HS200 mode

Table continues on the next page...

Table 14. Maximum A7 system clock frequencies¹ (continued)

Configuration	A7 Core (MHz)	NIC0 (MHz) ²	GPU-3D/ GPU-2D (MHz)	DDR (MHz) ²	NIC1 (MHz)	A7 System IP Bus (MHz)	eMMC
HSRUN	650	400	400 (GPU-2D)/ 650 (GPU-3D)	271.5	200	100	HS400 mode
VLPR	48	48	Not operational	Not operational (DDR in self-refresh mode)	48	24	Only 24 MHz compliant cards

1. The maximum operating frequency of a given clock must also observe the clock ratio restrictions described in this section
2. NIC0 and DDR are derived from the same clock.

NOTE

DGO peripherals on the M4 core use the `cm4.divslow_clk`, configured by `SCG_xCCR[DIVSLOW]` in all the modes, with the maximum frequency of 25 MHz.

Table 15. Maximum M4 system clock frequencies¹

Configuration	M4 Core/ Platform (MHz)	Platform (MHz)	M4 System IP Bus (MHz)	Slow clock (MHz)
RUN	120	120	60	20
HSRUN	200	200	100	25
VLPR	48	48	24	24

1. The maximum operating frequency of a given clock must also observe the clock ratio restrictions described in this section

7.2.3 Peripheral clock frequencies

The following table lists peripheral clock frequencies and the indication of platform and IP bus clocks. Some peripherals have a local clock generator that can further divide the clock, as required, for the desired serial rate.

Table 16. Peripheral clock frequencies

Module	A7 Fast Platform Clk	A7 Slow Platform Clk	A7 System IP Bus Clk	M4 Platform Clk	M4 System IP Bus Clk	Peripheral Clock (MHz)	Notes
AIPS-Lite	--	--	--	Yes	Yes	--	

Table continues on the next page...

Table 16. Peripheral clock frequencies (continued)

Module	A7 Fast Platform Clk	A7 Slow Platform Clk	A7 System IP Bus Clk	M4 Platform Clk	M4 System IP Bus Clk	Peripheral Clock (MHz)	Notes
AHB-PBridge	--	Yes	Yes	--	--	--	
AXBS	--	--	--	Yes	Yes	--	
NIC0	Yes	--	--	--	--		
NIC1	--	Yes	--	--	--	--	
AXI RAMC0	Yes	--	--	--	--	--	
AXI RAMC1	--	Yes	--	--	--	--	
AHB RAMC	--	--	--	Yes	--	--	
A7 ROMC	--	Yes	Yes	--	--	--	
M4 ROMC	--	--	--	Yes	Yes	--	
MMDC	Yes	--	Yes	--	--	400 200	
FlexBus	--	Yes	Yes	--	--	66.7 ¹	
QSPI	--	--	--	Yes	Yes	200, 100 320, 160, 80 108	DTR w/ DQS DTR w/o DQS STR
DMA1	--	Yes	Yes	--	--	--	
DMA0	--	--	--	Yes	Yes	--	
GPU-3D	Yes	Yes	--	--	--	800, 400 400, 200	
GPU-2D	--	Yes	--	--	--	800, 400 400, 200	
LPUART0-3	--	--	--	--	Yes	60	
LPUART4-7	--	--	Yes	--	--	60	
LPSPi0-1	--	--	--	--	Yes	60	
LPSPi2-3	--	--	Yes	--	--	100	
LPI2C0-3	--	--	--	--	Yes	60	
LPI2C4-7	--	--	Yes	--	--	60	
USB Controllers	--	Yes	Yes	--	--	60	Exact
USB PHY	--	--	Yes	--	--	480	Exact
USB HSIC	--	--	Yes	--	--	480	Exact
uSDHC	--	Yes	Yes	--	--	50 52 104 200	Support internal clock divider

Table continues on the next page...

Table 16. Peripheral clock frequencies (continued)

Module	A7 Fast Platform Clk	A7 Slow Platform Clk	A7 System IP Bus Clk	M4 Platform Clk	M4 System IP Bus Clk	Peripheral Clock (MHz)	Notes
RGPIO2P0	--	--	--	--	Yes	--	
RGPIO2P1	--	--	Yes	--	--	--	
FlexIO0	--	--	--	--	Yes	80	
FlexIO1	--	--	Yes	--	--	80	
LPIT0	--	--	--	--	Yes	60	
LPIT1	--	--	Yes	--	--	60	
TPM0-3	--	--	--	--	Yes	60	
TPM4-7	--	--	Yes	--	--	60	
LPTMR	--	--	--	--	Yes	30	
EWM	--	--	--	--	Yes	--	
DSI	--	Yes	Yes	--	--	500	
LCDIF	--	Yes	Yes	--	--	--	
VIU	--	Yes	Yes	--	--	66.7 ²	
SAI0-1	--	--	--	--	Yes	50	
CAAM ³	--	Yes	Yes	--	--	--	
SNVS	--	--	--	--	Yes	32.678 (kHz)	Exact for real-time clock
CRC	--	--	--	--	Yes	--	
TRNG	--	--	--	--	Yes	--	
LTC ³	--	--	--	--	Yes	--	
JTAG	--	--	--	--	Yes	--	
XRDC	--	--	--	--	Yes	--	
SEM42	--	--	--	--	Yes	--	
MU	--	--	Yes	--	Yes	--	
WDOG0	--	--	--	--	Yes	--	
WDOG1	--	--	Yes	--	--	--	
WDOG2 (Secure WDOG)	--	--	Yes	--	--	--	
ADC0-1	--	--	--	--	Yes	25	
DAC	--	--	--	--	Yes	--	
CMP0-1	--	--	--	--	Yes	--	
TPIU/SWO	--	--	--	--	--	100	

1. Flexbus clock frequency is generated using SCG1_NICCCR[NIC1_DIVEXT] and SCG1_NICCSR[NIC1_DIVEXT] fields through the CLKOUT pin
2. This is the value of pix_clk and not the ipg_clk
3. See i.MX 7ULP Security Reference Manual for complete chapter

7.2.4 PLL PFD output

All PLLs on i.MX 7ULP either have VCO base frequency of 480 MHz or 528 MHz. The following tables show all the possible combination of PFD output supported for 24 MHz input clock.

PFD Output = $18/N \times F_{VCO}$ where N = 12 to 35.

Table 17. PLL PFD output frequencies 1

PLL VCO (MHz)	FRAC (N)	PFD Output (MHz)
480	12	720
480	13	664
480	14	617.142
480	15	576
480	16	540
480	17	508.235
480	18	480
480	19	454.736
480	20	432
480	21	411.428
480	22	392.727
480	23	375.652
480	24	254.117
480	25	345.6
480	26	332.307
480	27	320
480	28	308.571
480	29	297.931
480	30	288
480	31	278.709
480	32	270
480	33	261.818
480	34	254.117
480	35	246.857

1. This table indicates the maximum frequency achievable by different PFD configurations; typical frequencies will limit the PFD Frac values to be programmed

System specifications

PLL VCO (MHz)	FRAC (N)	PFD Output (MHz)
528	12	792
528	13	731.07
528	14	678.8
528	15	633.6
528	16	594
528	17	559.0588235
528	18	528
528	19	500.2105263
528	20	475.2
528	21	452.5714286
528	22	432
528	23	413.217
528	24	396
528	25	380.16
528	26	365.538
528	27	352
528	28	339.428
528	29	327.724
528	30	316.8
528	31	306.580
528	32	297
528	33	288
528	34	279.529
528	35	271.5

7.2.5 Audio tunable clock

For audio applications where the data stream is coming from a remote source, the device has to locally tune a clock signal to match the remote system clock. The Auxiliary PLL, which provides the clock for master audio, has synchronization logic to support on-the-fly configuration changes. This allows the device to generate a tunable clock for audio stream. The clock from one of the Auxiliary PLLs (PLL1) can be divided by the post-dividers in analog and also the dividers in SCG module. The divided tunable clock generated should meet the following requirement:

- Output center frequency of 12.288 MHz or 11.2896 MHz
- Tunable range of ± 1000 ppm
- Tunable resolution of 1 ppm

- Settling time of < 100 μ sec
- RMS TIE jitter (long-term jitter) < 100 psec
- Frequency update must be smooth with no glitches

7.3 Power sequencing—system

7.3.1 Power-on sequencing

The power-on sequencing requirements for the device are described in this section. VDD_VBAT42 must be powered and stable before all other supplies begin to ramp up.

The real-time domain supplies must be powered and stable before RESET0_B is deasserted. The real-time domain supplies listed below may be powered on in any order except for those indicating specific sequencing requirements.

- VDD_PMC18_DIG0 and VDD_PMC18 must be powered on together, or VDD_PMC18 must be powered on first followed by VDD_PMC18_DIG0
- VDD_PLL_18
- VDD_PTA
- VDD_PT B
- VDD18_IOREF
- VREFH_ANA18
- VREFL_ANA
- VDD_ANA18
- VDD_ANA33

The application domain supplies must be powered on and stable before the A7 core exits reset. The M4 core controls the release of the A7 from reset. The application domain supplies listed below may be powered on in any order except for those indicating specific sequencing requirements.

- VDD_PMC12_DIG1
- VDD_PMC11_DIG1_CAP (if using A7 LDO bypass mode)
- VDD_DIG1 (if using A7 LDO bypass mode)
- VDD_PTC
- VDD_PTD and VDD18_IOREF must be powered together, or VDD18_IOREF powered on first followed by VDD_PTD
- VDD_PTE

System specifications

- VDD_PTF
- VDD18_DDR
- DDR_VREF0, DDR_VREF1
- VDD_HSIC
- VDD18_HSIC
- VDD_DSI11
- VDD_DSI18
- VDD_USB33
- VDD_USB18
- VDD_DDR must be powered and stable before the A7 core exits reset.

The application domain supplies must not be powered when the real-time supplies are off.

In A7 LDO bypass mode, VDD_USB18 and VDD_DSI18 should not be powered when VDD_DIG1 is not powered, or additional leakage current will occur.

See [Table 18](#) for interfaces and power supplies that are not used.

7.3.2 Power-off sequencing

The i.MX 7ULP has no power-off sequencing requirements.

7.4 Requirements for unused interfaces

This table shows the required connections for unused interfaces.

Table 18. Required connections for unused interfaces

Module	Supply Name	Description	Recommendations if module is unused
ADC	VREFH_ANA18	High Reference supply for ADC	10 k Ω resistor to ground
	VREFL_ANA	Low Reference supply for ADC	10 k Ω resistor to ground
	VDD_ANA18	1.8 V supply for ADC Analog and IO segment	10 k Ω resistor to ground
	VDD_ANA33	3.3 V supply for ADC Analog and IO segment	10 k Ω resistor to ground
DAC	DAC0_OUT	DAC0 output	Leave unconnected
	DAC1_OUT	DAC1 output	Leave unconnected
MIPI DSI	VDD_DSI11	MIPI 1.1 V supply	10 k Ω resistor to ground
	VDD_DSI18	MIPI 1.8 V supply	10 k Ω resistor to ground

Table continues on the next page...

Table 18. Required connections for unused interfaces (continued)

Module	Supply Name	Description	Recommendations if module is unused
	DSI_CLK_N	MIPI Negative Clock Signal	Leave unconnected
	DSI_CLK_P	MIPI Positive Clock Signal	Leave unconnected
	DSI_DATA0_N	MIPI Negative Data0 Signal	Leave unconnected
	DSI_DATA0_P	MIPI Positive Data0 Signal	Leave unconnected
	DSI_DATA1_N	MIPI Negative Data1 Signal	Leave unconnected
	DSI_DATA1_P	MIPI Positive Data1 Signal	Leave unconnected
Port D Signals	VDD_PTD	Port D supply	10 kΩ resistor to ground
USB0	VDD_USB33	USB0 PHY 3.3 V supply	10 kΩ resistor to ground
	VDD_USB18	USB0 PHY 1.8 V supply	10 kΩ resistor to ground
	USB0_DM	USB D- Analog Data Signal on the USB Bus	Leave unconnected
	USB0_DP	USB D+ Analog Data Signal on the USB Bus	Leave unconnected
	USB0_VBUS_DETECT	USB0 VBUS Detect	10 kΩ resistor to ground

7.5 Electrical Characteristics and Thermal Specifications

7.5.1 AC electrical characteristics

Unless otherwise specified, propagation delays are measured from the 50% to the 50% point, and rise and fall times are measured at the 20% and 80% points, as shown in the following figure.

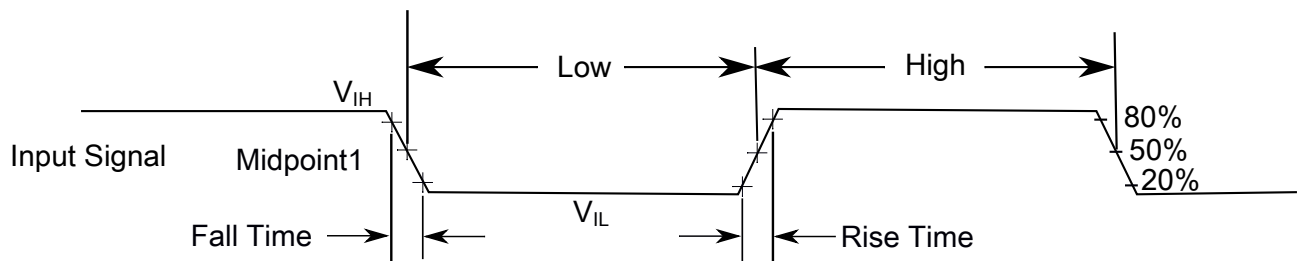

The midpoint is $V_{IL} + (V_{IH} - V_{IL}) / 2$

Figure 4. Input signal measurement reference

All digital I/O switching characteristics, unless otherwise specified, assume all output signals:

- have $C_L=30\text{pF}$ loads,

System specifications

- are slew rate disabled, and
- are normal drive strength

7.5.2 Nonswitching electrical characteristics

7.5.2.1 GPIO DC Electrical Requirements

Table 19. GPIO DC Electrical Requirements

Symbol	Parameter	Condition	Min	Typ	Max	Unit
V_{tol}	Fail-safe I/O tolerance when pad supply is off (PTA, PTB, PTC, PTE and PTF)	VDD_PT _x =0			3.6	V
I_{tol}	I/O current when pad supply is off	VDD_PT _x =0 or floating			1	μA
V_{ih}	Input High	VDD_PT _x = 1.72 - 1.95 V	0.7*VDD_PT _x			V
		VDD_PT _x = 2.7 - 3.6 V	0.7*VDD_PT _x			V
V_{il}	Input Low	VDD_PT _x = 1.72 - 1.95 V	-0.3		0.3*VDD_PT _x	V
		VDD_PT _x = 2.7 - 3.6 V	-0.3		0.7	V
DeltaV	Input Hysteresis	VDD_PT _x = 1.72 - 1.95 V	0.15			V
		VDD_PT _x = 2.7 - 3.6 V	0.15			V
I_{ih}	High level input current	VDD_PT _x = 1.72 - 1.95 V	-1	0.5	1	μA
		VDD_PT _x = 2.7 - 3.6 V	-1	0.5	1	μA
I_{il}	Low level input current	VDD_PT _x = 1.72 - 1.95 V Vin = VSS	-1		1	μA
		VDD_PT _x = 2.7 - 3.6 V Vin = VSS	-1		1	μA
V_{oh} (Low Drive)	High Level Output Voltage	VDD_PT _x = 1.72 - 1.95 V I _{oh} = -2.9mA	0.8*VDD_PT _x			V
		VDD_PT _x = 2.7 - 3.6 V I _{oh} = -4mA	0.8*VDD_PT _x			V
V_{oh} (High Drive)	High Level Output Voltage	VDD_PT _x = 1.72 - 1.95 V I _{oh} = -5.8mA	0.8*VDD_PT _x			V
		VDD_PT _x = 2.7 - 3.6 V I _{oh} = -8mA	0.8*VDD_PT _x			V
V_{ol} (Low Drive)	Low Level Output Voltage	VDD_PT _x = 1.72 - 1.95 V I _{oh} = 2.9mA			0.2*VDD_PT _x	V
		VDD_PT _x = 2.7 - 3.6 V I _{oh} = 4mA			0.2*VDD_PT _x	V

Table continues on the next page...

Table 19. GPIO DC Electrical Requirements (continued)

Symbol	Parameter	Condition	Min	Typ	Max	Unit
V _{ol} (High Drive)	Low Level Output Voltage	VDD_PT _x = 1.72 - 1.95 V I _{oh} = 5.8mA			0.2*VDD_PT _x	V
		VDD_PT _x = 2.7 - 3.6 V I _{oh} = 8mA			0.2*VDD_PT _x	V
I _{oz}	Output Hi-Z current		-5		5	μA

7.5.2.1.1 GPIO Pull-up and Pull-Down Resistance

Table 20. Failsafe GPIO (FSGPIO) pull-up and pull-down resistance (PTA, PTB, PTC, PTE and PTF)

Symbol	Parameter	Min	Max	Unit
R Pull up	Pull-up resistance	25	50	kΩ
R Pull down	Pulldown resistance	25	50	kΩ

Table 21. Standard GPIO (STGPIO) pull-up and pull-down resistance (PTD)

Symbol	Parameter	Min	Max	Unit
R Pull up	Pull-up resistance, high voltage range (2.7 V – 3.6 V)	10	100	kΩ
	Pull-up resistance, Low voltage range (1.71 V – 1.89 V)	20	50	kΩ
R Pull down	Pull-down resistance, High voltage range (2.7 V – 3.6 V)	10	100	kΩ
	Pull-down resistance, Low voltage range (1.71 V – 1.89 V)	20	50	kΩ

7.5.2.2 Capacitance attributes

See the device IBIS model for pin capacitance values for the package being used.

7.5.3 Switching electrical characteristics

7.5.3.1 General switching timing specifications

These general purpose specifications apply to all signals configured for GPIO, UART, and timer functions.

Table 22. General switching timing specifications

Symbol	Parameter	Min	Typ	Max	Unit	Notes
tw_GPIO_sync	GPIO pin interrupt pulse width (Digital Filter disabled) — Synchronous path	1.5	—	—	Bus clock cycles	1
tw_RESET_async	External RESET and NMI pin interrupt pulse width — Asynchronous path	30	—	—	ns	2
tw_GPIO_async	GPIO pin interrupt pulse width — Asynchronous path	30	—	—	ns	2

1. The greater synchronous and asynchronous timing must be met.
2. This is the shortest pulse that is guaranteed to be recognized.

7.5.3.2 GPIO rise and fall times

Table 23. FSGPIO rise and fall time (PTA, PTB, PTC, PTE, and PTF)

Symbol	Parameter	Condition			Min	Typ	Max	Unit	Notes
trf	transition time	Continuous Voltage Range Normal VDD_PTx = 2.7–3.6 V	CL = 25pF	Slow Slew Rate		8.3		ns	1
				Standard Slew Rate		3.4		ns	
trf	transition time	Continuous Voltage Range Derated VDD_PTx = 1.98–2.7V	CL = 25pF	Slow Slew Rate		7.3		ns	
				Standard Slew Rate		0.9		ns	
trf	transition time	Continuous Voltage Range Derated VDD_PTx = 1.71–1.98V	CL = 25pF	Slow Slew Rate		5.4		ns	
				Standard Slew Rate		0.8		ns	
trf	transition time	High Voltage Range VDD_PTx = 3–3.6 V	CL = 25pF	Slow Slew Rate		8.3		ns	
				Standard Slew Rate		3.4		ns	
trf	transition time	Low Voltage Range VDD_PTx = 1.71–1.98 V	CL = 25pF	Slow Slew Rate		5.5		ns	
				Standard Slew Rate		0.7		ns	

1. VDD1P8 = 1.8V

Table 24. STGPIO rise and fall time (PTD)

Symbol	Parameter	Condition			Min	Typ	Max	Unit	Notes
trf	transition time	High Voltage Range VDD_PTx = 3–3.6 Volts	CL = 25pF	Slow Slew Rate		12.0		ns	1
				Standard Slew Rate		4.1		ns	

Table continues on the next page...

Table 24. STGPIO rise and fall time (PTD) (continued)

Symbol	Parameter	Condition			Min	Typ	Max	Unit	Notes
trf	transition time	Low Voltage Range VDD_PT _x = 1.71–1.98 Volts	CL = 25pF	Slow Slew Rate		7.4		ns	
				Standard Slew Rate		0.8		ns	

1. VDD1P8 = 1.8V

7.5.3.3 GPIO output buffer maximum frequency

Table 25. GPIO output buffer maximum frequency

Symbol	Parameter	Condition	Min	Max	Unit
Mfreq (low drive low slew)	Maximum Frequency	VDD_PT _x = 1.65 - 1.95 V, CL = 5pf	—	120	MHz
		VDD_PT _x = 1.65 - 1.95 V, CL = 10pf	—	100	MHz
		VDD_PT _x = 1.65 - 1.95 V, CL = 40pf	—	50	MHz
		VDD_PT _x = 2.7 - 3.6 V, CL = 5pf	—	115	MHz
		VDD_PT _x = 2.7 - 3.6 V, CL = 10pf	—	95	MHz
		VDD_PT _x = 2.7 - 3.6 V, CL = 40pf	—	40	MHz
Mfreq (low drive high slew)	Maximum Frequency	VDD_PT _x = 1.65 - 1.95 V, CL = 5pf	—	185	MHz
		VDD_PT _x = 1.65 - 1.95 V, CL = 10pf	—	145	MHz
		VDD_PT _x = 1.65 - 1.95 V, CL = 40pf	—	50	MHz
		VDD_PT _x = 2.7 - 3.6 V, CL = 5pf	—	170	MHz
		VDD_PT _x = 2.7 - 3.6 V, CL = 10pf	—	130	MHz
		VDD_PT _x = 2.7 - 3.6 V, CL = 40pf	—	40	MHz
Mfreq (high drive low slew)	Maximum Frequency	VDD_PT _x = 1.65 - 1.95 V, CL = 5pf	—	140	MHz
		VDD_PT _x = 1.65 - 1.95 V, CL = 10pf	—	125	MHz
		VDD_PT _x = 1.65 - 1.95 V, CL = 40pf	—	85	MHz
		VDD_PT _x = 2.7 - 3.6 V, CL = 5pf	—	130	MHz
		VDD_PT _x = 2.7 - 3.6 V, CL = 10pf	—	115	MHz
		VDD_PT _x = 2.7 - 3.6 V, CL = 40pf	—	70	MHz
Mfreq (high drive high slew)	Maximum Frequency	VDD_PT _x = 1.65 - 1.95 V, CL = 5pf	—	235	MHz
		VDD_PT _x = 1.65 - 1.95 V, CL = 10pf	—	200	MHz
		VDD_PT _x = 1.65 - 1.95 V, CL = 40pf	—	100	MHz
		VDD_PT _x = 2.7 - 3.6 V, CL = 5pf	—	215	MHz
		VDD_PT _x = 2.7 - 3.6 V, CL = 10pf	—	185	MHz
		VDD_PT _x = 2.7 - 3.6 V, CL = 40pf	—	80	MHz

7.5.4 Debug and trace modules

7.5.4.1 JTAG timing specifications

Table 26. JTAG timing specifications

Symbol	Parameter	Min	Max	Min— VLPR mode	Max— VLPR mode	Unit
J1	TCLK frequency of operation					
	• Boundary Scan	0	10	0	10	MHz
	• JTAG	0	25	0	10	MHz
J2	TCLK cycle period	1000/J1	—	1000/J1	—	ns
J3	TCLK clock pulse width					
	• Boundary Scan	50	—	50	—	ns
	• JTAG	20	—	20	—	ns
J4	TCLK rise and fall times	—	3	—	3	ns
J5	Boundary scan input data setup time to TCLK rise	20	—	20	—	ns
J6	Boundary scan input data hold time after TCLK rise	5	—	5	—	ns
J7	TCLK low to boundary scan output data valid	—	28	—	28	ns
J8	TCLK low to boundary scan output high-Z	—	25	—	25	ns
J9	TMS, TDI input data setup time to TCLK rise	10.5	—	19	—	ns
J10	TMS, TDI input data hold time after TCLK rise	2.5	—	2	—	ns
J11	TCLK low to TDO data valid	—	19	—	19	ns
J12	TCLK low to TDO high-Z	2	—	2	—	ns
J13	$\overline{\text{TRST}}$ assert time	100	—	100	—	ns
J14	$\overline{\text{TRST}}$ setup time (negation) to TCLK high	8	—	8	—	ns

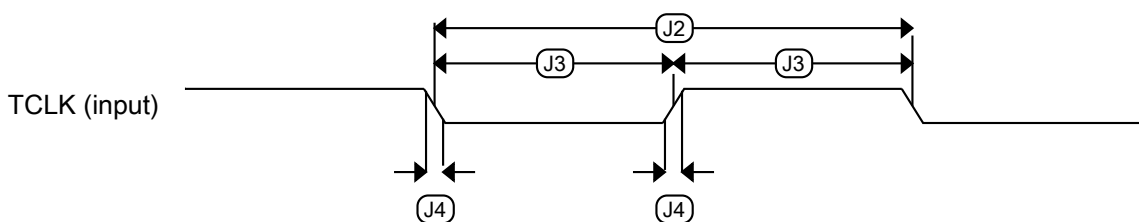

Figure 5. Test clock input timing

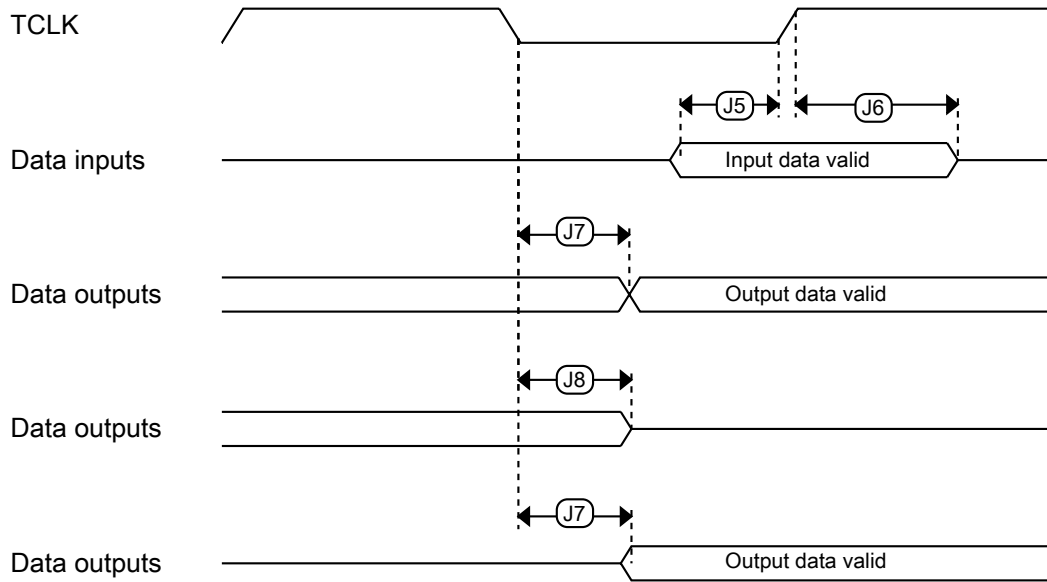

Figure 6. Boundary scan (JTAG) timing

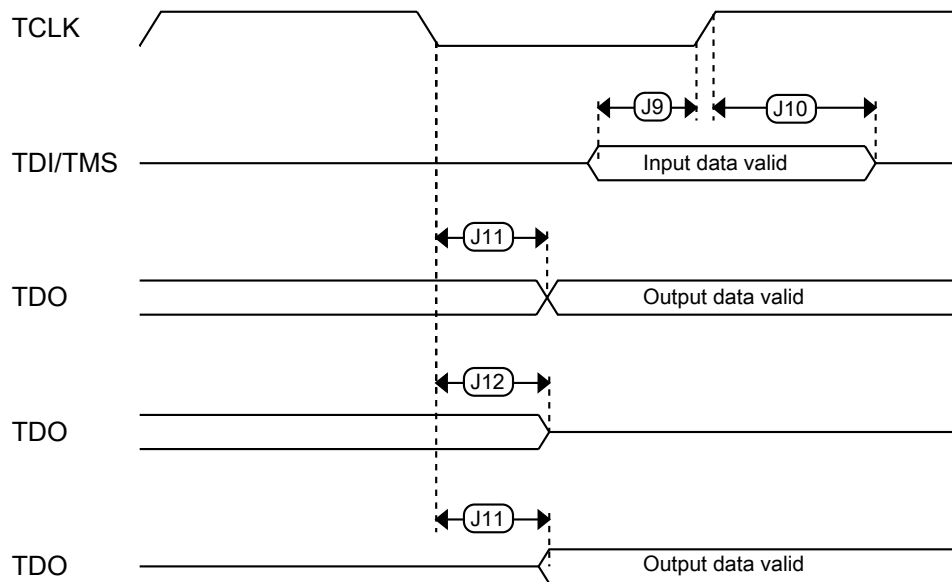

Figure 7. Test Access Port timing

System specifications

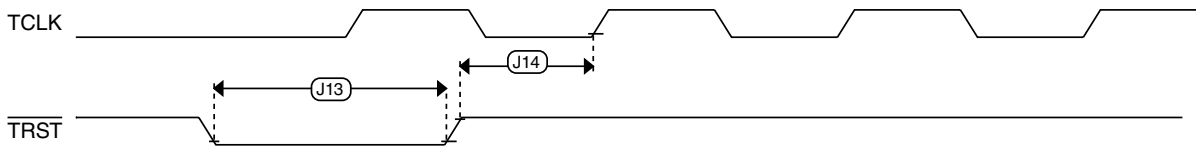

Figure 8. $\overline{\text{TRST}}$ timing

7.5.4.2 Serial Wire Debug (SWD) timing specifications

Table 27. SWD timing specifications

Symbol	Description	Min	Max	Min— VLPR mode	Max— VLPR mode	Unit
J1	SWD_CLK frequency of operation	0	25	0	10	MHz
J2	SWD_CLK cycle period	1000/J1	—	1000/J1	—	ns
J3	SWD_CLK clock pulse width	20	—	20	—	ns
J4	SWD_CLK rise and fall times	—	3	—	3	ns
J9	SWD_DIO input data setup time to SWD_CLK rise	10	—	19	—	ns
J10	SWD_DIO input data hold time after SWD_CLK rise	0	—	0	—	ns
J11	SWD_CLK high to SWD_DIO data valid	—	37	—	37	ns
J12	SWD_CLK high to SWD_DIO high-Z	2	—	2	—	ns

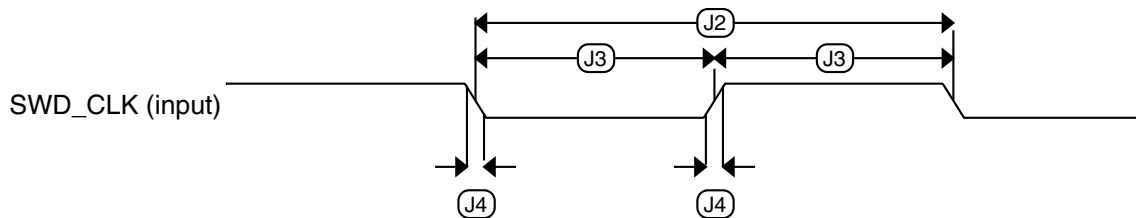

Figure 9. SWD clock input timing

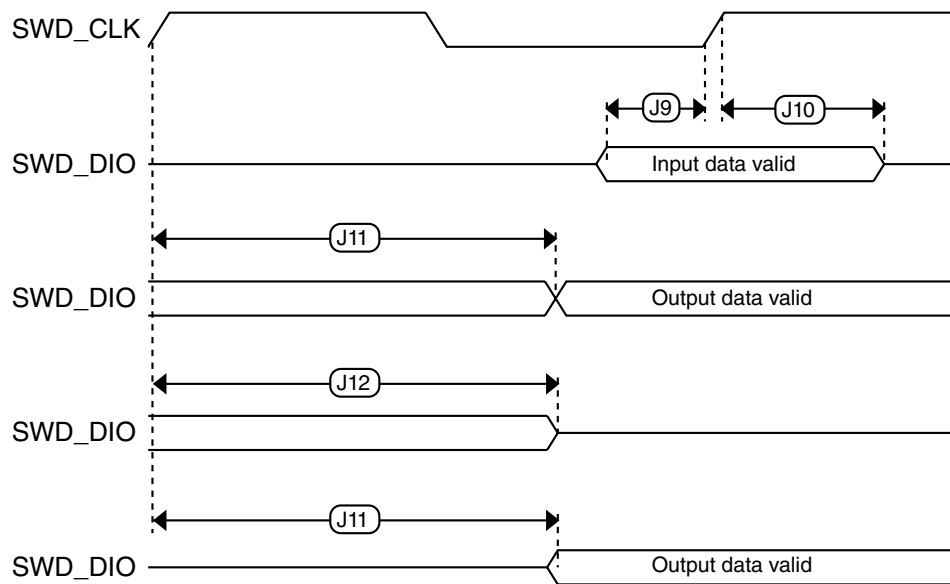

Figure 10. SWD data timing

7.5.5 Thermal specifications

7.5.5.1 Thermal operating requirements

Table 28. Thermal operating requirements

Symbol	Parameter	Min.	Typ	Max.	Unit
T_J	Die junction temperature—Industrial	-40	–	105	°C

7.5.5.2 Thermal attributes

NOTE

Per JEDEC JESD51-2, the intent of thermal resistance measurements is solely for a thermal performance comparison of one package to another in a standardized environment. This methodology is not meant to and does not predict the performance of a package in an application-specific environment.

Table 29. Thermal resistance data

Rating	Test Conditions	Symbol	14x14 mm (VK) Package Value	Unit	Notes
Junction to Ambient Natural Convection	Single-layer board (1S)	R θ JA	49.5	°C/W	1,2
Junction to Ambient Natural Convection	Four-layer board (2s2p)	R θ JA	30.7	°C/W	1,2,3
Junction to Ambient (@ 200 ft/min)	Single-layer board (1S)	R θ JMA	38.6	°C/W	1,3
Junction to Ambient (@ 200 ft/min)	Four-layer board (2s2p)	R θ JMA	26.0	°C/W	1,3
Junction to Board	–	R θ JB	15.6	°C/W	4
Junction to Case	–	R θ JC	11.7	°C/W	5
Junction to Package Top	Natural Convection	Ψ JT	0.4	°C/W	6
Junction to Package Bottom	Natural Convection	Ψ JB	10.1	°C/W	7

1. Junction temperature is a function of die size, on-chip power dissipation, package thermal resistance, mounting site (board) temperature, ambient temperature, air flow, power dissipation of the other components on the board, and board thermal resistance.
2. Per SEMI G38-87 and JEDEC JESD51-2 with the single layer board horizontal.
3. Per JEDEC JESD51-6 with the board horizontal.
4. Thermal resistance between the die and the printed circuit board per JEDEC JESD51-8. Board temperature is measured on the top surface of the board near the package.
5. Thermal resistance between the die and the case top surface as measured by the cold plate method (MIL SPEC-883).
6. Thermal characterization parameter indicating the temperature difference between package top and the junction temperature per JEDEC JESD51-2. When Greek letters are not available, the thermal characterization parameter is written as Ψ JT.
7. Thermal resistance between the die and the central solder balls on the bottom of the package based on simulation.

8 Specifications—application domain

8.1 Peripheral operating requirements and behaviors

8.1.1 DDR timing—application domain

See [Multi Mode DDR Controller \(MMDC\)](#).

8.1.2 Ultra-high-speed SD/SDIO/MMC host interface (uSDHC) AC timing—application domain

This section describes the electrical information of the uSDHC, which includes support for eMMC and SD (Secure Digital) interfaces.

eMMC is designed to be compliant with the eMMC specification 5.0 and supports the following modes:

- Backward Compatibility mode (MMC)
- High Speed mode
- HS200
- HS400

The SD (Secure Digital) interface is designed to be compliant with the SD 3.0 specification and supports the following operating modes:

- SDR12
- SDR25
- SDR50
- SDR104
- DDR50

8.1.2.1 SD/eMMC4.3 (single data rate) AC timing

The following figure shows the AC timing of SD/eMMC4.3, and the table lists the SD/eMMC4.3 timing characteristics.

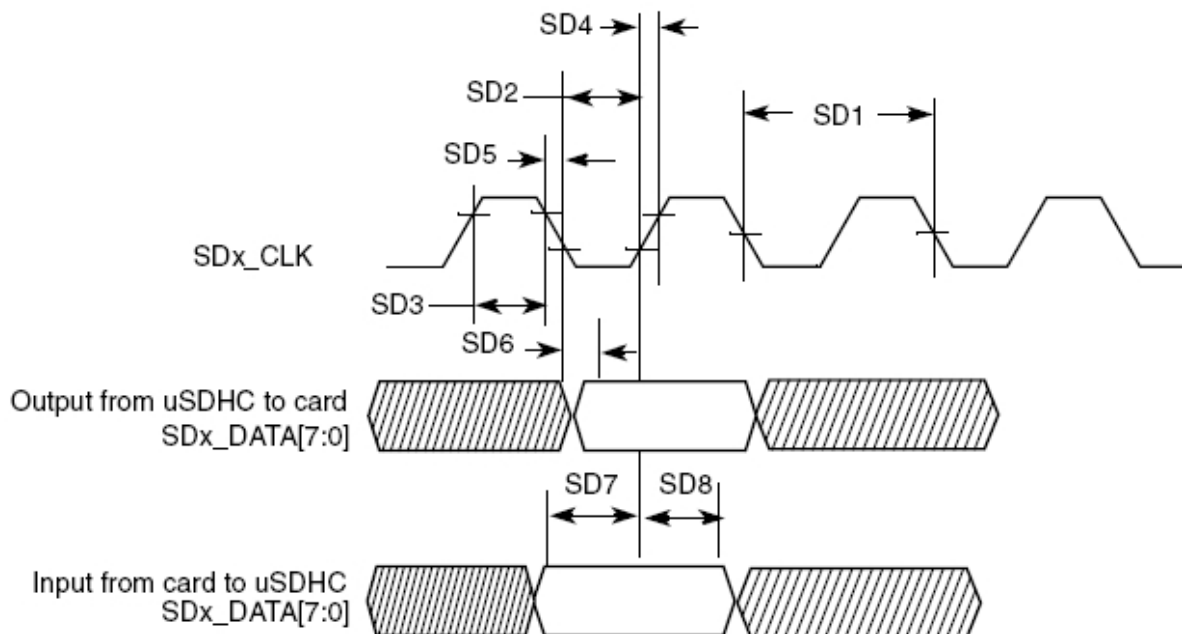

Figure 11. SD/eMMC4.3 AC timing

Table 30. SD/eMMC4.3 AC parameters

ID	Parameter	Symbols	Min	Max	Unit
Card Input Clock					
SD1	Clock Frequency (Low Speed)	f_{PP}^1	0	400	kHz
	Clock Frequency (SD/SDIO Full Speed/High Speed)	f_{PP}^2	0	25/50	MHz
	Clock Frequency (MMC Full Speed/High Speed)	f_{PP}^3	0	20/52	MHz
	Clock Frequency (Identification Mode)	f_{OD}	100	400	kHz
SD2	Clock Low Time	t_{WL}	7	—	ns
SD3	Clock High Time	t_{WH}	7	—	ns
SD4	Clock Rise Time	t_{TLH}	—	3	ns
SD5	Clock Fall Time	t_{THL}	—	3	ns
uSDHC Output/Card Inputs SD_CMD, SDx_DATAx (Reference to CLK)					
SD6	uSDHC Output Delay	t_{OD}	-3.3	3.6	ns
uSDHC Input/Card Outputs SD_CMD, SDx_DATAx (Reference to CLK)					
SD7	uSDHC Input Setup Time	t_{ISU}	7.5	—	ns
SD8	uSDHC Input Hold Time ⁴	t_{IH}	1.0	—	ns

1. In Low-Speed mode, card clock must be lower than 400 kHz, voltage ranges from 2.7 to 3.6 V.
2. In Normal (Full) -Speed mode for SD/SDIO card, clock frequency can be any value between 0–25 MHz. In High-speed mode, clock frequency can be any value between 0–50 MHz.
3. In Normal (Full) -Speed mode for MMC card, clock frequency can be any value between 0–20 MHz. In High-speed mode, clock frequency can be any value between 0–52 MHz.

4. To satisfy hold timing, the delay difference between clock input and cmd/data input must not exceed 2 ns.

8.1.2.2 eMMC4.4/4.41 (dual data rate) AC timing

The following figure shows the timing of eMMC4.4/4.41, and the table lists the eMMC4.4/4.41 timing characteristics. Note that only DATA is sampled on both edges of the clock (not applicable to CMD).

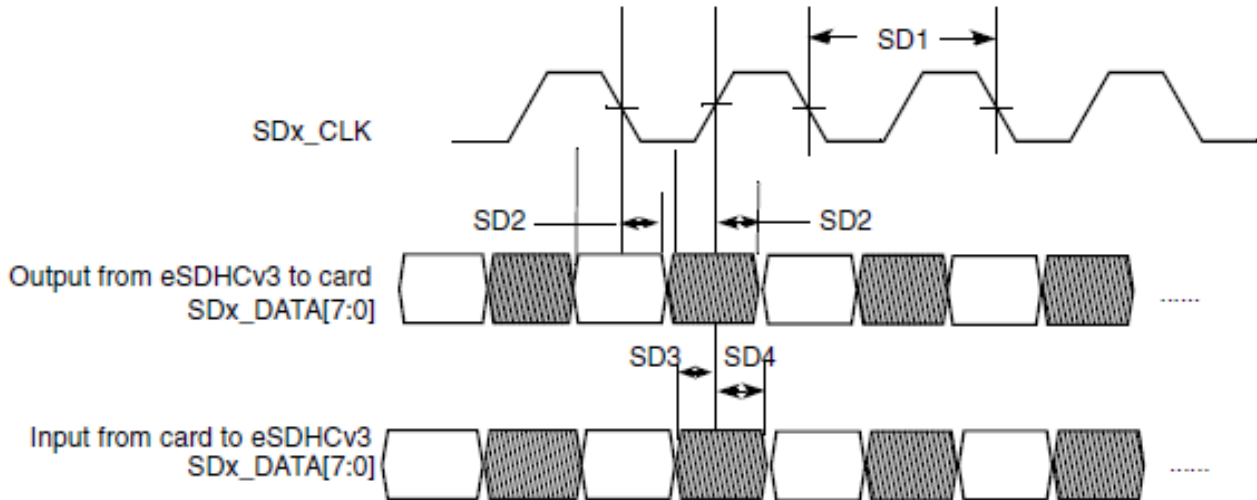

Figure 12. eMMC4.4/4.41 timing

Table 31. eMMC4.4/4.41 interface timing specifications

ID	Parameter	Symbols	Min	Max	Unit
Card Input Clock					
SD1	Clock Frequency (eMMC4.4/4.41 DDR)	f_{PP}	0	52	MHz
SD1	Clock Frequency (SD3.0 DDR)	f_{PP}	0	50	MHz
uSDHC Output / Card Inputs SD_CMD, SDx_DATAx (Reference to CLK)					
SD2	uSDHC Output Delay	t_{OD}	-3.3	3.6	ns
uSDHC Input / Card Outputs SD_CMD, SDx_DATAx (Reference to CLK)					
SD3	uSDHC Input Setup Time	t_{ISU}	7.3	—	ns
SD4	uSDHC Input Hold Time	t_{IH}	1.0	—	ns

8.1.2.3 HS200 mode timing

The following figure depicts the timing of HS200 mode, and the subsequent table lists the HS200 timing characteristics.

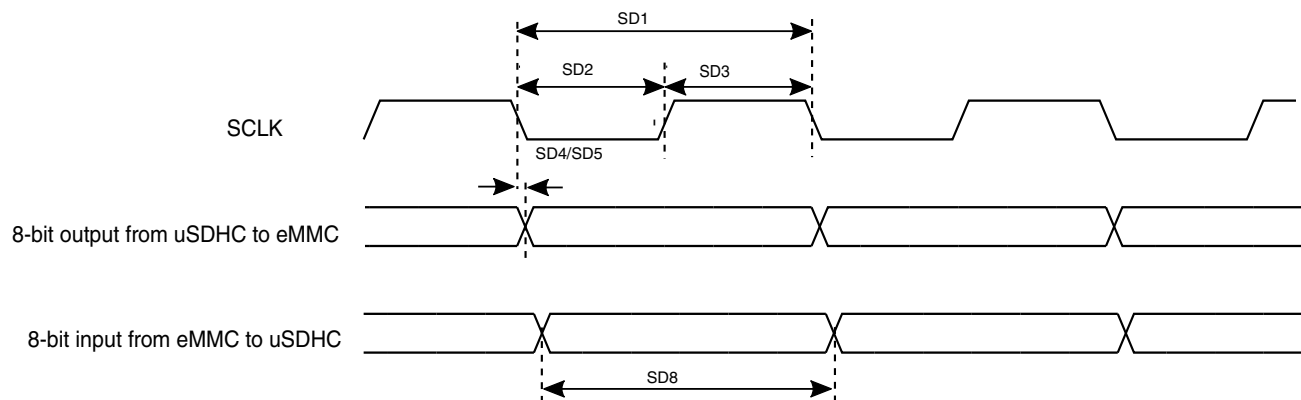

Figure 13. HS200 timing

Table 32. HS200 interface timing specifications

ID	Parameter	Symbols	Min.	Max.	Unit
Card Input clock					
SD1	Clock Frequency Period	t_{CLK}	5.0	—	ns
SD2	Clock Low Time	t_{CL}	$0.46 \times t_{CLK}$	$0.54 \times t_{CLK}$	ns
SD3	Clock High Time	t_{CH}	$0.46 \times t_{CLK}$	$0.54 \times t_{CLK}$	ns
uSDHC Output/Card Inputs SD_CMD, SDx_DATAx in HS200 (Reference to CLK)¹					
SD5	uSDHC Output Delay	t_{OD}	-1.6	0.74	ns
uSDHC Input/Card Outputs SD_CMD, SDx_DATAx in HS200 (Reference to CLK)					
SD8	Card Output Data Window	t_{ODW}	$0.5 \times t_{CLK}$	—	ns

1. HS200 is for 8 bits while SDR104 is for 4 bits

8.1.2.4 HS400 AC timing—eMMC5.0 only

The following figure depicts the timing of HS400, and the subsequent table lists the HS400 timing characteristics. Be aware that only data is sampled on both edges of the clock (not applicable to CMD). The CMD input/output timing for HS400 mode is the same as CMD input/output timing for SDR104 mode. Check parameters SD5, SD6, and SD7 in [Table 34](#) for CMD input/output timing for HS400 mode.

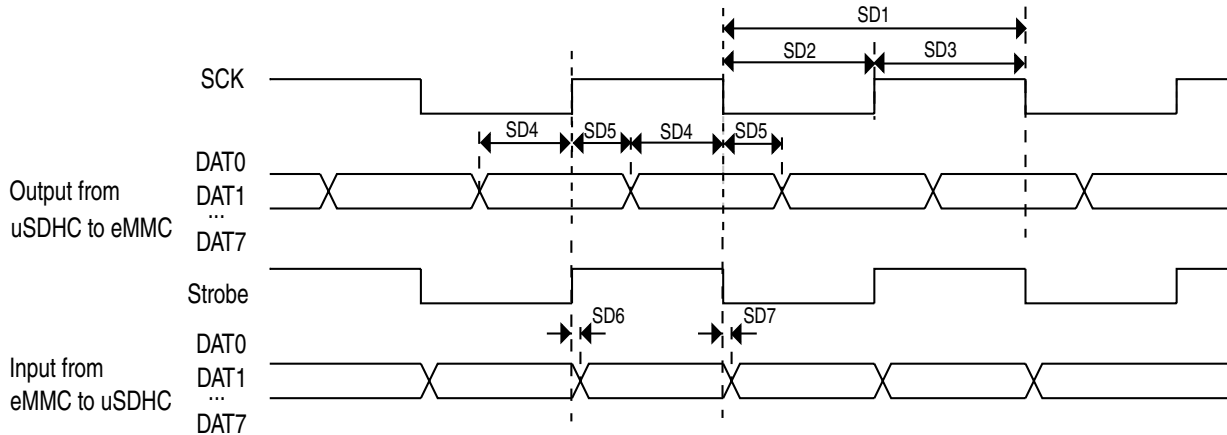

Figure 14. HS400 timing

Table 33. HS400 timing specifications

ID	Parameter	Symbols	Min	Max	Unit
Card Input clock					
SD1	Clock Frequency	fPP	0	192	MHz
SD2	Clock Low Time	tCL	$0.46 \times tCLK$	$0.54 \times tCLK$	ns
SD3	Clock High Time	tCH	$0.46 \times tCLK$	$0.54 \times tCLK$	ns
uSDHC Output/Card inputs DAT (Reference to SCK)					
SD4	Output Skew from Data of Edge of SCK	tOSkew1	0.45	—	ns
SD5	Output Skew from Edge of SCK to Data	tOSkew2	0.45	—	ns
uSDHC input/Card Outputs DAT (Reference to Strobe)					
SD6	uSDHC input skew	tRQ	—	0.45	ns
SD7	uSDHC hold skew	tRQH	—	0.45	ns

8.1.2.5 SDR50/SDR104 AC timing

The following figure shows the timing of SDR50/SDR104, and the table lists the SDR50/SDR104 timing characteristics.

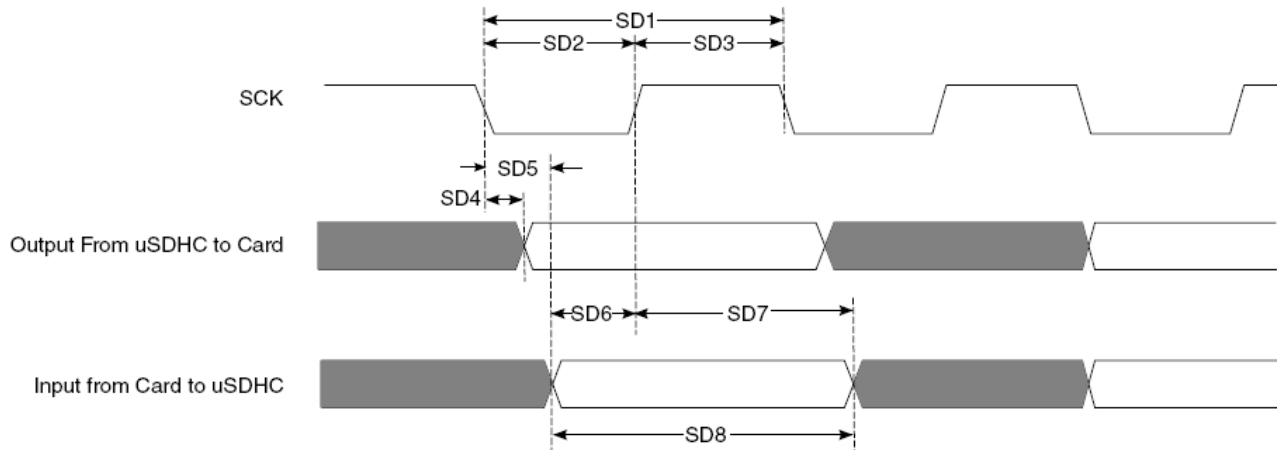

Figure 15. SDR50/SDR104 timing

Table 34. SDR50/SDR104 interface timing specification

ID	Parameter	Symbols	Min	Max	Unit
Card Input Clock					
SD1	Clock Frequency Period	t_{CLK}	4.8	—	ns
SD2	Clock Low Time	t_{CL}	$0.46 * t_{CLK}$	$0.54 * t_{CLK}$	ns
SD3	Clock High Time	t_{CH}	$0.46 * t_{CLK}$	$0.54 * t_{CLK}$	ns
uSDHC Output/Card Inputs SD_CMD, SDx_DATAx in SDR50 (Reference to CLK)					
SD4	uSDHC Output Delay	t_{OD}	-3	1	ns
uSDHC Output/Card Inputs SD_CMD, SDx_DATAx in SDR104 (Reference to CLK)					
SD5	uSDHC Output Delay	t_{OD}	-1.6	0.74	ns
uSDHC Input/Card Outputs SD_CMD, SDx_DATAx in SDR50 (Reference to CLK)					
SD6	uSDHC Input Setup Time	t_{ISU}	2.5	—	ns
SD7	uSDHC Input Hold Time	t_{IH}	1.5	—	ns
uSDHC Input/Card Outputs SD_CMD, SDx_DATAx in SDR104 (Reference to CLK) ¹					
SD8	Card Output Data Window	t_{ODW}	$0.5 * t_{CLK}$	—	ns

1. Data window in SDR100 mode is variable.

8.1.2.6 Bus operation condition for 3.3 V and 1.8 V signaling

Signaling level of SD/eMMC4.3 and eMMC4.4/4.41 modes is 3.3 V. Signaling level of SDR104/SDR50 mode is 1.8 V.

8.1.3 Flexbus switching specifications

All processor bus timings are synchronous; input setup/hold and output delay are given in respect to the rising edge of a reference clock, FB_CLK. The FB_CLK frequency may be the same as the internal system bus frequency or an integer divider of that frequency.

The following timing parameters indicate when data is latched or driven onto the external bus, relative to the Flexbus output clock (FB_CLK). All other timing relationships can be derived from these values.

Table 35. Flexbus switching specifications

Num	Parameter	Min.	Max.	Unit	Notes
	Frequency of operation <ul style="list-style-type: none"> • HSRUN mode • Normal RUN mode 	—	66 66	MHz	
FB1	Clock period <ul style="list-style-type: none"> • HSRUN mode • Normal RUN mode 	15.0 15.0	—	ns	
FB2	Address, data, and control output valid	—	13.0	ns	1
FB3	Address, data, and control output hold	1.0	—	ns	1
FB4	Data input setup	8.5	—	ns	2
FB5	Data input hold	0.0	—	ns	2

1. Specification is valid for all FB_AD[31:0], FB_BE, FB_CS_n_B, FB_OE_B, FB_RW_B, FB_TBST_B, FB_TSI_Z[1:0], FB_ALE, and FB_TS_B.
2. Specification is valid for all FB_AD[31:0].

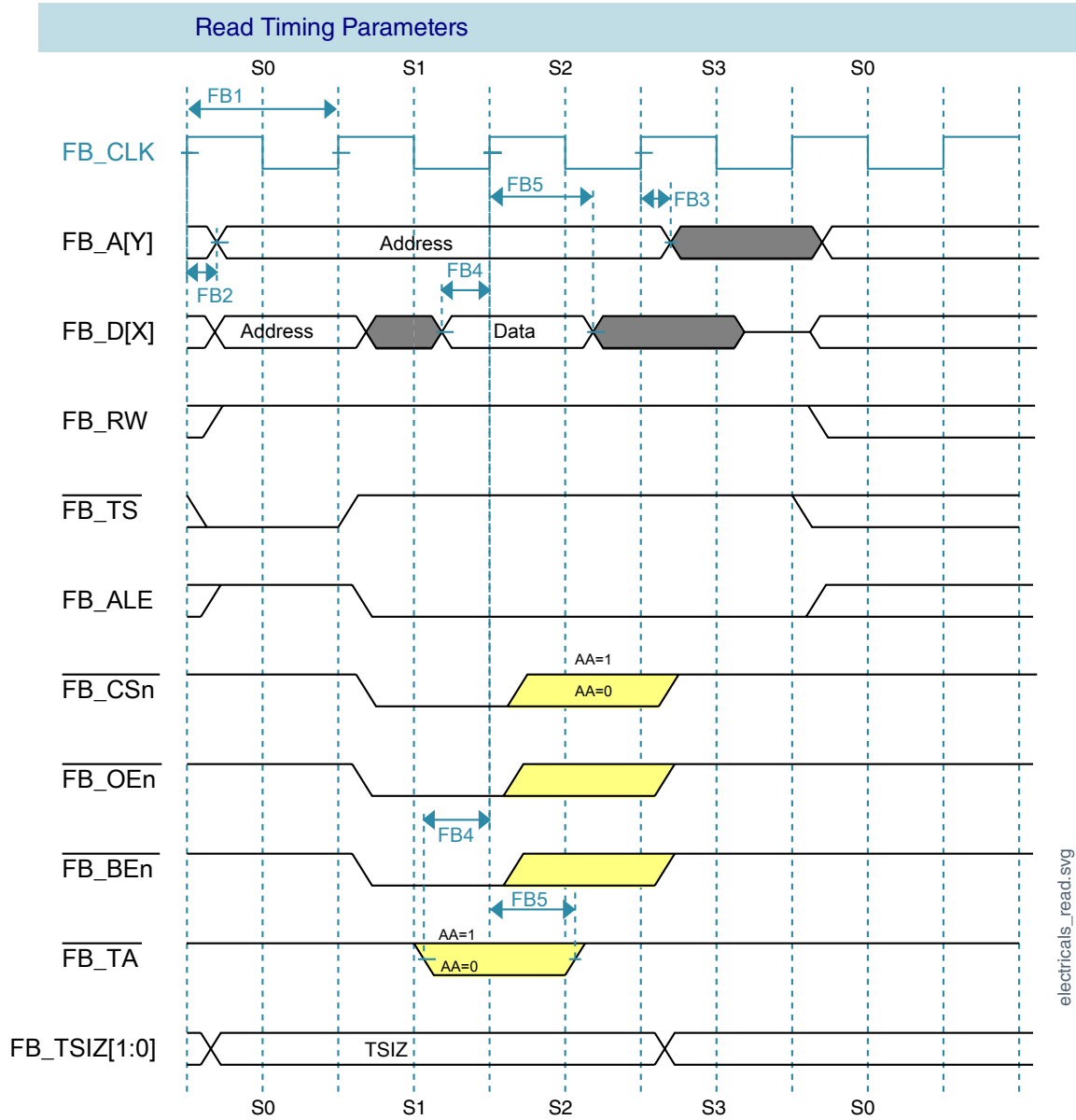
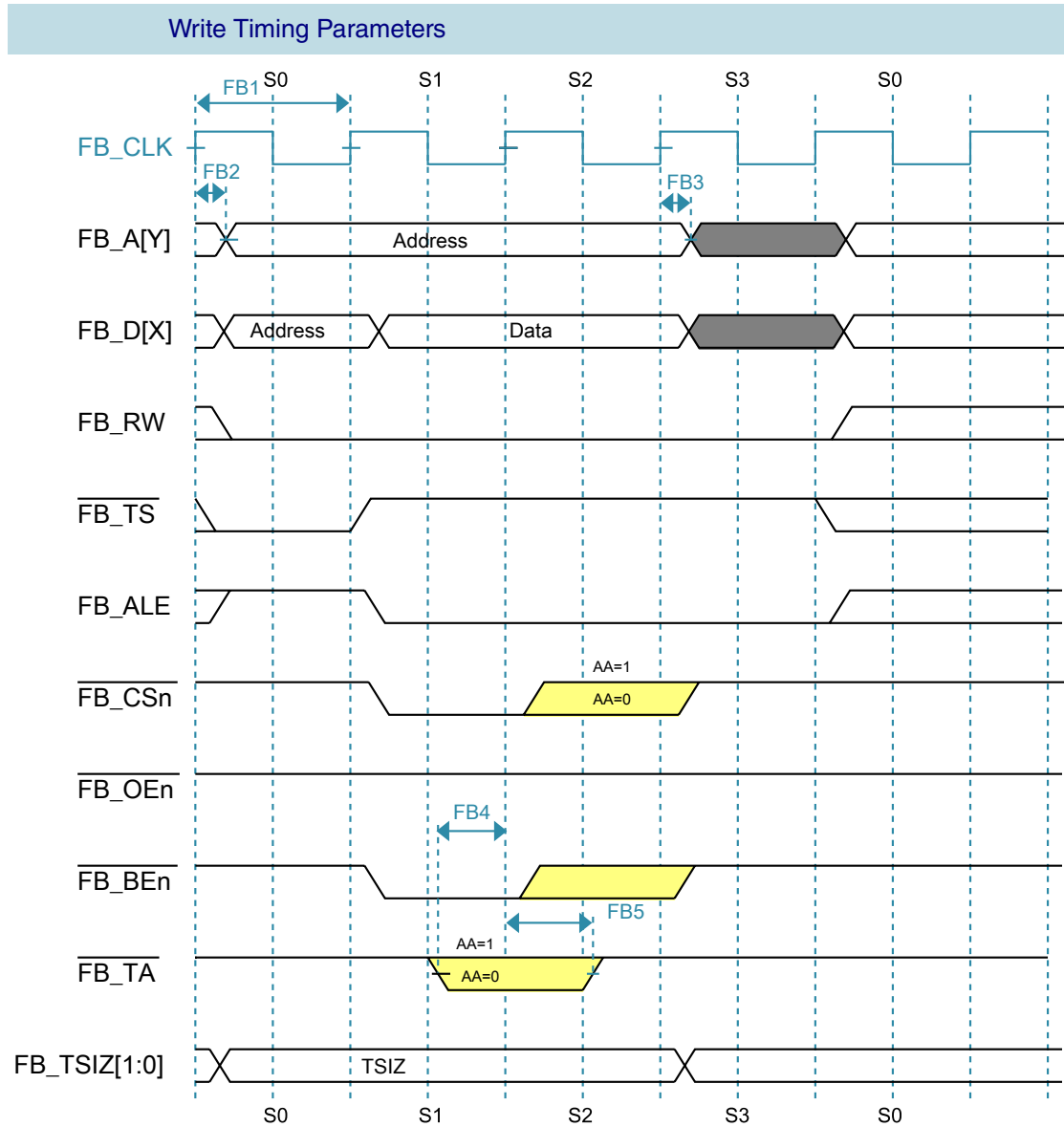

Figure 16. FlexBus read timing diagram

NOTE

The Transfer Acknowledge Signal (FB_TA) is hard-wired in the design of i.MX 7ULP, so this signal is not available.



electricals_write.svg

Figure 17. FlexBus write timing diagram

NOTE

The Transfer Acknowledge Signal (FB_TA) is hard-wired in the design of i.MX 7ULP, so this signal is not available.

8.1.4 Display, Video, and Audio Interfaces

8.1.4.1 MIPI DSI timing—application domain

The i.MX 7ULP conforms to the MIPI D-PHY electrical specifications MIPI DSI Version 1.01 and D-PHY specification Rev. 1.0 (and also DPI version 2.0, DBI version 2.0, DSC version 1.0a at protocol layer) for MIPI display port x2 lanes.

8.1.4.2 Video Input Unit timing

This section provides the timing parameters of the Video Input Unit (VIU) interface.

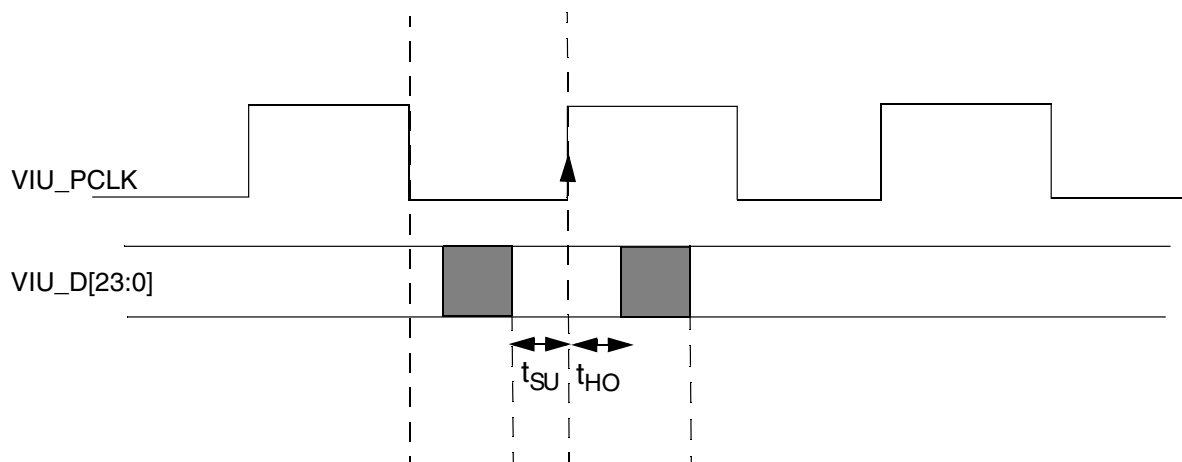

Figure 18. VIU Timing Parameters

Table 36. VIU Timing Parameters

Symbol	Characteristic	Min	Max	Unit
f_{PIX_CK}	VIU pixel clock frequency	–	66.7	MHz
t_{DSU}	VIU data setup time	9.0	–	ns
t_{DHD}	VIU data hold time	1	–	ns

8.1.5 Timer specifications—application domain

See [General switching timing specifications](#) for EWM, LPTMR, and TPM.

8.1.6 Connectivity and communications specifications—application domain

8.1.6.1 LPUART

See [General switching timing specifications](#).

8.1.6.2 Inter-Integrated Circuit Interface (I²C) timing

Table 37. I²C timing (Standard, Fast, and Fast Plus modes)

Parameter	Symbol	Standard Mode		Fast Mode		Fast-mode Plus		Unit
		Min	Max	Min	Max	Min	Max	
SCL Clock Frequency	f _{SCL}	0	100	0	400	0	1000	kHz
Hold time (repeated) START condition. After this period, the first clock pulse is generated.	t _{HD} ; STA	4	—	0.6	—	0.26	—	μs
LOW period of the SCL clock	t _{LOW}	4.7	—	1.3	—	0.5	—	μs
HIGH period of the SCL clock	t _{HIGH}	4	—	0.6	—	0.26	—	μs
Set-up time for a repeated START condition	t _{SU} ; STA	4.7	—	0.6	—	0.26	—	μs
Data hold time for I ² C bus devices	t _{HD} ; DAT	0 ¹	3.45 ²	0 ³	0.9 ¹	0	—	μs
Data set-up time	t _{SU} ; DAT	250 ⁴	—	100 ^{2, 5}	—	50	—	ns
Rise time of SDA and SCL signals	t _r	—	1000	20 +0.1C _b ⁶	300	20 +0.1C _b ⁷	120	ns
Fall time of SDA and SCL signals	t _f	—	300	20 +0.1C _b ⁵	300	20 +0.1C _b ⁵	120	ns
Set-up time for STOP condition	t _{SU} ; STO	4	—	0.6	—	0.26	—	μs
Bus free time between STOP and START condition	t _{BUF}	4.7	—	1.3	—	0.5	—	μs
Pulse width of spikes that must be suppressed by the input filter	t _{SP}	N/A	N/A	0	50	0	50	ns

1. The master mode I²C deasserts ACK of an address byte simultaneously with the falling edge of SCL. If no slaves acknowledge this address byte, then a negative hold time can result, depending on the edge rates of the SDA and SCL lines.
2. The maximum t_{HD}; DAT must be met only if the device does not stretch the LOW period (t_{LOW}) of the SCL signal.
3. Input signal Slew = 10 ns and Output Load = 50 pF
4. Set-up time in slave-transmitter mode is 1 IPBus clock period, if the TX FIFO is empty.
5. A Fast mode I²C bus device can be used in a Standard mode I²C bus system, but the requirement t_{SU}; DAT ≥ 250 ns must then be met. This is automatically the case if the device does not stretch the LOW period of the SCL signal. If such a device does stretch the LOW period of the SCL signal, then it must output the next data bit to the SDA line t_{rmax} + t_{SU}; DAT = 1000 + 250 = 1250 ns (according to the Standard mode I²C bus specification) before the SCL line is released.
6. C_b = total capacitance of the one bus line in pF.
7. C_b = total capacitance of the one bus line in pF.

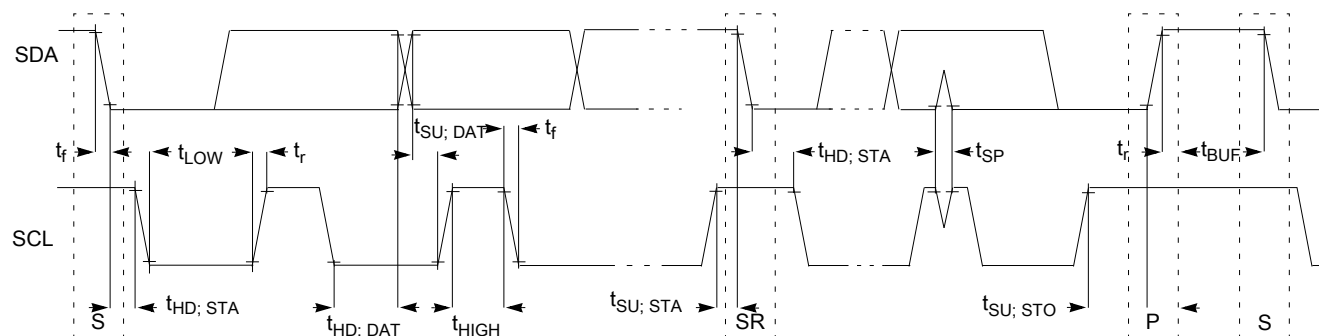

Figure 19. Timing definition for standard, fast, and fast plus devices on the I²C bus

Table 38. I²C timing (High speed mode)

Parameter	Symbol	Minimum	Maximum	Unit
SCLH Clock Frequency	f_{SCLH}	0	3.4	MHz
Hold time (repeated) START condition. After this period, the first clock pulse is generated.	$t_{HD; STA}$	160	—	ns
LOW period of the SCLH clock	t_{LOW}	160	—	ns
HIGH period of the SCLH clock	t_{HIGH}	60	—	ns
Set-up time for a repeated START condition	$t_{SU; STA}$	160	—	ns
Data hold time for I ² C bus devices	$t_{HD; DAT}$	0	70	ns
Data set-up time	$t_{SU; DAT}$	10	—	ns
Rise time of SCLH signal	t_{rCL}	10	40	ns
Rise time of SCLH signal after a repeated START condition and after an acknowledge bit	t_{rCL1}	10	80	ns
Fall time of SCLH signal	t_{fCL}	10	40	ns
Rise time of SDAH signal	t_{rDA}	10	80	ns
Fall time of SDAH signal	t_{fDA}	10	80	ns
Set-up time for STOP condition	$t_{SU; STO}$	160	—	ns
Pulse width of spikes that must be suppressed by the input filter	t_{SP}	0	10	ns

8.1.6.3 Low Power Serial Peripheral Interface (LPSPI) switching specifications—application domain

The Low Power Serial Peripheral Interface (LPSPI) provides a synchronous serial bus with master and slave operations. Many of the transfer attributes are programmable. The following tables provide timing characteristics for classic LPSPI timing modes. See the LPSPI chapter of the chip reference manual for information about the modified transfer formats used for communicating with slower peripheral devices.

All timing is shown with respect to 20% V_{DD} and 80% V_{DD} thresholds, unless noted, as well as input signal transitions of 3 ns and a 30 pF maximum load on all LPSPI pins.

Table 39. LPSPI master mode switching specifications

Num.	Symbol	Description	Min	Max	Unit	Note
1	f_{op}	Frequency of operation: LPSPI0-1 LPSPI2-3	$f_{periph}/2048$ $f_{periph}/2048$	30 50	MHz	1
2	t_{SPSCK}	SPSCK period: LPSPI0-1 LPSPI2-3	33.33 16.67	$2048 \times t_{periph}$ $2048 \times t_{periph}$	ns	2
3	t_{Lead}	Enable lead time	1/2	—	t_{SPSCK}	—
4	t_{Lag}	Enable lag time	1/2	—	t_{SPSCK}	—
5	t_{WSPSCK}	Clock (SPSCK) high or low time	$(t_{SPSCK}/2) - 2$	$(t_{SPSCK}/2) + 2$	ns	—
6	t_{SU}	Data setup time (inputs): LPSPI0-1 LPSPI2-3	16.0 11.6	—	ns	—
7	t_{HI}	Data hold time (inputs)	0	—	ns	—
8	t_v	Data valid (after SPSCK edge): LPSPI0-1 LPSPI2-3	—	17.2 10.0	ns	—
9	t_{HO}	Data hold time (outputs)	-0.7	—	ns	—

1. Max frequency is also limited to $f_{periph}/2$, where f_{periph} is programmable for each LPSPI n module
2. $t_{periph} = 1/f_{periph}$

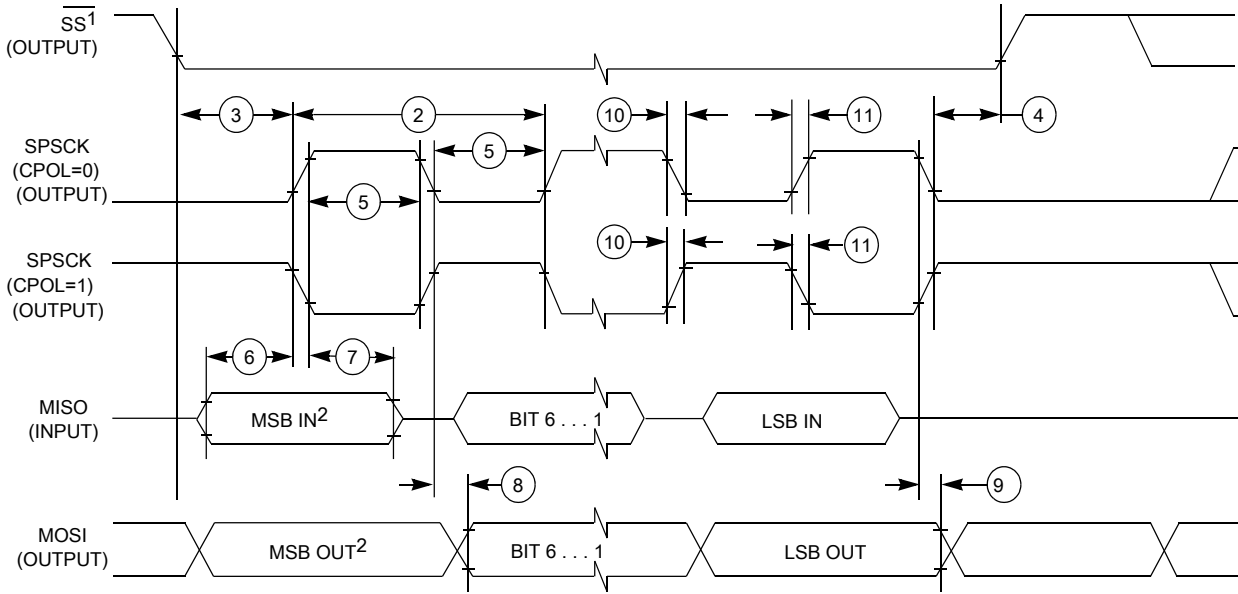

- 1. If configured as an output.
- 2. LSBF = 0. For LSBF = 1, bit order is LSB, bit 1, ..., bit 6, MSB.

Figure 20. LPSPI master mode timing (CPHA = 0)

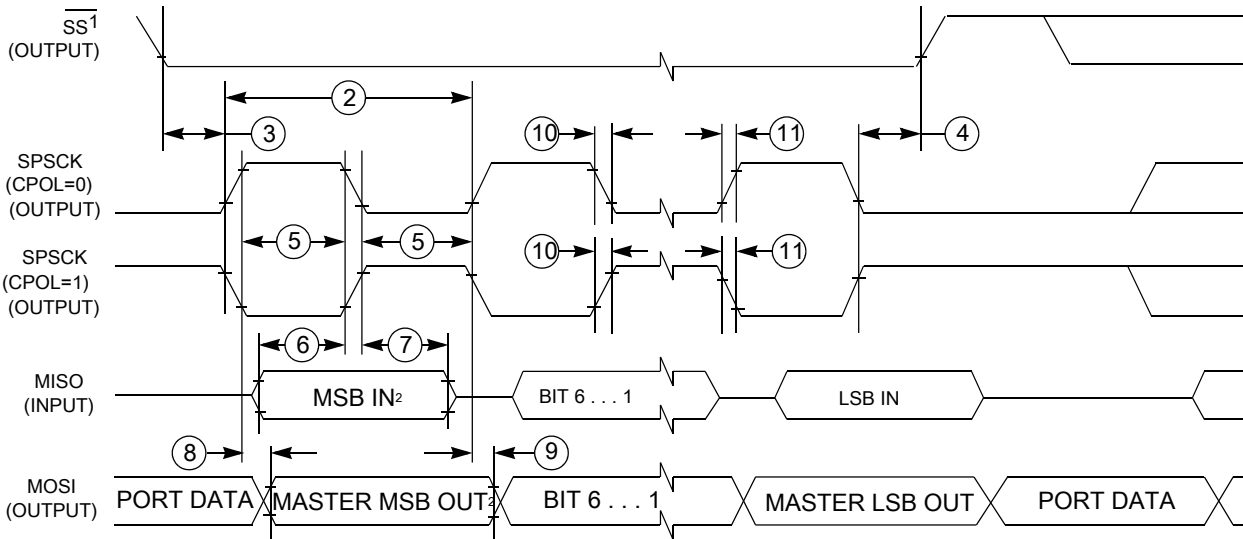

- 1. If configured as output
- 2. LSBF = 0. For LSBF = 1, bit order is LSB, bit 1, ..., bit 6, MSB.

Figure 21. LPSPI master mode timing (CPHA = 1)

Table 40. LPSPI slave mode switching specifications

Num.	Symbol	Description	Min	Max	Unit	Note
1	f_{op}	Frequency of operation: LPSPI0-1 LPSPI2-3	0 0	15 25	MHz	1

Table continues on the next page...

**Table 40. LPSPI slave mode switching specifications
(continued)**

Num.	Symbol	Description	Min	Max	Unit	Note
2	t_{SPSCK}	SPSCK period: LPSPI0-1 LPSPI2-3	66.6 40	— —	ns	—
3	$t_{SS2SPSCK}$	SPI_SS valid to SPI_SPSCK delay	1	—	t_{periph}	2
4	$t_{SPSCK2SS}$	SPI_SPSCK to SPI_SS invalid delay	1	—	t_{periph}	2
5	t_{WSPSCK}	Clock (SPSCK) high or low time	$(t_{SPSCK}/2) - 2$	$(t_{SPSCK}/2) + 2$	ns	—
6	t_{SU}	Data setup time (inputs): LPSPI0-1 LPSPI2-3	9 4.2	— —	ns	—
7	t_{HI}	Data hold time (inputs): LPSPI0-1 LPSPI2-3	6 3.9	— —	ns	—
8	$t_{SPSCK2DV}$	SPI_SPSCK to SPI_MISO data valid (output data valid): LPSPI0-1 LPSPI2-3	— —	20.0 15.5	ns	—
9	$t_{SPSCK2DH}$	SPI_SPSCK to SPI_MISO data invalid (output data hold): LPSPI0-1 LPSPI2-3	2.0 2.0	— —	ns	—
10	t_{SS2DRV}	SPI_SS active to SPI_MISO driven	18.1	—	ns	—
11	t_{SS2HIZ}	SPI_SS inactive to SPI_MISO not driven	18	—	ns	—

1. Max frequency is also limited to $f_{periph}/4$, where f_{periph} is programmable for each LPSPI n module
2. $t_{periph} = 1/f_{periph}$

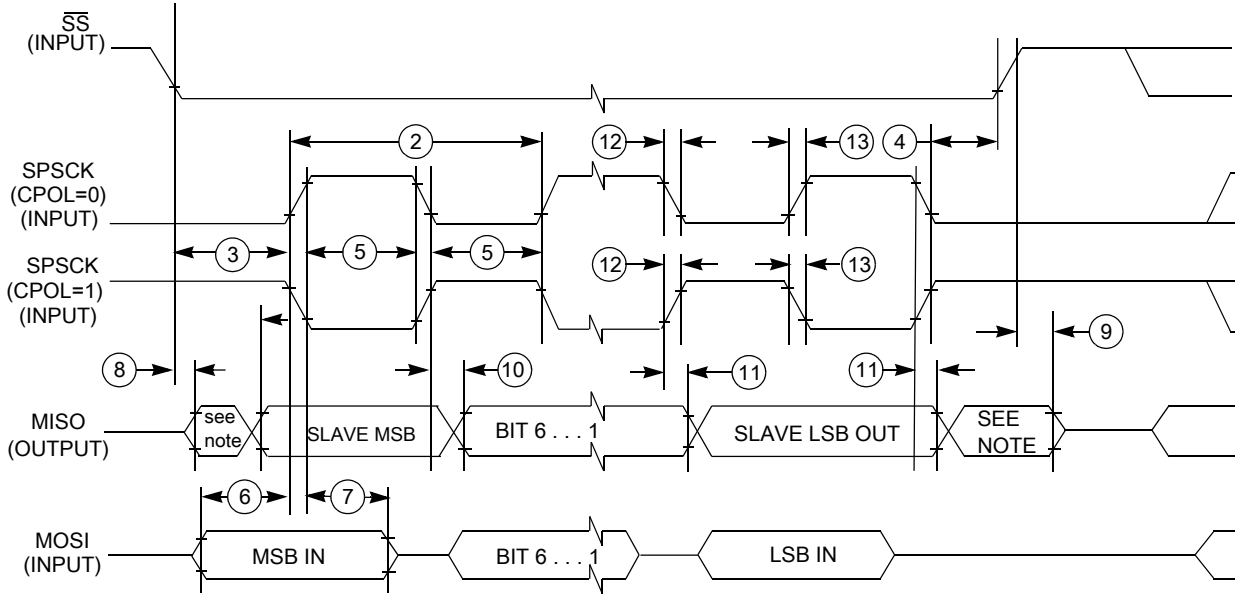

NOTE: Not defined

Figure 22. LPSPI slave mode timing (CPHA = 0)

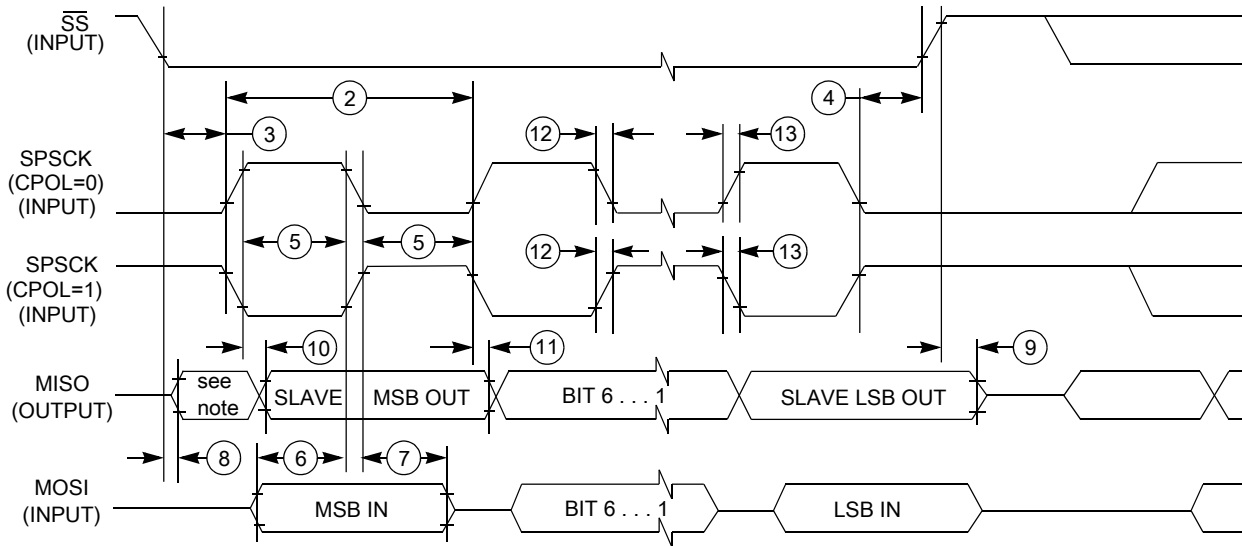

NOTE: Not defined

Figure 23. LPSPI slave mode timing (CPHA = 1)

8.1.6.4 USB Full Speed Transceiver and High Speed PHY specifications

This section describes the High Speed USB PHY parameters. The high speed PHY is capable of full and low speed signaling as well.

The USB PHY meets the electrical compliance requirements defined in the Universal Serial Bus Revision 2.0 Specification with the amendments below.

- USB ENGINEERING CHANGE NOTICE
 - Title: 5V Short Circuit Withstand Requirement Change
 - Applies to: Universal Serial Bus Specification, Revision 2.0
- Errata for USB Revision 2.0 April 27, 2000 as of 12/7/2000
- USB ENGINEERING CHANGE NOTICE
 - Title: Pull-up/Pull-down resistors
 - Applies to: Universal Serial Bus Specification, Revision 2.0
- USB ENGINEERING CHANGE NOTICE
 - Title: Suspend Current Limit Changes
 - Applies to: Universal Serial Bus Specification, Revision 2.0
- On-The-Go and Embedded Host Supplement to the USB Revision 2.0 Specification
 - Revision 2.0 plus errata and ecn June 4, 2010
- Battery Charging Specification (available from USB-IF)
 - Revision 1.2, December 7, 2010

USB0_VBUS pin is a detector function which is 5v tolerant and complies with the above specifications without needing any external voltage division components.

8.1.6.5 USB HSIC timings

This section describes the electrical information of the USB HSIC port.

NOTE

HSIC is a DDR signal. The following timing specifications are for both rising and falling edges.

8.1.6.5.1 USB HSIC transmit timing

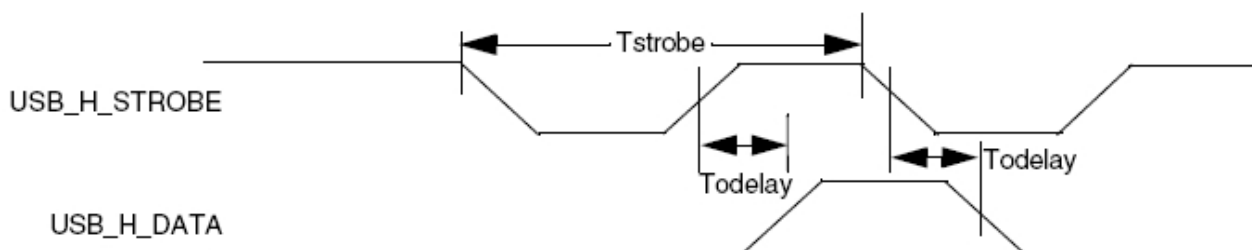

Figure 24. USB HSIC transmit waveform

Table 41. USB HSIC transmit parameters

Name	Parameter	Min	Max	Unit	Comment
T _{strobe}	strobe period	4.166	4.167	ns	—
T _{odelay}	data output delay time	0	4.1	ns	Measured at 50% point
T _{slew}	strobe/data rising/falling time	1.2	—	V/ns	Average of 30% and 70% voltage levels

8.1.6.5.2 USB HSIC receive timing

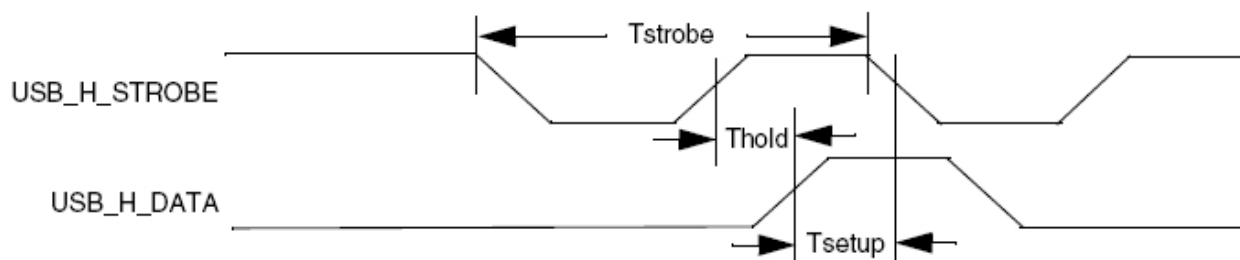

Figure 25. USB HSIC receive waveform

Table 42. USB HSIC receive parameters

Name	Parameter	Min	Max	Unit	Comment
T _{strobe}	strobe period	4.166	4.167	ns	—
T _{hold}	data hold time	0.3	—	ns	Measured at 50% point
T _{setup}	data setup time	0.367	—	ns	Measured at 50% point
T _{slew}	strobe/data rising/falling time	1.2	—	V/ns	Average of 30% and 70% voltage levels

8.1.6.6 Parallel interface (ULPI interface)

Electrical characteristics and timing parameters for the parallel interface are presented in the subsequent sections. The following table lists the parallel interface signal definitions.

Table 43. USB signal definitions—Parallel (ULPI) interface

Name	Direction	Signal description
USB_CLK	In	Interface clock. All interface signals are synchronous to clock.
USB_DAT[7:0]	I/O	Bidirectional data bus, driven low by the link during Idle. Bus ownership is determined by Direction.

Table continues on the next page...

Table 43. USB signal definitions—Parallel (ULPI) interface (continued)

Name	Direction	Signal description
USB_DIR	In	Direction. Controls the direction of the Data bus.
USB_STP	Out	Stop. The link asserts this signal for 1 clock cycle to stop the data stream currently on the bus.
USB_NXT	In	Next. The PHY asserts this signal to throttle the data.

The following figure shows the USB transmit/receive timing diagram in parallel mode.

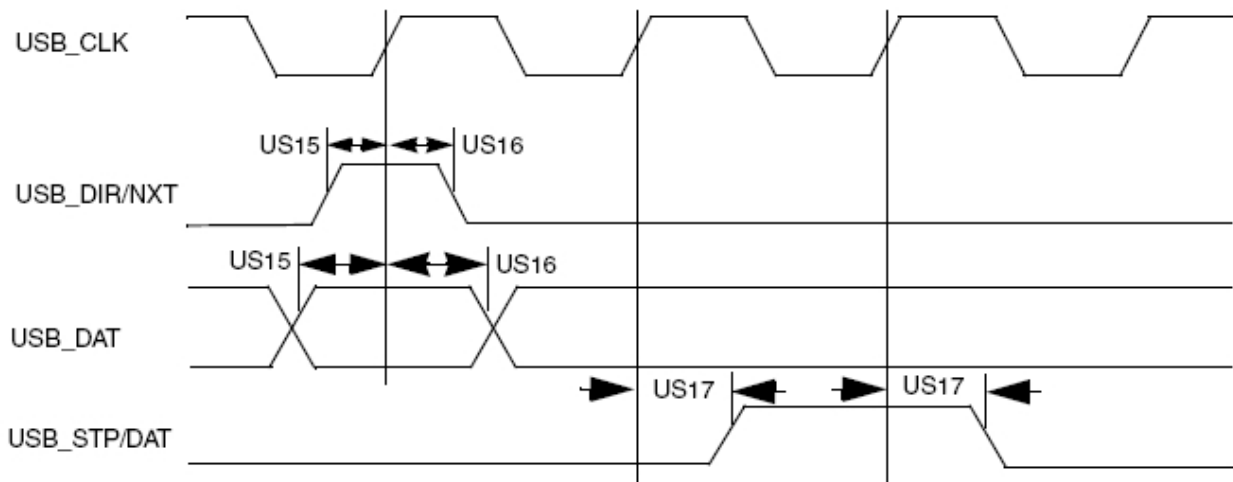

Figure 26. USB Transmit and Receive timing diagram—Parallel (ULPI) mode

The following table lists the USB Transmit and Receive timing parameters in Parallel (ULPI) mode.

Table 44. USB Transmit and Receive Timing Parameters—Parallel (ULPI) Mode

ID	Parameter	Min	Max	Unit	Conditions/ reference signal
US15	Setup time (DIR and NXT in, DAT in)	6.0	—	ns	14 pF
US16	Hold time (DIR and NXT in, DAT in)	0	—	ns	14 pF
US17	Output delay time (STP out, DAT out)	0	9.0	ns	14 pF

9 Specifications—real-time domain

9.1 Power sequencing—real-time domain

See [Power sequencing—system](#).

9.2 Peripheral operating requirements and behaviors—real-time domain

9.2.1 QuadSPI AC specifications

- All data is based on a negative edge data launch from the device and a positive edge data capture, as shown in the timing diagrams in this section.
- Measurements are with a load of 10 pF on output pins. Input slew: 2 ns
- Timings assume a setting of 0x0004_000x for QuadSPI_SMPR register (see the reference manual for details).

SDR mode

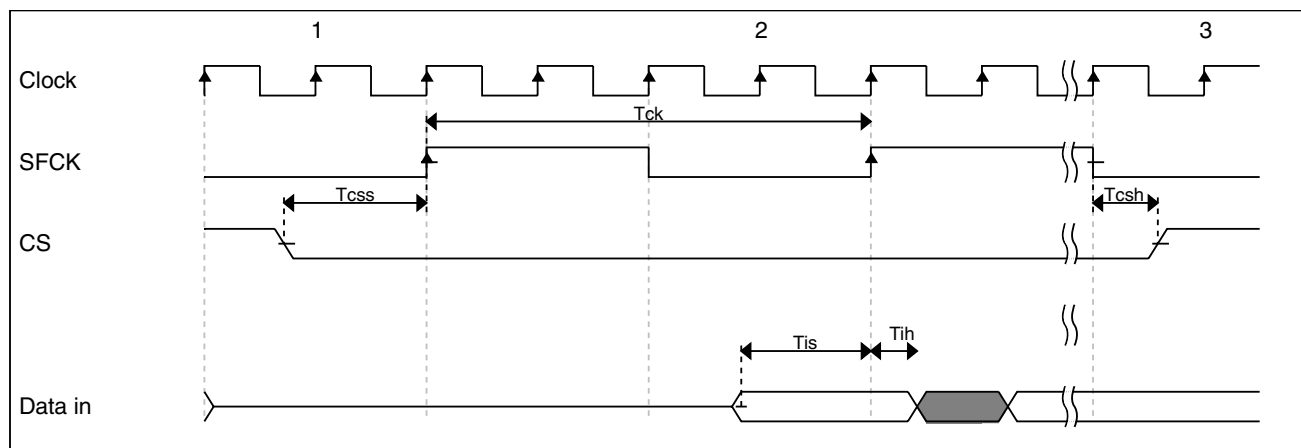

Figure 27. QuadSPI input timing (SDR mode) diagram

NOTE

- The timing values below are with default settings for sampling registers like QuadSPI_SMPR.
- A negative time indicates the actual capture edge inside the device is earlier than clock appearing at pad.
- Frequency calculator guidelines (Max read frequency) for any frequency: $SCR > (Flash\ access\ time)_{max} + (Tis)_{max}$

- All board delays need to be added appropriately
- Input hold time being negative does not have any implication or max achievable frequency

Table 45. QuadSPI input timing (SDR mode) specifications

Symbol	Parameter	Value		Unit
		Min	Max	
T_{is}	Setup time for incoming data	6	—	ns
T_{ih}	Hold time requirement for incoming data	1	—	ns

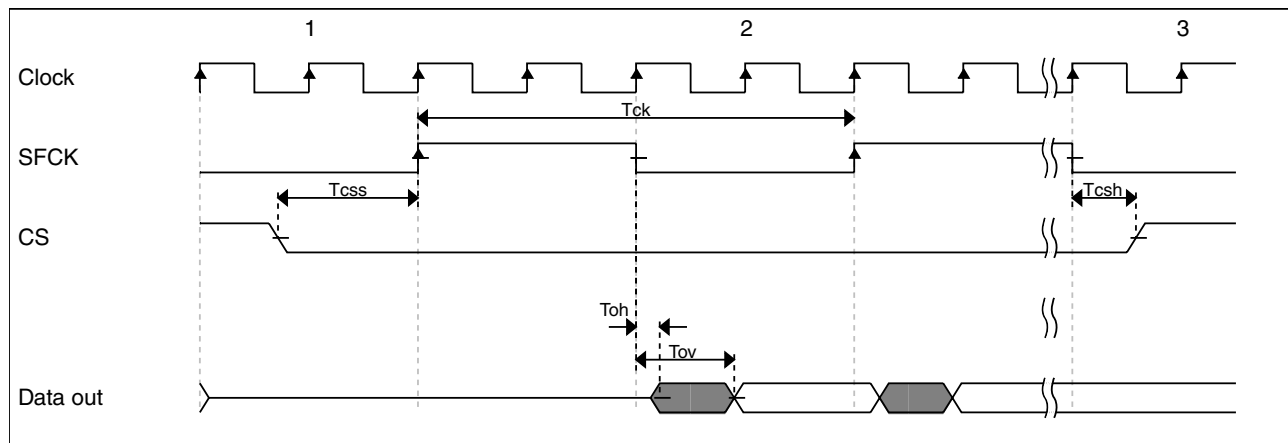

Figure 28. QuadSPI output timing (SDR mode) diagram

Table 46. QuadSPI output timing (SDR mode) specifications

Symbol	Parameter	Value		Unit
		Min	Max	
T_{ov}	Output Data Valid	—	2	ns
T_{oh}	Output Data Hold	3	—	ns
T_{ck}	SCK clock period	—	99	MHz
T_{css}	Chip select output setup time	5	—	ns
T_{csh}	Chip select output hold time	5	—	ns

NOTE

For any frequency, setup and hold specifications of the memory should be met.

DDR Mode

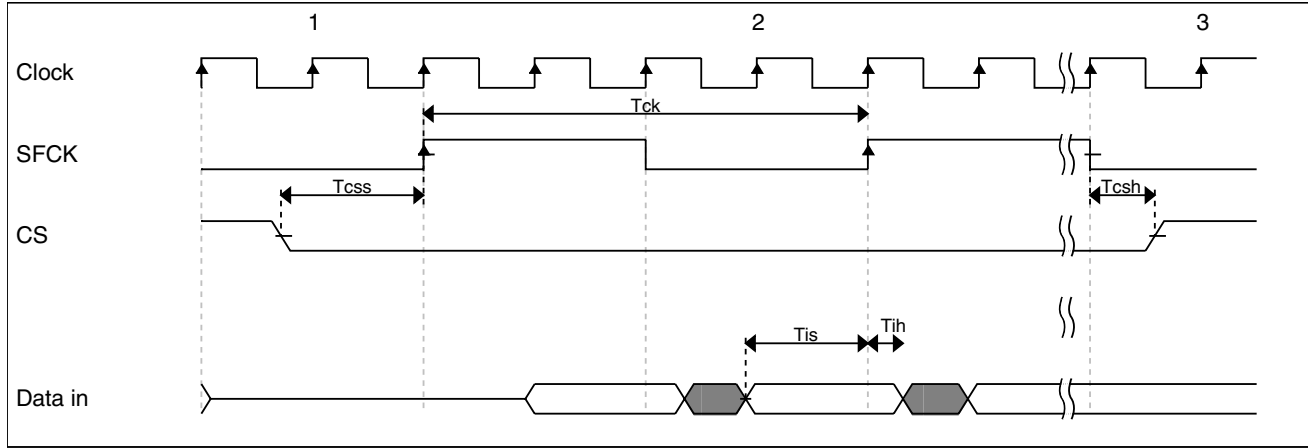

Figure 29. QuadSPI input timing (DDR mode) diagram

NOTE

- Parameters assume a load of 10 pf
- The parameters are for setting of hold condition in register QuadSPI_SMPR[DDRSMP]
- Read frequency calculations should be: $SCK/2 > (\text{flash access time}) + \text{Setup } (T_{is}) - (\text{edge number}) \times SCK/4$

Table 47. QuadSPI input timing (DDR mode) specifications

Symbol	Parameter	Value		Unit
		Min	Max	
T_{is}	Setup time for incoming data	6	—	ns
T_{ih}	Hold time requirement for incoming data	1	—	ns

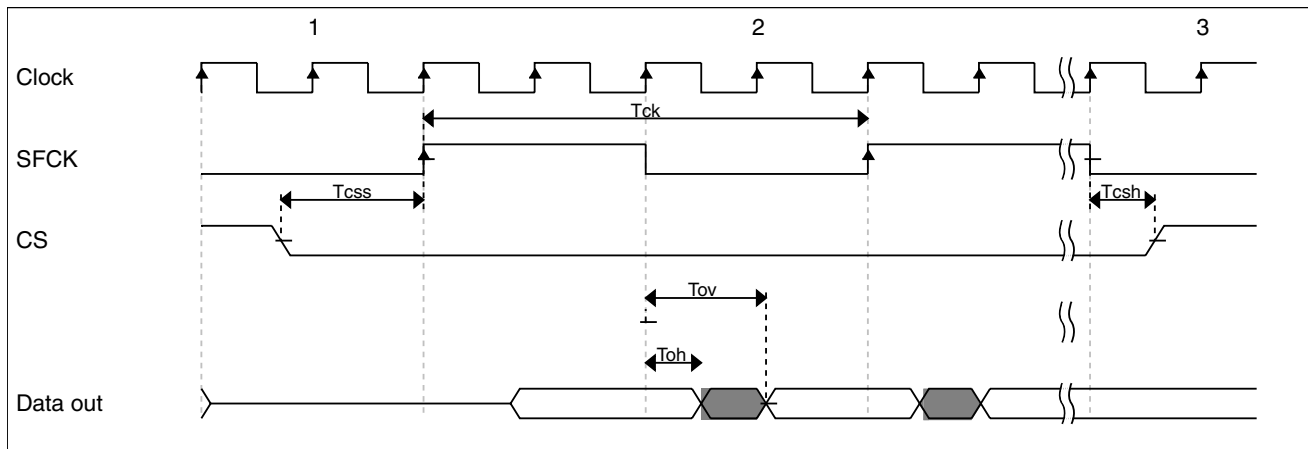
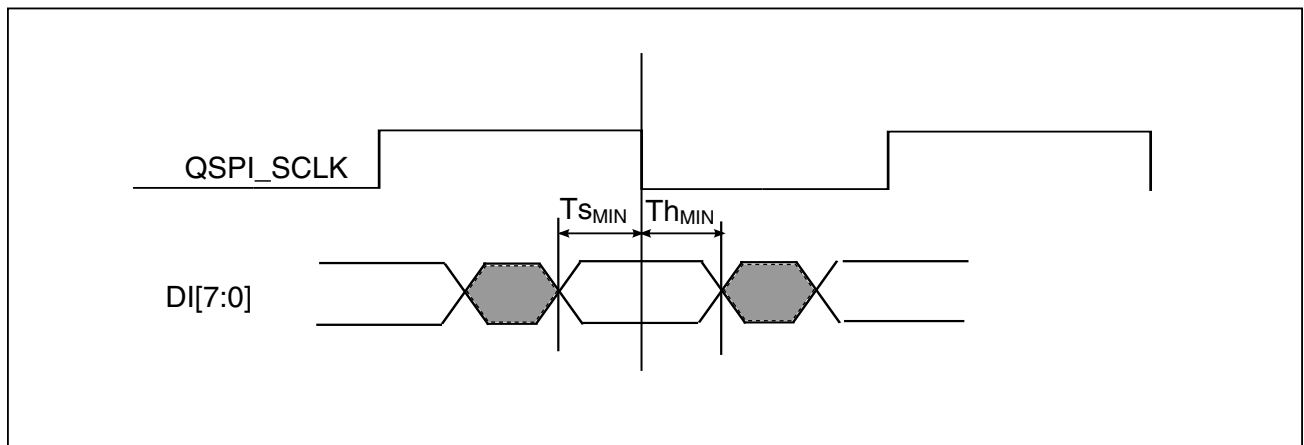

Figure 30. QuadSPI output timing (DDR mode) diagram

Table 48. QuadSPI output timing (DDR mode) specifications

Symbol	Parameter	Value		Unit
		Min	Max	
T_{ov}	Output Data Valid	-	1.75	ns
T_{oh}	Output Data Hold	2	-	ns
T_{ck}	SCK clock period	-	60	MHz
T_{css}	Chip select output setup time	2.7	-	Clk(sck)
T_{csh}	Chip select output hold time	5.62	-	Clk(sck)

Hyperflash mode

**Figure 31. QuadSPI input timing (Hyperflash mode) diagram****Table 49. QuadSPI input timing (Hyperflash mode) specifications**

Symbol	Parameter	Value		Unit
		Min	Max	
$T_{S_{MIN}}$	Setup time for incoming data	6	-	ns
$T_{h_{MIN}}$	Hold time requirement for incoming data	1	-	ns

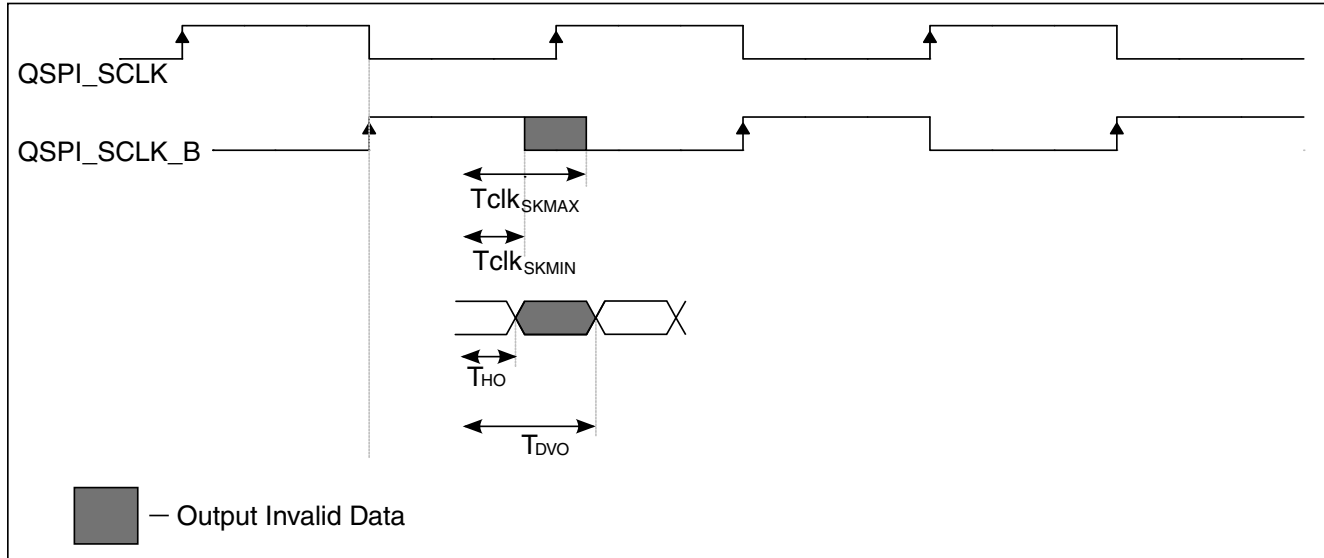

Figure 32. QuadSPI output timing (Hyperflash mode) diagram

Table 50. QuadSPI output timing (Hyperflash mode) specifications

Symbol	Characteristic	Min	Max	Unit
TdvMAX	Output Data Valid	–	4.3	ns
Tho	Output Data Hold	1.3	–	ns
TclkSKMAX	Ck to DQS skew max	–	$CK/2 + 0.8$	ns
TclkSKMIN	Ck to DQS skew min	$-(CK/2 + 1.2)$	–	ns
Tck	CK clock period	–	70	MHz

NOTE

Maximum QSPI clock frequency = 70 MHz.

9.2.2 Analog modules

9.2.2.1 12-bit ADC electrical specifications

All ADC channels meet the 12-bit single-ended accuracy specifications.

Table 51. ADC Electrical Specifications ($V_{REFH}=VDD_ANA_18$ and $V_{ADIN}_{max} \leq V_{REFH}$)

Symbol	Description	Min	Typ	Max	Unit	Notes
VADIN	Input voltage	VREFL		VREFH	V	
CADIN	Input capacitance		4.5		pF	
RADIN	Input resistance		500		Ω	

Table continues on the next page...

Table 51. ADC Electrical Specifications (VREFH=VDD_ANA_18 and VADIN_{max}≤VREFH) (continued)

Symbol	Description	Min	Typ	Max	Unit	Notes
RAS	Analog source resistance			5	KΩ	1
fADCK	ADC Conversion clock frequency	8		66	MHz	
Csample	Sample cycles	3.5		131.5		2
Ccompare	Fixed compare cycles		17.5		cycles	
Cconversion	Conversion cycles	Cconversion= Csample + Ccompare			cycles	
TUE	Total unadjusted Error		-14 to -2		LSB	3
DNL	Differential nonlinearity		±1.2		LSB	3,4
INL	Integral nonlinearity		±1.2		LSB	3,4
ENOB	Effective number of bits					5
	Single-ended mode					
	Avg = 1		10.5			
	Avg = 2		10.8			
	Avg = 16		11.4			
	Differential mode					
	Avg = 1		11.4			
	Avg = 2		—			
SINAD	Signal to noise plus distortion	SINAD=6.02 x ENOB + 1.76			dB	
EFS	Full-scale error		-4		LSB	3
EZS	Zero-scale error		0.05		LSB	3
EIL	Input leakage error	RAS * lin			mV	

1. This resistance is external to the SoC. To achieve the best results, the analog source resistance must be kept as low as possible. The results in this data sheet were derived from a system that had < 15 Ω analog source resistance. The RAS/CAS time constant should be kept to < 1 ns.
2. See [Sample time vs. RAS](#).
3. 1 LSB = (VREFH - VREFL)/2N, N=12
4. ADC conversion clock at max frequency and using linear histogram.
5. Input data used for test was 1 kHz sine wave.

Table 52. ADC electrical specifications (VREFH=1.68 V and VADIN_{max}≤VDD_PTA_{max})¹

Symbol	Description	Min	Typ ²	Max	Unit	Notes
VADIN	Input voltage— Port A	VREFL		VDD_PTA _{max}	V	
	Input voltage— Port B			VDD_PTB _{max}		
CADIN	Input capacitance		4.5		pF	

Table continues on the next page...

**Table 52. ADC electrical specifications (VREFH=1.68 V and VADIN_{max}≤VDD_PTA_{max})¹
(continued)**

Symbol	Description	Min	Typ ²	Max	Unit	Notes
RADIN	Input resistance		1		KΩ	
RAS	Analog source resistance			5	KΩ	3
fADCK	ADC conversion clock frequency	8		66	MHz	
Csample	Sample cycles	3.5		131.5		4
Ccompare	Fixed compare cycles		17.5		Cycles	
Cconversion	Conversion cycles	Cconversion= Csample + Ccompare			Cycles	
TUE	Total unadjusted error		-14 to -2		LSB	5
DNL	Differential nonlinearity		±1.2		LSB	5,6
INL	Integral nonlinearity		±1.2		LSB	5,6
ENOB	Effective Number of Bits					7
	Single-ended mode					
	Avg = 1		10.3			
	Avg = 2		10.6			
	Avg = 16		11.3			
	Differential mode					
	Avg = 1		11.2			
	Avg = 2		—			
Avg = 16		—				
SINAD	Signal to noise plus distortion	SINAD=6.02 x ENOB + 1.76			dB	
EFS	Full-scale error		-4		LSB	5
EZS	Zero-scale error		0.05		LSB	5
EIL	Input leakage error	RAS * lin			mV	

1. Values in this table are based on design simulations.
2. Typical values assume VDD_ANA_18 = 1.8 V, Temp = 25 °C, fACLK = Max, unless otherwise stated. Typical values are for reference only, and are not tested in production.
3. This resistance is external to the SoC. To achieve the best results, the analog source resistance must be kept as low as possible. The results in this data sheet were derived from a system that had < 15 Ω analog source resistance. The RAS/CAS time constant should be kept to < 1 ns.
4. See [Sample time vs. RAS](#).
5. 1 LSB = (VREFH - VREFL)/2N, N=12
6. ADC conversion clock at max frequency and using linear histogram.
7. Input data used for test was 1 kHz sine wave.

Table 53. ADC electrical specifications ($1V \leq VREFH < VDD_ANA18_{MIN}$ and $VADIN_{MAX} \leq VREFH$)¹

Symbol	Description	Min	Typ ²	Max	Unit	Notes
VADIN	Input voltage	VREFL		VREFH	V	
CADIN	Input capacitance		4.5		pF	
RADIN	Input resistance		500		Ω	
RAS	Analog source resistance			5	K Ω	3
fADCK	ADC conversion clock frequency	8		44	MHz	
Csample	Sample cycles	3.5		131.5		4
Ccompare	Fixed compare cycles		17.5		Cycles	
Cconversion	Conversion cycles	Cconversion= Csample + Ccompare			Cycles	
TUE	Total unadjusted error		-14 to -2		LSB	5
DNL	Differential nonlinearity		± 1.2		LSB	5,6
INL	Integral nonlinearity		± 1.2		LSB	5,6
ENOB	Effective number of bits					
	Single-ended mode					
	Avg = 1		9.8			
	Avg = 2		10.2			
	Avg = 16		11.1			
	Differential mode					
	Avg = 1		10.7			
	Avg = 2		—			
Avg = 16		—				
SINAD	Signal to noise plus distortion	SINAD=6.02 x ENOB + 1.76			dB	
EFS	Full-scale error		-4		LSB	5
EZS	Zero-scale error		0.05		LSB	5
EIL	Input leakage error	RAS * Iin			mV	

Specifications—real-time domain

1. Values in this table are based on design simulations.
2. Typical values assume $VDD_ANA_18 = 1.8\text{ V}$, $Temp = 25\text{ }^{\circ}\text{C}$, $f_{ACLK} = \text{Max}$, unless otherwise stated. Typical values are for reference only, and are not tested in production.
3. This resistance is external to the SoC. To achieve the best results, the analog source resistance must be kept as low as possible. The results in this data sheet were derived from a system that had $< 15\ \Omega$ analog source resistance. The RAS/CAS time constant should be kept to $< 1\text{ ns}$.
4. See [Sample time vs. RAS](#).
5. $1\text{ LSB} = (VREFH - VREFL)/2N$, $N=12$
6. ADC conversion clock at max frequency and using linear histogram.
7. Input data used for test was 1 kHz sine wave.

The following figure shows a plot of the ADC sample time versus R_{AS} .

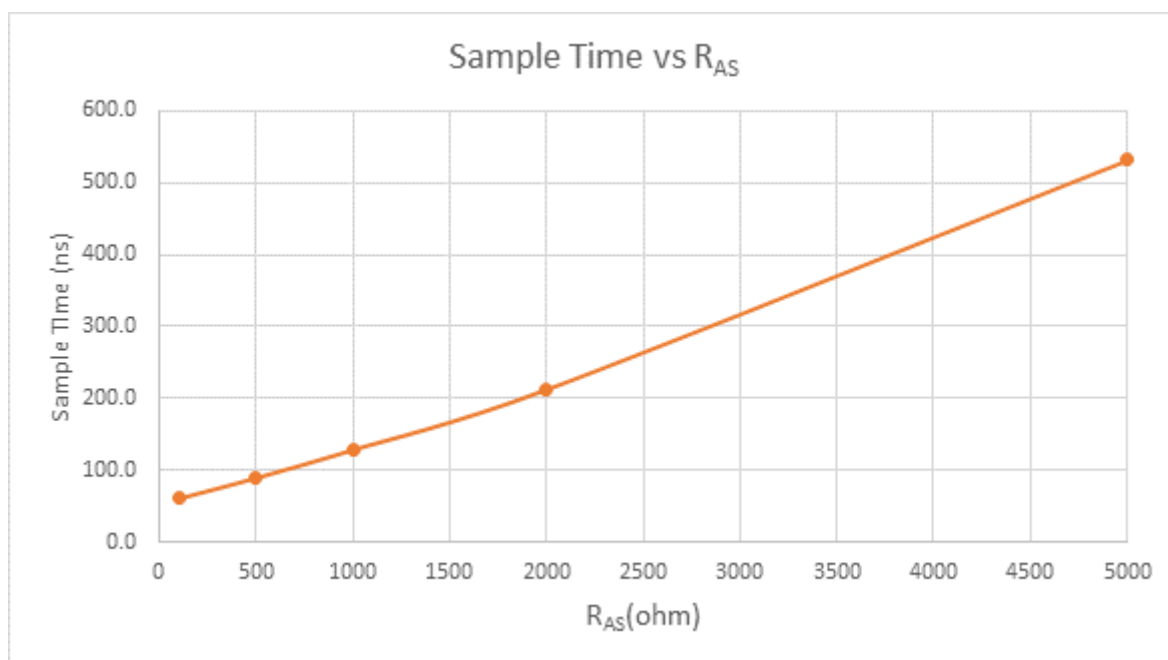

Figure 33. Sample time vs. R_{AS}

9.2.2.1.1 12-bit ADC operating conditions

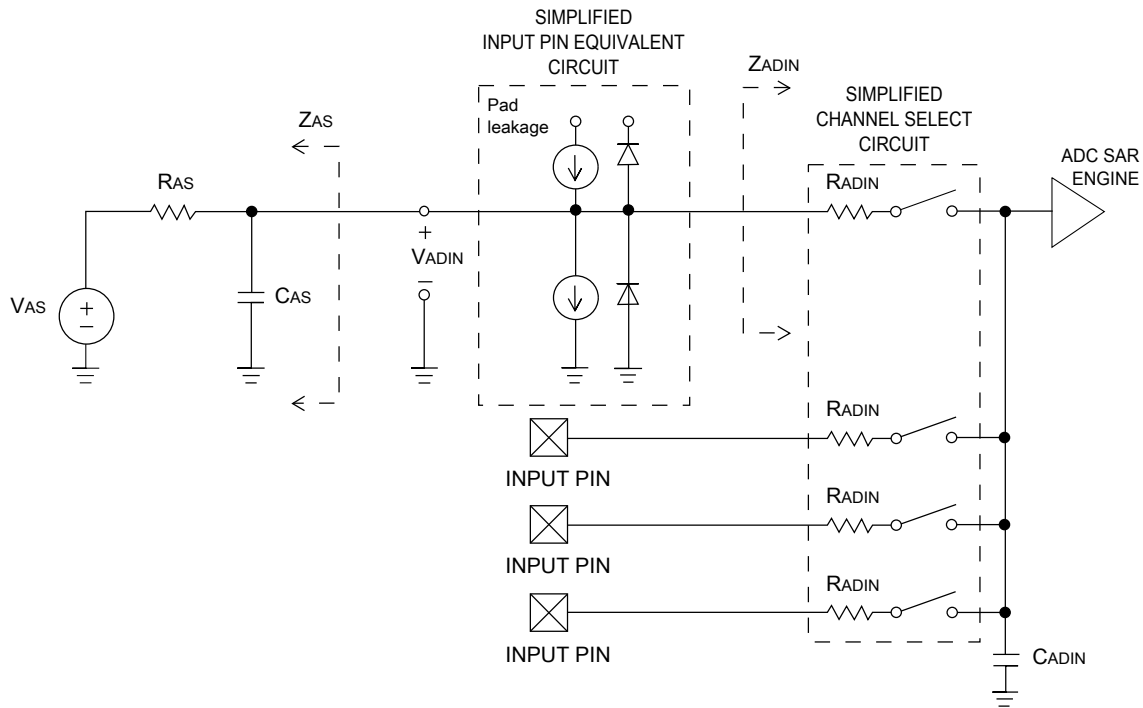

Figure 34. ADC input impedance equivalency diagram

9.2.2.2 12-bit DAC electrical characteristics

9.2.2.2.1 12-bit DAC operating requirements

Table 54. 12-bit DAC operating conditions

Symbol	Description	Min	Typ	Max	Unit	Notes
C_L	Output load capacitance	—	50	100	pF	1
I_L	Output load current	—	—	1	mA	2

1. The DAC output can drive R and C loading. The user should consider both DC and dynamic application requirements. 50pF C_L provides the best dynamic performance, while 100pF provides the best DC performance.
2. Sink or source current ability.

Table 55. DAC characteristics

Symbol	Description	Test Conditions	Min	Typ	Max	Units	Notes
VDACOUTL	DAC low level output voltage	VREFH_ANA18 selected, $R_{load}=18k$, $C_{load}=50pF$	VSS	—	0.15	V	1
VDACOUTH	DAC high level output voltage		VDD_ANA18 -0.15	—	VDD_ ANA18		

Table continues on the next page...

Table 55. DAC characteristics (continued)

Symbol	Description	Test Conditions	Min	Typ	Max	Units	Notes
DNL	Differential non-linearity error	Code 100h → F00h best fit curve	—	±0.5	±1	LSB	—
INL	Integral non-linearity error	Code 100h → F00h best fit curve	—	±1	—		2
			—	±2	—		3
EO	Offset error	Code 100h	—	±0.6	—	%FSR	—
TEO	Offset error temperature coefficient	Code 100h	—	±30	—	µV/°C	—
EG	Gain error	Code F00h	—	±0.4	—	%FSR	—
TEG	Gain error temperature coefficient	Code F00h	—	10	—	ppm of FSR/°C	—
TFS_LS	Full scale setting time in Low Speed mode	Code → F00h or F00h → 100h @ ZTC current	—	5	—	µs	4
		Code 100h → F00h or F00h → 100h @ PTAT current	—	5	—		
TFS_MS	Full scale setting time in Middle Speed mode	Code 100h → F00h or F00h → 100h @ ZTC current	—	1	—		
		Code 100h → F00h or F00h → 100h @ PTAT current	—	1	—		
TFS_HS	Full scale setting time in High Speed mode	Code 100h → F00h or F00h → 100h @ ZTC current	—	0.5	—		
		Code 100h → F00h or F00h → 100h @ PTAT current	—	0.5	—		
TCC_LS	Code to code setting time in Low Speed mode	Code 7F7h → 807h or 807h → 7F7h @ ZTC current	—	1	—		
		Code 7F7h → 807h or 807h → 7F7h @ PTAT current	—	1	—		
TCC_MS	Code to code setting time in Middle Speed mode	Code 7F7h → 807h or 807h → 7F7h @ ZTC current	—	0.5	—		
		Code 7F7h → 807h or 807h → 7F7h @ PTAT current	—	0.5	—		
TCC_HS	Code to code setting time in High Speed mode	Code 7F7h → 807h or 807h → 7F7h @ ZTC current	—	0.3	—		
		Code 7F7h → 807h or 807h → 7F7h @ PTAT current	—	0.3	—		
SR_LS	Slew rate in Low Speed mode	Code 100h → F00h or F00h → 100h @ ZTC current	—	0.24	—	V/µs	5
		Code 100h → F00h or F00h → 100h @ PTAT current	—	0.24	—		
SR_MS	Slew rate in Middle Speed mode	Code 100h → F00h or F00h → 100h @ ZTC current	—	1.2	—		
		Code 100h → F00h or F00h → 100h @ PTAT current	—	1.2	—		
SR_HS	Slew rate in High Speed mode	Code 100h → F00h or F00h → 100h @ ZTC current	—	2.4	—		

Table continues on the next page...

Table 55. DAC characteristics (continued)

Symbol	Description	Test Conditions	Min	Typ	Max	Units	Notes
		Code 100h → F00h or F00h → 100h @ PTAT current	—	2.4	—		
PSRR	Power supply rejection ratio	Code 800h, $\Delta VDD_ANA18=100mV$, VREFH_ANA12 selected	—	70	—	dB	6
Glitch	Glitch energy	Code 100h → F00h → 100h	—	30	—	nV-s	—
		Code 7FFh → 800h → 7FFh	—	30	—		
CT	Channel to channel crosstalk	—	—	—	-80	dB	7
ROP	Output resistance	Code 100h → F00h and Rload=18k Ω	—	200	—	Ω	8

- It is recommended to operate the DAC in the output voltage range between 0.15 V and (VDD_ANA18 - 0.15 V) for best accuracy. Linearity of the output voltage outside this range will be affected as current load increases.
- When VREFH_ANA18 is selected as the reference (DAC_CR[DACRFS]=1b).
- When the internal 1.2 V source is selected as the reference (DAC_CR[DACRFS]=1b).
- The DAC output remains within ± 0.5 LSB of the final measured value for digital input code change. Noise on the power supply can cause this performance to degrade to ± 1 LSB. This parameter represents both rising edge and falling edge settling time.
- Time for the DAC output to transition from 10% to 90% signal amplitude (rising edge or falling edge).
- $PSRR=20*\log\{\Delta VDD_ANA18 / \Delta VDAC_OUT\}$
- If two DACs are used and sharing the same VREFH.
- Based on design simulation.

9.2.2.3 CMP electrical specifications

Table 56. CMP Operating Conditions

Symbol	Description	Min	Typ	Max	Unit
VREFH_EXT	External reference voltage	1	—	1.98	V
VREFH_INT ¹	Internal reference voltage	—	1.3	—	V

- This is an internally generated voltage reference generated by PMC0.

Table 57. CMP Characteristics

Symbol	Description	Condition	Min	Typ	Max	Unit
VAIN	Analog input voltage		0		VDD_PT _x ¹	V
VAIO	Analog input offset voltage				20	mV
VH	Analog comparator hysteresis	Hysctrl[1:0]=00		5		mV
		Hysctrl[1:0]=01		10		mV
		Hysctrl[1:0]=10		20		mV
		Hysctrl[1:0]=11		30		mV

Table continues on the next page...

Table 57. CMP Characteristics (continued)

Symbol	Description	Condition	Min	Typ	Max	Unit
TDHS	Propagation delay, high-speed mode	Nominal supply			50	ns
TDHS	Propagation delay, low-speed mode				5	μs
	Analog comparator initialization delay				20	μs
INL	8B DAC integral non-linearity		-1		1	LSB
DNL	8B DAC differential non-linearity		-1		1	LSB

1. The maximum input voltage for CMP analog inputs associated with Port A (PTA) is VDD_PTA. The maximum input voltage for CMP analog inputs associated with Port B (PTB) is VDD_PTB.

9.2.3 Timer specifications—real-time domain

See [General switching timing specifications](#).

9.2.4 Connectivity and communications specifications—real-time domain

9.2.4.1 LPUART

See [General switching timing specifications](#).

9.2.4.2 Inter-Integrated Circuit Interface (I²C) timing—real-time domain

See [Inter-Integrated Circuit Interface \(I²C\) timing](#).

9.2.4.3 LPSPI switching specifications—real-time domain

See [Low Power Serial Peripheral Interface \(LPSPI\) switching specifications—application domain](#).

9.2.4.4 I2S/SAI switching specifications

This section provides the AC timing for the I2S/SAI module in master mode (clocks are driven) and slave mode (clocks are input). All timing is given for noninverted serial clock polarity (TCR2[BCP] is 0, RCR2[BCP] is 0) and a noninverted frame sync

(TCR4[FSP] is 0, RCR4[FSP] is 0). If the polarity of the clock and/or the frame sync have been inverted, all the timing remains valid by inverting the bit clock signal (BCLK) and/or the frame sync (FS) signal shown in the following figures.

Table 58. I2S/SAI master mode timing

Num.	Parameter	Min	Max	Unit
S1	I2S_MCLK cycle time	20	—	ns
S2	I2S_MCLK (as an input) pulse width high/low	45%	55%	MCLK period
S3	I2S_TX_BCLK/I2S_RX_BCLK cycle time (output)	40	—	ns
S4	I2S_TX_BCLK/I2S_RX_BCLK pulse width high/low	45%	55%	BCLK period
S5	I2S_TX_BCLK/I2S_RX_BCLK to I2S_TX_FS/I2S_RX_FS output valid	—	7.5	ns
S6	I2S_TX_BCLK/I2S_RX_BCLK to I2S_TX_FS/I2S_RX_FS output invalid	0	—	ns
S7	I2S_TX_BCLK to I2S_TXD valid	—	15.9	ns
S8	I2S_TX_BCLK to I2S_TXD invalid	1	—	ns
S9	I2S_RXD/I2S_RX_FS input setup before I2S_RX_BCLK	21.3	—	ns
S10	I2S_RXD/I2S_RX_FS input hold after I2S_RX_BCLK	0	—	ns

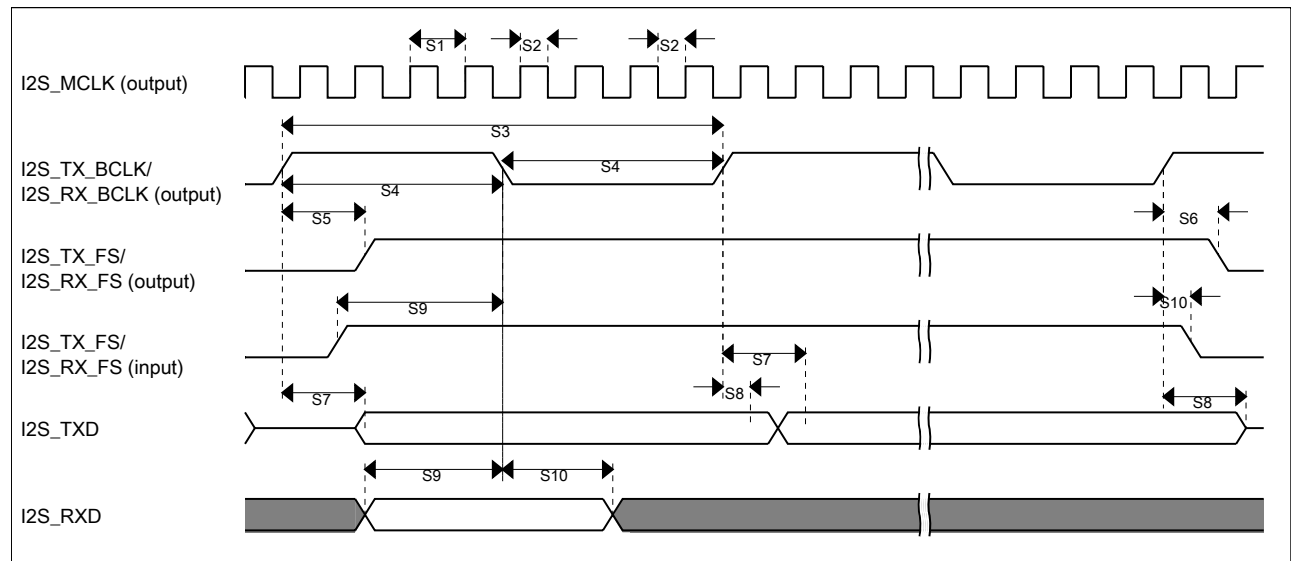

Figure 35. I2S/SAI timing — master modes

Table 59. I2S/SAI slave mode timing

Num.	Parameter	Min	Max	Unit
S11	I2S_TX_BCLK/I2S_RX_BCLK cycle time (input)	40	—	ns
S12	I2S_TX_BCLK/I2S_RX_BCLK pulse width high/low (input)	45%	55%	MCLK period

Table continues on the next page...

Table 59. I2S/SAI slave mode timing (continued)

Num.	Parameter	Min	Max	Unit
S13	I2S_TX_FS/I2S_RX_FS input setup before I2S_TX_BCLK/ I2S_RX_BCLK	13	—	ns
S14	I2S_TX_FS/I2S_RX_FS input hold after I2S_TX_BCLK/ I2S_RX_BCLK	1	—	ns
S15	I2S_TX_BCLK to I2S_TXD/I2S_TX_FS output valid	—	22.8	ns
S16	I2S_TX_BCLK to I2S_TXD/I2S_TX_FS output invalid	1	—	ns
S17	I2S_RXD setup before I2S_RX_BCLK	12	—	ns
S18	I2S_RXD hold after I2S_RX_BCLK	1	—	ns
S19	I2S_TX_FS input assertion to I2S_TXD output valid ¹	—	17.0	ns

1. Applies to first bit in each frame and only if the TCR4[FSE] bit is clear

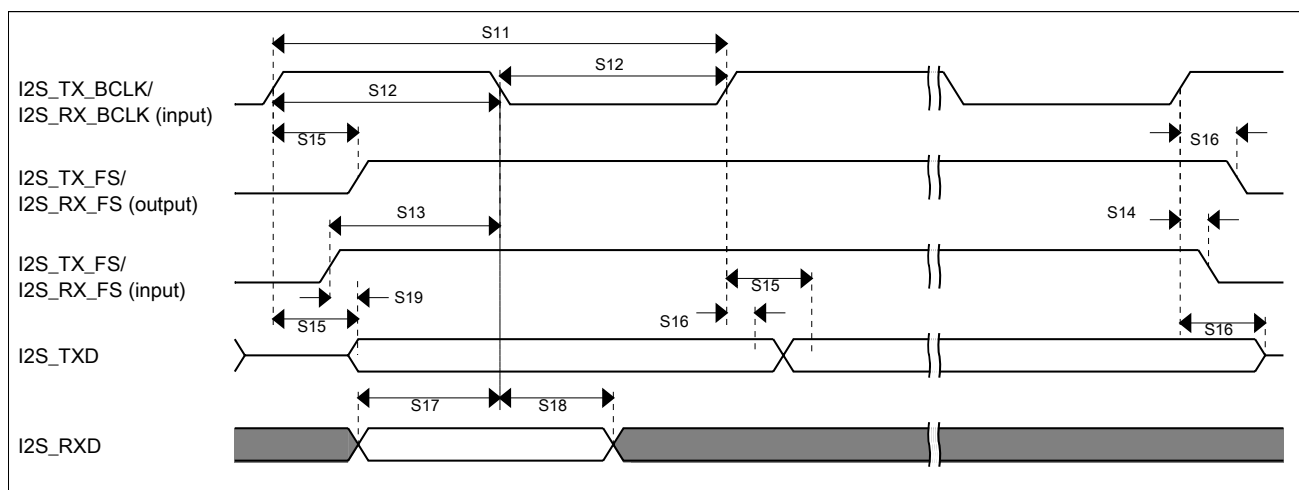

Figure 36. I2S/SAI timing — slave modes

9.2.4.5 VLPR, VLPW, and VLPS mode performance

This section provides the operating performance for the device in VLPR, VLPW, and VLPS modes.

Table 60. I2S/SAI master mode timing in VLPR, VLPW, and VLPS modes

Num.	Parameter	Min	Max	Unit
S1	I2S_MCLK cycle time	60	—	ns
S2	I2S_MCLK pulse width high/low	45%	55%	MCLK period
S3	I2S_TX_BCLK/I2S_RX_BCLK cycle time (output)	100	—	ns
S4	I2S_TX_BCLK/I2S_RX_BCLK pulse width high/low	45%	55%	BCLK period
S5	I2S_TX_BCLK/I2S_RX_BCLK to I2S_TX_FS/I2S_RX_FS output valid	—	15	ns

Table continues on the next page...

Table 60. I2S/SAI master mode timing in VLPR, VLPW, and VLPS modes (continued)

Num.	Parameter	Min	Max	Unit
S6	I2S_TX_BCLK/I2S_RX_BCLK to I2S_TX_FS/I2S_RX_FS output invalid	0	—	ns
S7	I2S_TX_BCLK to I2S_TXD valid	—	25	ns
S8	I2S_TX_BCLK to I2S_TXD invalid	0	—	ns
S9	I2S_RXD/I2S_RX_FS input setup before I2S_RX_BCLK	25	—	ns
S10	I2S_RXD/I2S_RX_FS input hold after I2S_RX_BCLK	0	—	ns

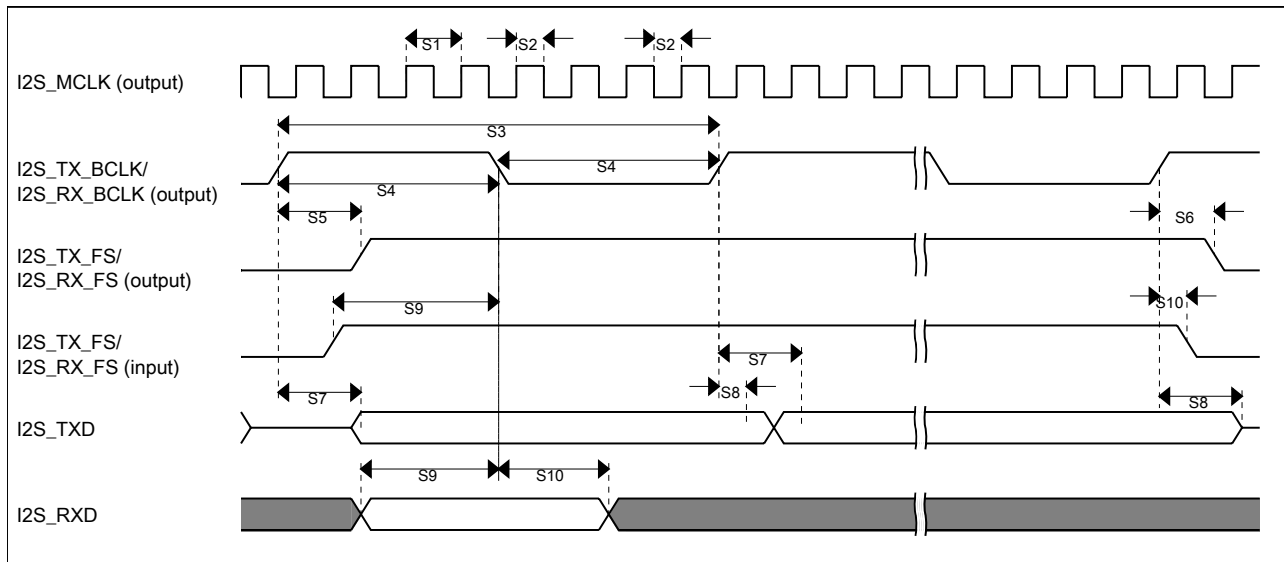

Figure 37. I2S/SAI timing — master modes

Table 61. I2S/SAI slave mode timing in VLPR, VLPW, and VLPS modes

Num.	Parameter	Min	Max	Unit
S11	I2S_TX_BCLK/I2S_RX_BCLK cycle time (input)	100	—	ns
S12	I2S_TX_BCLK/I2S_RX_BCLK pulse width high/low (input)	45%	55%	MCLK period
S13	I2S_TX_FS/I2S_RX_FS input setup before I2S_TX_BCLK/I2S_RX_BCLK	30	—	ns
S14	I2S_TX_FS/I2S_RX_FS input hold after I2S_TX_BCLK/I2S_RX_BCLK	2	—	ns
S15	I2S_TX_BCLK to I2S_TXD/I2S_TX_FS output valid	—	40	ns
S16	I2S_TX_BCLK to I2S_TXD/I2S_TX_FS output invalid	1	—	ns
S17	I2S_RXD setup before I2S_RX_BCLK	30	—	ns
S18	I2S_RXD hold after I2S_RX_BCLK	5	—	ns
S19	I2S_TX_FS input assertion to I2S_TXD output valid ¹	—	27	ns

1. Applies to first bit in each frame and only if the TCR4[FSE] bit is clear

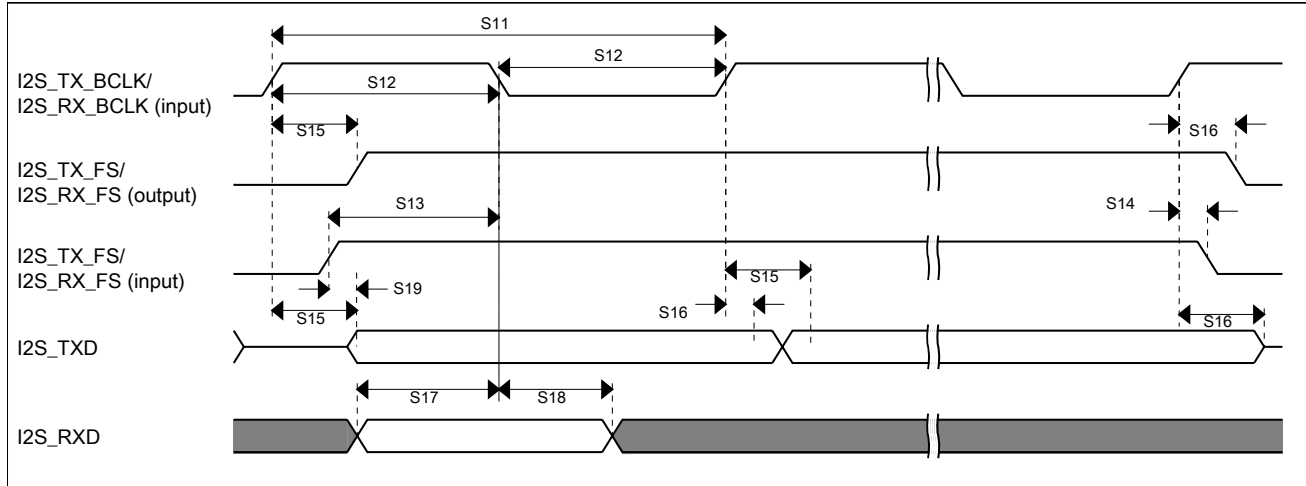

Figure 38. I2S/SAI timing — slave modes

9.2.4.6 FlexIO specifications—real-time domain

See [General switching timing specifications](#)

10 Package information and contact assignments

This section contains package information and contact assignments for the following packages:

- BGA 14 x 14 mm, 0.5 mm pitch (VP suffix)

10.1 BGA, 14 x 14 mm, 0.5 mm pitch (VP suffix)

This section includes the following information for the 14 x 14 mm, 0.5 mm pitch package:

- Case outline
- Ball map
- Contact assignments

10.1.1 14 x 14 mm package case outline

The following figure shows the top, bottom, and side views of the 14 x 14 mm BGA package.

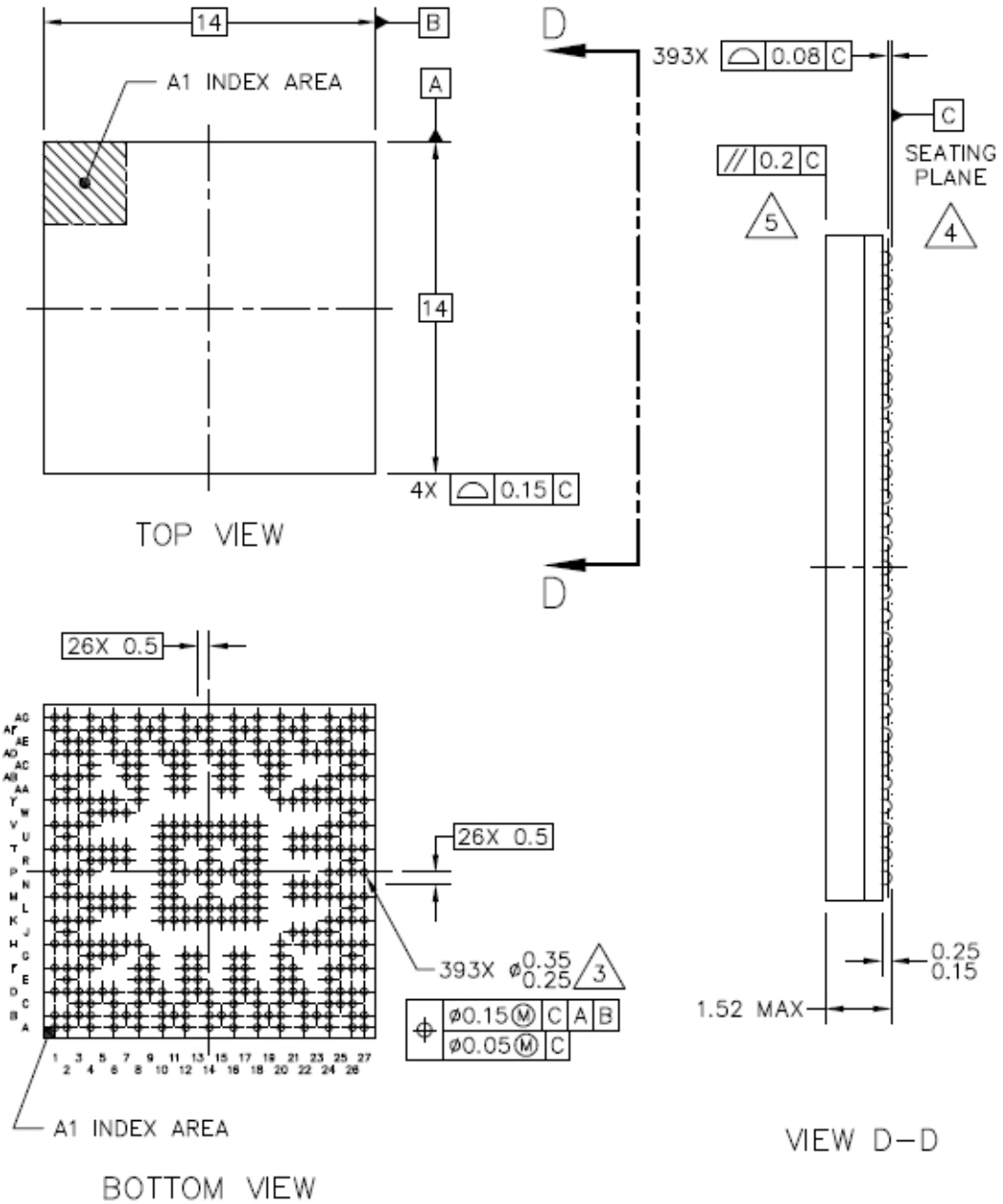

© NXP SEMICONDUCTORS N.V. ALL RIGHTS RESERVED	MECHANICAL OUTLINE	PRINT VERSION NOT TO SCALE
TITLE: MAPBGA, 14 X 14 X 1.38 PKG, 0.5 MM PITCH, 393 I/O	DOCUMENT NO: 98ASA01091D	REV: 0
	STANDARD: JEDEC MO-275	
	SOT1879-2	16 JUN 2017

Figure 39. 14 x 14 mm case outline

Package information and contact assignments

NOTES:

1. ALL DIMENSIONS IN MILLIMETERS.
2. DIMENSIONING AND TOLERANCING PER ASME Y14.5M—1994.
3. MAXIMUM SOLDER BALL DIAMETER MEASURED PARALLEL TO DATUM C.
4. DATUM C, THE SEATING PLANE, IS DETERMINED BY THE SPHERICAL CROWNS OF THE SOLDER BALLS.
5. PARALLELISM MEASUREMENT SHALL EXCLUDE ANY EFFECT OF MARK ON TOP SURFACE OF PACKAGE.

© NXP SEMICONDUCTORS N.V. ALL RIGHTS RESERVED	MECHANICAL OUTLINE	PRINT VERSION NOT TO SCALE	
TITLE: M1PBG1, 14 X 14 X 1.38 PKG, 0.5 MM PITCH, 393 I/O		DOCUMENT NO: 98ASA01091D	REV: 0
		STANDARD: JEDEC MO-275	
		SOT1879-2	16 JUN 2017

Figure 40. Notes on 14 x 14 mm case outline

10.1.2 14 x 14 mm, 0.5 mm pitch, ball map

The following page shows the 14 × 14 mm, 0.5 mm pitch, ball map.

14 x 14 mm, 0.5 mm pitch, ballmap

	1	2	3	4	5	6	7	8	9	10	11	12	13	14	15	16	17	18	19	20	21	22	23	24	25	26	27		
A	VSS	PTF6		VDD18_HSIC		PTE15		PTE11		PTE5		PTE1		PTC12		PTC8		PTD11		PTD7		PTD4		PTD0		DDR_DQ16	VSS	A	
B	PTF5	PTF1	PTF2	VSS		PTE14	PTE13	PTE12		PTE4	PTE3	PTE2		PTC11	PTC10	PTC9		PTD10	PTD9	PTD8		PTD3	PTD2	PTD1		DDR_DQ18	DDR_DQ17	B	
C			PTF3	VSS		VSS		VSS		VSS		VSS		VSS		VSS		VSS		VSS		VSS		VSS	VSS	DDR_DQ19		C	
D	PTF9	PTF0	VSS	HSIC_DATA	HSIC_STROBE	VDD_HSIC		PTE10	PTE6	VDD_PTE		PTE0	PTC13	VDD_PTC		PTC6	PTC5	PTC0		VDD_PTD	PTD5	PTD6		DDR_DQ22	VSS	DDR_DQ20	DDR_DQ21	D	
E		PTF4						PTE7	VDD_PTE			PTC19	PTC14		VDD_PTC	PTC1			VDD_PTD	VSS				DDR_DQ23				E	
F	PTF8	PTF7	VSS	VDD_PTF				VSS	PTE8			PTC18	PTC15			PTC4	PTC2			VSS	VSS			VDD18_DDR	VSS	DDR_DQS2_B	DDR_DQS2	F	
G				VDD_PTF	PTF10	PTF11			PTE9			PTC17	PTC16			PTC7	PTC3			VSS					DDR_DQM2			G	
H	PTF16	PTF17	VSS	PTF15	PTF14	PTF13	PTF12	VSS												VSS		VDD_DDR	DDR_VREF0	DDR_DQ2	VSS	DDR_DQ0	DDR_DQ1	H	
J		PTF18																			VDD_DDR	DDR_CA4	DDR_CA3	DDR_DQ3				J	
K	RESET1_B	PTF19	VSS	VSS						VSS	VDD_DIG1	VDD_DIG1	VDD_DIG1	VSS	VDD_DIG1	VDD_DIG1	VDD_DIG1	VSS						DDR_DQ4	VSS	DDR_DQ6	DDR_DQ5	K	
L				DSI_DATA1_N	VSS	VDD_DS11	VDD18_IOREF				VDD_DIG1	VSS	VSS	VSS	VDD_DIG1	VSS	VSS	VSS	VDD_DIG1						DDR_DQ7			L	
M	DSI_CLK_P	DSI_CLK_N	VSS	DSI_DATA1_P	VDD_DS18	VSS	VSS				VDD_DIG1	VSS		VSS			VSS	VDD_DIG1			VSS	VDD_DDR	DDR_CA2	DDR_DQM0	VSS	DDR_DQ50	DDR_DQ50_B	M	
N		VSS									VDD_DIG1	VSS		VSS			VSS	VDD_DIG1			VDD_DDR	DDR_CA1	DDR_CA0	DDR_CS1_B				N	
P	DSI_DATA0_P	DSI_DATA0_N	VSS	VSS						VSS	VDD_DIG1	VSS	VSS	VSS	VSS	VSS	VDD_DIG1	VSS						DDR_CKE1	VSS	DDR_CKE0	DDR_CS0_B	P	
R				VSS	VDD_USB33	VSS	VDD_USB18				VDD_DIG1	VSS		VSS			VSS	VDD_DIG1							DDR_CLK0			R	
T	USB0_DP	USB0_DM	VSS	USB0_VBUS_DETECT	VDD_VBAT42	VDD_VBAT18_CAP	VSS			VDD_PMC11_DIG1_CAP	VSS		VSS		VSS	VSS	VDD_DIG1			VDD_DDR	DDR_CA6	DDR_CAS	DDR_DQS1_B	VSS	DDR_CLK0_B	DDR_DQM1	T		
U		VSS								VDD_PMC11_DIG1_CAP	VSS	VSS	VSS	VDD_PMC11_DIG0_CAP	VSS	VSS	VSS	VDD_DIG1			VSS	VDD_DDR	DDR_CA7	DDR_DQS1				U	
V	PMIC_ON_REQ	STANDBY_REQ	VSS_ANA	TAMPER						VSS	VDD_PMC18_DIG0	VDD_PMC18_DIG0	VDD_PMC18_DIG0	VSS	VDD_PMC11_DIG0_CAP	VDD_DIG0	VDD_DIG0	VSS						DDR_DQ8	VSS	DDR_DQ10	DDR_DQ9	V	
W				EXTAL32	VSS	VSS	VDD_PLL18																			DDR_DQ11			W
Y	VSS	ONOFF	VSS	XTAL32	VSS	VSS															VSS	VDD_DDR	DDR_CA9	DDR_VREF1	DDR_DQ15	DDR_DQ14	DDR_DQ12	DDR_DQ13	Y
AA		XTAL0								VDD_PTB	VDD_ANA33			VDD_PTA	VSS			VDD_PTA				DDR_ODT	DDR_CA8	DDR_DQM3				AA	
AB	VSS	EXTAL0	VDD_PMC18	VDD_PMC12_DIG1				PTB11	TESTCLK_P		VDD_ANA18	VREF1_ANA		PTA6	PTA8			PTA19	PTA21					VSS	VSS	DDR_DQ53	DDR_DQ53_B	AB	
AC				VDD_PMC12_DIG1				PTB10	PTB12		RESET0_b	VREFH_ANA18		PTA5	PTA9			PTA18	PTA22							DDR_DQ24		AC	
AD	VSS	VSS	VSS	VSS		VDD_PTB	PTB9	PTB13		PTB19	DAC0_OUT	VSS_ADC_ANA		PTA7	PTA4	PTA10		PTA11	PTA17	PTA23			PTA20	PTA29	PTA30	VSS	DDR_DQ27	DDR_DQ26	AD
AE		VSS	PTB2	PTB3		VSS		VSS		VSS			DAC1_OUT		PTA0		VSS	VSS		VSS		VSS		VSS		DDR_DQ30		AE	
AF	VSS	PTB1		PTB5	PTB6	PTB7		PTB15	PTB16	PTB17		VSS_ADC_ANA	PTA1	PTA3		PTA13	PTA14	PTA15			PTA24	PTA26	PTA27		PTA31	DDR_DQ31	DDR_DQ25	DDR_DQ28	AF
AG	VSS	PTB0		PTB4		PTB8		PTB14		PTB18		VSS_ADC_ANA		PTA2		PTA12		PTA16			PTA25		PTA28		DDR_ZQ0		DDR_DQ29	VSS	AG
	1	2	3	4	5	6	7	8	9	10	11	12	13	14	15	16	17	18	19	20	21	22	23	24	25	26	27		

10.1.3 14 x 14 mm power supply and functional contact assignments

The following table shows the power supply contact assignments for the 14 × 14 mm package.

Table 62. 14 x 14 mm power supply contact assignments

Supply Name	14x14 mm VP Package Ball Position	Remarks
DDR_ODT	AA22	DDR on-die termination
DDR_VREF0	H23	DDR voltage reference input. Connect to a voltage source that is 50% of VDD_DDR.
DDR_VREF1	Y23	DDR voltage reference input. Connect to a voltage source that is 50% of VDD_DDR.
DDR_ZQ0	AG24	Connect DDR_ZQ0 to an external 240Ω 1% resistor to Vss. This is a reference used during DDR output buffer driver calibration.
TESTCLK_N	AA8	Test function for NXP use only. This output must remain unconnected.
TESTCLK_P	AB8	Test function for NXP use only. This output must remain unconnected.
USB0_VBUS	T4	USB0 VBUS detection
VDD_ANA18	AB11	ADC analog and IO 1.8V supply input
VDD_ANA33	AA12	ADC analog and IO 3.3V supply input
VDD_DDR	H22, J21, M22, N21, T21, U22, Y21	DDR I/O supply input
VDD_DIG0	V16, V17	M4 domain core and logic supply input
VDD_DIG1	K11, K12, K13, K15, K16, K17, L10, L14, L18, M10, M18, N10, N18, P11, P17, R10, R18, T18, U18	A7 domain core and logic supply input
VDD_DSI11	L6	MIPI DSI 1.1V supply input
VDD_DSI18	M5	MIPI DSI 1.8V supply input
VDD_HSIC	D6	HSIC 1.2V supply input
VDD_PLL18	W7	PLL analog supply input
VDD_PMC11_DIG0_CAP	U14, V15	M4 domain LDO supply output
VDD_PMC11_DIG1_CAP	T10, U10	A7 domain LDO supply output
VDD_PMC12_DIG1	AB4, AC4	A7 domain LDO and internal memory LDO supply input
VDD_PMC18	AB3	M4/A7 PMC and PMC IO supply input
VDD_PMC18_DIG0	V11, V12, V13	M4 domain LDO and internal memory LDO supply input
VDD_PTA	AA15, AA19	GPIO Port A supply input
VDD_PTB	AA11, AD6	GPIO Port B supply input

Table continues on the next page...

Table 62. 14 x 14 mm power supply contact assignments (continued)

Supply Name	14x14 mm VP Package Ball Position	Remarks
VDD_PTC	D14, E16	GPIO Port C supply input
VDD_PTD	D20, E20	GPIO Port D supply input
VDD_PTE	D10, E9	GPIO Port E supply input
VDD_PTF	F4, G4	GPIO Port F supply input
VDD_USB18	R7	USB PHY 1.8V supply input
VDD_USB33	R5	USB PHY 3.3V supply input
VDD_VBAT18_CAP	T6	SNVS domain LDO output
VDD_VBAT42	T5	SNVS domain LDO supply input
VDD18_DDR	F24	DDR 1.8V pre-driver supply input
VDD18_HSIC	A4	HSIC 1.8V supply input
VDD18_IOREF	L7	1.8V IO supply reference and A7 supply reference input
VREFH_ANA18	AC12	ADC high reference supply input
VREFL_ANA	AB12	ADC low reference supply input
VSS	A1, A27, B4, C4, C6, C8, C10, C12, C14, C16, C18, C20, C22, C24, C25, D3, D25, E21, F3, F8, F20, F21, F25, G20, H3, H8, H20, H25, K3, K4, K10, K14, K18, K25L5, L11, L12, L13, L15, L16, L17, M3, M6, M7, M11, M14, M17, M21, M25, N2, N11, N14, N17, P3, P4, P10, P12, P13, P14, P15, P16, P18, P25, R4, R7, R11, R14, R17, T3, T7, T11, T4, T17, T25, U2, U11, U12, U13, U15, U16, U17, U21, V3, V10, V14, V18, V25, W5, W6, Y1, Y3, Y5, Y6, Y20, AA16, AB1, AB24, AB25, AD1, AD2, AD3, AD4, AD25, AE2, AE6, AE8, AE10, AE16, AE18, AE20, AE22, AE24, AF1, AG1, AG27	Ground
VSS_ADC_ANA	AD12, AF12, AG12	ADC analog ground

The following table shows functional contact assignments for the 14 x 14 mm package.

Table 63. 14 x 14 mm functional contact assignments

Ball Name	14 x 14 mm VP Package Ball Position	Power Group	Signal Type ^{1, 2}	Default MUX_MODE ¹	Default Function ¹	State During Reset ³	State After Reset ^{1, 3}
DAC0_OUT	AD11	VDD_ANA18	Analog	-	DAC0_OUT	-	-

Table continues on the next page...

Table 63. 14 x 14 mm functional contact assignments (continued)

Ball Name	14 x 14 mm VP Package Ball Position	Power Group	Signal Type ^{1,2}	Default MUX_MODE ¹	Default Function ¹	State During Reset ³	State After Reset ^{1,3}
DAC1_OUT	AD12	VDD_ANA18	Analog	-	DAC1_OUT	-	-
DDR_CA0	N23	VDD_DDR	DDR	-	DDR_CA0	Output/PD	Output/PD
DDR_CA1	N22	VDD_DDR	DDR	-	DDR_CA1	Output/PD	Output/PD
DDR_CA2	M23	VDD_DDR	DDR	-	DDR_CA2	Output/PD	Output/PD
DDR_CA3	J23	VDD_DDR	DDR	-	DDR_CA3	Output/PD	Output/PD
DDR_CA4	J22	VDD_DDR	DDR	-	DDR_CA4	Output/PD	Output/PD
DDR_CA5	T23	VDD_DDR	DDR	-	DDR_CA5	Output/PD	Output/PD
DDR_CA6	T22	VDD_DDR	DDR	-	DDR_CA6	Output/PD	Output/PD
DDR_CA7	U23	VDD_DDR	DDR	-	DDR_CA7	Output/PD	Output/PD
DDR_CA8	AA23	VDD_DDR	DDR	-	DDR_CA8	Output/PD	Output/PD
DDR_CA9	Y22	VDD_DDR	DDR	-	DDR_CA9	Output/PD	Output/PD
DDR_CKE0	P26	VDD_DDR	DDR	-	DDR_CKE0	Output/PD	Output/PD
DDR_CKE1	P24	VDD_DDR	DDR	-	DDR_CKE1	Output/PD	Output/PD
DDR_CLK0	R26	VDD_DDR	DDR	-	DDR_CLK0	Output	Output
DDR_CLK0_B	T26	VDD_DDR	DDR	-	DDR_CLK0_B	Output	Output
DDR_CS0_B	P27	VDD_DDR	DDR	-	DDR_CS0_B	Output/PD	Output/PD
DDR_CS1_B	N24	VDD_DDR	DDR	-	DDR_CS1_B	Output/PD	Output/PD
DDR_DQ0	H26	VDD_DDR	DDR	-	DDR_DQ0	PD	PD
DDR_DQ1	H27	VDD_DDR	DDR	-	DDR_DQ1	PD	PD
DDR_DQ10	V26	VDD_DDR	DDR	-	DDR_DQ10	PD	PD
DDR_DQ11	W26	VDD_DDR	DDR	-	DDR_DQ11	PD	PD
DDR_DQ12	Y26	VDD_DDR	DDR	-	DDR_DQ12	PD	PD
DDR_DQ13	Y27	VDD_DDR	DDR	-	DDR_DQ13	PD	PD
DDR_DQ14	Y25	VDD_DDR	DDR	-	DDR_DQ14	PD	PD
DDR_DQ15	Y24	VDD_DDR	DDR	-	DDR_DQ15	PD	PD
DDR_DQ16	A26	VDD_DDR	DDR	-	DDR_DQ16	PD	PD
DDR_DQ17	B27	VDD_DDR	DDR	-	DDR_DQ17	PD	PD
DDR_DQ18	B26	VDD_DDR	DDR	-	DDR_DQ18	PD	PD
DDR_DQ19	C26	VDD_DDR	DDR	-	DDR_DQ19	PD	PD
DDR_DQ2	H24	VDD_DDR	DDR	-	DDR_DQ2	PD	PD
DDR_DQ20	D26	VDD_DDR	DDR	-	DDR_DQ20	PD	PD
DDR_DQ21	D27	VDD_DDR	DDR	-	DDR_DQ21	PD	PD
DDR_DQ22	D24	VDD_DDR	DDR	-	DDR_DQ22	PD	PD
DDR_DQ23	E24	VDD_DDR	DDR	-	DDR_DQ23	PD	PD
DDR_DQ24	AC26	VDD_DDR	DDR	-	DDR_DQ24	PD	PD
DDR_DQ25	AF26	VDD_DDR	DDR	-	DDR_DQ25	PD	PD

Table continues on the next page...

Table 63. 14 x 14 mm functional contact assignments (continued)

Ball Name	14 x 14 mm VP Package Ball Position	Power Group	Signal Type ^{1, 2}	Default MUX_MODE ¹	Default Function ¹	State During Reset ³	State After Reset ^{1, 3}
DDR_DQ26	AD27	VDD_DDR	DDR	-	DDR_DQ26	PD	PD
DDR_DQ27	AD26	VDD_DDR	DDR	-	DDR_DQ27	PD	PD
DDR_DQ28	AF27	VDD_DDR	DDR	-	DDR_DQ28	PD	PD
DDR_DQ29	AG26	VDD_DDR	DDR	-	DDR_DQ29	PD	PD
DDR_DQ3	J24	VDD_DDR	DDR	-	DDR_DQ3	PD	PD
DDR_DQ30	AE25	VDD_DDR	DDR	-	DDR_DQ30	PD	PD
DDR_DQ31	AF25	VDD_DDR	DDR	-	DDR_DQ31	PD	PD
DDR_DQ4	K24	VDD_DDR	DDR	-	DDR_DQ4	PD	PD
DDR_DQ5	K27	VDD_DDR	DDR	-	DDR_DQ5	PD	PD
DDR_DQ6	K26	VDD_DDR	DDR	-	DDR_DQ6	PD	PD
DDR_DQ7	L26	VDD_DDR	DDR	-	DDR_DQ7	PD	PD
DDR_DQ8	V24	VDD_DDR	DDR	-	DDR_DQ8	PD	PD
DDR_DQ9	V27	VDD_DDR	DDR	-	DDR_DQ9	PD	PD
DDR_DQM0	M24	VDD_DDR	DDR	-	DDR_DQM0	Output/PD	Output/PD
DDR_DQM1	T27	VDD_DDR	DDR	-	DDR_DQM1	Output/PD	Output/PD
DDR_DQM2	G26	VDD_DDR	DDR	-	DDR_DQM2	Output/PD	Output/PD
DDR_DQM3	AA24	VDD_DDR	DDR	-	DDR_DQM3	Output/PD	Output/PD
DDR_DQS0	M26	VDD_DDR	DDR	-	DDR_DQS0	Hi-Z	Hi-Z
DDR_DQS0_B	M27	VDD_DDR	DDR	-	DDR_DQS0_B	Hi-Z	Hi-Z
DDR_DQS1	U24	VDD_DDR	DDR	-	DDR_DQS1	Hi-Z	Hi-Z
DDR_DQS1_B	T24	VDD_DDR	DDR	-	DDR_DQS1_B	Hi-Z	Hi-Z
DDR_DQS2	F27	VDD_DDR	DDR	-	DDR_DQS2	Hi-Z	Hi-Z
DDR_DQS2_B	F26	VDD_DDR	DDR	-	DDR_DQS2_B	Hi-Z	Hi-Z
DDR_DQS3	AB26	VDD_DDR	DDR	-	DDR_DQS3	Hi-Z	Hi-Z
DDR_DQS3_B	AB27	VDD_DDR	DDR	-	DDR_DQS3_B	Hi-Z	Hi-Z
DSI_CLK_N	M2	VDD_DSI18	MIPI DSI PHY	-	DSI_CLK_N	-	-
DSI_CLK_P	M1	VDD_DSI18	MIPI DSI PHY	-	DSI_CLK_P	-	-
DSI_DATA0_N	P2	VDD_DSI18	MIPI DSI PHY	-	DSI_DATA0_N	-	-
DSI_DATA0_P	P1	VDD_DSI18	MIPI DSI PHY	-	DSI_DATA0_P	-	-
DSI_DATA1_N	L4	VDD_DSI18	MIPI DSI PHY	-	DSI_DATA1_N	-	-
DSI_DATA1_P	M4	VDD_DSI18	MIPI DSI PHY	-	DSI_DATA1_P	-	-
EXTAL	AB2	VDD_PMC18	Analog	-	EXTAL	-	-

Table continues on the next page...

Table 63. 14 x 14 mm functional contact assignments (continued)

Ball Name	14 x 14 mm VP Package Ball Position	Power Group	Signal Type ^{1,2}	Default MUX_MODE ¹	Default Function ¹	State During Reset ³	State After Reset ^{1,3}
EXTAL32	W4	VDD_VBAT18_CAP	Analog	-	EXTAL32	-	-
HSIC_DATA	D4	VDD_HSIC	DDR	-	HSIC_DATA	Input/PD	Input/PD
HSIC_STROBE	D5	VDD_HSIC	DDR	-	HSIC_STROBE	Input/PD	Input/PD
ONOFF	Y2	VDD_VBAT18_CAP	SNVS	-	ONOFF	Input/PU	Input/PU
PMIC_ON_REQ	V1	VDD_VBAT18_CAP	SNVS	-	PMIC_ON_REQ	Output/High	Output/High
PTA0	AE14	VDD_PTA	FSGPIO	0000b	CMP0_IN1_3V	Input	Hi-Z
PTA1	AF13	VDD_PTA	FSGPIO	0000b	CMP0_IN2_3V	Input	Hi-Z
PTA2	AG14	VDD_PTA	FSGPIO	0000b	CMP1_IN2_3V	Input	Hi-Z
PTA3	AF14	VDD_PTA	FSGPIO	0000b	CMP1_IN4_3V	Input	Hi-Z
PTA4	AD15	VDD_PTA	FSGPIO	0000b	ADC1_CH3A	Input	Hi-Z
PTA5	AC15	VDD_PTA	FSGPIO	0000b	ADC1_CH3B	Input	Hi-Z
PTA6	AB15	VDD_PTA	FSGPIO	0000b	ADC1_CH4A/5A/6A/7A/8A	Input	Hi-Z
PTA7	AD14	VDD_PTA	FSGPIO	0000b	ADC1_CH4B/5B/6B/7B/8B	Input	Hi-Z
PTA8	AB16	VDD_PTA	FSGPIO	0000b	ADC1_CH4A/5A/6A/7A/8A	Input	Hi-Z
PTA9	AC16	VDD_PTA	FSGPIO	0000b	ADC1_CH4B/5B/6B/7B/8B	Input	Hi-Z
PTA10	AD16	VDD_PTA	FSGPIO	0000b	ADC1_CH4A/5A/6A/7A/8A	Input	Hi-Z
PTA11	AD18	VDD_PTA	FSGPIO	0000b	ADC1_CH4B/5B/6B/7B/8B	Input	Hi-Z
PTA12	AG16	VDD_PTA	FSGPIO	0000b	ADC1_CH4A/5A/6A/7A/8A	Input	Hi-Z
PTA13	AF16	VDD_PTA	FSGPIO	0000b	ADC1_CH4B/5B/6B/7B/8B	Input	Hi-Z
PTA14	AF17	VDD_PTA	FSGPIO	0000b	ADC1_CH4A/5A/6A/7A/8A	Input	Hi-Z
PTA15	AF18	VDD_PTA	FSGPIO	0000b	ADC1_CH4B/5B/6B/7B/8B	Input	Hi-Z
PTA16	AG18	VDD_PTA	FSGPIO	0000b	CMP1_IN5_3V	Hi-Z	Hi-Z
PTA17	AD19	VDD_PTA	FSGPIO	0000b	CMP1_IN6_3V	Hi-Z	Hi-Z
PTA18	AC19	VDD_PTA	FSGPIO	0000b	CMP1_IN1_3V	Hi-Z	Hi-Z
PTA19	AB19	VDD_PTA	FSGPIO	0000b	CMP1_IN3_3V	Hi-Z	Hi-Z
PTA20	AD22	VDD_PTA	FSGPIO	0000b	ADC0_CH8A/9A/10A	Hi-Z	Hi-Z

Table continues on the next page...

Table 63. 14 x 14 mm functional contact assignments (continued)

Ball Name	14 x 14 mm VP Package Ball Position	Power Group	Signal Type ^{1, 2}	Default MUX_MODE ¹	Default Function ¹	State During Reset ³	State After Reset ^{1, 3}
PTA21	AB20	VDD_PTA	FSGPIO	0000b	ADC0_CH8B/9B/10B	Hi-Z	Hi-Z
PTA22	AC20	VDD_PTA	FSGPIO	0000b	ADC0_CH8A/9A/10A	Hi-Z	Hi-Z
PTA23	AD20	VDD_PTA	FSGPIO	0000b	ADC0_CH8B/9B/10B	Hi-Z	Hi-Z
PTA24	AF20	VDD_PTA	FSGPIO	0000b	ADC0_CH8A/9A/10A	Hi-Z	Hi-Z
PTA25	AG20	VDD_PTA	FSGPIO	0000b	ADC0_CH8B/9B/10B	Hi-Z	Hi-Z
PTA26	AF21	VDD_PTA	FSGPIO	1010b	JTAG_TMS/SWD_DIO	Input/PU	Input/PU
PTA27	AF22	VDD_PTA	FSGPIO	1010b	JTAG_TDO	Hi-Z	Hi-Z
PTA28	AG22	VDD_PTA	FSGPIO	1010b	JTAG_TDI	Input/PU	Input/PU
PTA29	AD23	VDD_PTA	FSGPIO	1010b	JTAG_TCLK/SWD_CLK	Input/PD	Input/PD
PTA30	AD24	VDD_PTA	FSGPIO	1010b	JTAG_TRST_B	Input/PU	Input/PU
PTA31	AF24	VDD_PTA	FSGPIO	0000b	ADC0_CH1B	Hi-Z	Hi-Z
PTB0	AG2	VDD_PTB	FSGPIO	0000b	ADC0_CH0A	Hi-Z	Hi-Z
PTB1	AF2	VDD_PTB	FSGPIO	0000b	ADC0_CH0B	Hi-Z	Hi-Z
PTB2	AE3	VDD_PTB	FSGPIO	0000b	ADC0_CH4A/5A/6A	Hi-Z	Hi-Z
PTB3	AE4	VDD_PTB	FSGPIO	0000b	ADC0_CH4B/5B/6B	Hi-Z	Hi-Z
PTB4	AG4	VDD_PTB	FSGPIO	0000b	BT_MODE0	Input/PD	PD
PTB5	AF4	VDD_PTB	FSGPIO	0000b	BT_MODE1	Input/PD	PD
PTB6	AF5	VDD_PTB	FSGPIO	0000b	ADC1_CH1A	Hi-Z	Hi-Z
PTB7	AF6	VDD_PTB	FSGPIO	0000b	ADC1_CH1B	Hi-Z	Hi-Z
PTB8	AG6	VDD_PTB	FSGPIO	0000b	ADC0_CH14A/CMP0_IN0	Hi-Z	Hi-Z
PTB9	AD7	VDD_PTB	FSGPIO	0000b	ADC0_CH14B/CMP0_IN2	Hi-Z	Hi-Z
PTB10	AC7	VDD_PTB	FSGPIO	0000b	CMP0_IN1	Hi-Z	Hi-Z
PTB11	AB7	VDD_PTB	FSGPIO	0000b	CMP0_IN3	Hi-Z	Hi-Z
PTB12	AC8	VDD_PTB	FSGPIO	0000b	ADC1_CH13A/CMP1_IN0	Hi-Z	Hi-Z
PTB13	AD8	VDD_PTB	FSGPIO	0000b	ADC1_CH13B/CMP1_IN1	Hi-Z	Hi-Z
PTB14	AG8	VDD_PTB	FSGPIO	0000b	ADC1_CH2A	Hi-Z	Hi-Z
PTB15	AF8	VDD_PTB	FSGPIO	0000b	ADC1_CH2B	Hi-Z	Hi-Z

Table continues on the next page...

Table 63. 14 x 14 mm functional contact assignments (continued)

Ball Name	14 x 14 mm VP Package Ball Position	Power Group	Signal Type ^{1,2}	Default MUX_MODE ¹	Default Function ¹	State During Reset ³	State After Reset ^{1,3}
PTB16	AF9	VDD_PTB	FSGPIO	0000b	ADC0_CH4A/5A/6A	Hi-Z	Hi-Z
PTB17	AF10	VDD_PTB	FSGPIO	0000b	ADC0_CH4B/5B/6B	Hi-Z	Hi-Z
PTB18	AG10	VDD_PTB	FSGPIO	0000b	ADC0_CH4A/5A/6A	Hi-Z	Hi-Z
PTB19	AD10	VDD_PTB	FSGPIO	0000b	ADC0_CH4B/5B/6B	Hi-Z	Hi-Z
PTC0	D18	VDD_PTC	FSGPIO	0000b	-	Hi-Z	Hi-Z
PTC1	E17	VDD_PTC	FSGPIO	0000b	-	Hi-Z	Hi-Z
PTC2	F17	VDD_PTC	FSGPIO	0000b	-	Hi-Z	Hi-Z
PTC3	G17	VDD_PTC	FSGPIO	0000b	-	Hi-Z	Hi-Z
PTC4	F16	VDD_PTC	FSGPIO	0000b	-	Hi-Z	Hi-Z
PTC5	D17	VDD_PTC	FSGPIO	0000b	-	Hi-Z	Hi-Z
PTC6	D16	VDD_PTC	FSGPIO	0000b	-	Hi-Z	Hi-Z
PTC7	G16	VDD_PTC	FSGPIO	0000b	-	Hi-Z	Hi-Z
PTC8	A16	VDD_PTC	FSGPIO	0000b	-	Hi-Z	Hi-Z
PTC9	B16	VDD_PTC	FSGPIO	0000b	-	Hi-Z	Hi-Z
PTC10	B15	VDD_PTC	FSGPIO	0000b	-	Hi-Z	Hi-Z
PTC11	B14	VDD_PTC	FSGPIO	0000b	-	Hi-Z	Hi-Z
PTC12	A14	VDD_PTC	FSGPIO	0000b	-	Hi-Z	Hi-Z
PTC13	D13	VDD_PTC	FSGPIO	0000b	-	Hi-Z	Hi-Z
PTC14	E13	VDD_PTC	FSGPIO	0000b	-	Hi-Z	Hi-Z
PTC15	F13	VDD_PTC	FSGPIO	0000b	-	Hi-Z	Hi-Z
PTC16	G13	VDD_PTC	FSGPIO	0000b	-	Hi-Z	Hi-Z
PTC17	G12	VDD_PTC	FSGPIO	0000b	-	Hi-Z	Hi-Z
PTC18	F12	VDD_PTC	FSGPIO	0000b	-	Hi-Z	Hi-Z
PTC19	E12	VDD_PTC	FSGPIO	0000b	-	Hi-Z	Hi-Z
PTD0	A24	VDD_PTD	STGPIO	0000b	-	Hi-Z	Hi-Z
PTD1	B24	VDD_PTD	STGPIO	0000b	-	Hi-Z	Hi-Z
PTD2	B23	VDD_PTD	STGPIO	0000b	-	Hi-Z	Hi-Z
PTD3	B22	VDD_PTD	STGPIO	0000b	-	Hi-Z	Hi-Z
PTD4	A22	VDD_PTD	STGPIO	0000b	-	Hi-Z	Hi-Z
PTD5	B21	VDD_PTD	STGPIO	0000b	-	Hi-Z	Hi-Z
PTD6	B22	VDD_PTD	STGPIO	0000b	-	Hi-Z	Hi-Z
PTD7	A20	VDD_PTD	STGPIO	0000b	-	Hi-Z	Hi-Z
PTD8	B20	VDD_PTD	STGPIO	0000b	-	Hi-Z	Hi-Z

Table continues on the next page...

Table 63. 14 x 14 mm functional contact assignments (continued)

Ball Name	14 x 14 mm VP Package Ball Position	Power Group	Signal Type ^{1, 2}	Default MUX_MODE ¹	Default Function ¹	State During Reset ³	State After Reset ^{1, 3}
PTD9	B19	VDD_PTD	STGPIO	0000b	-	Hi-Z	Hi-Z
PTD10	B18	VDD_PTD	STGPIO	0000b	-	Hi-Z	Hi-Z
PTD11	A18	VDD_PTD	STGPIO	0000b	-	Hi-Z	Hi-Z
PTE0	D12	VDD_PTE	FSGPIO	0000b	-	Hi-Z	Hi-Z
PTE1	A12	VDD_PTE	FSGPIO	0000b	-	Hi-Z	Hi-Z
PTE2	B12	VDD_PTE	FSGPIO	0000b	-	Hi-Z	Hi-Z
PTE3	B11	VDD_PTE	FSGPIO	0000b	-	Hi-Z	Hi-Z
PTE4	B10	VDD_PTE	FSGPIO	0000b	-	Hi-Z	Hi-Z
PTE5	A10	VDD_PTE	FSGPIO	0000b	-	Hi-Z	Hi-Z
PTE6	D9	VDD_PTE	FSGPIO	0000b	-	Hi-Z	Hi-Z
PTE7	E8	VDD_PTE	FSGPIO	0000b	-	Hi-Z	Hi-Z
PTE8	F9	VDD_PTE	FSGPIO	0000b	-	Hi-Z	Hi-Z
PTE9	G9	VDD_PTE	FSGPIO	0000b	-	Hi-Z	Hi-Z
PTE10	D8	VDD_PTE	FSGPIO	0000b	-	Hi-Z	Hi-Z
PTE11	A8	VDD_PTE	FSGPIO	0000b	-	Hi-Z	Hi-Z
PTE12	B8	VDD_PTE	FSGPIO	0000b	-	Hi-Z	Hi-Z
PTE13	B7	VDD_PTE	FSGPIO	0000b	-	Hi-Z	Hi-Z
PTE14	B6	VDD_PTE	FSGPIO	0000b	-	Hi-Z	Hi-Z
PTE15	A6	VDD_PTE	FSGPIO	0000b	-	Hi-Z	Hi-Z
PTF0	D2	VDD_PTF	FSGPIO	0000b	-	Input	Hi-Z
PTF1	B2	VDD_PTF	FSGPIO	0000b	-	Input	Hi-Z
PTF2	B3	VDD_PTF	FSGPIO	0000b	-	Input	Hi-Z
PTF3	C3	VDD_PTF	FSGPIO	0000b	-	Input	Hi-Z
PTF4	E2	VDD_PTF	FSGPIO	0000b	-	Input	Hi-Z
PTF5	B1	VDD_PTF	FSGPIO	0000b	-	Input	Hi-Z
PTF6	A2	VDD_PTF	FSGPIO	0000b	-	Input	Hi-Z
PTF7	F2	VDD_PTF	FSGPIO	0000b	-	Input	Hi-Z
PTF8	F1	VDD_PTF	FSGPIO	0000b	-	Input	Hi-Z
PTF9	D1	VDD_PTF	FSGPIO	0000b	-	Input	Hi-Z
PTF10	G5	VDD_PTF	FSGPIO	0000b	-	Input	Hi-Z
PTF11	G6	VDD_PTF	FSGPIO	0000b	-	Input	Hi-Z
PTF12	H7	VDD_PTF	FSGPIO	0000b	-	Input	Hi-Z
PTF13	H6	VDD_PTF	FSGPIO	0000b	-	Input	Hi-Z
PTF14	H5	VDD_PTF	FSGPIO	0000b	-	Input	Hi-Z
PTF15	H4	VDD_PTF	FSGPIO	0000b	-	Input	Hi-Z
PTF16	H1	VDD_PTF	FSGPIO	0000b	-	Hi-Z	Hi-Z

Table continues on the next page...

Table 63. 14 x 14 mm functional contact assignments (continued)

Ball Name	14 x 14 mm VP Package Ball Position	Power Group	Signal Type ^{1, 2}	Default MUX_MODE ¹	Default Function ¹	State During Reset ³	State After Reset ^{1, 3}
PTF17	H2	VDD_PTF	FSGPIO	0000b	-	Hi-Z	Hi-Z
PTF18	J2	VDD_PTF	FSGPIO	0000b	-	Hi-Z	Hi-Z
PTF19	K2	VDD_PTF	FSGPIO	0000b	-	Hi-Z	Hi-Z
RESET0_B	AC11	VDD_PT	RESET	-	RESET0_B	Output/OD	Input/PU
RESET1_B	K1	VDD_PTF	RESET	-	RESET1_B	Output/OD	Input/PU
STANDBY_REQ	V2	VDD_VBAT1 8_CAP	SNVS	-	STANDBY_REQ	Output/Low	Output/Low
TAMPER	V4	VDD_VBAT1 8_CAP	SNVS	-	TAMPER	Hi-Z ⁴	Input
TESTCLK_N	AA8	VDD_PT	-	-	TESTCLK_N	-	-
TESTCLK_P	AB8	VDD_PT	-	-	TESTCLK_P	-	-
USB0_DM	T2	VDD_USB33	USB PHY	-	USB0_DM	-	-
USB0_DP	T1	VDD_USB33	USB PHY	-	USB0_DP	-	-
USB0_VBUS_DETECT	T4	VDD_USB33	USB PHY	-	USB0_VBUS_DETECT	-	-
XTAL	AA2	VDD_PMC18	Analog	-	XTAL	-	-
XTAL32	Y4	VDD_VBAT1 8_CAP	Analog	-	XTAL32	-	-

1. The state immediately after RESET and before ROM firmware or software has executed.
2. FSGPIO = Failsafe GPIOs; STGPIO - Standard GPIOs
3. PD = internal pull-down enabled; PU = internal pull-up enabled; OD = open-drain
4. TAMPER is Hi-Z during VBAT domain POR and an input otherwise.

11 Revision History

The following table provides a revision history for this document.

The changes shown below represent the changes between the i.MX 7ULP datasheet for silicon revision B1 (IMX7ULPIEC) and silicon revision B2 (IMX7ULPB2IEC).

Table 64. Revision History

Rev. No.	Date	Substantial Changes
0	04/2021	<ul style="list-style-type: none"> • Updated orderable part number for B2 silicon on the front page and this table • Updated Figure 2. • In this table, updated Nominal and Overdrive frequency for CM4. • Added this table • Added a row for B2 silicon revision in Table 3. • Added i.MX 7ULP LDO Bypass versus LDO-enabled modes

Table continues on the next page...

Table 64. Revision History (continued)

Rev. No.	Date	Substantial Changes
		<ul style="list-style-type: none"> • In Table 5, updated parameters for real Time Domain (M4 domain) PMC 0 Register Configuration Requirements and Application Domain (A7 domain) supply voltage requirements for LDO Bypass modes . • Updated value for open loop total deviation of IRC16M frequency at low voltage in Table 9 • Added the section HS200 mode timing. • Removed external channel leakage current spec from the section 12-bit ADC electrical specifications • Removed the section "Fuse definition of Speed Grading" • Minor editorial changes • Updated DDR frequency from 380.16 to 271.5 MHz throughout.
1	07/2021	<ul style="list-style-type: none"> • Updated the power-on hours from 2190 to 8760 in the footnote 9 of Table 5.

How To Reach Us

Home Page:

nxp.com

Web Support:

nxp.com/support

Limited warranty and liability — Information in this document is believed to be accurate and reliable. However, NXP Semiconductors does not give any representations or warranties, expressed or implied, as to the accuracy or completeness of such information and shall have no liability for the consequences of use of such information. NXP Semiconductors takes no responsibility for the content in this document if provided by an information source outside of NXP Semiconductors. In no event shall NXP Semiconductors be liable for any indirect, incidental, punitive, special or consequential damages (including - without limitation - lost profits, lost savings, business interruption, costs related to the removal or replacement of any products or rework charges) whether or not such damages are based on tort (including negligence), warranty, breach of contract or any other legal theory.

Notwithstanding any damages that customer might incur for any reason whatsoever, NXP Semiconductors' aggregate and cumulative liability towards customer for the products described herein shall be limited in accordance with the Terms and conditions of commercial sale of NXP Semiconductors.

Right to make changes - NXP Semiconductors reserves the right to make changes to information published in this document, including without limitation specifications and product descriptions, at any time and without notice. This document supersedes and replaces all information supplied prior to the publication hereof.

Security — Customer understands that all NXP products may be subject to unidentified or documented vulnerabilities. Customer is responsible for the design and operation of its applications and products throughout their lifecycles to reduce the effect of these vulnerabilities on customer's applications and products. Customer's responsibility also extends to other open and/or proprietary technologies supported by NXP products for use in customer's applications. NXP accepts no liability for any vulnerability. Customer should regularly check security updates from NXP and follow up appropriately.

Customer shall select products with security features that best meet rules, regulations, and standards of the intended application and make the ultimate design decisions regarding its products and is solely responsible for compliance with all legal, regulatory, and security related requirements concerning its products, regardless of any information or support that may be provided by NXP. NXP has a Product Security Incident Response Team (PSIRT) (reachable at PSIRT@nxp.com) that manages the investigation, reporting, and solution release to security vulnerabilities of NXP products.

Suitability for use — NXP Semiconductors products are not designed, authorized or warranted to be suitable for use in life support, life-critical or safety-critical systems or equipment, nor in applications where failure or malfunction of an NXP Semiconductors product can reasonably be expected to result in personal injury, death or severe property or environmental damage. NXP Semiconductors and its suppliers accept no liability for inclusion and/or use of NXP Semiconductors products in such equipment or applications and therefore such inclusion and/or use is at the customer's own risk.

Non-automotive qualified products — Unless this data sheet expressly states that this specific NXP Semiconductors product is automotive qualified, the product is not suitable for automotive use. It is neither qualified nor tested in accordance with automotive testing or application requirements. NXP Semiconductors accepts no liability for inclusion and/or use of non-automotive qualified products in automotive equipment or applications.

In the event that customer uses the product for design-in and use in automotive applications to automotive specifications and standards, customer (a) shall use the product without NXP Semiconductors' warranty of the product for such automotive applications, use and specifications, and (b) whenever customer uses the product for automotive applications beyond NXP Semiconductors' specifications such use shall be solely at customer's own risk, and (c) customer fully indemnifies NXP Semiconductors for any liability, damages or failed product claims resulting from customer design and use of the product for automotive applications beyond NXP Semiconductors' standard warranty and NXP Semiconductors' product specifications.

Applications — Applications that are described herein for any of these products are for illustrative purposes only. NXP Semiconductors makes no representation or warranty that such applications will be suitable for the specified use without further testing or modification.

Customers are responsible for the design and operation of their applications and products using NXP Semiconductors products, and NXP Semiconductors accepts no liability for any assistance with applications or customer product

Table continues on the next page...

design. It is customer's sole responsibility to determine whether the NXP Semiconductors product is suitable and fit for the customer's applications and products planned, as well as for the planned application and use of customer's third party customer(s). Customers should provide appropriate design and operating safeguards to minimize the risks associated with their applications and products.

NXP Semiconductors does not accept any liability related to any default, damage, costs or problem which is based on any weakness or default in the customer's applications or products, or the application or use by customer's third party customer(s). Customer is responsible for doing all necessary testing for the customer's applications and products using NXP Semiconductors products in order to avoid a default of the applications and the products or of the application or use by customer's third party customer(s). NXP does not accept any liability in this respect.

Limiting values — Stress above one or more limiting values (as defined in the Absolute Maximum Ratings System of IEC 60134) will cause permanent damage to the device. Limiting values are stress ratings only and (proper) operation of the device at these or any other conditions above those given in the Recommended operating conditions section (if present) or the Characteristics sections of this document is not warranted. Constant or repeated exposure to limiting values will permanently and irreversibly affect the quality and reliability of the device.

Terms and conditions of commercial sale — NXP Semiconductors products are sold subject to the general terms and conditions of commercial sale, as published at <http://www.nxp.com/profile/terms>, unless otherwise agreed in a valid written individual agreement. In case an individual agreement is concluded only the terms and conditions of the respective agreement shall apply. NXP Semiconductors hereby expressly objects to applying the customer's general terms and conditions with regard to the purchase of NXP Semiconductors products by customer.

Hazardous voltage — Although basic supply voltages of the product may be much lower, circuit voltages up to 60 V may appear when operating this product, depending on settings and application. Customers incorporating or otherwise using these products in applications where such high voltages may appear during operation, assembly, test etc. of such application, do so at their own risk. Customers agree to fully indemnify NXP Semiconductors for any damages resulting from or in connection with such high voltages. Furthermore, customers are drawn to safety standards (IEC 950, EN 60 950, CENELEC, ISO, etc.) and other (legal) requirements applying to such high voltages.

Bare die — All die are tested on compliance with their related technical specifications as stated in this data sheet up to the point of wafer sawing and are handled in accordance with the NXP Semiconductors storage and transportation conditions. If there are data sheet limits not guaranteed, these will be separately indicated in the data sheet. There are no post-packing tests performed on individual die or wafers.

NXP Semiconductors has no control of third party procedures in the sawing, handling, packing or assembly of the die. Accordingly, NXP Semiconductors assumes no liability for device functionality or performance of the die or systems after third party sawing, handling, packing or assembly of the die. It is the responsibility of the customer to test and qualify their application in which the die is used. All die sales are conditioned upon and subject to the customer entering into a written die sale agreement with NXP Semiconductors through its legal department.

Export control — This document as well as the item(s) described herein may be subject to export control regulations. Export might require a prior authorization from competent authorities.

NXP, the NXP logo, NXP SECURE CONNECTIONS FOR A SMARTER WORLD, EdgeLock, are trademarks of NXP B.V. All other product or service names are the property of their respective owners. AMBA, Arm, Arm7, Arm7TDMI, Arm9, Arm11, Artisan, big.LITTLE, Cordio, CoreLink, CoreSight, Cortex, DesignStart, DynamIQ, Jazelle, Keil, Mali, Mbed, Mbed Enabled, NEON, POP, RealView, SecurCore, Socrates, Thumb, TrustZone, ULINK, ULINK2, ULINK-ME, ULINK-PLUS, ULINKpro, μ Vision, Versatile are trademarks or registered trademarks of Arm Limited (or its subsidiaries) in the US and/or elsewhere. The related technology may be protected by any or all of patents, copyrights, designs and trade secrets. All rights reserved.



© NXP B.V. 2021.

All rights reserved.

For more information, please visit: <http://www.nxp.com>

For sales office addresses, please send an email to: salesaddresses@nxp.com

Date of release: 07/2021 Document

Identifier: IMX7ULPIECB2