

The Maximum Supply Current That Wasn't

By Harry Holt, Staff Applications Engineer, Analog Devices, Inc.

IDEA IN BRIEF

For most integrated circuits, a maximum supply current is listed on the data sheet. Often overlooked are the measurement conditions. For some rail-to-rail output op amps, certain operation can result in supply currents two to ten times higher than the stated maximum. Whether bipolar or CMOS, some tips are given as to what to look for to see whether or not this is a concern.

Almost all integrated circuit data sheets have a guaranteed maximum supply current, but you cannot always use this number for your worst case power calculations. It's well known that CMOS digital parts have a supply current that increases as clock frequency increases, but what about analog parts, specifically op amps? Can you use the supply current plus the current supplied to the load as a maximum? (Hint: not always.....)

Op amps are designed to be operated closed loop, while comparators are operated open loop. Although this simple statement is obvious, seldom do we think about the ramifications of violating this. The more frequent problem is when operating an op amp as a comparator. It is tempting, because many op amps are designed to have very low offset and very low noise, so they are pressed into service as precision comparators. When op amps were powered on ± 15 V, and input signals were within ± 10 V, this worked somewhat, especially if some positive hysteresis was added to avoid oscillations and speed up the transition through the uncertainty region. The problem became serious with the advent of rail-to-rail output op amps. For a good explanation of the input and output stages, see (1) in the References section.

History

In the digital world, NAND gates, NOR gates, etc., had distinctive MIL/ANSI symbols, but in the analog world, for some unknown reason, op amps and comparators were shown as a triangle with two inputs and one output, "and that has made all the difference"(2). Op amps have been used as comparators for quite awhile and many articles have been written about both comparators, and op amps used as comparators. As far back as 1967, when the LM101A was introduced, the data sheet showed an application circuit using it as a comparator. Tutorial MT-083 (3) is a good, general discussion of comparators, covering how comparators are specified and the need for hysteresis with comparators, but does not discuss using op amps as comparators. Sylvan (4) discusses the general considerations when using op amps as comparators but does not discuss rail-to-rail output op amps specifically. He does warn about the input differences with respect to common-mode input voltage and touches on the differences in differential mode voltages. Bryant (5) starts by saying "However, the best advice on using an op amp as comparator is very simple—don't!" and then covers a variety of things to consider, concluding that in some applications, it may be a proper engineering decision. Kester (6) also warns against using op amps as comparators, and grudgingly admits there are a few cases where it might make sense. Moghimi (7) discusses the differences between op amps and comparators, warning, "the devil is in the details" and does an excellent job covering

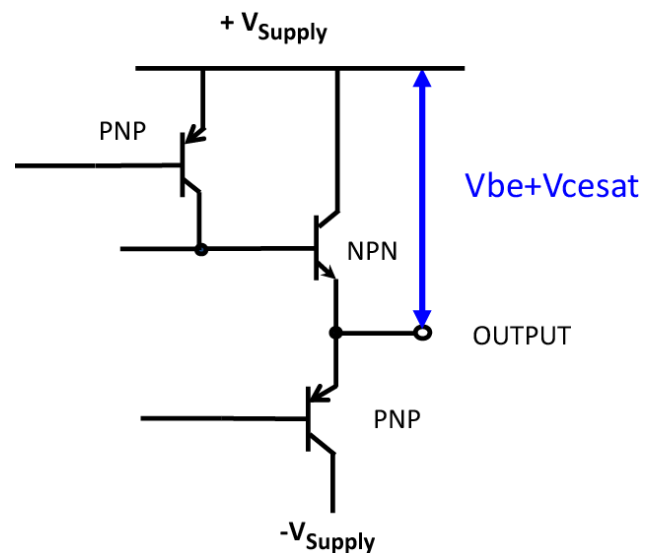

Figure 1. Classic bipolar output stage

input protection diodes, phase reversal, and several other op amp characteristics but argues that careful attention to these details can pay off. He does briefly mention RRO op amps, but not supply current.

As supply voltages decreased, one of the methods used to try to maintain a large voltage swing, was to convert the classic output stage to a “rail to rail” output stage. A classic output stage is shown in Figure 1. Referring to the non-rail-to-rail output, the output can only get within about 1 V of the positive supply.

To get closer to the rails, the output stage transistors were changed to a common emitter configuration as shown in Figure 2.

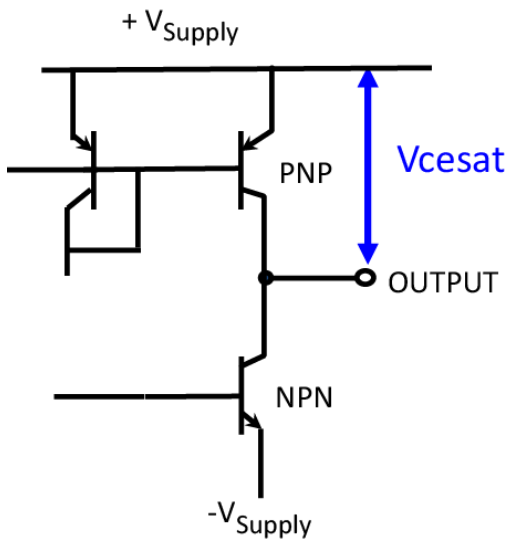

Figure 2. Bipolar rail-to-rail output

The “rail-to-rail” output is not really rail-to-rail, but can get within 50 mV to 100 mV of the supply depending on the size of the output transistor and the load current.

Comparing these two output stages, there are three important things to note: First, the classic output stage has current gain, but a voltage gain less than one, and very low output impedance. Second, the rail-to-rail output stage is a common emitter stage and, thus, has voltage gain, approximately $g_m \times R_L$. R_L is composed of the external load and the output impedance (R_O) of the transistor. With the output operating more than several hundred millivolts away from the rail, R_O is very large and can usually be neglected, but *not* if the output is close to the rail. Third, the output can be considered as a classic two transistor ratioed current mirror. This is the crux of the problem.

In normal operation, the middle stage will pull the base-collector node down, driving more current into the load and raising the voltage. With negative feedback, as the output voltage rises, the input stage and middle stage will reduce the drive until the closed loop is balanced.

When used as a comparator, the middle stage will pull the base-collector node down, trying to close the loop, but with no feedback, it continues to pull harder and harder. This additional current finds a path from the positive supply pin to the negative supply pin and appears as additional supply current. There are several different ways of driving the output stage, and combined with the difference in mobility between holes and electrons, the increase in supply current is usually not symmetrical.

To quantify this effect, a bipolar op amp and a CMOS op amp were obtained from Analog Devices and three of its major analog competitors. For comparison purposes, the venerable LM358 dual op amp (non-RRO) and LM393 dual comparator were also included. The supply current was measured as a function of supply voltage using three circuits. Figure 3 shows the classic method for measuring supply current. The ammeters are connected as shown so that the supply current of the resistive divider is not included.

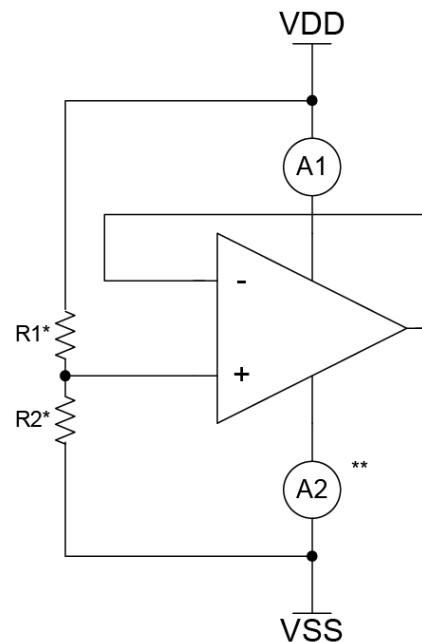

Figure 3.

Two ammeters are used to verify that the supply current is accurate and does not include any undesired current path through the input pins. The resistor values are noncritical, and are selected to ensure that the input to the op amp is

within the specified input voltage range (IVR) from the data sheet specification table.

To measure supply current when open loop, such as operation as a comparator, see Figure 4 and Figure 5. Some low noise, bipolar op amps have diodes between the inputs to protect the differential input pair, so the maximum differential voltage is usually stated in the Absolute Maximum table as ± 0.7 V. If there are internal series resistors, they are usually in the $500\ \Omega$ to $2\ \text{k}\Omega$ range. The Absolute Maximum table may state that the maximum differential voltage is \pm supply voltage, but this does *not* mean that the part operates. A simplified internal schematic should be consulted. If one is not provided, a quick call to the manufacturer can resolve this. In these two configurations, the choice of resistor values is a little more critical. The resistor values should be low enough to cause the differential input voltage to be at least 0.5 V to guarantee that the output is driven hard into the rail but high enough not to damage the internal diodes. Values were chosen to limit the input current to less than 1 mA.

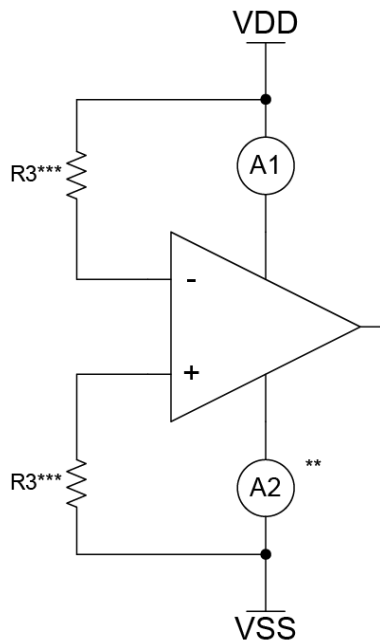

Figure 4. Comparator, output low

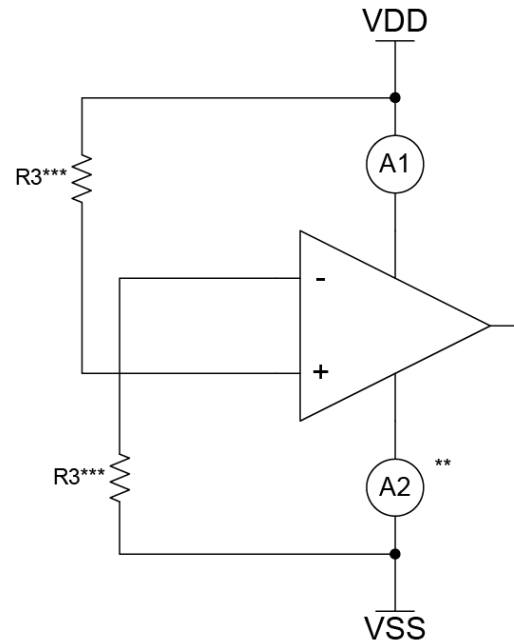

Figure 5. Comparator, output high

Table 1 lists the maximum supply current specification from the data sheets, the measured supply current with the op amp connected as a follower with V_{IN} halfway between the supply pins (Figure 3), and the supply current with the output forced low (Figure 4) and forced high (Figure 5).

Classic op amp and comparator

Table 1 shows that the classic LM358 and LM393 are well behaved, as expected.

Bipolar Rail-to-Rail Op Amps

All the bipolar rail-to-rail output op amps have supply current greater than the “maximum” op amp supply current in one or both comparator circuits. There are several ways to drive the output stage, so some methods will result in a supply current increase when driving to one rail or the other. Without being privy a manufacturer’s internal schematics, one cannot comment on the behavior.

For the OP284, the second stage and output stage simplified schematic is shown on the data sheet. See Figure 6.

If V_{OUT} is driven high by Q5/Q3/Q4, the supply current will be a function of the values of R4 and R6. These values are selected to maximize the op amp performance and minimize die area, not comparator operation. When V_{OUT} is driven low by Q6/R1/Q1, the supply current will be determined by R1. Again, the values of R1, I1, etc. are chosen for op amp performance, not comparator performance.

Table 1.

Competitor	Type		Spec (mA)	Follower (mA)	Vol (mA)	Voh (mA)
LM358	Bipolar	30V	2	0.707	0.506	0.671
LM393	Bipolar	36V	2.5	0.548	0.565	0.567
OP184	Bipolar	30V	2	1.239	1.188	6.683
A	Bipolar	24V	0.45	0.361	3.442	0.708
B	Bipolar	30V	3.4	2.785	2.051	3.998
C	Bipolar	30V	4.5	4.063	5.336	3.786
AD8605	CMOS	5V	1.2	0.998	0.544	0.625
A	CMOS	5V	0.9	0.511	0.361	10.152
B	CMOS	5V	2.4	1.916	2.759	2.475
C	CMOS	5V	1.4	1.039	0.822	0.667

Red highlighted values indicate exceeds data sheet limit.

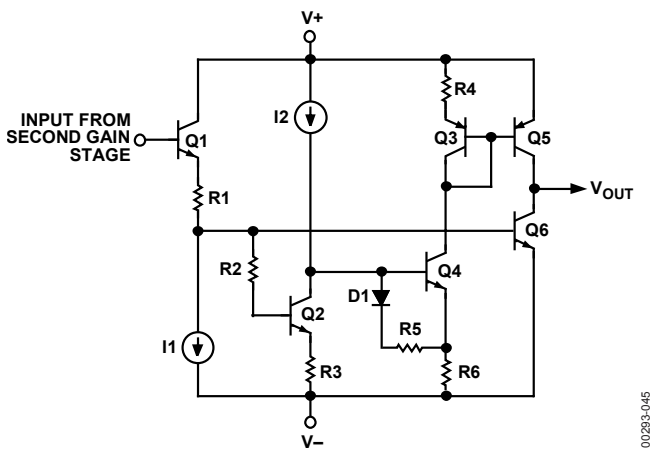

Figure 6.

CMOS Rail-to-Rail Op Amps

The CMOS op amps have an interesting behavior. In some cases, the supply current actually goes down when driven to a rail. The output stage of a CMOS op amp consists of common source PMOS and NMOS transistors, and gain is taken in the output stage. The gain is $g_m \times R_L$, and to get a reasonable value of transconductance, the drive circuit is designed to set the quiescent current to a certain value. As the output is driven into the rail, the drive circuit will decrease the drive on the complementary transistor. Depending on the transfer characteristics from the top transistor to the bottom transistor, the current will actually decrease. Note the wide variation in behavior among the four CMOS op amps selected.

Finally, in the desire to reduce die size and, therefore, cost, some circuits, such as bias circuits and the associated startup circuit, may be shared by both op amps. As mentioned previously (8), if one op amp operates outside of its normal range and causes the bias circuit to malfunction, then the other op amp will malfunction also.

In battery operated systems or when using low current series regulators, the additional supply current should be considered. Battery life may be less than calculated, or the regulator may not start up under all conditions, especially over temperature.

Tips

For new designs, the easiest solution is “Don’t use op amps as comparators!” If you must, or have used one by accident as a comparator:

- Check the data sheet to see if the manufacturer has any information on operation as a comparator. Some manufacturers are adding this information (9,10).
- If the information is not there, ask the manufacturer if it is available.
- If they cannot provide it, measure several date codes yourself using the circuits shown previously, and add 50% for a safety factor.

Summary

Rail-to-rail output op amps have unique characteristics when operated as comparators.

The best solutions to improving battery life and increasing performance are to use a low cost comparator when a comparator function is required, tying off any used op amp sections as followers with the noninverting input connected to a stable voltage within the input voltage range of the op amp, or using singles and duals as appropriate instead of quads. Supply current may greatly exceed the “Max” stated on the data sheet. Under carefully considered conditions, unused op amps can be used as comparators, but using the proper mix of op amps and comparators will result in lower supply current and well-defined performance.

REFERENCES

1. Kester, Walt “Op Amp Inputs, Outputs, Single-Supply, and Rail-to-Rail Issues” MT-035 Tutorial www.analog.com/MT-035
2. Frost, Robert “Mountain Interval” New York: Henry Holt & Company, 1920.
3. ”Comparators” MT-083 Tutorial www.analog.com/MT-083
4. Sylvan, John, “High-speed comparators provide many useful circuit functions when used correctly” *Analog Dialogue*, Ask the Applications Engineer— 5 www.analog.com/analogdialogue
5. Bryant, James “Using Op Amps as Comparators” 2006 AN-849 at www.analog.com/AN-849
6. Kester, Walt “Using Op Amps As Comparators” MT-084 Tutorial www.analog.com/MT-084
7. Moghimi, Reza “Amplifiers as Comparators?” *Analog Dialogue* Ask the Applications Engineer—31 www.analog.com/analogdialogue
8. Holt, Harry ”OP Amps: To Dual or Not to Dual” www.eetimes.com
9. ADA4092-4 data sheet www.analog.com/ADA4092-4
10. AD8657 data sheet www.analog.com/AD8657

RESOURCES

For resources and information on op amps, visit www.analog.com/opamps.

Products Mentioned in This Article

Product	Description
OP184	Single-Supply Rail-to-Rail Input/Output Operational Amplifier
OP284	Dual Precision Rail-to-Rail Input/Output Operational Amplifier
AD8605	Precision, Low Noise, CMOS, Rail-to-Rail Input/Output Operational Amplifier
ADA4092-4	Micropower, OVP, Rail-to-Rail Input/Output Operational Amplifier
AD8657	Precision, Micropower 18 V CMOS Rail-to-Rail Input/Output Operational Amplifier

ABOUT THE AUTHOR

Harry Holt is a staff applications engineer at Analog Devices (San Jose, CA) in the Precision Amplifiers Group where he has worked for four years, following 27 years in both field and factory applications at National Semiconductor for a variety of products, including data converters, op amps, references, audio codecs, and FPGAs. He has a BSEE from San Jose State University and is a life member of Tau Beta Pi and a Senior Member of the IEEE.