

SN75LPE185 LOW-POWER MULTIPLE RS-232 DRIVERS/RECEIVERS WITH ENABLE

SLLS256F – DECEMBER 1996 – REVISED NOVEMBER 2001

- **Single-Chip RS-232 Interface for IBM™ PC-Compatible Serial Port**
- **Designed to Transmit and Receive 4- μ s Pulses (Equivalent to 256 kbit/s)**
- **Standby Power Is Less Than 750 μ W Maximum**
- **Wide Supply-Voltage Range . . . 4.75 V to 15 V**
- **Driver Output Slew Rates Are Internally Controlled to 30 V/ μ s Maximum**
- **RS-232 Bus-Pin ESD Protection Exceeds:**
– 15 kV, Human-Body Model
- **Receiver Input Hysteresis . . . 1000 mV Typical**
- **Three Drivers and Five Receivers Meet or Exceed the Requirements of TIA/EIA-232-F and ITU v.28 Standards**
- **Complements the SN75LP196**
- **One Receiver Remains Active During WAKE-UP Mode (100 μ A Maximum)**
- **Matches Flow-Through Pinout of Industry-Standard SN75185, SN75C185, and SN75LP185, With Additional Control Pins**
- **Package Options Include Plastic Shrink Small-Outline (DB), Small-Outline (DW), and Thin Shrink Small-Outline (PW) Packages, and Standard Plastic (NT) DIPs**

DB, DW, NT, OR PW PACKAGE
(TOP VIEW)

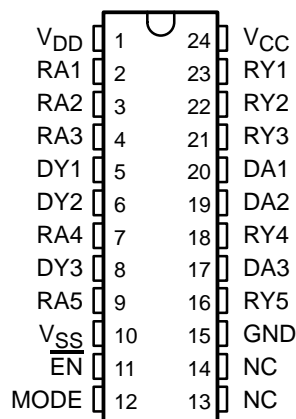

NC – No internal connection

description

The SN75LPE185 is a low-power bipolar device containing three drivers and five receivers, with 15-kV ESD protection on the bus pins, with respect to each other. Bus pins are defined as those pins that tie directly to the serial-port connector, including GND. The pinout matches the flow-through design of the industry-standard SN75185, SN75C185, and SN75LP185, with the addition of four pins for control signals. The flow-through pinout of the device allows easy interconnection of the universal asynchronous receiver/transmitter (UART) and serial-port connector of the IBM™ PC compatibles. The SN75LPE185 provides a rugged, low-cost solution for this function, with the combination of bipolar processing and 15-kV ESD protection.

The SN75LPE185 has an internal slew-rate control to provide a maximum rate of change in the output signal of 30 V/ μ s. The driver output swing is clamped at ± 6 V to enable the higher data rates associated with this device and to reduce EMI emissions. Although the driver outputs are clamped, the outputs can handle voltages up to ± 15 V without damage.



Please be aware that an important notice concerning availability, standard warranty, and use in critical applications of Texas Instruments semiconductor products and disclaimers thereto appears at the end of this data sheet.

IBM is a trademark of International Business Machines Corporation.

PRODUCTION DATA information is current as of publication date. Products conform to specifications per the terms of Texas Instruments standard warranty. Production processing does not necessarily include testing of all parameters.



Copyright © 2001, Texas Instruments Incorporated

SN75LPE185 LOW-POWER MULTIPLE RS-232 DRIVERS/RECEIVERS WITH ENABLE

SLLS256F – DECEMBER 1996 – REVISED NOVEMBER 2001

description (continued)

The device has flexible control options for power management when the serial port is inactive. A common disable for all of the drivers and receivers is provided with the active-low enable (\overline{EN}) input. The mode-control (MODE) input selects between the STANDBY and WAKE-UP modes. With a low-level input on MODE and a high-level input on \overline{EN} , one receiver remains active, while the remaining drivers and receivers are disabled to implement the WAKE-UP mode. With a high-level input on both MODE and \overline{EN} , all drivers and receivers are disabled to implement the STANDBY mode. The outputs of the drivers are in the high-impedance state when the device is powered off. To ensure the outputs of the receivers are in a known output level (as listed in the *Application Information* section of this data sheet) when the device is powered off, in STANDBY mode, or in WAKE-UP mode, external pullup/pulldown circuitry must be provided. All the logic inputs accept 3.3-V or 5-V input signals.

The SN75LPE185 complies with the requirements of TIA/EIA-232-F and ITU v.28 standards. These standards are for data interchange between a host computer and peripheral at signaling rates up to 20 kbit/s. The switching speeds of the SN75LPE185 support rates up to 256 kbit/s.

The SN75LPE185 is characterized for operation from 0°C to 70°C.

AVAILABLE OPTIONS

T _A	PACKAGED DEVICES			
	PLASTIC SHRINK SMALL OUTLINE (DB)	PLASTIC SMALL OUTLINE (DW)	PLASTIC THIN SHRINK SMALL OUTLINE (PW)	PLASTIC DIP (NT)
0°C to 70°C	SN75LPE185DBR	SN75LPE185DW	SN75LPE185PWR	SN75LPE185NT

The DB and PW packages are only available taped and reeled. The DW package is also available taped and reeled. Add the suffix R to device type (e.g., SN75LPE185DWR).

Function Tables

DRIVERS

INPUT DA	ENABLE \overline{EN}	OUTPUT DY
X	H	Z
H	L	L
L	L	H
Open	L	L
H	Open	L
L	Open	H

H = high level, L = low level,
X = irrelevant, Z = high impedance (off)

Function Tables (Continued)

RECEIVERS

INPUTS		ENABLE INPUTS		OUTPUTS	
RA1–RA4	RA5	\overline{EN}	MODE	RY1–RY4	RY5
H	H	L	X	L	L
L	L	L	X	H	H
X	H	H	L	Z	L
X	L	H	L	Z	H
X	X	H	H	Z	Z
Open	Open	L	X	H	H
H	H	L	Open	L	L
L	L	L	Open	H	H
X	H	H	Open	Z	L
X	L	H	Open	Z	H
H	H	Open	X	L	L
L	L	Open	X	H	H

H = high level, L = low level, X = irrelevant, Z = high impedance (off)

functional logic diagram (positive logic)

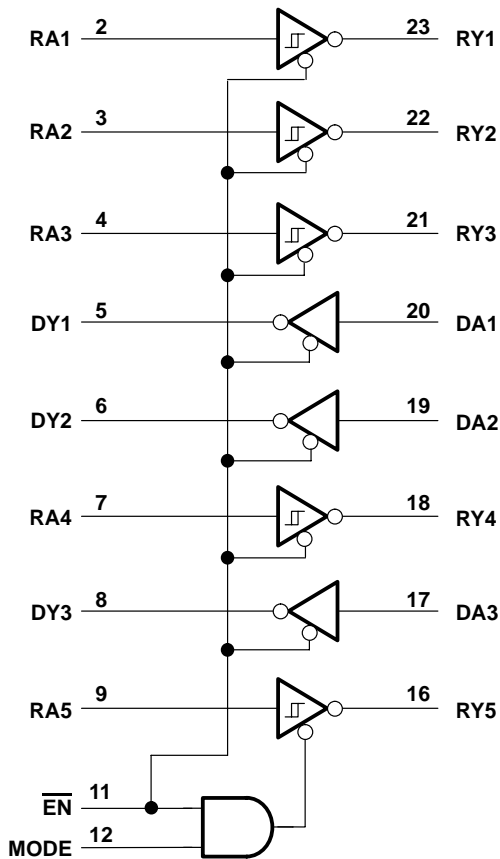

SN75LPE185

LOW-POWER MULTIPLE RS-232 DRIVERS/RECEIVERS WITH ENABLE

SLLS256F – DECEMBER 1996 – REVISED NOVEMBER 2001

absolute maximum ratings over operating free-air temperature range (unless otherwise noted)†

Positive supply voltage range: V_{CC} (see Note 1)	-0.5 V to 7 V
V_{DD} (see Note 1)	-0.5 V to 15 V
Negative supply voltage range, V_{SS} (see Note 1)	0.5 V to -15 V
Receiver input voltage range, V_I (RA)	-30 V to 30 V
Driver input voltage range, V_I (DA, \overline{EN} , MODE)	-0.5 V to $V_{CC} + 0.4$ V
Receiver output voltage range, V_O (RY)	-0.5 V to 6 V
Driver output voltage range, V_O (DY)	-15 V to 15 V
Electrostatic discharge, bus pins: Human-body model (see Note 2)	Class 3: 15 kV
Machine model (see Note 2)	Class 3: 500 V
Electrostatic discharge, all pins: Human-body model (see Note 2)	Class 3: 5 kV
Machine model (see Note 2)	Class 3: 200 V
Package thermal impedance, θ_{JA} (see Note 3): DB package	63°C/W
(see Note 3): DW package	46°C/W
(see Note 4): NT package	67°C/W
(see Note 3): PW package	88°C/W
Lead temperature 1,6 mm (1/16 inch) from case for 10 seconds	260°C
Storage temperature range, T_{stg}	-65°C to 150°C

† Stresses beyond those listed under “absolute maximum ratings” may cause permanent damage to the device. These are stress ratings only, and functional operation of the device at these or any other conditions beyond those indicated under “recommended operating conditions” is not implied. Exposure to absolute-maximum-rated conditions for extended periods may affect device reliability.

- NOTES:
1. All voltage values are with respect to network ground terminal unless otherwise noted.
 2. Per MIL-STD-883 Method 3015.7
 3. The package thermal impedance is calculated in accordance with JESD 51-7.
 4. The package thermal impedance is calculated in accordance with JESD 51-3.

recommended operating conditions

		MIN	NOM	MAX	UNIT	
V_{CC}	Supply voltage (see Note 5)	4.75	5	5.25	V	
V_{DD}	Supply voltage	9	12	15	V	
V_{SS}	Supply voltage	-9	-12	-15	V	
V_{IH}	High-level input voltage	DA, \overline{EN} , MODE		2	V	
V_{IL}	Low-level input voltage	DA, \overline{EN} , MODE		0.8	V	
V_I	Receiver input voltage range	RA		-25	25	V
I_{OH}	High-level output current	RY		-1	mA	
I_{OL}	Low-level output current	RY		2	mA	
T_A	Operating free-air temperature	0	70		°C	

NOTE 5: V_{CC} cannot be greater than V_{DD} .



SN75LPE185 LOW-POWER MULTIPLE RS-232 DRIVERS/RECEIVERS WITH ENABLE

SLLS256F – DECEMBER 1996 – REVISED NOVEMBER 2001

supply currents over the recommended operating conditions (unless otherwise noted)

PARAMETER		TEST CONDITIONS	MIN	TYP	MAX	UNIT
I _{CC}	Supply current for V _{CC}	No load, All inputs at minimum V _{OH} or maximum V _{OL}	V _{DD} = 9 V, V _{SS} = -9 V, $\overline{\text{EN}}$ at GND, See Note 6		1000	μA
			V _{DD} = 12 V, V _{SS} = -12 V, $\overline{\text{EN}}$ at GND		1000	
			$\overline{\text{EN}}$, MODE at V _{CC}		650	
			$\overline{\text{EN}}$ at V _{CC} , MODE at GND		700	
I _{DD}	Supply current for V _{DD}	No load, All inputs at minimum V _{OH} or maximum V _{OL}	V _{DD} = 9 V, V _{SS} = -9 V, $\overline{\text{EN}}$ at GND, See Note 6		800	μA
			V _{DD} = 12 V, V _{SS} = -12 V, $\overline{\text{EN}}$ at GND		800	
			$\overline{\text{EN}}$, MODE at V _{CC}		20	
			$\overline{\text{EN}}$ at V _{CC} , MODE at GND		20	
I _{SS}	Supply current for V _{SS}	No load, All inputs at minimum V _{OH} or maximum V _{OL}	V _{DD} = 9 V, V _{SS} = -9 V, $\overline{\text{EN}}$ at GND, See Note 6		-625	μA
			V _{DD} = 12 V, V _{SS} = -12 V, $\overline{\text{EN}}$ at GND		-625	
			$\overline{\text{EN}}$, MODE at V _{CC}		-50	
			$\overline{\text{EN}}$ at V _{CC} , MODE at GND		-50	

NOTE 6: Minimum RS-232 driver output voltages are not attained with ±5-V supplies.

driver electrical characteristics over the recommended operating conditions (unless otherwise noted)

PARAMETER		TEST CONDITIONS	MIN	TYP	MAX	UNIT		
V _{OH}	High-level output voltage	V _I = 0.8 V, R _L = 3 kΩ, See Figure 1	V _{DD} = 9 V, V _{SS} = -9 V, $\overline{\text{EN}}$ at GND, See Note 6		5	5.8	6.6	V
			V _{DD} = 12 V, V _{SS} = -12 V, $\overline{\text{EN}}$ at GND, See Note 7		5	5.8	6.6	
V _{OL}	Low-level output voltage	V _I = 2 V, R _L = 3 K, See Figure 1	V _{DD} = 9 V, V _{SS} = -9 V, $\overline{\text{EN}}$ at GND, See Note 6		-5	-5.8	-6.9	V
			V _{DD} = 12 V, V _{SS} = -12 V, $\overline{\text{EN}}$ at GND, See Note 7		-5	-5.8	-6.9	
I _{IH}	High-level input current	V _I at V _{CC}				1	μA	
I _{IL}	Low-level input current	V _I at GND				-1	μA	
I _{OZ}	High-impedance output current	V _{CC} = 5 V, V _{DD} = 12 V, V _{SS} = -12 V, -5 V ≤ V _O ≤ 5 V				±100	μA	
I _{OS(H)}	Short-circuit high-level output current	V _O = GND or V _{SS} .	See Figure 2 and Note 8			-30	-55	mA
I _{OS(L)}	Short-circuit low-level output current	V _O = GND or V _{SS} .	See Figure 2 and Note 8			30	55	mA
r _o	Output resistance	V _{DD} = V _{SS} = V _{CC} = 0, V _O = 2 V				300	Ω	

NOTES: 6. Minimum RS-232 driver output voltages are not attained with ±5-V supplies.

7. Maximum output swing is limited to ±5.5 V to enable the higher data rates associated with this device and to reduce EMI emissions.

8. Not more than one output should be shorted at one time.



SN75LPE185 LOW-POWER MULTIPLE RS-232 DRIVERS/RECEIVERS WITH ENABLE

SLLS256F – DECEMBER 1996 – REVISED NOVEMBER 2001

driver switching characteristics over operating free-air temperature range (unless otherwise noted)

PARAMETER		TEST CONDITIONS		MIN	TYP	MAX	UNIT
t _{PHL}	Propagation delay time, high- to low-level output	R _L = 3 kΩ to 7 kΩ,	C _L = 15 pF, See Figure 1	300	800	1600	ns
t _{PLH}	Propagation delay time, low- to high-level output	R _L = 3 kΩ to 7 kΩ,	C _L = 15 pF, See Figure 1	300	800	1600	ns
t _{PZL}	Driver output-enable time to low-level output	R _L = 3 kΩ to 7 kΩ, C _L = 15 pF	STANDBY or WAKE-UP modes, See Figures 1 and 6 and Note 7		50	100	μs
t _{PZH}	Driver output-enable time to high-level output	R _L = 3 kΩ to 7 kΩ, C _L = 15 pF	STANDBY or WAKE-UP modes, See Figures 1 and 6 and Note 7		50	100	μs
t _{PLZ}	Driver output-disable time from low-level output	R _L = 3 kΩ to 7 kΩ, C _L = 15 pF	STANDBY or WAKE-UP modes, See Figures 1 and 6 and Note 7		50	100	μs
t _{PHZ}	Driver output-disable time from high-level output	R _L = 3 kΩ to 7 kΩ, C _L = 15 pF	STANDBY or WAKE-UP modes, See Figures 1 and 6 and Note 7		50	100	μs
t _{TLH}	Transition time, low- to high-level output	V _{CC} = 5 V, V _{DD} = 12 V, V _{SS} = -12 V, R _L = 3 kΩ to 7 kΩ, See Figure 1 and Note 7	Using 10%-to-90% transition region, Driver speed = 250 kbit/s, C _L = 15 pF	375		2240	ns
			Using ±3-V transition region, Driver speed = 250 kbit/s, C _L = 15 pF	200		1500	
			Using ±2-V transition region, Driver speed = 250 kbit/s, C _L = 15 pF	133		1000	
			Using ±3-V transition region, Driver speed = 125 kbit/s, C _L = 2500 pF			2750	
t _{THL}	Transition time, high- to low-level output	V _{CC} = 5 V, V _{DD} = 12 V, V _{SS} = -12 V, R _L = 3 kΩ to 7 kΩ, See Figure 1 and Note 7	Using 10%-to-90% transition region, Driver speed = 250 kbit/s, C _L = 15 pF	375		2240	ns
			Using ±3-V transition region, Driver speed = 250 kbit/s, C _L = 15 pF	200		1500	
			Using ±2-V transition region, Driver speed = 250 kbit/s, C _L = 15 pF	133		1000	
			Using ±3-V transition region, Driver speed = 125 kbit/s, C _L = 2500 pF			2750	
SR	Output slew rate	V _{CC} = 5 V, V _{DD} = 12 V, V _{SS} = -12 V, R _L = 3 kΩ to 7 kΩ, C _L = 15 pF, See Note 7	Using ±3-V transition region, Driver speed = 0 to 250 kbit/s	4	20	30	V/μs

NOTE 7: Maximum output swing is limited to ±5.5 V to enable the higher data rates associated with this device and to reduce EMI emissions.



SN75LPE185

LOW-POWER MULTIPLE RS-232 DRIVERS/RECEIVERS WITH ENABLE

SLLS256F – DECEMBER 1996 – REVISED NOVEMBER 2001

receiver electrical characteristics over recommended operating free-air temperature range (unless otherwise noted)

PARAMETER		TEST CONDITIONS	MIN	TYP	MAX	UNIT
V_{IT+}	Positive-going input threshold voltage	See Figure 3	1.6	2	2.55	V
V_{IT-}	Negative-going input threshold voltage	See Figure 3	0.6	1	1.45	V
V_{HYS}	Input hysteresis, $V_{IT+} - V_{IT-}$	See Figure 3	600	1100		mV
V_{OH}	High-level output voltage	$I_{OH} = -1$ mA	2.5	3.9		V
V_{OL}	Low-level output voltage	$I_{OL} = 2$ mA		0.33	0.5	V
I_{IH}	High-level input current	$V_I = 3$ V	0.43	0.6	1	mA
		$V_I = 25$ V	3.6	5.1	8.3	
I_{IL}	Low-level input current	$V_I = -3$ V	-0.43	-0.6	-1	mA
		$V_I = -25$ V	-3.6	-5.1	-8.3	
$I_{OS(H)}$	Short-circuit high-level output current	$V_O = 0$, See Figure 5 and Note 8			-20	mA
$I_{OS(L)}$	Short-circuit low-level output current	$V_O = V_{CC}$, See Figure 5 and Note 8			20	mA
I_{OZ}	High-impedance output current	$V_{CC} = 0$ or 5 V, 0.3 V $\leq V_O \leq V_{CC}$			± 100	μ A
R_{IN}	Input resistance	$V_I = \pm 3$ V to ± 25 V	3	5	7	k Ω

NOTE 8: Not more than one output should be shorted at one time.

receiver switching characteristics over recommended operating free-air temperature range (unless otherwise noted)

PARAMETER		TEST CONDITIONS	MIN	TYP	MAX	UNIT
t_{PHL}	Propagation delay time, high- to low-level output	STANDBY mode $C_L = 50$ pF, See Figures 4 and 7		400	900	ns
t_{PLH}	Propagation delay time, low- to high-level output			400	900	ns
t_{TLH}	Transition time low- to high-level output			200	500	ns
t_{THL}	Transition time high- to low-level output			200	400	ns
$t_{SK(P)}$	Pulse skew $ t_{PLH} - t_{PHL} $			200	425	ns
t_{pZL}	Receiver output-enable time to low-level output			50	100	μ s
t_{pZH}	Receiver output-enable time to high-level output			50	100	μ s
t_{pLZ}	Receiver output-disable time from low-level output			50	100	μ s
t_{pHZ}	Receiver output-disable time from high-level output			50	100	μ s
t_{PHL}	Propagation delay time, high- to low-level output (WAKE-UP mode)			500	1500	ns
t_{PLH}	Propagation delay time, low- to high-level output (WAKE-UP mode)			500	1500	ns

SN75LPE185 LOW-POWER MULTIPLE RS-232 DRIVERS/RECEIVERS WITH ENABLE

SLLS256F – DECEMBER 1996 – REVISED NOVEMBER 2001

PARAMETER MEASUREMENT INFORMATION

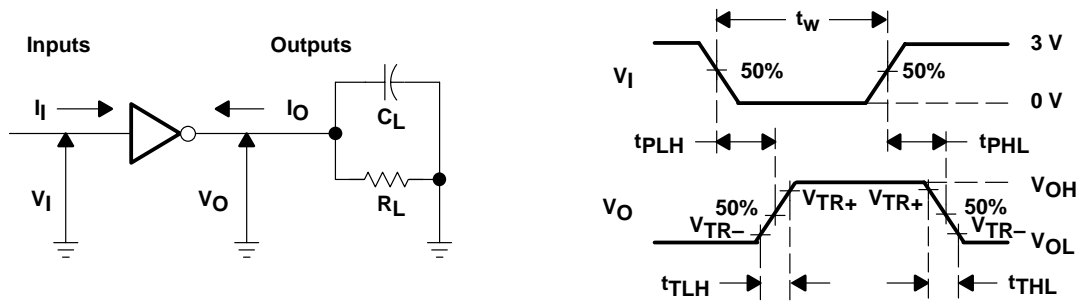

- NOTES: A. The pulse generator has the following characteristics:
 For $C_L < 1000$ pF: $t_w = 4 \mu\text{s}$, PRR = 250 kbit/s, $Z_O = 50 \Omega$, $t_r = t_f < 50$ ns.
 For $C_L = 2500$ pF: $t_w = 8 \mu\text{s}$, PRR = 125 kbit/s, $Z_O = 50 \Omega$, $t_r = t_f < 50$ ns.
 B. C_L includes probe and jig capacitance.

Figure 1. Driver Parameter Test Circuit and Waveform

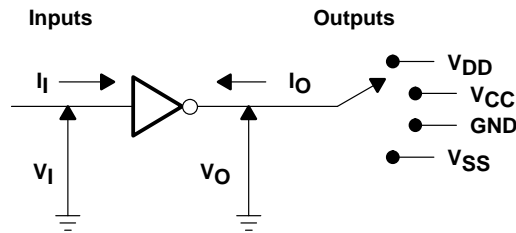

Figure 2. Driver I_{OS} Test

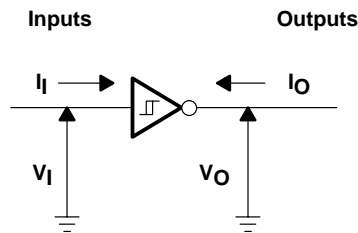
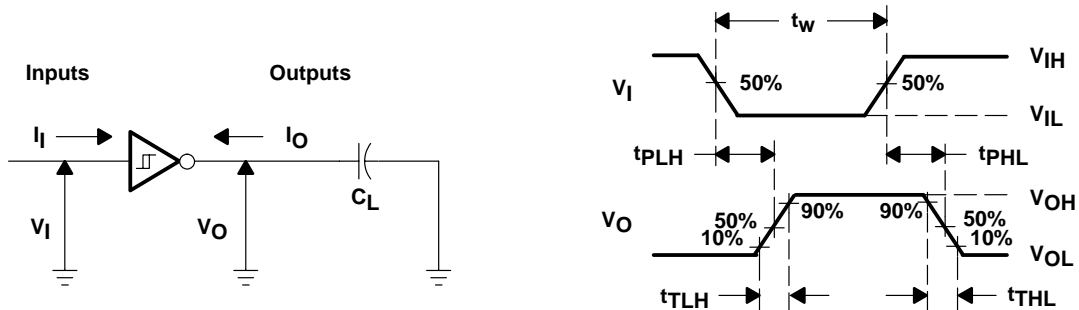

Figure 3. Receiver V_{IT} Test



- NOTES: A. The pulse generator has the following characteristics: $t_w = 4 \mu\text{s}$, PRR = 250 kbit/s, $Z_O = 50 \Omega$, $t_r = t_f < 50$ ns.
 B. C_L includes probe and jig capacitance.

Figure 4. Receiver Parameter Test Circuit and Waveform

PARAMETER MEASUREMENT INFORMATION

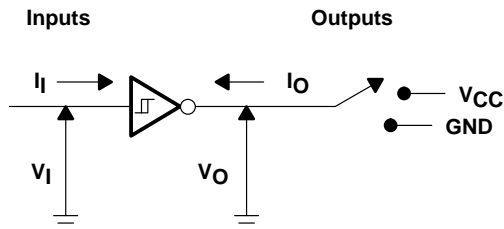
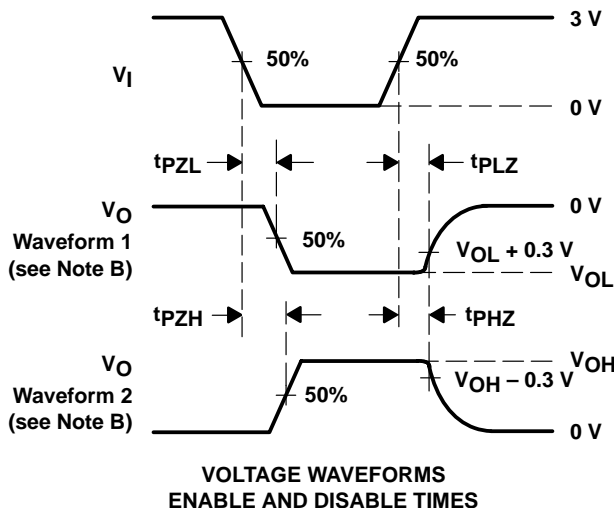
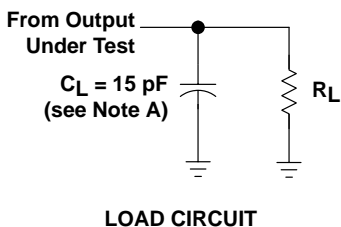

Figure 5. Receiver I_{OS} Test



- NOTES: A. C_L includes probe and jig capacitance.
 B. Waveform 1 is for an output with internal conditions such that the output is low except when disabled by the output control. Waveform 2 is for an output with internal conditions such that the output is high except when disabled by the output control.
 C. All input pulses are supplied by generators having the following characteristics: PRR = 250 kbit/s, $Z_O = 50 \Omega$, $t_r = t_f < 50$ ns.
 D. The outputs are measured one at a time with one transition per measurement.

Figure 6. Driver 3-State Parameter Load Circuit and Voltage Waveforms

SN75LPE185 LOW-POWER MULTIPLE RS-232 DRIVERS/RECEIVERS WITH ENABLE

SLLS256F – DECEMBER 1996 – REVISED NOVEMBER 2001

PARAMETER MEASUREMENT INFORMATION

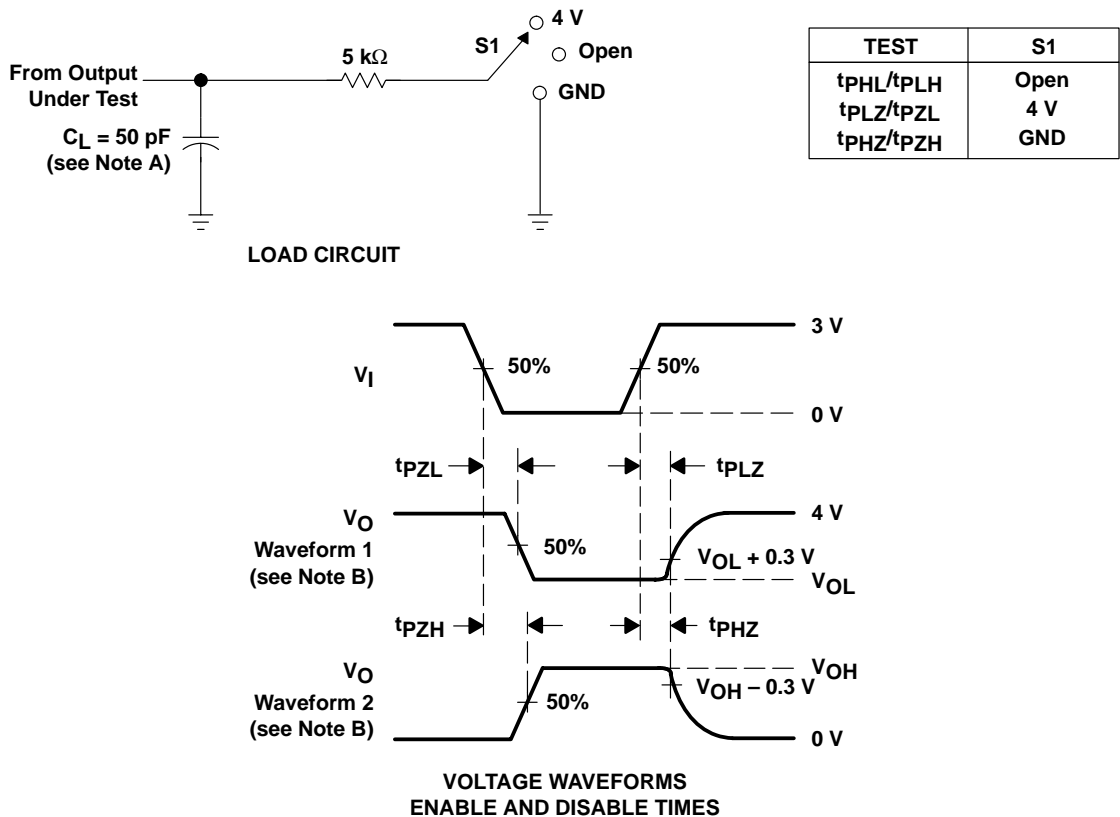

- NOTES:
- A. C_L includes probe and jig capacitance.
 - B. Waveform 1 is for an output with internal conditions such that the output is low except when disabled by the output control. Waveform 2 is for an output with internal conditions such that the output is high except when disabled by the output control.
 - C. All input pulses are supplied by generators having the following characteristics: PRR = 250 kbit/s, Z_O = 50 Ω, t_r = t_f < 50 ns.
 - D. The outputs are measured one at a time with one transition per measurement.

Figure 7. Receiver 3-State Parameter Load Circuit and Voltage Waveforms

APPLICATION INFORMATION

receiver output states

RECEIVER KNOWN OUTPUT STATES DURING POWER-DOWN, STANDBY, OR WAKE-UP MODES		
RECEIVER NUMBER	SIGNAL NAME	RECEIVER OUTPUT
RY1	$\overline{\text{DCD}}$	High
RY2	$\overline{\text{DSR}}$	High
RY3	$\overline{\text{RX}}$	Low
RY4	$\overline{\text{CTS}}$	High
RY5	$\overline{\text{RI}}$	High

fault protection during power down

Diodes placed in series with the V_{DD} and V_{SS} leads protect the SN75LPE185 in the fault condition, in which the device outputs are shorted to $\pm 15\text{ V}$ and the power supplies are at low voltage and provide low-impedance paths to ground.

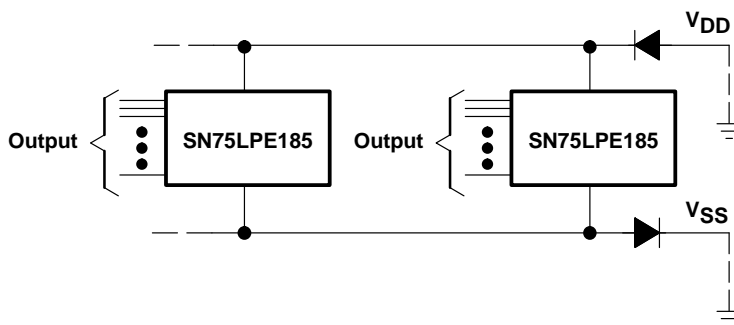

Figure 8. Power-Supply Protection to Meet Power-Off Fault Conditions of TIA/EIA-232-F

SN75LPE185 LOW-POWER MULTIPLE RS-232 DRIVERS/RECEIVERS WITH ENABLE

SLLS256F – DECEMBER 1996 – REVISED NOVEMBER 2001

APPLICATION INFORMATION

WAKE-UP mode

While in the WAKE-UP mode, all the drivers and receivers of the SN75LPE185 device are in the high-impedance state, except for receiver 5, which can be used as a ring indicator function. In this mode, the current drawn from the power supplies is low, to conserve power.

In today's PCs, board designers are becoming more concerned about power consumption. The flexibility of the SN75LPE185 during WAKE-UP mode allows the designer to operate the device at auxiliary power-supply voltages below specified levels. The SN75LPE185 functions properly during WAKE-UP mode, using the following power-supply conditions:

- (a) $V_{CC} = 4.75\text{ V}$, $V_{DD} = 9\text{ V}$, and $V_{SS} = -9\text{ V}$ (data-sheet specifications)
- (b) $V_{CC} = 5\text{ V}$, $V_{DD} = 5\text{ V}$, and $V_{SS} = -5\text{ V}$
- (c) $V_{CC} = 5\text{ V}$, $V_{DD} = \text{open}$, and $V_{SS} = \text{open}$
- (d) $V_{CC} = 5\text{ V}$, $V_{DD} = 5\text{ V}$, and V_{SS} is shorted to the most negative supply.

Condition (a) describes the minimum supply voltages necessary for the device to comply fully to specifications.

Conditions (b) and (d) describe the condition where a -5-V supply is not available during auxiliary power. In this case, V_{SS} must be shorted to the most negative supply (i.e., GND or a voltage source close to, but below GND).

Condition (c) states V_{DD} and V_{SS} power supplies can be shut off.

In all cases, GND is understood to be 0 V, and the power-supply voltages should never exceed the absolute maximum ratings.



POST OFFICE BOX 655303 • DALLAS, TEXAS 75265

PACKAGING INFORMATION

Orderable Device	Status ⁽¹⁾	Package Type	Package Drawing	Pins	Package Qty	Eco Plan ⁽²⁾	Lead/Ball Finish	MSL Peak Temp ⁽³⁾
SN75LPE185DBR	ACTIVE	SSOP	DB	24	2000	Green (RoHS & no Sb/Br)	CU NIPD	Level-1-260C-UNLIM
SN75LPE185DBRE4	ACTIVE	SSOP	DB	24	2000	Green (RoHS & no Sb/Br)	CU NIPD	Level-1-260C-UNLIM
SN75LPE185DW	ACTIVE	SOIC	DW	24	25	Green (RoHS & no Sb/Br)	CU NIPDAU	Level-1-260C-UNLIM
SN75LPE185DWE4	ACTIVE	SOIC	DW	24	25	Green (RoHS & no Sb/Br)	CU NIPDAU	Level-1-260C-UNLIM
SN75LPE185DWR	ACTIVE	SOIC	DW	24	2000	Green (RoHS & no Sb/Br)	CU NIPDAU	Level-1-260C-UNLIM
SN75LPE185DWRE4	ACTIVE	SOIC	DW	24	2000	Green (RoHS & no Sb/Br)	CU NIPDAU	Level-1-260C-UNLIM
SN75LPE185NT	ACTIVE	PDIP	NT	24	15	Pb-Free (RoHS)	CU NIPDAU	N / A for Pkg Type
SN75LPE185NTE4	ACTIVE	PDIP	NT	24	15	Pb-Free (RoHS)	CU NIPDAU	N / A for Pkg Type
SN75LPE185PWR	ACTIVE	TSSOP	PW	24	2000	Green (RoHS & no Sb/Br)	CU NIPDAU	Level-1-260C-UNLIM
SN75LPE185PWRE4	ACTIVE	TSSOP	PW	24	2000	Green (RoHS & no Sb/Br)	CU NIPDAU	Level-1-260C-UNLIM

⁽¹⁾ The marketing status values are defined as follows:

ACTIVE: Product device recommended for new designs.

LIFEBUY: TI has announced that the device will be discontinued, and a lifetime-buy period is in effect.

NRND: Not recommended for new designs. Device is in production to support existing customers, but TI does not recommend using this part in a new design.

PREVIEW: Device has been announced but is not in production. Samples may or may not be available.

OBsolete: TI has discontinued the production of the device.

⁽²⁾ Eco Plan - The planned eco-friendly classification: Pb-Free (RoHS), Pb-Free (RoHS Exempt), or Green (RoHS & no Sb/Br) - please check <http://www.ti.com/productcontent> for the latest availability information and additional product content details.

TBD: The Pb-Free/Green conversion plan has not been defined.

Pb-Free (RoHS): TI's terms "Lead-Free" or "Pb-Free" mean semiconductor products that are compatible with the current RoHS requirements for all 6 substances, including the requirement that lead not exceed 0.1% by weight in homogeneous materials. Where designed to be soldered at high temperatures, TI Pb-Free products are suitable for use in specified lead-free processes.

Pb-Free (RoHS Exempt): This component has a RoHS exemption for either 1) lead-based flip-chip solder bumps used between the die and package, or 2) lead-based die adhesive used between the die and leadframe. The component is otherwise considered Pb-Free (RoHS compatible) as defined above.

Green (RoHS & no Sb/Br): TI defines "Green" to mean Pb-Free (RoHS compatible), and free of Bromine (Br) and Antimony (Sb) based flame retardants (Br or Sb do not exceed 0.1% by weight in homogeneous material)

⁽³⁾ MSL, Peak Temp. -- The Moisture Sensitivity Level rating according to the JEDEC industry standard classifications, and peak solder temperature.

Important Information and Disclaimer:The information provided on this page represents TI's knowledge and belief as of the date that it is provided. TI bases its knowledge and belief on information provided by third parties, and makes no representation or warranty as to the accuracy of such information. Efforts are underway to better integrate information from third parties. TI has taken and continues to take reasonable steps to provide representative and accurate information but may not have conducted destructive testing or chemical analysis on incoming materials and chemicals. TI and TI suppliers consider certain information to be proprietary, and thus CAS numbers and other limited information may not be available for release.

In no event shall TI's liability arising out of such information exceed the total purchase price of the TI part(s) at issue in this document sold by TI to Customer on an annual basis.

NT (R-PDIP-T**)

PLASTIC DUAL-IN-LINE PACKAGE

24 PINS SHOWN

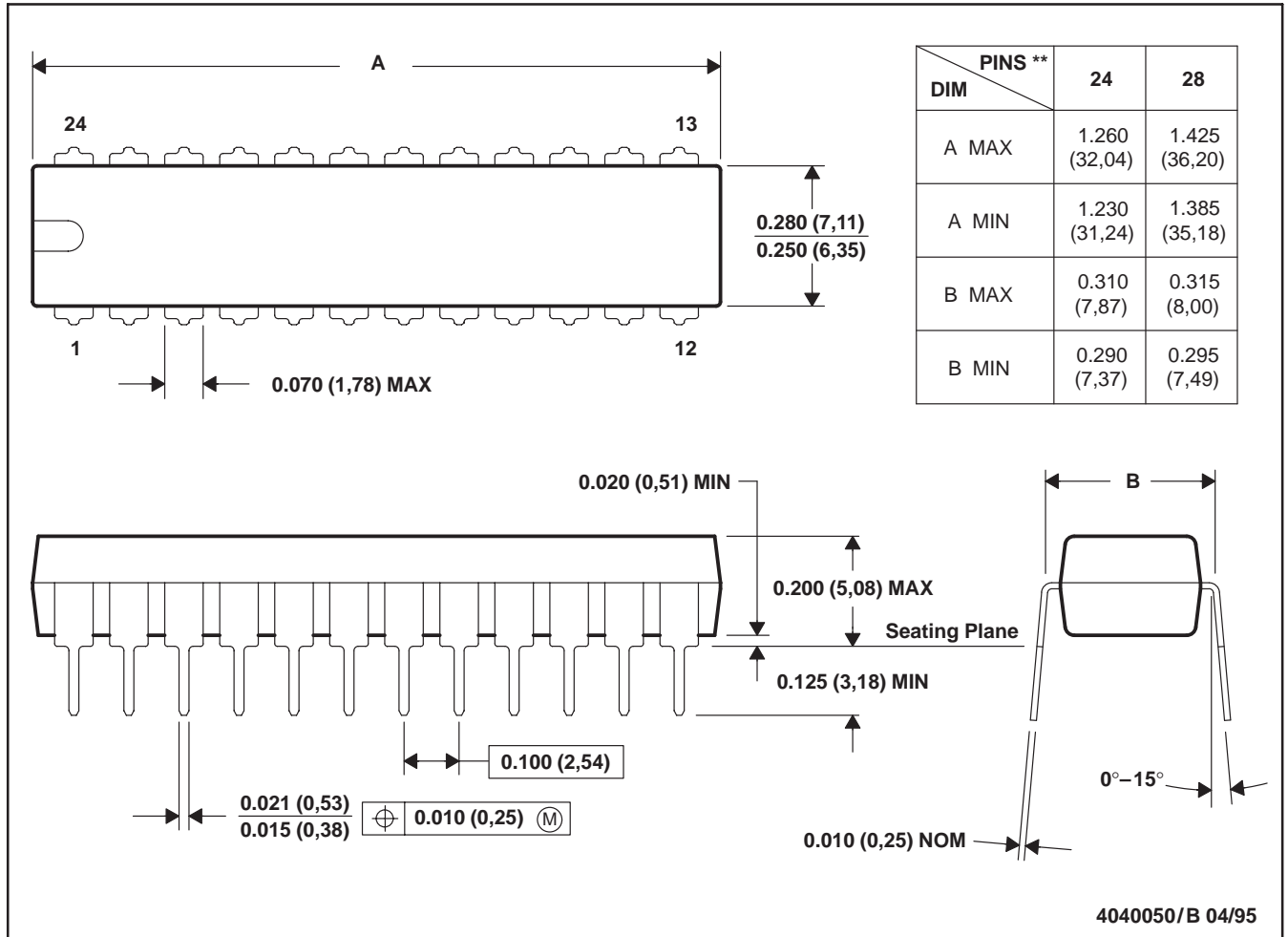

NOTES: A. All linear dimensions are in inches (millimeters).
 B. This drawing is subject to change without notice.

DB (R-PDSO-G**)

PLASTIC SMALL-OUTLINE

28 PINS SHOWN



- NOTES: A. All linear dimensions are in millimeters.
 B. This drawing is subject to change without notice.
 C. Body dimensions do not include mold flash or protrusion not to exceed 0,15.
 D. Falls within JEDEC MO-150

PW (R-PDSO-G**)

PLASTIC SMALL-OUTLINE PACKAGE

14 PINS SHOWN



4040064/F 01/97

- NOTES: A. All linear dimensions are in millimeters.
 B. This drawing is subject to change without notice.
 C. Body dimensions do not include mold flash or protrusion not to exceed 0,15.
 D. Falls within JEDEC MO-153

IMPORTANT NOTICE

Texas Instruments Incorporated and its subsidiaries (TI) reserve the right to make corrections, modifications, enhancements, improvements, and other changes to its products and services at any time and to discontinue any product or service without notice. Customers should obtain the latest relevant information before placing orders and should verify that such information is current and complete. All products are sold subject to TI's terms and conditions of sale supplied at the time of order acknowledgment.

TI warrants performance of its hardware products to the specifications applicable at the time of sale in accordance with TI's standard warranty. Testing and other quality control techniques are used to the extent TI deems necessary to support this warranty. Except where mandated by government requirements, testing of all parameters of each product is not necessarily performed.

TI assumes no liability for applications assistance or customer product design. Customers are responsible for their products and applications using TI components. To minimize the risks associated with customer products and applications, customers should provide adequate design and operating safeguards.

TI does not warrant or represent that any license, either express or implied, is granted under any TI patent right, copyright, mask work right, or other TI intellectual property right relating to any combination, machine, or process in which TI products or services are used. Information published by TI regarding third-party products or services does not constitute a license from TI to use such products or services or a warranty or endorsement thereof. Use of such information may require a license from a third party under the patents or other intellectual property of the third party, or a license from TI under the patents or other intellectual property of TI.

Reproduction of information in TI data books or data sheets is permissible only if reproduction is without alteration and is accompanied by all associated warranties, conditions, limitations, and notices. Reproduction of this information with alteration is an unfair and deceptive business practice. TI is not responsible or liable for such altered documentation.

Resale of TI products or services with statements different from or beyond the parameters stated by TI for that product or service voids all express and any implied warranties for the associated TI product or service and is an unfair and deceptive business practice. TI is not responsible or liable for any such statements.

Following are URLs where you can obtain information on other Texas Instruments products and application solutions:

Products		Applications	
Amplifiers	amplifier.ti.com	Audio	www.ti.com/audio
Data Converters	dataconverter.ti.com	Automotive	www.ti.com/automotive
DSP	dsp.ti.com	Broadband	www.ti.com/broadband
Interface	interface.ti.com	Digital Control	www.ti.com/digitalcontrol
Logic	logic.ti.com	Military	www.ti.com/military
Power Mgmt	power.ti.com	Optical Networking	www.ti.com/opticalnetwork
Microcontrollers	microcontroller.ti.com	Security	www.ti.com/security
Low Power Wireless	www.ti.com/lpw	Telephony	www.ti.com/telephony
		Video & Imaging	www.ti.com/video
		Wireless	www.ti.com/wireless

Mailing Address: Texas Instruments
Post Office Box 655303 Dallas, Texas 75265