

## High Power PIN Diode 50 MHz - 12 GHz

Rev. V1

### Features

- 3 Terminal LPF Broadband Shunt Structure
- 50 MHz - 12 GHz Broadband Frequency
- >100 W Peak Power Handling
- < 0.1 dB Shunt Insertion Loss
- > 25 dB Shunt Isolation
- < 20°C/W Thermal Resistance
- Lead-Free 1.5 x 1.2 mm 6-lead DFN Package
- RoHS\* Compliant and 260°C Reflow

### Description

The MADP-011029 is a lead-free 1.5 x 1.2 mm DFN surface mount plastic packaged that provides both low and high signal frequency operation from 50 MHz to 12 GHz. The higher breakdown voltage and lower thermal resistance of the PIN diode provides peak power handling in excess of 100 W.

This device is ideally suitable for usage in higher incident power switches, phase shifters, attenuators, and limiter microwave circuits over a broad frequency where higher performance surface mount diode assemblies are required.

### Ordering Information<sup>1,2</sup>

Part Number	Package
MADP-011029-14150T	3000 piece reel
MADP-011029-000SMB	Sample board

1. Reference Application Note [M513](#) for reel size information.
2. All RF Sample boards include 5 loose parts.

### Functional Schematic

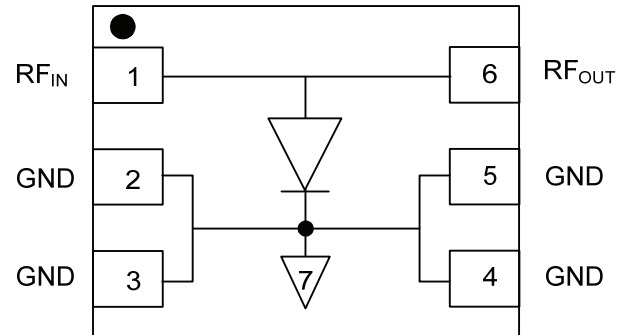

### Pin Configuration<sup>3</sup>

Pin No.	Pin Name	Description
1	RF <sub>IN</sub>	RF Input
2	GND	Ground
3	GND	Ground
4	GND	Ground
5	GND	Ground
6	RF <sub>OUT</sub>	RF Output
7	Paddle <sup>4</sup>	Ground

3. M/A-COM Technology Solutions recommends connecting unused package pins to ground.
4. The exposed pad centered on the package bottom must be connected to RF, DC, and thermal ground.

\* Restrictions on Hazardous Substances, European Union Directive 2002/95/EC.

**High Power PIN Diode**  
**50 MHz - 12 GHz**

Rev. V1

**Electrical Specifications:  $T_A = +25^\circ\text{C}$** 

Parameter	Test Conditions	Units	Min.	Typ.	Max.
Forward Voltage	+ 50 mA D.C.	V	0.7	0.9	1.1
Reverse Leakage Current	-200 V D.C.	$\eta\text{A}$	—	- 20	-1000
Total Capacitance <sup>5</sup>	-50 V @ 1 GHz	pF	—	0.31	0.40
Series Resistance <sup>6</sup>	+10 mA @ 1 GHz	$\Omega$	—	1.5	1.9
Parallel Resistance <sup>6</sup>	-Vdc = -40 V, @ 100 MHz	K $\Omega$	—	1000	—
Minority Carrier Lifetime	+If = 10 mA / -Ir = -6 mA (50% Control Voltage, 90% Output Voltage)	$\mu\text{S}$	—	1.0	2.0
C.W. Thermal Resistance ( Infinite Heat Sink at Thermal Ground Plane)	IHigh = 4 A, Ilow = 10 mA @ 10 kHz	$^\circ\text{C}/\text{W}$	—	20	—
Power Dissipation <sup>7,8</sup> ( Infinite Heat Sink at Thermal Ground Plane)	+If = 50 mA @ 1 GHz	W	—	7.5	—
Insertion Loss	F = 1 GHz, -Vdc = -10V	dB		-0.1	
Isolation	F = 1 GHz, +Ibias = +10 mA	dB		-25	-23

5.  $C_t$  ( Total Capacitance ) =  $C_j$  ( Junction Capacitance ) +  $C_p$  ( Parasitic Package Capacitance ).

6.  $R_s$  and  $R_p$  are measured on an HP4291A Impedance Analyzer.

7. De-rate power dissipation linearly by  $-50\text{ mW}/^\circ\text{C}$  to 0 W @  $+175^\circ\text{C}$ :  $P_d(T) = P_d(+25^\circ\text{C}) - \Delta P = P_d(+25^\circ\text{C}) - (50\text{ mW}/^\circ\text{C})(\Delta T)$ .

8.  $PD = \Delta T_j / \Theta$  or  $PD = (I_F + I_{RF})^2 (R_s)$ , where  $I_F$  is the forward bias DC current and  $I_{RF}$  is the forward bias RMS RF current.

**Absolute Maximum Ratings<sup>9,10</sup>**

Parameter	Absolute Maximum
D.C. Forward Voltage @ +250 mA	1.2 V
D.C. Forward Current	250 mA
D.C. Reverse Voltage	-400V
Junction Temperature <sup>11</sup>	+175 $^\circ\text{C}$
Operating Temperature	-65 $^\circ\text{C}$ to +125 $^\circ\text{C}$
Storage Temperature	-65 $^\circ\text{C}$ to +150 $^\circ\text{C}$
Re-flow Temperature	+260 $^\circ\text{C}$ for 360 seconds

9. Exceeding any one or combination of these limits may cause permanent damage to this device.

10. M/A-COM Technology Solutions does not recommend sustained operation near these survivability limits.

11. Operating at nominal conditions with  $T_j \leq +140^\circ\text{C}$  will ensure  $MTTF > 1 \times 10^6$  hours.

**Handling Procedures**

Please observe the following precautions to avoid damage:

**Static Sensitivity**

These devices are sensitive to electrostatic discharge (ESD) and can be damaged by static electricity. Proper ESD control techniques should be used when handling these Class 2 devices.

High Power PIN Diode  
50 MHz - 12 GHz

Rev. V1

## PCB Layout

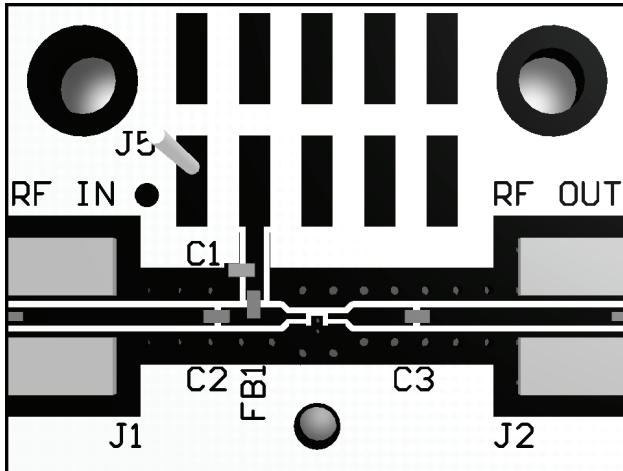

## PCB Schematic

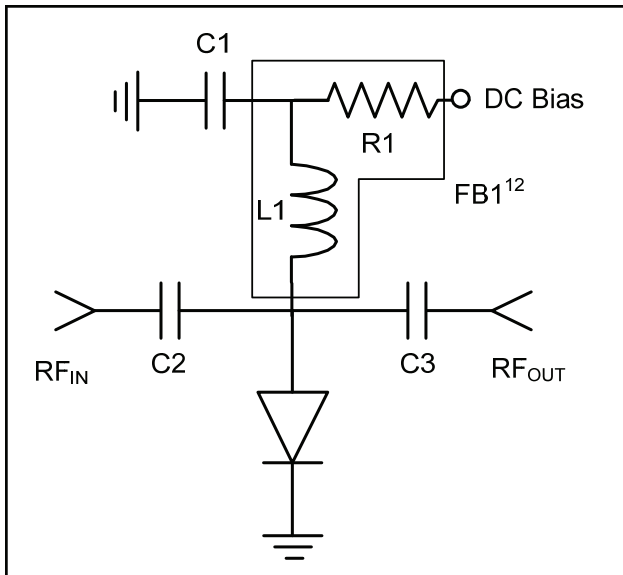

12. R1 is not needed when using the recommended ferrite FB1.

## 500 - 5000 MHz Parts List<sup>13</sup>

Part	Value	Case Style
C1	62 pF	0402
C2, C3	100 pF	0402
FB1	470 $\Omega$ @ 1 GHz	0402
R1	150 $\Omega$	0402
L1	82 nH	0402

13. Max DC voltage with recommended components not to exceed 100 V.

## Assembly Recommendations

Devices may be soldered using standard Pb60/Sn40, or RoHS compliant solders. Leads are plated NiPdAuAg to ensure an optimum solderable connection.

For recommended Sn/Pb and RoHS soldering profile See Application Note [M538](#) on the MACOM website.

## Cleanliness and Storage

These devices should be handled and stored in a clean environment. Ends of the device are NiPdAuAg plated for greater solderability. Exposure to high humidity (>80%) for extended periods may cause the surface to oxidize. Caution should be taken when storing devices for long periods.

## General Handling

Device can be handled with tweezers or vacuum pickups and are suitable for use with automatic pick-and-place equipment.

## Typical 1 GHz Parametric Curves

**Series Resistance vs. Forward Current**

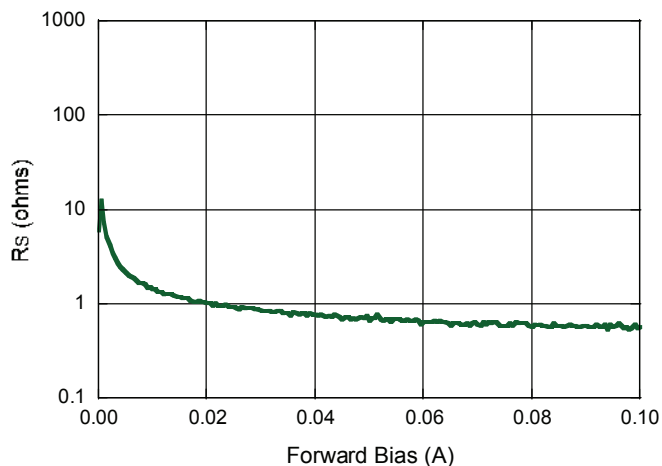

**Capacitance vs. Reverse Voltage**

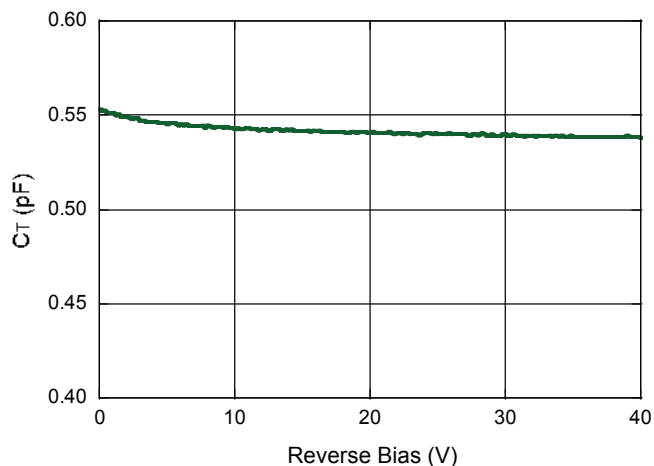

**Parallel Resistance vs. Reverse Voltage**

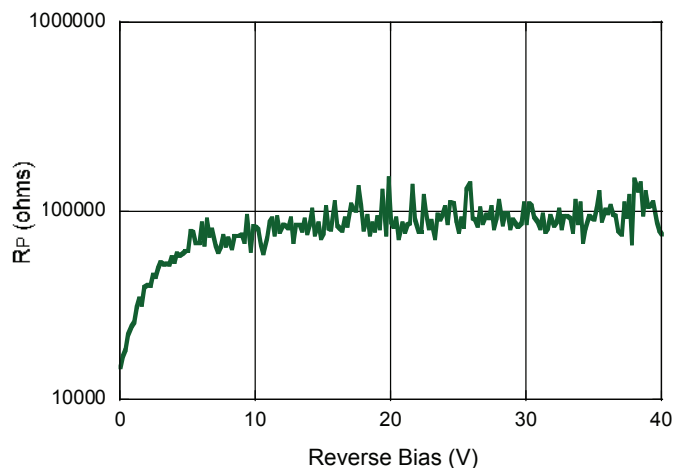

## Typical RF Small Signal Performance Curves

**Insertion Loss**

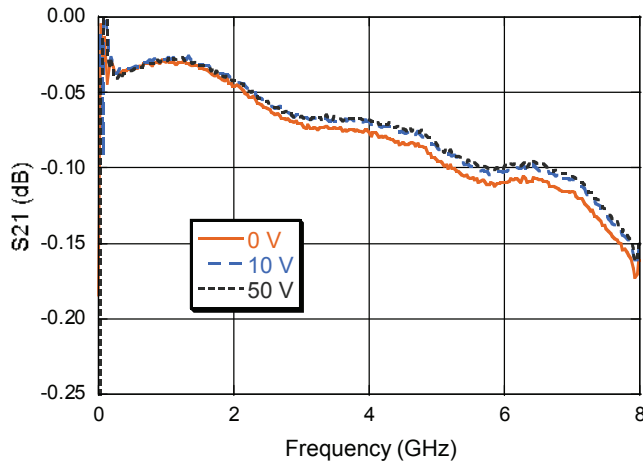

**Return Loss**

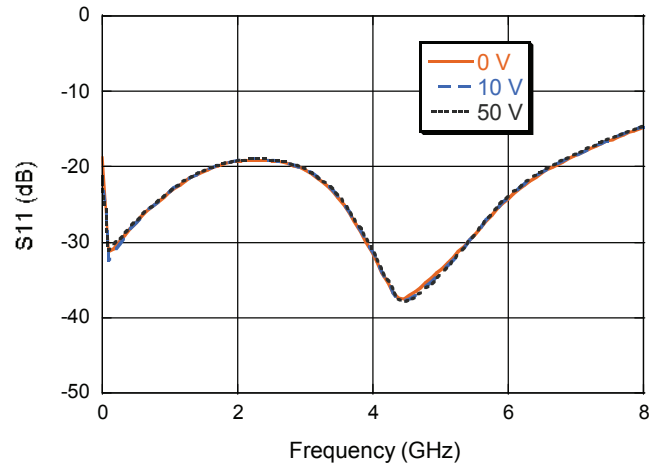

**Isolation**

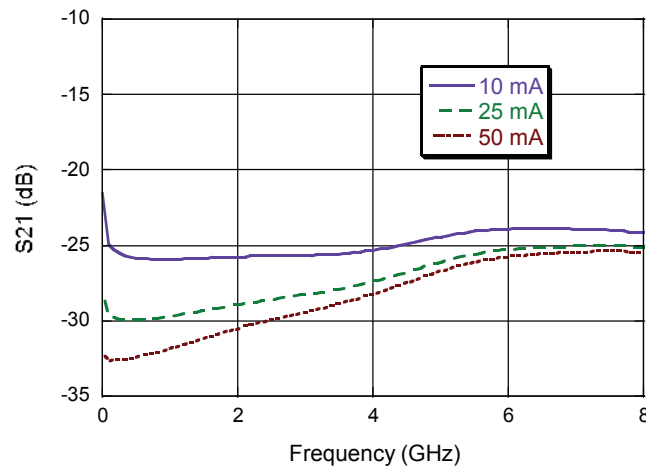

# MADP-011029-14150T

High Power PIN Diode  
50 MHz - 12 GHz

Rev. V1

## Lead-Free 1.5 x 1.2 mm 6-Lead DFN<sup>†</sup>

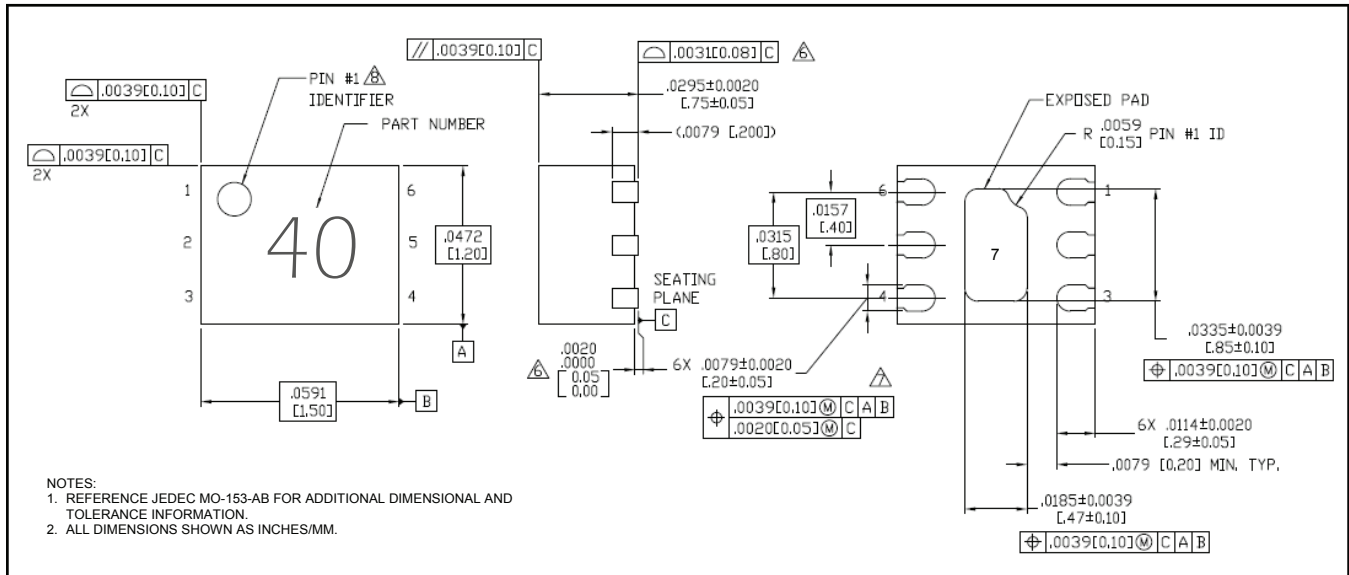

<sup>†</sup> Reference Application Note [S2083](#) for lead-free solder reflow recommendations.  
Meets JEDEC moisture sensitivity level 1 requirements.  
Plating is NiPdAuAg

## Applications Section

**Schematic of High Power SP2T Shunt Switch using MADP-011029-14150T PIN Diodes**  
**F = Octave Bandwidth from 1 to 12 GHz**  
**P<sub>inc</sub> = +40 dBm CW**  
**P<sub>inc</sub> = +50 dBm, 10 μS PW, 1 % Duty**

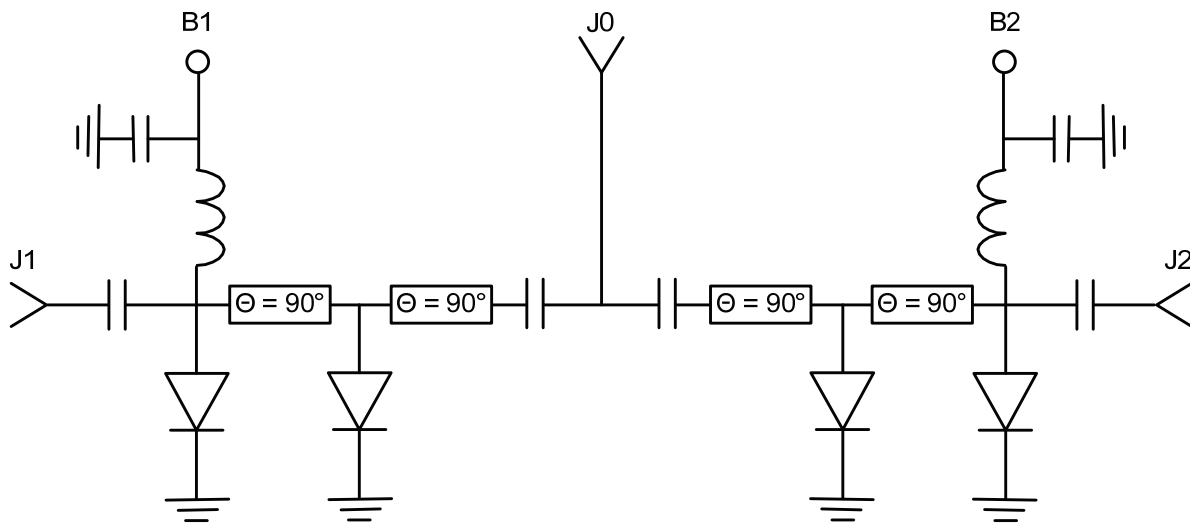

$$L = 11.807 / (\epsilon_{\text{eff}}^{1/2} * F * 4) \text{ inches, } \theta = \beta * L = (2 \pi / \lambda) * L = 90^\circ$$

Frequency is in GHz,  $\epsilon_{\text{eff}}$  is Effective Dielectric Constant of Transmission Line Medium

RF State	B1 Bias	B2 Bias
J0-J1 Low Loss & J0-J2 Isolation	-50 V @ 0 mA	+1 V @ +20 mA
J0-J2 Low Loss & J0-J1 Isolation	+1 V @ +20 mA	-50 V @ 0 mA

## Applications Section

**Schematic of 3 Stage Limiter using MADP-011029-14150T**  
 **$F = 1000 - 8,000 \text{ MHz}$**   
 **$P_{inc} = +47 \text{ dBm CW}$**   
 **$P_{inc} = +50 \text{ dBm, } 10 \mu\text{S P.W., } 1 \% \text{ Duty}$**

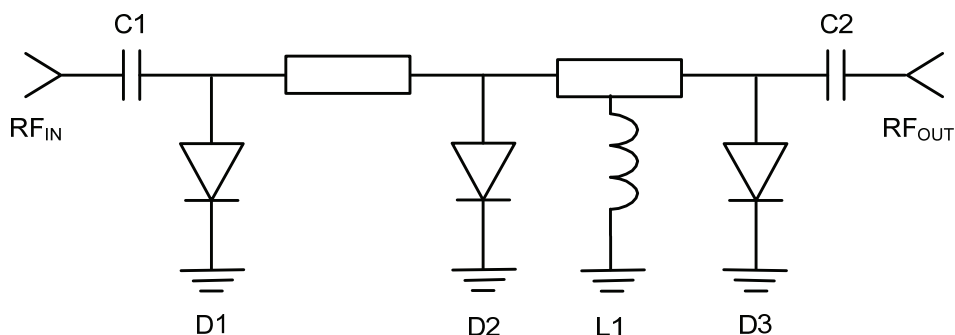

Part	PN	Case Style	Description	Quantity
D1	MADP-011029-14150T	ODS-1415	Input PIN Diode	1
D2	MADP-011023-14150T	ODS-1415	2nd Stage PIN Diode	1
D3	MADP-011023-14150T	ODS-1415	3rd Stage PIN Diode	1
L1	33 nH	0402	RF Choke / DC Return	1
C1	27 pF	0402	DC Block	1
C2	27 pF	0402	DC Block	1



High Power PIN Diode  
50 MHz - 12 GHz

Rev. V1

### Microwave Model of MADP-011027-14150T

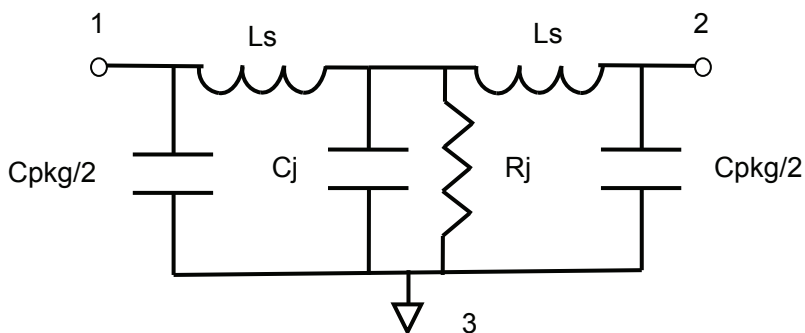
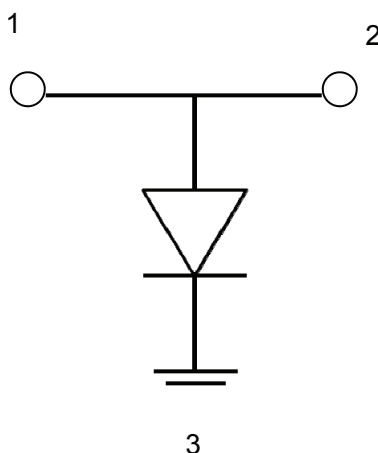

$R_j = R_s$  ( Forward Bias Current )  
 $R_j = R_p$  ( Reverse Bias Voltage )

Parameter	Value
Cpackage	8.0E-14 F
Lbond=Ls	4.0E-10 H
Rs	0.9 $\Omega$
Rp	5E+5 $\Omega$