

# LM2590HV

## SIMPLE SWITCHER® Power Converter 150 kHz 1A Step-Down Voltage Regulator, with Features

### General Description

The LM2590HV series of regulators are monolithic integrated circuits that provide all the active functions for a step-down (buck) switching regulator, capable of driving a 1A load with excellent line and load regulation. These devices are available in fixed output voltages of 3.3V, 5V, and an adjustable output version.

This series of switching regulators is similar to the LM2591HV with additional supervisory and performance features.

Requiring a minimum number of external components, these regulators are simple to use and include internal frequency compensation†, improved line and load specifications, fixed-frequency oscillator, Shutdown/Soft-start, output error flag and flag delay.

The LM2590HV operates at a switching frequency of 150 kHz thus allowing smaller sized filter components than what would be needed with lower frequency switching regulators. Available in a standard 7-lead TO-220 package with several different lead bend options, and a 7-lead TO-263 Surface mount package.

Other features include a guaranteed  $\pm 4\%$  tolerance on output voltage under all conditions of input voltage and output load conditions, and  $\pm 15\%$  on the oscillator frequency. External shutdown is included, featuring typically 90  $\mu\text{A}$  standby current. Self protection features include a two stage current limit for the output switch and an over temperature shutdown for complete protection under fault conditions.

### Features

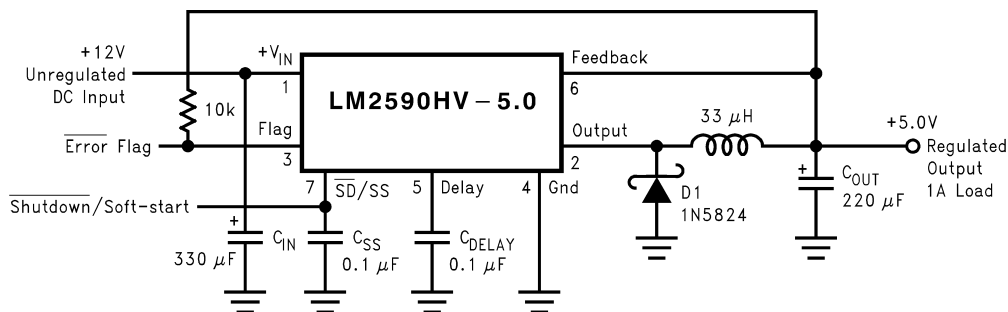
- 3.3V, 5V, and adjustable output versions
- Adjustable version output voltage range, 1.2V to 57V  $\pm 4\%$  max over line and load conditions
- Guaranteed 1A output load current
- Available in 7-pin TO-220 and TO-263 (surface mount) Package
- Input voltage range up to 60V
- 150 kHz fixed frequency internal oscillator
- Shutdown/Soft-start
- Out of regulation error flag
- Error flag delay
- Low power standby mode,  $I_Q$  typically 90  $\mu\text{A}$
- High Efficiency
- Thermal shutdown and current limit protection

### Applications

- Simple high-efficiency step-down (buck) regulator
- Efficient pre-regulator for linear regulators
- On-card switching regulators
- Positive to Negative converter

Note: † Patent Number 5,382,918.

### Typical Application (Fixed Output Voltage Versions)



10134701

**Absolute Maximum Ratings** (Note 1)

If Military/Aerospace specified devices are required, please contact the National Semiconductor Sales Office/Distributors for availability and specifications.

Maximum Supply Voltage ( $V_{IN}$ )	63V
$\overline{SD}$ /SS Pin Input Voltage (Note 2)	6V
Delay Pin Voltage (Note 2)	1.5V
Flag Pin Voltage	$-0.3 \leq V \leq 45V$
Feedback Pin Voltage	$-0.3 \leq V \leq +25V$
Output Voltage to Ground (Steady State)	-1V
Power Dissipation	Internally limited
Storage Temperature Range	$-65^{\circ}C$ to $+150^{\circ}C$

## ESD Susceptibility

Human Body Model (Note 3)	2 kV
Lead Temperature	
S Package	
Vapor Phase (60 sec.)	$+215^{\circ}C$
Infrared (10 sec.)	$+245^{\circ}C$
T Package (Soldering, 10 sec.)	$+260^{\circ}C$
Maximum Junction Temperature	$+150^{\circ}C$

**Operating Conditions**

Temperature Range	$-40^{\circ}C \leq T_J \leq +125^{\circ}C$
Supply Voltage	4.5V to 60V

**LM2590HV-3.3  
Electrical Characteristics**

Specifications with standard type face are for  $T_J = 25^{\circ}C$ , and those with **boldface type** apply over **full Operating Temperature Range**.

Symbol	Parameter	Conditions	LM2590HV-3.3		Units (Limits)
			Typ (Note 4)	Limit (Note 5)	
<b>SYSTEM PARAMETERS</b> (Note 6) Test Circuit <i>Figure 1</i>					
$V_{OUT}$	Output Voltage	$4.75V \leq V_{IN} \leq 60V$ , $0.2A \leq I_{LOAD} \leq 1A$	3.3	3.168/ <b>3.135</b> 3.432/ <b>3.465</b>	V V(min) V(max)
$\eta$	Efficiency	$V_{IN} = 12V$ , $I_{LOAD} = 1A$	77		

**LM2590HV-5.0  
Electrical Characteristics**

Specifications with standard type face are for  $T_J = 25^{\circ}C$ , and those with **boldface type** apply over **full Operating Temperature Range**.

Symbol	Parameter	Conditions	LM2590HV-5.0		Units (Limits)
			Typ (Note 4)	Limit (Note 5)	
<b>SYSTEM PARAMETERS</b> (Note 6) Test Circuit <i>Figure 1</i>					
$V_{OUT}$	Output Voltage	$7V \leq V_{IN} \leq 60V$ , $0.2A \leq I_{LOAD} \leq 1A$	5	4.800/ <b>4.750</b> 5.200/ <b>5.250</b>	V V(min) V(max)
$\eta$	Efficiency	$V_{IN} = 12V$ , $I_{LOAD} = 1A$	82		%

**LM2590HV-ADJ  
Electrical Characteristics**

Specifications with standard type face are for  $T_J = 25^{\circ}C$ , and those with **boldface type** apply over **full Operating Temperature Range**.

Symbol	Parameter	Conditions	LM2590HV-ADJ		Units (Limits)
			Typ (Note 4)	Limit (Note 5)	
<b>SYSTEM PARAMETERS</b> (Note 6) Test Circuit <i>Figure 1</i>					
$V_{FB}$	Feedback Voltage	$4.5V \leq V_{IN} \leq 60V$ , $0.2A \leq I_{LOAD} \leq 1A$ $V_{OUT}$ programmed for 3V. Circuit of <i>Figure 1</i> .	1.230	1.193/ <b>1.180</b> 1.267/ <b>1.280</b>	V V(min) V(max)



## All Output Voltage Versions

### Electrical Characteristics (Continued)

Specifications with standard type face are for  $T_J = 25^\circ\text{C}$ , and those with **boldface type** apply over **full Operating Temperature Range**. Unless otherwise specified,  $V_{IN} = 12\text{V}$  for the 3.3V, 5V, and Adjustable version.  $I_{LOAD} = 500\text{ mA}$

Symbol	Parameter	Conditions	LM2590HV-XX		Units (Limits)
			Typ (Note 4)	Limit (Note 5)	
<b>FLAG/DELAY CONTROL</b> Test Circuit of <i>Figure 1</i>					
	Regulator Dropout Detector Threshold Voltage	Low (Flag ON)	96	92 98	% %(min) %(max)
$V_{FSAT}$	Flag Output Saturation Voltage	$I_{SINK} = 3\text{ mA}$ $V_{DELAY} = 0.5\text{V}$	0.3	<b>0.7/1.0</b>	V V(max)
$I_{FL}$	Flag Output Leakage Current	$V_{FLAG} = 60\text{V}$	0.3		$\mu\text{A}$
	Delay Pin Threshold Voltage	Low (Flag ON) High (Flag OFF) and $V_{OUT}$ Regulated	1.25	1.21 1.29	V V(min) V(max)
	Delay Pin Source Current	$V_{DELAY} = 0.5\text{V}$	3	6	$\mu\text{A}$ $\mu\text{A(max)}$
	Delay Pin Saturation	Low (Flag ON)	70	<b>350/400</b>	mV mV(max)

**Note 1:** Absolute Maximum Ratings indicate limits beyond which damage to the device may occur. Operating Ratings indicate conditions for which the device is intended to be functional, but do not guarantee specific performance limits. For guaranteed specifications and test conditions, see the Electrical Characteristics.

**Note 2:** Voltage internally clamped. If clamp voltage is exceeded, limit current to a maximum of 1 mA.

**Note 3:** The human body model is a 100 pF capacitor discharged through a 1.5k resistor into each pin.

**Note 4:** Typical numbers are at  $25^\circ\text{C}$  and represent the most likely norm.

**Note 5:** All limits guaranteed at room temperature (standard type face) and at **temperature extremes (bold type face)**. All room temperature limits are 100% production tested. All limits at **temperature extremes** are guaranteed via correlation using standard Statistical Quality Control (SQC) methods. All limits are used to calculate Average Outgoing Quality Level (AOQL).

**Note 6:** External components such as the catch diode, inductor, input and output capacitors can affect switching regulator system performance. When the LM2590HV is used as shown in the *Figure 1* test circuit, system performance will be as shown in system parameters section of Electrical Characteristics.

**Note 7:** The switching frequency is reduced when the second stage current limit is activated. The amount of reduction is determined by the severity of current overload.

**Note 8:** No diode, inductor or capacitor connected to output pin.

**Note 9:** Feedback pin removed from output and connected to 0V to force the output transistor switch ON.

**Note 10:** Feedback pin removed from output and connected to 12V for the 3.3V, 5V, and the ADJ. version to force the output transistor switch OFF.

**Note 11:**  $V_{IN} = 60\text{V}$ .

**Note 12:** Junction to ambient thermal resistance (no external heat sink) for the package mounted TO-220 package mounted vertically, with the leads soldered to a printed circuit board with (1 oz.) copper area of approximately  $1\text{ in}^2$ .

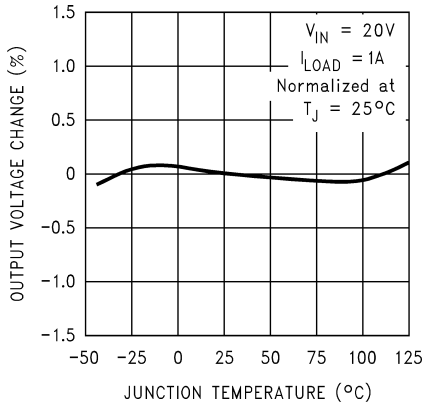
**Note 13:** Junction to ambient thermal resistance with the TO-263 package tab soldered to a single sided printed circuit board with  $0.5\text{ in}^2$  of (1 oz.) copper area.

**Note 14:** Junction to ambient thermal resistance with the TO-263 package tab soldered to a single sided printed circuit board with  $2.5\text{ in}^2$  of (1 oz.) copper area.

**Note 15:** Junction to ambient thermal resistance with the TO-263 package tab soldered to a double sided printed circuit board with  $3\text{ in}^2$  of (1 oz.) copper area on the LM2590HVS side of the board, and approximately  $16\text{ in}^2$  of copper on the other side of the p-c board. See application hints in this data sheet and the thermal model in **Switchers Made Simple** available at <http://power.national.com>.

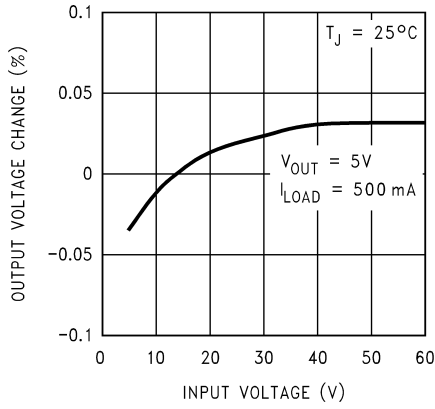
# Typical Performance Characteristics (Circuit of Figure 1)

**Normalized Output Voltage**



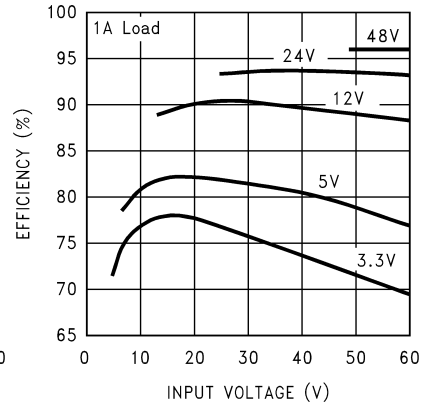
10134702

**Line Regulation**



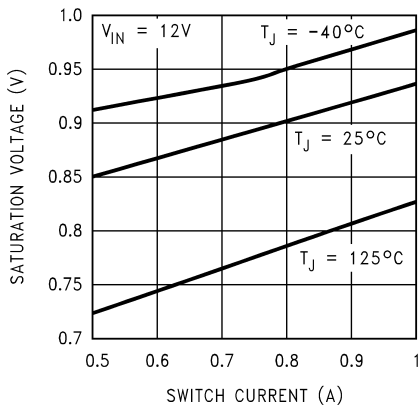
10134703

**Efficiency**



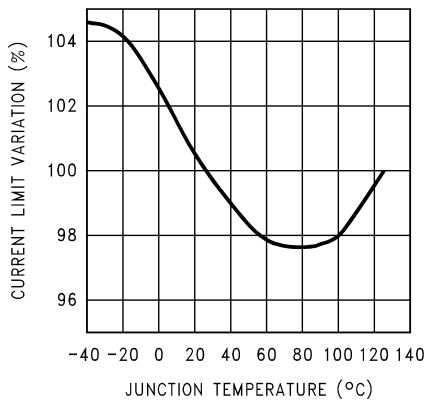
10134704

**Switch Saturation Voltage**



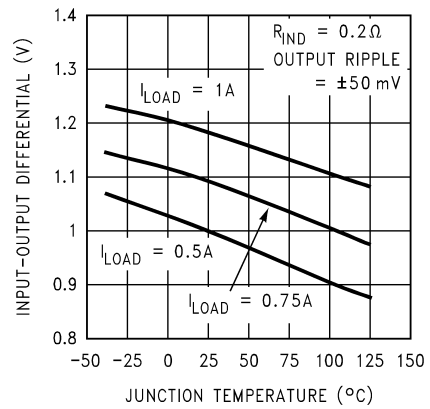
10134705

**Switch Current Limit**



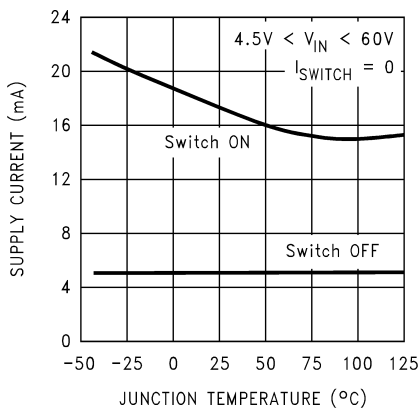
10134706

**Dropout Voltage**



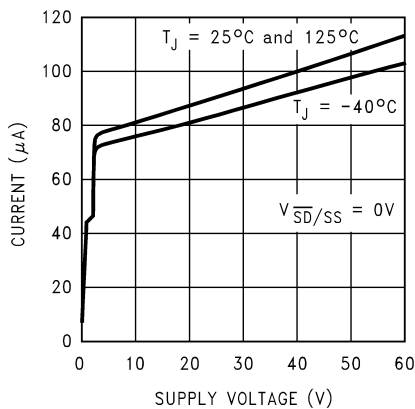
10134707

**Operating Quiescent Current**



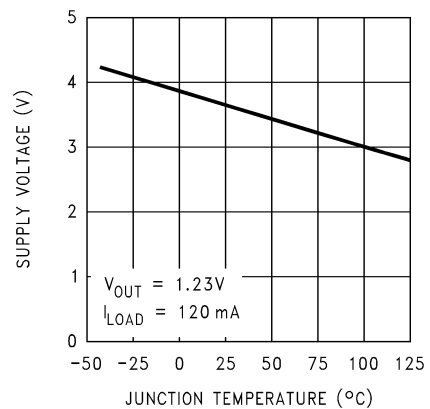
10134708

**Shutdown Quiescent Current**



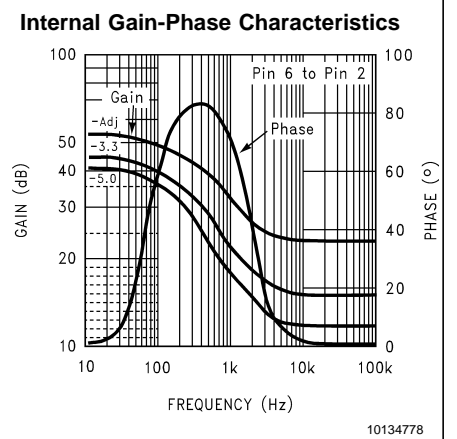
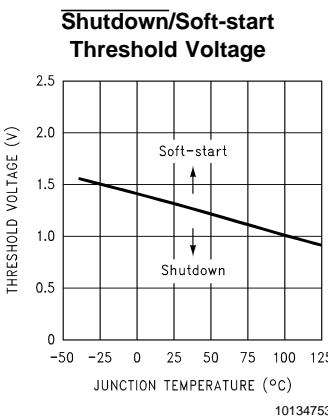
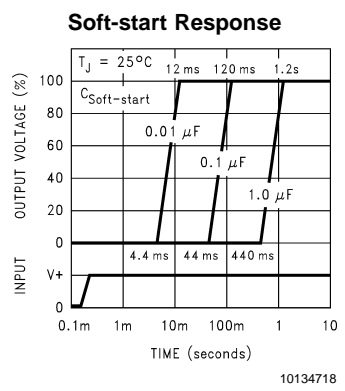
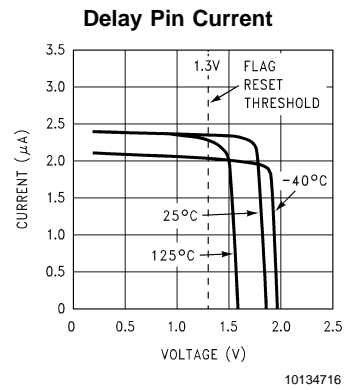
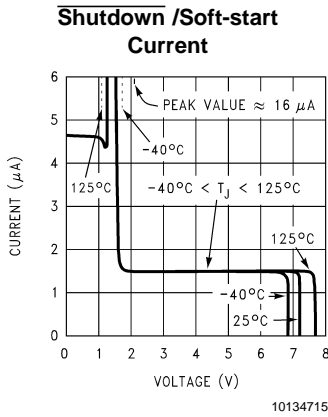
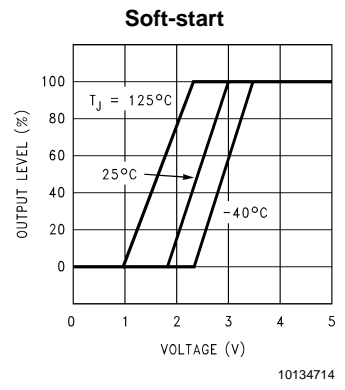
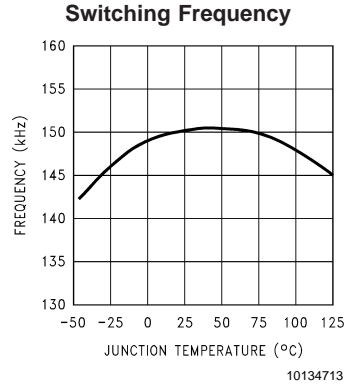
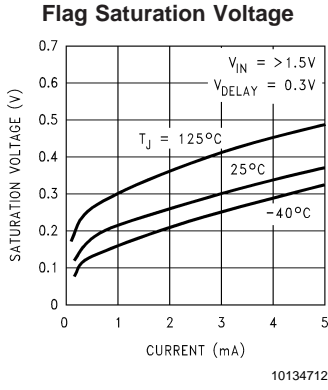
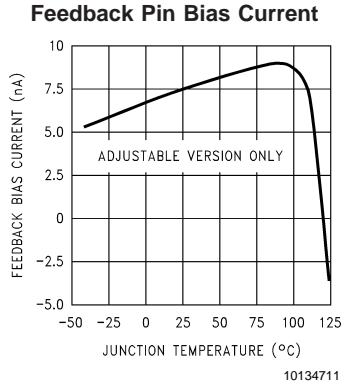
10134709

**Minimum Operating Supply Voltage**



10134710

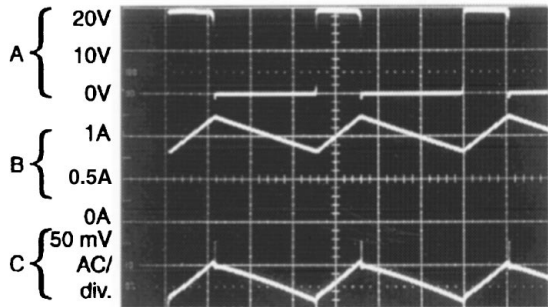
Typical Performance Characteristics (Circuit of Figure 1) (Continued)



## Typical Performance Characteristics (Circuit of Figure 1) (Continued)

### Continuous Mode Switching Waveforms

$V_{IN} = 20V, V_{OUT} = 5V, I_{LOAD} = 1A$   
 $L = 52 \mu H, C_{OUT} = 100 \mu F, C_{OUT} ESR = 100 m\Omega$



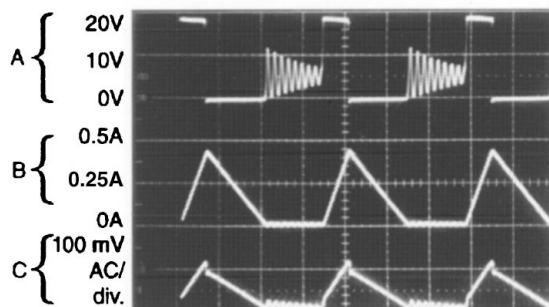
10134720

Horizontal Time Base: 2  $\mu s/div.$

- A: Output Pin Voltage, 10V/div.
- B: Inductor Current 0.5A/div.
- C: Output Ripple Voltage, 50 mV/div.

### Discontinuous Mode Switching Waveforms

$V_{IN} = 20V, V_{OUT} = 5V, I_{LOAD} = 250 mA$   
 $L = 15 \mu H, C_{OUT} = 150 \mu F, C_{OUT} ESR = 90 m\Omega$



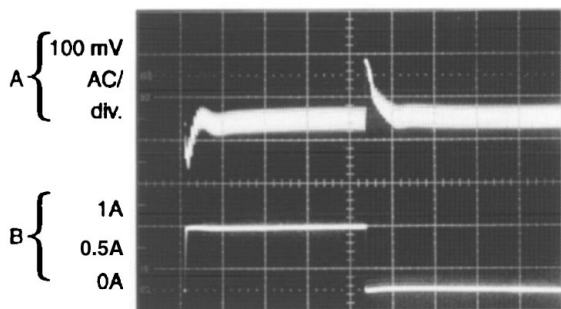
10134719

Horizontal Time Base: 2  $\mu s/div.$

- A: Output Pin Voltage, 10V/div.
- B: Inductor Current 0.25A/div.
- C: Output Ripple Voltage, 100 mV/div.

### Load Transient Response for Continuous Mode

$V_{IN} = 20V, V_{OUT} = 5V, I_{LOAD} = 250 mA \text{ to } 1A$   
 $L = 52 \mu H, C_{OUT} = 100 \mu F, C_{OUT} ESR = 100 m\Omega$



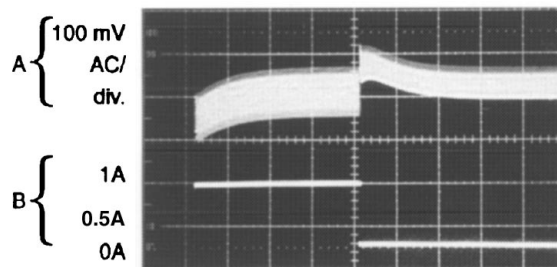
10134721

Horizontal Time Base: 50  $\mu s/div.$

- A: Output Voltage, 100 mV/div. (AC)
- B: 250 mA to 1A Load Pulse

### Load Transient Response for Discontinuous Mode

$V_{IN} = 20V, V_{OUT} = 5V, I_{LOAD} = 250 mA \text{ to } 1A$   
 $L = 15 \mu H, C_{OUT} = 150 \mu F, C_{OUT} ESR = 90 m\Omega$



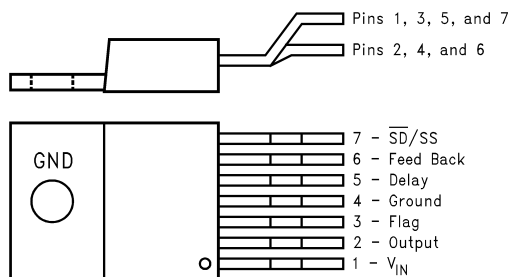
10134722

Horizontal Time Base: 200  $\mu s/div.$

- A: Output Voltage, 100 mV/div. (AC)
- B: 250 mA to 1A Load Pulse

## Connection Diagrams and Order Information

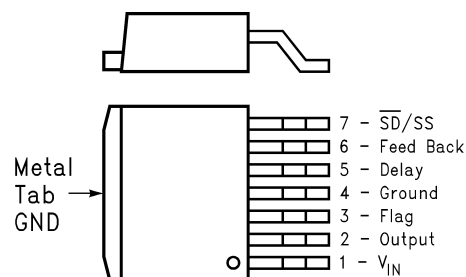
### Bent and Staggered Leads, Through Hole Package 7-Lead TO-220 (T)



10134750

Order Number **LM2590HVT-3.3, LM2590HVT-5.0,**  
 or **LM2590HVT-ADJ**  
 See NS Package Number **TA07B**

### Surface Mount Package 7-Lead TO-263 (S)

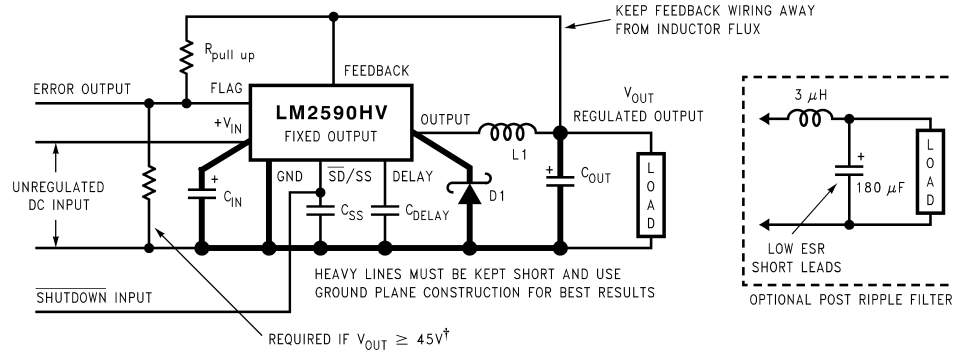


10134723

Order Number **LM2590HVS-3.3, LM2590HVS-5.0,**  
 or **LM2590HVS-ADJ**  
 See NS Package Number **TS7B**

# Test Circuit and Layout Guidelines

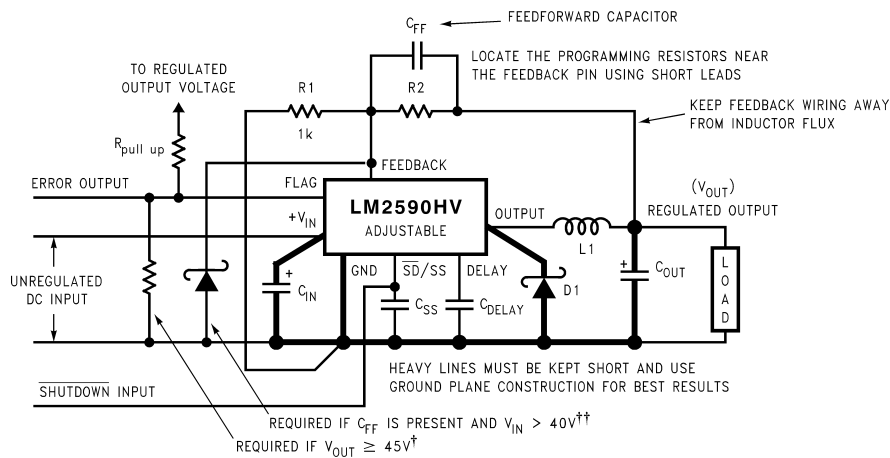
## Fixed Output Voltage Versions



- Component Values shown are for  $V_{IN} = 15V$ ,  
 $V_{OUT} = 5V$ ,  $I_{LOAD} = 1A$ .  
 $C_{IN}$  — 470  $\mu F$ , 50V, Aluminum Electrolytic Nichicon "PM Series"  
 $C_{OUT}$  — 220  $\mu F$ , 25V Aluminum Electrolytic, Nichicon "PM Series"  
 $D1$  — 2A, 60V Schottky Rectifier, 21DQ06 (International Rectifier)  
 $L1$  — 68  $\mu H$ , See Inductor Selection Procedure

10134724

## Adjustable Output Voltage Versions



- Select  $R_1$  to be approximately 1 k $\Omega$ , use a 1% resistor for best stability.  
 Component Values shown are for  $V_{IN} = 20V$ ,  
 $V_{OUT} = 10V$ ,  $I_{LOAD} = 1A$ .  
 $C_{IN}$ : — 470  $\mu F$ , 35V, Aluminum Electrolytic Nichicon "PM Series"  
 $C_{OUT}$ : — 220  $\mu F$ , 35V Aluminum Electrolytic, Nichicon "PM Series"  
 $D1$  — 2A, 60V Schottky Rectifier, 21DQ06 (International Rectifier)  
 $L1$  — 100  $\mu H$ , See Inductor Selection Procedure

10134725

- $R_1$  — 1 k $\Omega$ , 1%  
 $R_2$  — 7.15k, 1%  
 $C_{FF}$  — 3.3 nF

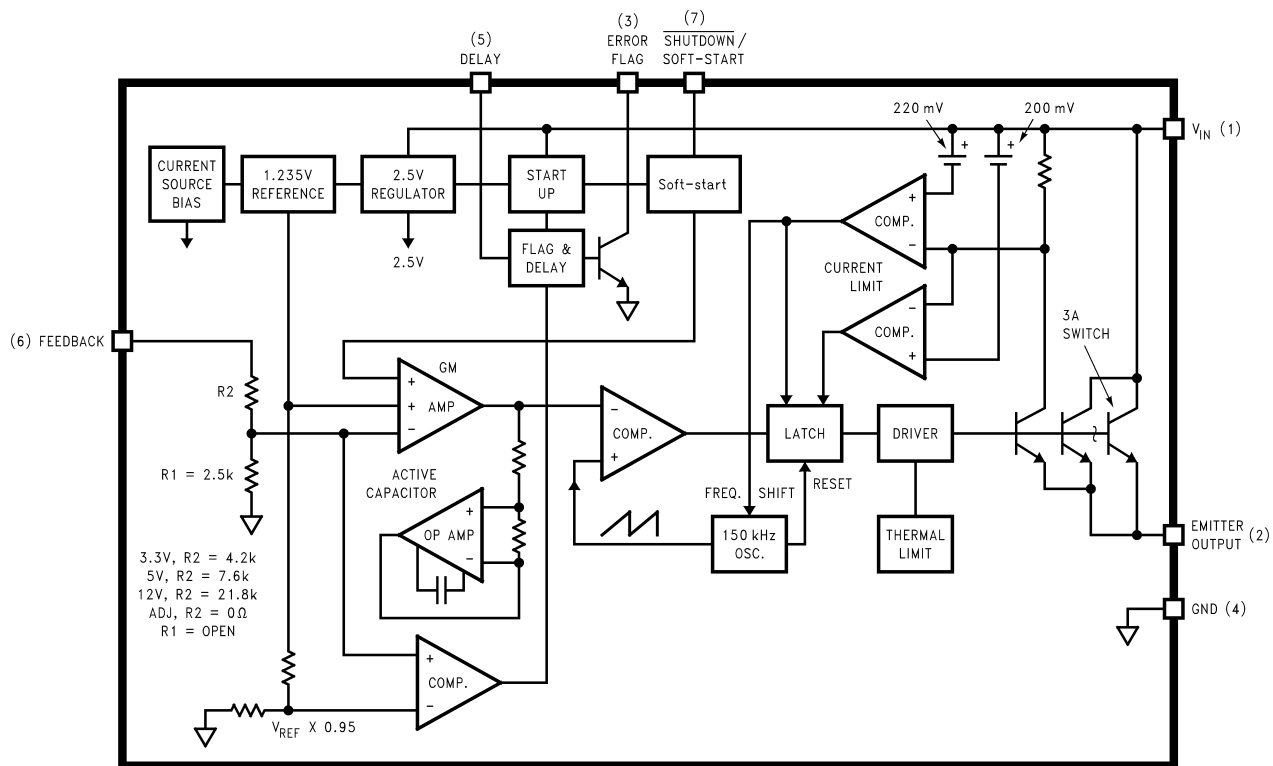
- Typical Values*  
 $C_{SS}$  — 0.1  $\mu F$   
 $C_{DELAY}$  — 0.1  $\mu F$   
 $R_{PULL UP}$  — 4.7k (use 22k if  $V_{OUT}$  is  $\geq 45V$ )

† Resistive divider is required to avoid exceeding maximum rating of 45V/3mA on/into flag pin.  
 †† Small signal Schottky diode to prevent damage to feedback pin by negative spike when output is shorted ( $C_{FF}$  not being able to discharge immediately will drag feedback pin below ground). Required if  $V_{IN} > 40V$

FIGURE 1. Standard Test Circuits and Layout Guides



## Block Diagram



10134730

## PIN FUNCTIONS

**+V<sub>IN</sub>** (Pin 1)—This is the positive input supply for the IC switching regulator. A suitable input bypass capacitor must be present at this pin to minimize voltage transients and to supply the switching currents needed by the regulator.

**Output** (Pin 2)—Internal switch. The voltage at this pin switches between approximately  $(+V_{IN} - V_{SAT})$  and approximately  $-0.5V$ , with a duty cycle of  $V_{OUT}/V_{IN}$ .

**Error Flag** (Pin 3)—Open collector output that goes active low ( $\leq 1.0V$ ) when the output of the switching regulator is out of regulation (less than 95% of its nominal value). In this state it can sink maximum 3mA. When not low, it can be pulled high to signal that the output of the regulator is in regulation (power good). During power-up, it can be programmed to go high after a certain delay as set by the Delay pin (Pin 5). The maximum rating of this pin should not be exceeded, so if the rail to which it will be pulled-up to is higher than 45V, a resistive divider must be used instead of a single pull-up resistor, as indicated in *Figure 1*.

**Ground** (Pin 4)—Circuit ground.

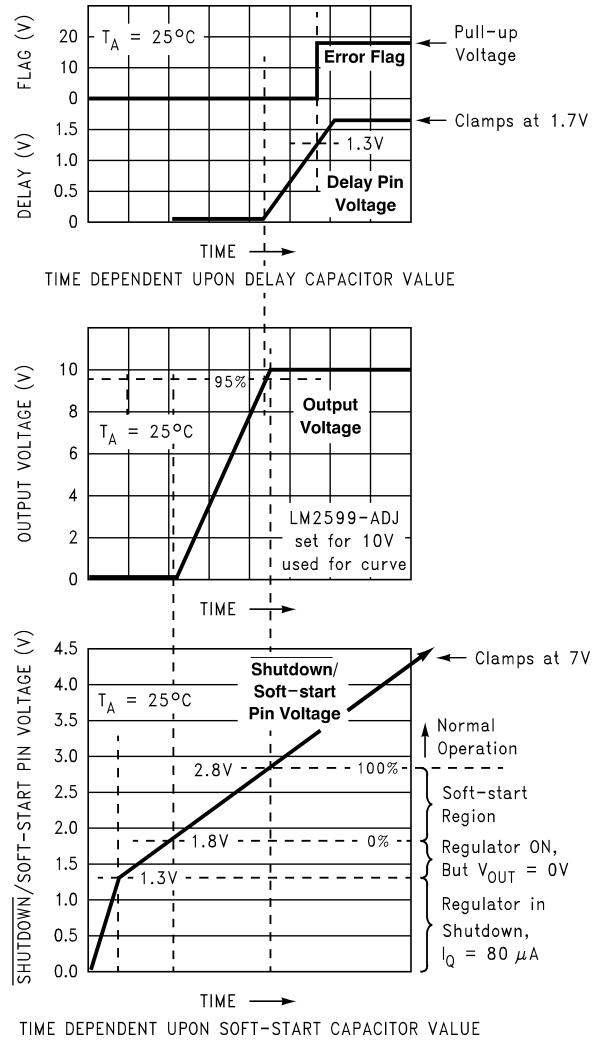
**Delay** (Pin 5)—This sets a programmable power-up delay from the moment that the output reaches regulation, to the high signal output (power good) on Pin 3. A capacitor on this pin starts charging up by means on an internal ( $\approx 3 \mu A$ ) current source when the regulated output rises to within 5% of its nominal value. Pin 3 goes high (with an external pull-up) when the voltage on the capacitor on Pin 5 exceeds 1.3V. The voltage on this pin is clamped internally to about 1.7V. If the regulated output drops out of regulation (less than 95% of its nominal value), the capacitor on Pin 5 is rapidly discharged internally and Pin 3 will be forced low in about  $1/1000^{\text{th}}$  of the set power-up delay time.

**Feedback** (Pin 6)—Senses the regulated output voltage to complete the feedback loop. This pin is directly connected to the Output for the fixed voltage versions, but is set to 1.23V by means of a resistive divider from the output for the Adjustable version. If a feedforward capacitor is used (Adjustable version), then a negative voltage spike is generated on this pin whenever the output is shorted. This happens because the feedforward capacitor cannot discharge fast enough, and since one end of it is dragged to Ground, the other end goes momentarily negative. To prevent the energy rating of this pin from being exceeded, a small-signal Schottky diode to Ground is recommended for DC input voltages above 40V whenever a feedforward capacitor is present (See *Figure 1*). Feedforward capacitor values larger than  $0.1 \mu F$  are not recommended for the same reason, whatever be the DC input voltage.

**Shutdown /Soft-start** (Pin 7)—The regulator is in shutdown mode, drawing about  $90 \mu A$ , when this pin is driven to a low level ( $\leq 0.6V$ ), and is in normal operation when this Pin is left floating (internal-pullup) or driven to a high level ( $\geq 2.0V$ ). The typical value of the threshold is 1.3V and the pin is internally clamped to a maximum of about 7V. If it is driven higher than the clamp voltage, it must be ensured by means of an external resistor that the current into the pin does not exceed 1mA. The duty cycle is minimum (0%) if this Pin is below 1.8V, and increases as the voltage on the pin is increased. The maximum duty cycle (100%) occurs when this pin is at 2.8V or higher. So adding a capacitor to this pin produces a softstart feature. An internal current source will charge the capacitor from zero to its internally clamped value. The charging current is about  $5 \mu A$  when the pin is below 1.3V but is reduced to only  $1.6 \mu A$  above 1.3V, so as to allow the use of smaller softstart capacitors.

## PIN FUNCTIONS (Continued)

**Note** If any of the above three features (Shutdown/Soft-start, Error Flag, or Delay) are not used, the respective pins can be left open.



10134731

**FIGURE 2. Soft-Start, Delay, Error Output**

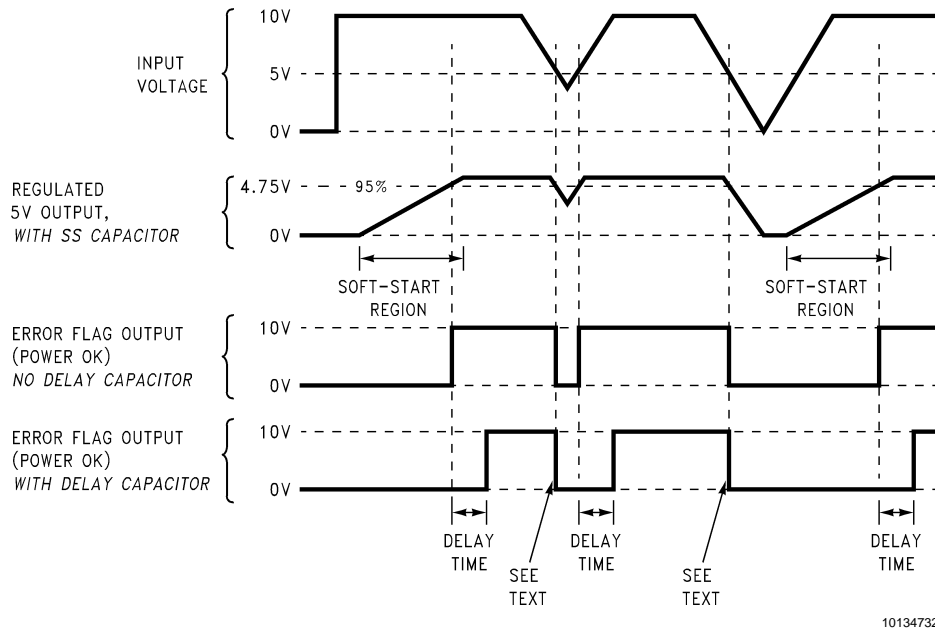


FIGURE 3. Timing Diagram for 5V Output

## INDUCTOR VALUE SELECTION GUIDES

(For Continuous Mode Operation)

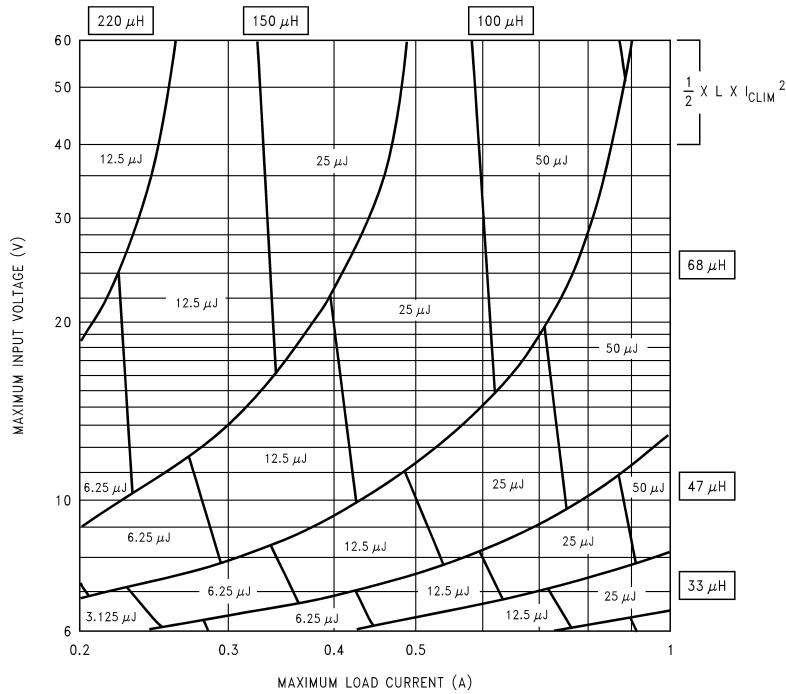
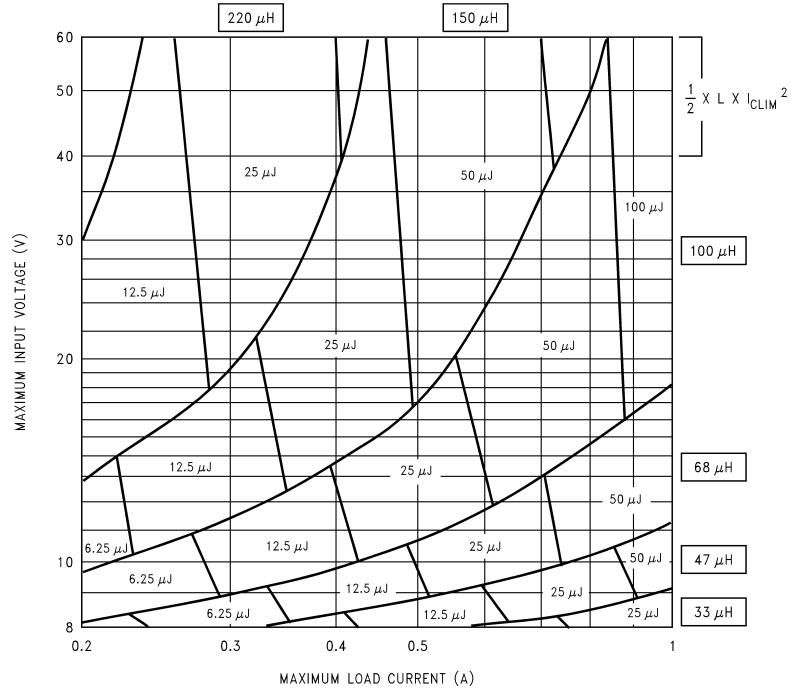


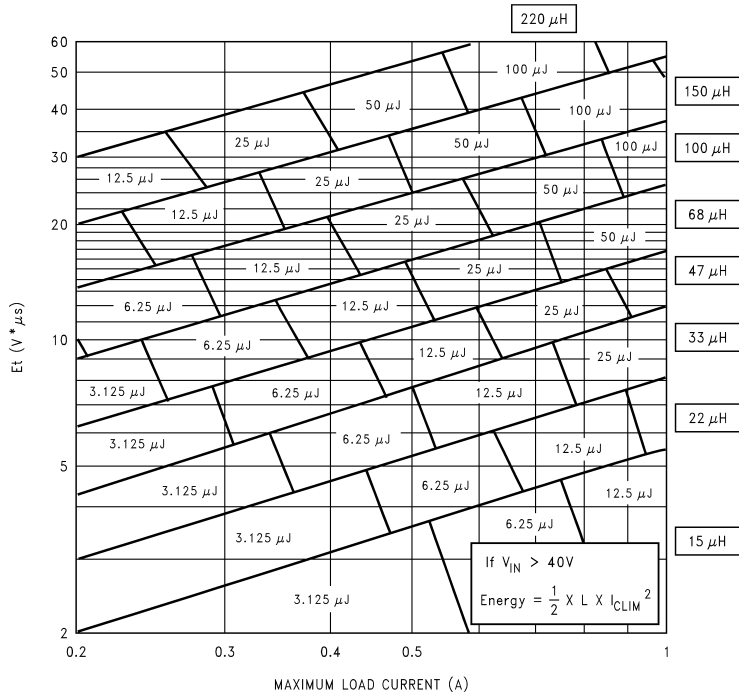
FIGURE 4. LM2590HV-3.3

# INDUCTOR VALUE SELECTION GUIDES (For Continuous Mode Operation) (Continued)



10134727

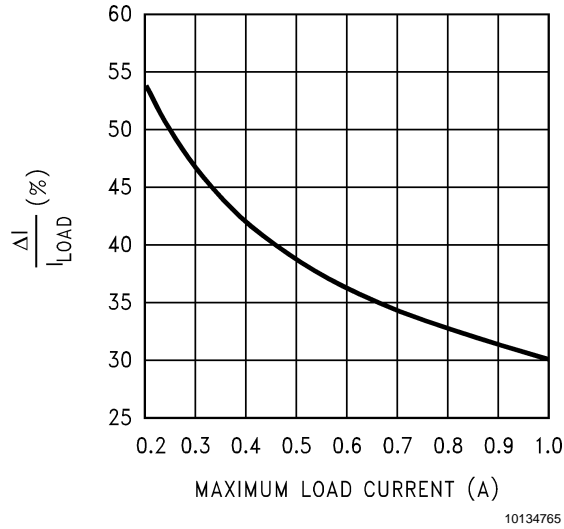
FIGURE 5. LM2590HV-5.0



10134729

FIGURE 6. LM2590HV-ADJ

**INDUCTOR VALUE SELECTION GUIDES** (For Continuous Mode Operation) (Continued)



**FIGURE 7. Current Ripple Ratio**

<b>Coilcraft Inc.</b>	Phone	(USA): 1-800-322-2645
	Web Address	<a href="http://www.coilcraft.com">http://www.coilcraft.com</a>
<b>Coilcraft Inc., Europe</b>	Phone	(UK): 1-236-730595
	Web Address	<a href="http://www.coilcraft-europe.com">http://www.coilcraft-europe.com</a>
<b>Pulse Engineering Inc.</b>	Phone	(USA): 1-858-674-8100
	Web Address	<a href="http://www.pulseeng.com">http://www.pulseeng.com</a>
<b>Pulse Engineering Inc., Europe</b>	Phone	(UK): 1-483-401700
	Web Address	<a href="http://www.pulseeng.com">http://www.pulseeng.com</a>
<b>Renco Electronics Inc.</b>	Phone	(USA): 1-321-637-1000
	Web Address	<a href="http://www.rencousa.com">http://www.rencousa.com</a>
<b>Schott Corp.</b>	Phone	(USA): 1-952-475-1173
	Web Address	<a href="http://www.shottcorp.com">http://www.shottcorp.com</a>
<b>Cooper Electronic Tech. (Coiltronics)</b>	Phone	(USA): 1-888-414-2645
	Web Address	<a href="http://www.cooperet.com">http://www.cooperet.com</a>

**FIGURE 8. Contact Information for Suggested Inductor Manufacturers**

## Application Information

### INDUCTOR SELECTION PROCEDURE

Application Note AN-1197 titled 'Selecting Inductors for Buck Converters' provides detailed information on this topic. For a quick-start the designer may refer to the nomographs provided in *Figure 4* to *Figure 6*. To widen the choice of the Designer to a more general selection of available inductors, the nomographs provide the required inductance and also the energy in the core expressed in microjoules ( $\mu\text{J}$ ), as an alternative to just prescribing custom parts. The following points need to be highlighted:

1. The Energy values shown on the nomographs apply to steady operation at the corresponding x-coordinate (rated maximum load current). However under start-up, without soft-start, or a short-circuit on the output, the current in the inductor will momentarily/repetitively hit the current limit  $I_{\text{CLIM}}$  of the device, and this current could be much higher than the rated load,  $I_{\text{LOAD}}$ . This represents an overload situation, and can cause the Inductor to saturate (if it has been designed only to handle the energy of steady operation). However most types of core structures used for such applications have a large inherent air gap (for example powdered iron types or ferrite rod inductors), and so the inductance does not fall off too sharply under an overload. The device is usually able to protect itself by not allowing the current to ever exceed  $I_{\text{CLIM}}$ . But if the DC input voltage to the regulator is over 40V, the current can slew up so fast under core saturation, that the device may not be able to act fast enough to restrict the current. The current can then rise without limit till destruction of the device takes place. *Therefore to ensure reliability, it is recommended, that if the DC Input Voltage exceeds 40V, the inductor must ALWAYS be sized to handle an instantaneous current equal to  $I_{\text{CLIM}}$  without saturating, irrespective of the type of core structure/material.*
2. The Energy under steady operation is

$$e = \frac{1}{2} \times L \times I_{\text{PEAK}}^2 \mu\text{J}$$

where  $L$  is in  $\mu\text{H}$  and  $I_{\text{PEAK}}$  is the peak of the inductor current waveform with the regulator delivering  $I_{\text{LOAD}}$ . These are the energy values shown in the nomographs. See *Example 1* below.

3. The Energy under overload is

$$e_{\text{CLIM}} = \frac{1}{2} \times L \times I_{\text{CLIM}}^2 \mu\text{J}$$

If  $V_{\text{IN}} > 40\text{V}$ , the inductor should be sized to handle  $e_{\text{CLIM}}$  instead of the steady energy values. The worst case  $I_{\text{CLIM}}$  for the LM2590HV is 3A. The Energy rating depends on the Inductance. See *Example 2* below.

4. The nomographs were generated by allowing a greater amount of percentage current ripple in the Inductor as the maximum rated load decreases (see *Figure 7*). This was done to permit the use of smaller inductors at light loads. *Figure 7* however shows only the 'median' value of the current ripple. In reality there may be a great spread around this because the nomographs approximate the exact calculated inductance to standard available values. It is a good idea to refer to AN-1197 for detailed calculations if a certain maximum inductor current ripple is required for various possible reasons. Also

consider the rather wide tolerance on the nominal inductance of commercial inductors.

5. *Figure 6* shows the inductor selection curves for the Adjustable version. The y-axis is 'Et', in  $\text{V}\mu\text{secs}$ . It is the applied volts across the inductor during the ON time of the switch ( $V_{\text{IN}} - V_{\text{SAT}} - V_{\text{OUT}}$ ) multiplied by the time for which the switch is on in  $\mu\text{secs}$ . See *Example 3* below.

**Example 1:** ( $V_{\text{IN}} \leq 40\text{V}$ ) LM2590HV-5.0,  $V_{\text{IN}} = 24\text{V}$ , Output 5V @ 0.8A

1. A first pass inductor selection is based upon *Inductance and rated max load current*. We choose an inductor with the Inductance value indicated by the nomograph (*Figure 5*) and a current rating equal to the maximum load current. We therefore quick-select a 100 $\mu\text{H}$ /0.8 A inductor (designed for 150 kHz operation) for this application.
2. We should confirm that it is rated to handle 50  $\mu\text{J}$  (see *Figure 5*) by either estimating the peak current or by a detailed calculation as shown in AN-1197, and also that the losses are acceptable.

**Example 2:** ( $V_{\text{IN}} > 40\text{V}$ ) LM2590HV-5.0,  $V_{\text{IN}} = 48\text{V}$ , Output 5V @ 1A

1. A first pass inductor selection is based upon *Inductance and the switch current limit*. We choose an inductor with the Inductance value indicated by the nomograph (*Figure 5*) and a current rating equal to  $I_{\text{CLIM}}$ . We therefore quick-select a 100 $\mu\text{H}$ /3A inductor (designed for 150 kHz operation) for this application.
2. We should confirm that it is rated to handle  $e_{\text{CLIM}}$  by the procedure shown in AN-1197 and that the losses are acceptable. Here  $e_{\text{CLIM}}$  is:

$$e_{\text{CLIM}} = \frac{1}{2} \times 100 \times 3^2 = 450 \mu\text{J}$$

**Example 3:** ( $V_{\text{IN}} \leq 40\text{V}$ ) LM2590HV-ADJ,  $V_{\text{IN}} = 20\text{V}$ , Output 10V @ 1A

1. Since input voltage is less than 40V, a first pass inductor selection is based upon *Inductance and rated max load current*. We choose an inductor with the Inductance value indicated by the nomograph *Figure 6* and a current rating equal to the maximum load. But we first need to calculate Et for the given application. The Duty cycle is

$$D = \frac{V_{\text{OUT}} + V_{\text{D}}}{V_{\text{IN}} - V_{\text{SAT}} + V_{\text{D}}}$$

where  $V_{\text{D}}$  is the drop across the Catch Diode ( $\approx 0.5\text{V}$  for a Schottky) and  $V_{\text{SAT}}$  the drop across the switch ( $\approx 1.5\text{V}$ ). So

$$D = \frac{10 + 0.5}{20 - 1.5 + 0.5} = 0.55$$

And the switch ON time is

$$t_{\text{ON}} = \frac{D}{f} \times 10^6 \mu\text{s}$$

where  $f$  is the switching frequency in Hz. So

## Application Information (Continued)

$$\begin{aligned} E_t &= (V_{IN} - V_{SAT} - V_{OUT}) \times t_{ON} \\ &= (20 - 1.5 - 10) \times \frac{0.55}{150000} \times 10^6 \text{ V}\mu\text{secs} \\ &= 31.3 \text{ V}\mu\text{secs} \end{aligned}$$

Therefore, looking at *Figure 4* we quick-select a 100μH/1A inductor (designed for 150 kHz operation) for this application.

2. We should confirm that it is rated to handle 100 μJ (see *Figure 6*) by the procedure shown in AN-1197 and that the losses are acceptable. (If the DC Input voltage had been greater than 40V we would need to consider  $e_{CLIM}$  as in Example 2 above).

Note that we have taken  $V_{SAT}$  as 1.5V which includes an estimated resistive drop across the inductor.

This completes the simplified inductor selection procedure. For more general applications and better optimization, the designer should refer to AN-1197. *Figure 8* provides helpful contact information on suggested Inductor manufacturers who may be able to recommend suitable parts, if the requirements are known.

### FEEDFORWARD CAPACITOR

(Adjustable Output Voltage Version)

$C_{FF}$  - A Feedforward Capacitor  $C_{FF}$ , shown across R2 in *Figure 1* is used when the output voltage is greater than 10V or when  $C_{OUT}$  has a very low ESR. This capacitor adds lead compensation to the feedback loop and increases the phase margin for better loop stability.

If the output voltage ripple is large (> 5% of the nominal output voltage), this ripple can be coupled to the feedback pin through the feedforward capacitor and cause the error comparator to trigger the error flag. In this situation, adding a resistor,  $R_{FF}$ , in series with the feedforward capacitor, approximately 3 times R1, will attenuate the ripple voltage at the feedback pin.

### INPUT CAPACITOR

$C_{IN}$  —A low ESR aluminum or tantalum bypass capacitor is needed between the input pin and ground pin. It must be located near the regulator using short leads. This capacitor prevents large voltage transients from appearing at the input, and provides the instantaneous current needed each time the switch turns on.

The important parameters for the Input capacitor are the voltage rating and the RMS current rating. Because of the

relatively high RMS currents flowing in a buck regulator's input capacitor, this capacitor should be chosen for its RMS current rating rather than its capacitance or voltage ratings, although the capacitance value and voltage rating are directly related to the RMS current rating. The voltage rating of the capacitor and its RMS ripple current capability must never be exceeded.

### OUTPUT CAPACITOR

$C_{OUT}$  —An output capacitor is required to filter the output and provide regulator loop stability. Low impedance or low ESR Electrolytic or solid tantalum capacitors designed for switching regulator applications must be used. When selecting an output capacitor, the important capacitor parameters are; the 100 kHz Equivalent Series Resistance (ESR), the RMS ripple current rating, voltage rating, and capacitance value. For the output capacitor, the ESR value is the most important parameter. The ESR should generally not be less than 100 mΩ or there will be loop instability. If the ESR is too large, efficiency and output voltage ripple are effected. So ESR must be chosen carefully.

### CATCH DIODE

Buck regulators require a diode to provide a return path for the inductor current when the switch turns off. This must be a fast diode and must be located close to the LM2590HV using short leads and short printed circuit traces.

Because of their very fast switching speed and low forward voltage drop, Schottky diodes provide the best performance, especially in low output voltage applications (5V and lower). Ultra-fast recovery, or High-Efficiency rectifiers are also a good choice, but some types with an abrupt turnoff characteristic may cause instability or EMI problems. Ultra-fast recovery diodes typically have reverse recovery times of 50 ns or less. The diode must be chosen for its average/RMS current rating and maximum voltage rating. The voltage rating of the diode must be greater than the DC input voltage (not the output voltage).

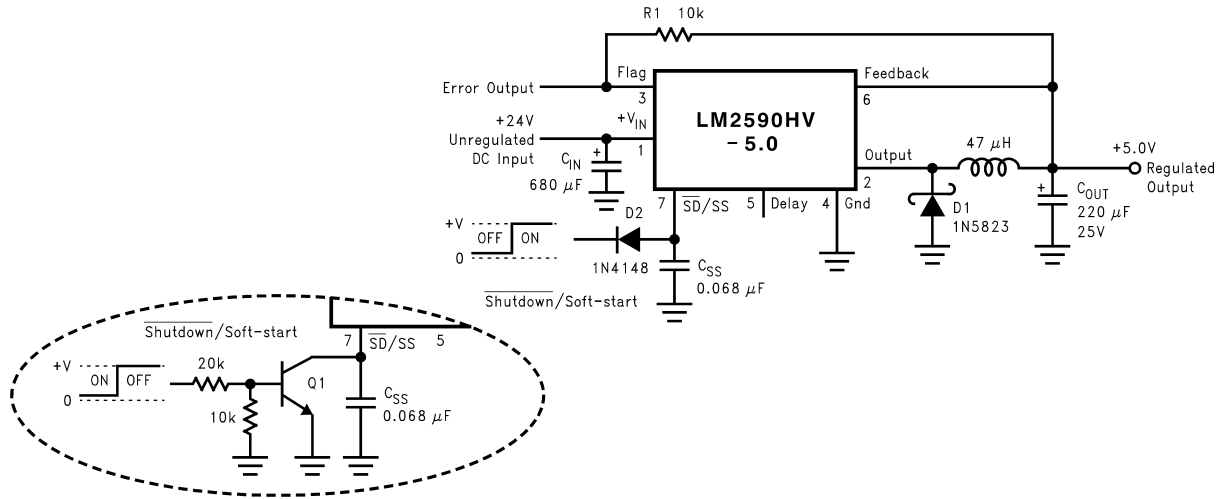
### SHUTDOWN /SOFT-START

This reduction in start up current is useful in situations where the input power source is limited in the amount of current it can deliver. In some applications Soft-start can be used to replace undervoltage lockout or delayed startup functions.

If a very slow output voltage ramp is desired, the Soft-start capacitor can be made much larger. Many seconds or even minutes are possible.

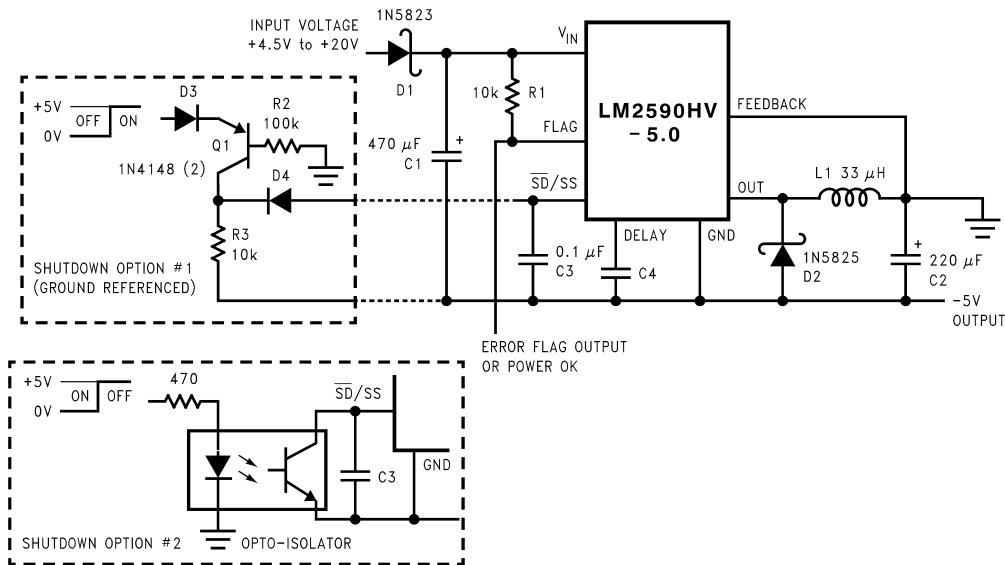
If only the shutdown feature is needed, the Soft-start capacitor can be eliminated.

Application Information (Continued)



10134742

FIGURE 9. Typical Circuit Using Shutdown /Soft-start and Error Flag Features



10134743

FIGURE 10. Inverting -5V Regulator With Shutdown and Soft-start

**INVERTING REGULATOR**

The circuit in Figure 10 converts a positive input voltage to a negative output voltage with a common ground. The circuit operates by bootstrapping the regulator's ground pin to the negative output voltage, then grounding the feedback pin, the regulator senses the inverted output voltage and regulates it.

This example uses the LM2590HV-5 to generate a -5V output, but other output voltages are possible by selecting other output voltage versions, including the adjustable version. Since this regulator topology can produce an output voltage that is either greater than or less than the input voltage, the maximum output current greatly depends on both the input and output voltage.

To determine how much load current is possible before the internal device current limit is reached (and power limiting

occurs), the system must be evaluated as a buck-boost configuration rather than as a buck. The peak switch current in Amperes, for such a configuration is given as:

$$I_{PEAK} = I_{LOAD} \times \left( \frac{V_{IN} + V_{OUT}}{V_{IN}} \right) + \frac{V_{IN} \times V_{OUT} \times 10^6}{2 \times L \times f \times (V_{IN} + V_{OUT})}$$

where L is in µH and f is in Hz. The maximum possible load current  $I_{LOAD}$  is limited by the requirement that  $I_{PEAK} \leq I_{CLIM}$ . While checking for this, take  $I_{CLIM}$  to be the lowest possible current limit value (min across tolerance and temperature is 1.2A for the LM2590HV). Also to account for inductor tolerances, we should take the min value of Inductance for L in the equation above (typically 20% less than the nominal value). Further, the above equation disregards the drop across the Switch and the diode. This is equivalent to as-



## Application Information (Continued)

suming 100% efficiency, which is never so. Therefore expect  $I_{PEAK}$  to be an additional 10-20% higher than calculated from the above equation.

The reader is also referred to Application Note AN-1157 for examples based on positive to negative configuration.

The maximum voltage appearing across the regulator is the absolute sum of the input and output voltage, and this must be limited to a maximum of 60V. In this example, when converting +20V to -5V, the regulator would see 25V between the input pin and ground pin. The LM2590HV has a maximum input voltage rating of 60V.

An additional diode is required in this regulator configuration. Diode D1 is used to isolate input voltage ripple or noise from coupling through the  $C_{IN}$  capacitor to the output, under light or no load conditions. Also, this diode isolation changes the topology to closely resemble a buck configuration thus providing good closed loop stability. A Schottky diode is recommended for low input voltages, (because of its lower voltage drop) but for higher input voltages, a 1N5400 diode could be used.

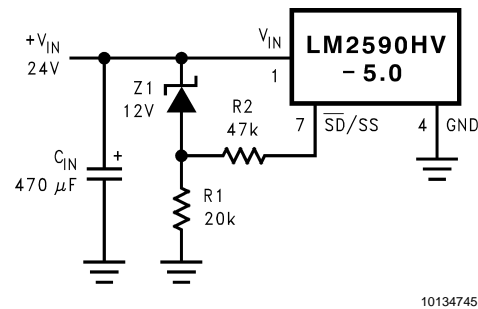
Because of differences in the operation of the inverting regulator, the standard design procedure is not used to select the inductor value. In the majority of designs, a 33  $\mu$ H, 3A inductor is the best choice. Capacitor selection can also be narrowed down to just a few values.

This type of inverting regulator can require relatively large amounts of input current when starting up, even with light loads. Input currents as high as the LM2590HV current limit (approximately 3.0A) are needed for 2 ms or more, until the output reaches its nominal output voltage. The actual time depends on the output voltage and the size of the output capacitor. Input power sources that are current limited or sources that can not deliver these currents without getting loaded down, may not work correctly. Because of the relatively high startup currents required by the inverting topology, the Soft-Start feature shown in *Figure 10* is recommended.

Also shown in *Figure 10* are several shutdown methods for the inverting configuration. With the inverting configuration, some level shifting is required, because the ground pin of the regulator is no longer at ground, but is now at the negative output voltage. The shutdown methods shown accept ground referenced shutdown signals.

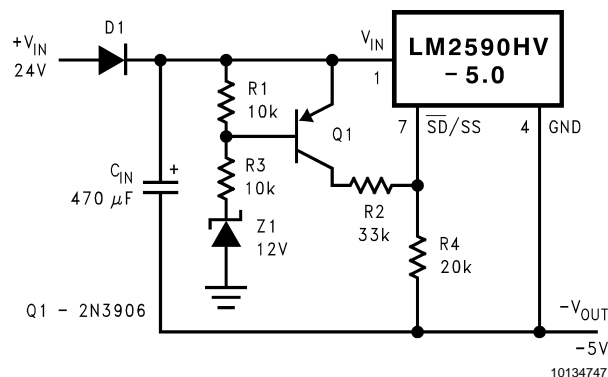
### UNDERVOLTAGE LOCKOUT

Some applications require the regulator to remain off until the input voltage reaches a predetermined voltage. *Figure 11* contains a undervoltage lockout circuit for a buck configuration, while *Figure 12* and *Figure 13* are for the inverting types (only the circuitry pertaining to the undervoltage lockout is shown). *Figure 11* uses a zener diode to establish the threshold voltage when the switcher begins operating. When the input voltage is less than the zener voltage, resistors R1 and R2 hold the Shutdown /Soft-start pin low, keeping the regulator in the shutdown mode. As the input voltage exceeds the zener voltage, the zener conducts, pulling the Shutdown /Soft-start pin high, allowing the regulator to begin switching. The threshold voltage for the undervoltage lockout feature is approximately 1.5V greater than the zener voltage.

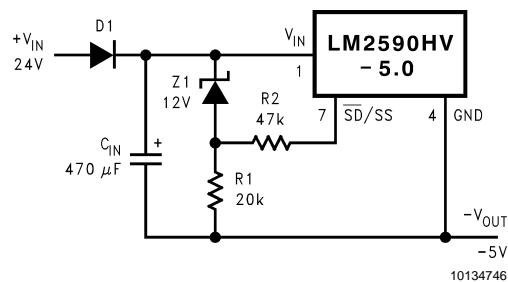


**FIGURE 11. Undervoltage Lockout for a Buck Regulator**

*Figure 12* and *Figure 13* apply the same feature to an inverting circuit. *Figure 12* features a constant threshold voltage for turn on and turn off (zener voltage plus approximately one volt). If hysteresis is needed, the circuit in *Figure 13* has a turn ON voltage which is different than the turn OFF voltage. The amount of hysteresis is approximately equal to the value of the output voltage. Since the  $\overline{SD}/SS$  pin has an internal 7V zener clamp, R2 is needed to limit the current into this pin to approximately 1 mA when Q1 is on.



**FIGURE 12. Undervoltage Lockout Without Hysteresis for an Inverting Regulator**



**FIGURE 13. Undervoltage Lockout With Hysteresis for an Inverting Regulator**

### Layout Suggestions

As in any switching regulator, layout is very important. Rapidly switching currents associated with wiring inductance can generate voltage transients which can cause problems. For minimal inductance and ground loops, with reference to *Figure 1*, the wires indicated by **heavy lines** should be wide printed circuit traces and should be kept as short as

## Application Information (Continued)

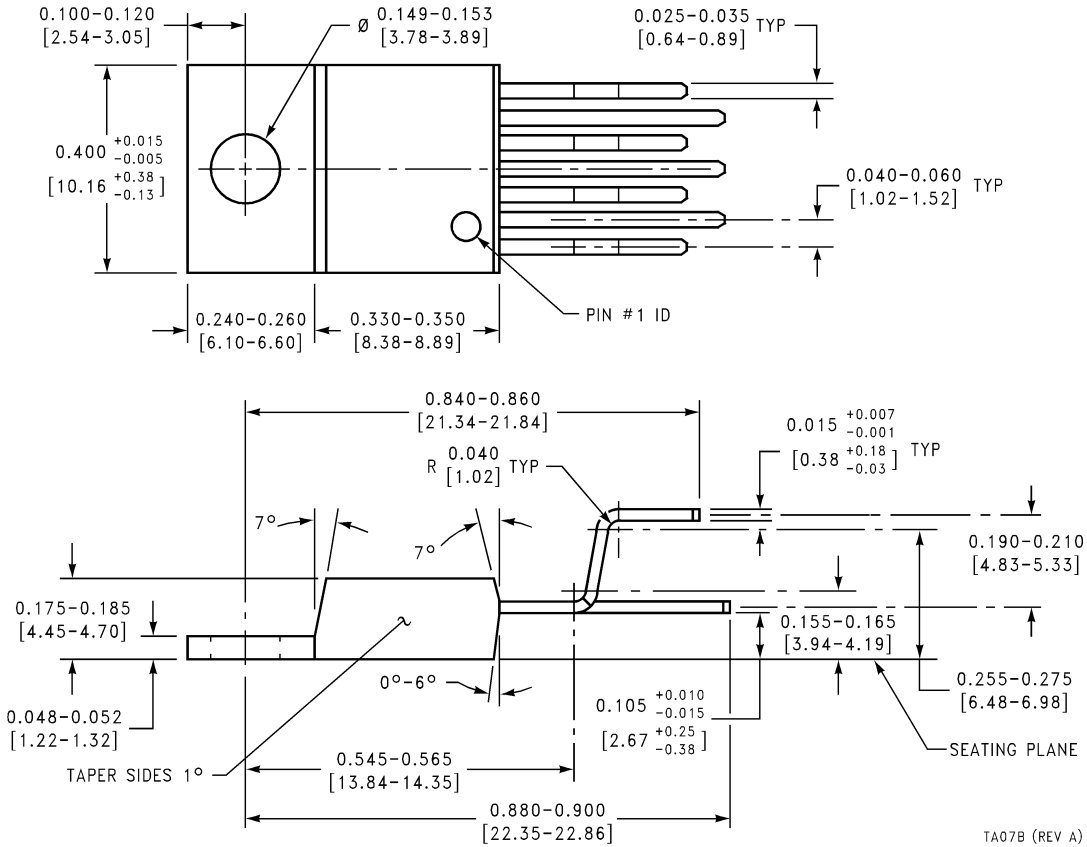
**possible.** For best results, external components should be located as close to the switcher IC as possible using ground plane construction or single point grounding.

If **open core inductors are used**, special care must be taken as to the location and positioning of this type of inductor. Allowing the inductor flux to intersect sensitive feedback, IC groundpath and  $C_{OUT}$  wiring can cause problems.

When using the adjustable version, special care must be taken as to the location of the feedback resistors and the associated wiring. Physically locate both resistors near the IC, and route the wiring away from the inductor, especially an open core type of inductor.

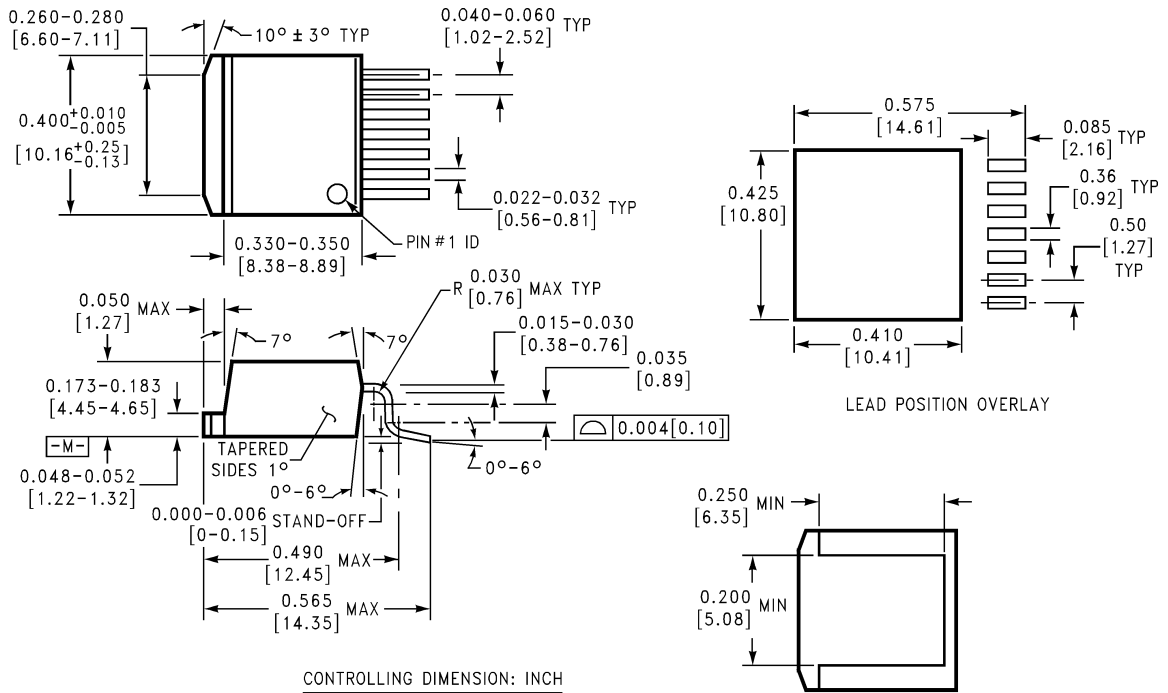
**Physical Dimensions** inches (millimeters)

unless otherwise noted



**7-Lead TO-220 Bent and Staggered Package**  
**Order Number LM2590HVT-3.3, LM2590HVT-5.0 or LM2590HVT-ADJ**  
**NS Package Number TA07B**

**Physical Dimensions** inches (millimeters) unless otherwise noted (Continued)



**7-Lead TO-263 Bent and Formed Package**  
**Order Number LM2590HVS-3.3, LM2590HVS-5.0 or LM2590HVS-ADJ**  
**NS Package Number TS7B**

BACK VIEW TS7B (REV B)

**LIFE SUPPORT POLICY**

NATIONAL'S PRODUCTS ARE NOT AUTHORIZED FOR USE AS CRITICAL COMPONENTS IN LIFE SUPPORT DEVICES OR SYSTEMS WITHOUT THE EXPRESS WRITTEN APPROVAL OF THE PRESIDENT AND GENERAL COUNSEL OF NATIONAL SEMICONDUCTOR CORPORATION. As used herein:

1. Life support devices or systems are devices or systems which, (a) are intended for surgical implant into the body, or (b) support or sustain life, and whose failure to perform when properly used in accordance with instructions for use provided in the labeling, can be reasonably expected to result in a significant injury to the user.
2. A critical component is any component of a life support device or system whose failure to perform can be reasonably expected to cause the failure of the life support device or system, or to affect its safety or effectiveness.

**National Semiconductor Corporation**  
 Americas  
 Email: support@nsc.com

www.national.com

**National Semiconductor Europe**  
 Fax: +49 (0) 180-530 85 86  
 Email: europe.support@nsc.com  
 Deutsch Tel: +49 (0) 69 9508 6208  
 English Tel: +44 (0) 870 24 0 2171  
 Français Tel: +33 (0) 1 41 91 8790

**National Semiconductor Asia Pacific Customer Response Group**  
 Tel: 65-2544466  
 Fax: 65-2504466  
 Email: ap.support@nsc.com

**National Semiconductor Japan Ltd.**  
 Tel: 81-3-5639-7560  
 Fax: 81-3-5639-7507