



---

STMTouch™ – STM8T141 proximity and touchkey controller  
frequently asked and anticipated questions (FAQs)

---

## **1 Introduction**

This document contains a list of frequently asked and anticipated questions (FAQs) concerning the STM8T141.

The STM8T141 is a single-channel 8-pin capacitive controller for human touch or nearby proximity detection (up to a few centimeters). This solution replaces the “on/off” switch and mechanical buttons of most human interfaces. It also enhances the user experience by offering new activation and gesture controls.

The STM8T141 offers power consumption below 12  $\mu$ A and simultaneously reports the detection with a fast response time which is ideal for power critical and battery supplied applications.

It brings new horizons and new application domains for designing the next generation of "hand held" devices, including mobile phones, multimedia players, gaming consoles, and Bluetooth headsets or headphones.

The STM8T141 has a single user configurable output to report the touch or proximity detection to the host processor.

# Table of contents

<b>1</b>	<b>Introduction</b> .....	<b>1</b>
<b>2</b>	<b>FAQs and answers</b> .....	<b>3</b>
2.1	How does human detection work? .....	3
2.2	What are the targeted applications? .....	3
2.3	What are the main features and benefits of the STM8T141 solution? ....	4
2.4	What is the driven shield feature designed for? .....	4
2.5	Is a specific calibration required in the production of the application or during its lifetime? .....	4
2.6	What is the bill of material? .....	5
2.7	What is the proximity range? .....	5
2.8	What development tools are associated with this product? .....	6
2.9	What documentation is associated with this product? .....	7
<b>3</b>	<b>Revision history</b> .....	<b>8</b>

## 2 FAQs and answers

### 2.1 How does human detection work?

The human detection is made using a well-known and proven technology called “capacitive charge transfer”. It is based on the fact that the human body acts as a conductive object. Basically, small changes in the capacitance of an electrode, which is affected by human presence, are measured. The electrode is usually made of a copper plate behind a dielectric.

To measure changes in the electrode capacitance, the STM8T141 device employs bursts of charge transfer cycles. Consequently, charges accumulated into the electrode capacitance are transferred to a sampling capacitor. This operation is repeated N times until the voltage on the sampling capacitor reaches a given threshold. The number, N, of transfer cycles required to reach the threshold represents the size of the electrode capacitance. N varies when the electrode is touched.

### 2.2 What are the targeted applications?

The STM8T141 opens up a range of new opportunities and a wide number of application domains still need to be explored.

The power supply (2 V to 5.5 V) of the product and its extremely compact package size (either UDFPN8 2 x 3 mm or SO8 narrow) benefits battery powered systems for integration in miniature environments.

The device is suitable for the following functions:

- On/off switch or activation button.
- Wake-up function on user touch for power critical equipment and long battery lifetime.
- Backlight control on proximity detection.

Below, are listed several application examples:

- Elimination of mechanical buttons or on/off switches in high volume applications such as DVD/CD drives, computers, and coffee machines to enhance system reliability.
- Home button in GPS systems for easy and safe navigation in the application menu.
- Light activation switches on user touch and backlight on user proximity of wall switch outlets.
- A simple button to control power, audio line or volume adjustment in Bluetooth headsets.
- User ear or head detection in MP3 headphones to automatically play/stop music. The electrode is placed in the earpiece for nearby detection.
- Cost-effective solutions to replace Infrared proximity sensors in mobile phones for ear-face detection.
- User approach detection to wake-up wireless mice or keyboards.
- LCD TV front panel backlight control on hand detection.

## 2.3 What are the main features and benefits of the STM8T141 solution?

- Single channel capacitive sensor for touch or proximity detection with four user configurable sensitivity levels to accommodate different dielectric panel thicknesses and materials.
- One configurable output to report touch or proximity detection (active, toggle and latch modes).
- Compact 8-pin package: UDFPN8 (3 x 2 mm) or SO8 narrow
- On-chip voltage regulator to enhance the detection sensitivity and stability while offering high-level immunity against noise.
- Four selectable power modes including 11µA in extreme low power mode and 30 µA in normal mode.
- 2.0 V to 5.5 V voltage range suitable for most battery powered applications.
- Environment compensation filter and automatic calibration. There is no need for production line calibration or user calibration.
- Built-in driven shield function to enhance proximity detection and protect sensing electrode from noise.
- Detection timeout resets the output state after a configurable period of activation (15 s, 45 s, or infinite). This allows the device to recover from false detection due to drastic changes in the surroundings.

## 2.4 What is the driven shield feature designed for?

When powered with 4.5 V or more, the STM8T141 offers a built-in shielding function. It allows the sensing electrode to be placed at a distance from electronics or protects the electrode from unwanted environmental interference. The shield principle consists of actively driving the shield plane or element with the same signal waveform as the electrode one. It significantly reduces the impact of the capacitance electrode/shield on the sensed result.

## 2.5 Is a specific calibration required in the production of the application or during its lifetime?

The device calibrates when powered up thus it compensates for any process variations during the production cycle (for example, panel thickness variation between different production lots).

Over time, the device also adapts automatically its own internal reference values to compensate for any changes in power supply, temperature, and moisture.

## 2.6 What is the bill of material?

As shown in *Figure 1*, external component count is low. One sampling capacitor connected to the  $C_S$  pin is required for the charge transfer acquisition. Three additional filtering capacitors are necessary to connect to the power supply.

To compensate for the exposure of the electrode pad to electro-static discharges (ESD), an  $R_X$  resistor can be added. A typical value of 2 k $\Omega$  is usually used.

**Figure 1. External components of the STM8T141 device**

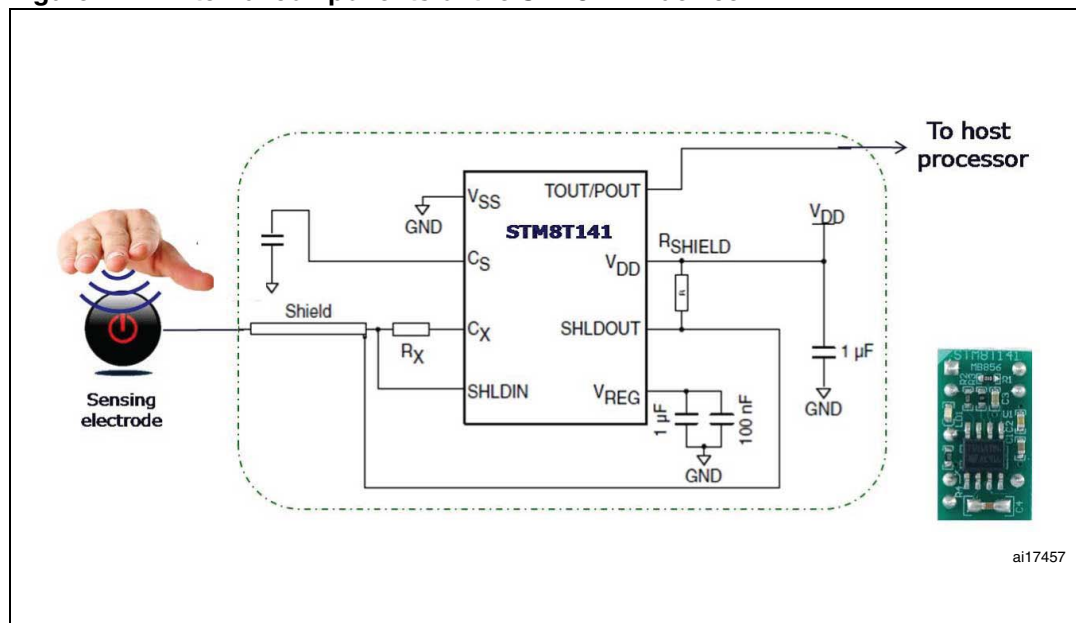

## 2.7 What is the proximity range?

The STM8T141 is capable of short range proximity detection. This range varies from a few centimeters up to 10/15 cms but, it is the result of many factors.

A dedicated application note (AN3150) is available to help designers understand which factors influence detection sensitivity. Examples include electrode shape and size, system ground, panel construction, surrounding metallic objects, and power supply.

## 2.8 What development tools are associated with this product?

The STM8T141-EVAL evaluation kit (*Figure 2*) is a low cost tool designed to quickly learn the STM8T141 device. The board is delivered with an on-board electrode and four plug-in modules which are programmed in two different configurations (touch and proximity) to evaluate device performance.

The board is battery operated but can be powered using a USB cable. It allows the proximity range in different system ground configurations to be evaluated.

An external cable antenna is supplied which replaces the on-board electrode when testing the shield feature.

Blank plugin modules are available in boxes of 10 pieces (STM8T141-MOD). They can be used independently or with the evaluation kit: they only require a power supply and an electrode to operate them.

A programming kit made of a socket board (STM8T14x-SB) and a USB dongle (ST-TSLINK) allows user options (including device sensitivity, output mode, shield, and detection timeout duration) to be changed. The socket board is able to program SO8 and UDFPN8 packages as well as the DIP14 modules.

**Figure 2. STM8T141-EVAL evaluation kit**

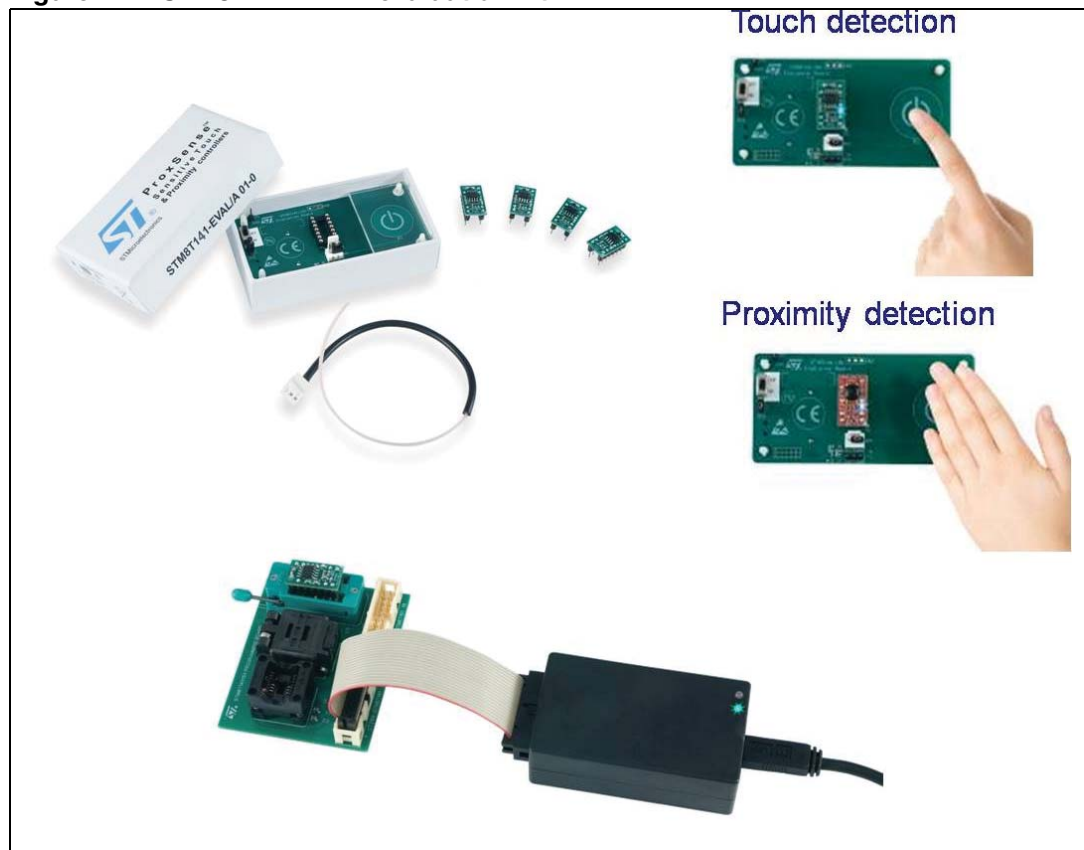

## 2.9 What documentation is associated with this product?

- AN2869: Guidelines for designing touch sensing applications
- AN2966: Capacitor selection guide for STM8T and STM8TS capacitive sensors
- AN3150: Proximity sensor guidelines using STM8T14x capacitive sensors
- UM0742: STM8T14x-EVAL evaluation kit

### 3 Revision history

Table 1. Document revision history

Date	Revision	Changes
02-Apr-2010	1	Initial release

**Please Read Carefully:**

Information in this document is provided solely in connection with ST products. STMicroelectronics NV and its subsidiaries ("ST") reserve the right to make changes, corrections, modifications or improvements, to this document, and the products and services described herein at any time, without notice.

All ST products are sold pursuant to ST's terms and conditions of sale.

Purchasers are solely responsible for the choice, selection and use of the ST products and services described herein, and ST assumes no liability whatsoever relating to the choice, selection or use of the ST products and services described herein.

No license, express or implied, by estoppel or otherwise, to any intellectual property rights is granted under this document. If any part of this document refers to any third party products or services it shall not be deemed a license grant by ST for the use of such third party products or services, or any intellectual property contained therein or considered as a warranty covering the use in any manner whatsoever of such third party products or services or any intellectual property contained therein.

**UNLESS OTHERWISE SET FORTH IN ST'S TERMS AND CONDITIONS OF SALE ST DISCLAIMS ANY EXPRESS OR IMPLIED WARRANTY WITH RESPECT TO THE USE AND/OR SALE OF ST PRODUCTS INCLUDING WITHOUT LIMITATION IMPLIED WARRANTIES OF MERCHANTABILITY, FITNESS FOR A PARTICULAR PURPOSE (AND THEIR EQUIVALENTS UNDER THE LAWS OF ANY JURISDICTION), OR INFRINGEMENT OF ANY PATENT, COPYRIGHT OR OTHER INTELLECTUAL PROPERTY RIGHT.**

**UNLESS EXPRESSLY APPROVED IN WRITING BY AN AUTHORIZED ST REPRESENTATIVE, ST PRODUCTS ARE NOT RECOMMENDED, AUTHORIZED OR WARRANTED FOR USE IN MILITARY, AIR CRAFT, SPACE, LIFE SAVING, OR LIFE SUSTAINING APPLICATIONS, NOR IN PRODUCTS OR SYSTEMS WHERE FAILURE OR MALFUNCTION MAY RESULT IN PERSONAL INJURY, DEATH, OR SEVERE PROPERTY OR ENVIRONMENTAL DAMAGE. ST PRODUCTS WHICH ARE NOT SPECIFIED AS "AUTOMOTIVE GRADE" MAY ONLY BE USED IN AUTOMOTIVE APPLICATIONS AT USER'S OWN RISK.**

Resale of ST products with provisions different from the statements and/or technical features set forth in this document shall immediately void any warranty granted by ST for the ST product or service described herein and shall not create or extend in any manner whatsoever, any liability of ST.

ST and the ST logo are trademarks or registered trademarks of ST in various countries.

Information in this document supersedes and replaces all information previously supplied.

The ST logo is a registered trademark of STMicroelectronics. All other names are the property of their respective owners.

© 2010 STMicroelectronics - All rights reserved

STMicroelectronics group of companies

Australia - Belgium - Brazil - Canada - China - Czech Republic - Finland - France - Germany - Hong Kong - India - Israel - Italy - Japan - Malaysia - Malta - Morocco - Philippines - Singapore - Spain - Sweden - Switzerland - United Kingdom - United States of America

[www.st.com](http://www.st.com)

