

HA16158P/FP

PFC & PWM Control IC

REJ03F0147-0200

Rev.2.00

Jan 30, 2007

Description

The HA16158 is a power supply controller IC combining an AC-DC converter switching controller for power factor correction and an off-line power supply switching controller. The PFC (power factor correction) section employs average current mode PWM and the off-line power supply control section employs peak current mode PWM.

The HA16158 allows the operating frequency to be varied with a single timing resistance, enabling it to be used for a variety of applications.

The PFC operation can be turned on and off by an external control signal. Use of this on/off function makes it possible to disable PFC operation at a low line voltage, or to perform remote control operation from the transformer secondary side.

The PWM controller includes a power-saving function that reduces the operating frequency to a maximum of 1/64 in the standby state, greatly decreasing switching loss.

The PFC section and PWM section are each provided with a soft start control pin, enabling a soft start time to be set easily.

Features

<Maximum Ratings>

- Supply voltage V_{cc} : 24 V
- Operating junction temperature T_{jopr} : -40°C to $+125^{\circ}\text{C}$

<Electrical Characteristics>

- VREF output voltage V_{REF} : $5.0\text{ V} \pm 2\%$
- UVLO start threshold V_H : $16.0\text{ V} \pm 1.0\text{ V}$
- UVLO shutdown threshold V_L : $10.0\text{ V} \pm 0.6\text{ V}$
- PFC output maximum duty cycle $D_{max-pfc}$: 95% typ.
- PWM output maximum duty cycle $D_{max-pwm}$: 45% typ.

<Functions>

- Synchronized PFC and PWM timing
- PFC function on/off control
- PWM power-saving function (frequency reduced to maximum of 1/64)
- PWM overvoltage latch protection circuit
- Soft start control circuits for both PFC and PWM
- Package lineup: SOP-16/DILP-16

Pin Arrangement

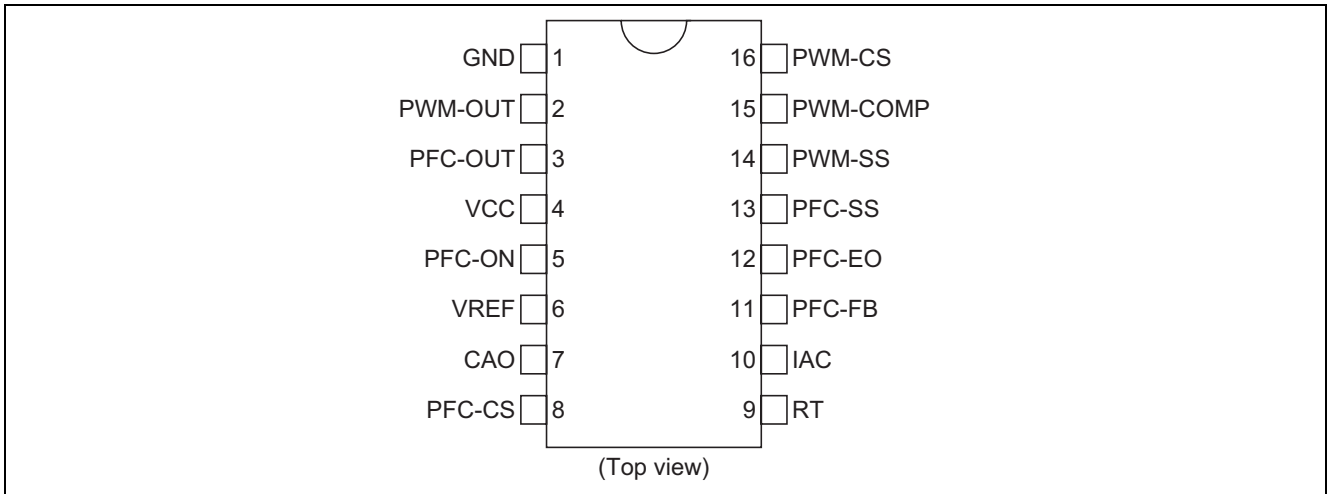

Pin Functions

Pin No.	Pin Name	Pin Functions
1	GND	Ground
2	PWM-OUT	Power MOS FET driver output (PWM control)
3	PFC-OUT	Power MOS FET driver output (PFC control)
4	VCC	Supply voltage
5	PFC-ON	PFC function on/off signal input
6	VREF	Reference voltage
7	CAO	Average current control error amplifier output
8	PFC-CS	PFC control current sense signal input
9	RT	Operating frequency setting timing resistance connection
10	IAC	Multiplier reference current input
11	PFC-FB	PFC control error amplifier input
12	PFC-EO	PFC control error amplifier output
13	PFC-SS	PFC control soft start time setting capacitance connection
14	PWM-SS	PWM control soft start time setting capacitance connection
15	PWM-COMP	PWM control voltage feedback
16	PWM-CS	PWM control current sense signal input

Block Diagram

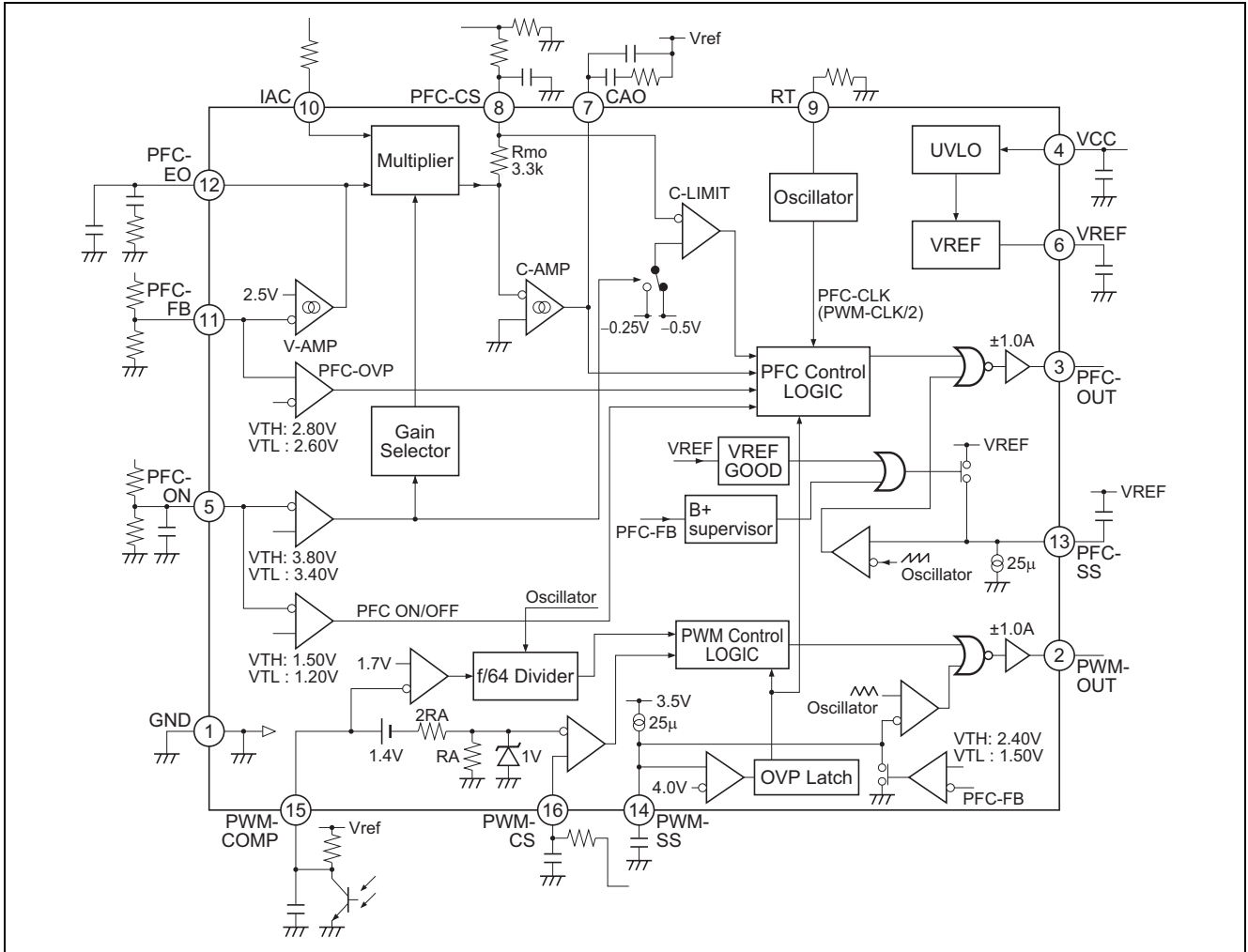

Absolute Maximum Ratings

(Ta = 25°C)

Item	Symbol	Ratings	Unit	Note
Power supply voltage	Vcc	24	V	
PFC-OUT output current (peak)	l _{pk-out1}	±1.0	A	3
PWM-OUT output current (peak)	l _{pk-out2}	±1.0	A	3
PFC-OUT output current (DC)	l _{dc-out1}	±0.1	A	
PWM-OUT output current (DC)	l _{dc-out2}	±0.1	A	
Pin voltage	V _{i-group1}	-0.3 to V _{cc}	V	4
	V _{i-group2}	-0.3 to V _{ref}	V	5
CAO pin voltage	V _{cao}	-0.3 to V _{eh-ca}	V	
PFC-EO pin voltage	V _{pfc-eo}	-0.3 to V _{eh-pfc}	V	
PFC-ON pin voltage	V _{pfc-on}	-0.3 to 7	V	
RT pin current	I _{rt}	50	μA	
IAC pin current	I _{iac}	1	mA	
PFC-CS pin voltage	V _{i-cs}	-1.5 to 0.3	V	
VREF pin current	I _{o-ref}	-20	mA	
VREF pin voltage	V _{ref}	-0.3 to V _{ref}	V	
Operating junction temperature	T _{j-opr}	-40 to +125	°C	6
Storage temperature	T _{stg}	-55 to +150	°C	

- Notes:
- Rated voltages are with reference to the GND (SGND, PGND) pin.
 - For rated currents, inflow to the IC is indicated by (+), and outflow by (-).
 - Shows the transient current when driving a capacitive load.
 - Group1 is the rated voltage for the following pins:
PFC-OUT, PWM-OUT
 - Group2 is the rated voltage for the following pins:
PFC-FB, PWM-CS, PWM-COMP, IAC, PFC-SS, PWM-SS, RT
 - HA16158P (DILP): $\theta_{ja} = 120^{\circ}\text{C/W}$
HA16158FP (SOP): $\theta_{ja} = 120^{\circ}\text{C/W}$
This value is based on actual measurements on a 10% wiring density glass epoxy circuit board (40 mm × 40 mm × 1.6 mm).

Electrical Characteristics

(Ta = 25°C, Vcc = 12 V, RT = 200 kΩ)

	Item	Symbol	Min	Typ	Max	Unit	Test Conditions
Supply	Start threshold	VH	15.0	16.0	17.0	V	
	Shutdown threshold	VL	9.4	10.0	10.6	V	
	UVLO hysteresis	dV _{UVL}	5.2	6.0	6.8	V	
	Start-up current	I _s	160	220	280	μA	V _{cc} = 14.8V
	I _s temperature stability	dI _s /dT _a	–	–0.3	–	%/°C	*1
	Operating current	I _{cc}	5.5	7.0	8.5	mA	I _{AC} = 0A, CL = 0F
	Shunt zenner voltage	V _z	25.5	27.5	29.5	V	I _{cc} = 14mA
	V _z temperature stability	dV _z /dT _a	–	–4	–	mV/°C	I _{cc} = 14mA *1
	Latch current	I _{LATCH}	180	250	320	μA	V _{cc} = 9V
VREF	Output voltage	V _{ref}	4.9	5.0	5.1	V	I _{source} = 1mA
	Line regulation	V _{ref-line}	–	5	20	mV	I _{source} = 1mA, V _{cc} = 12V to 23V
	Load regulation	V _{ref-load}	–	5	20	mV	I _{source} = 1mA to 20mA
	Temperature stability	dV _{ref}	–	80	–	ppm/°C	T _a = –40 to 125°C *1
Oscillator	Initial accuracy	f _{pwm}	117	130	143	kHz	Measured pin: PWM-OUT
		f _{pfc}	58.5	65	71.5	kHz	Measured pin: PFC-OUT
	f _{pwm} temperature stability	df _{pwm} /dT _a	–	±0.1	–	%/°C	T _a = –40 to 125°C *1
	f _{pwm} voltage stability	f _{pwm} (line)	–1.5	+0.5	+1.5	%	V _{CC} = 12V to 18V
	Ramp peak voltage	V _{ramp-H}	–	3.6	4.0	V	PFC *1
	Ramp valley voltage	V _{ramp-L}	–	0.65	–	V	PFC *1
	CT peak voltage	V _{ct-H}	–	3.2	–	V	PWM *1
	CT valley voltage	V _{ct-L}	1.50	1.60	–	V	PWM *1
	RT voltage	V _{rt}	0.85	1.00	1.15	V	Measured pin: RT
Supervisor	PFC on voltage	V _{on-pfc}	1.4	1.5	1.6	V	
	PFC off voltage	V _{off-pfc}	1.1	1.2	1.3	V	
	PFC on-off hysteresis	dV _{on-off}	0.2	0.3	0.4	V	
	Input current	I _{pfc-on}	–	0.1	1.0	μA	PFC-ON = 2V
	PFC OVP set voltage	V _{ovps-pfc}	2.65	2.80	2.95	V	Input pin: PFC-FB
	PFC OVP reset voltage	V _{ovpr-pfc}	2.45	2.60	2.75	V	Input pin: PFC-FB
	PFC OVP hysteresis	dV _{ovp}	0.10	0.20	0.30	V	
	B+ good voltage	V _{b-good}	2.25	2.40	2.55	V	Measured pin: PFC-FB
	B+ fail voltage	V _{b-fail}	1.4	1.5	1.6	V	Measured pin: PFC-FB
OVP latch	Latch threshold voltage	V _{latch}	3.76	4.00	4.24	V	Input pin: PWM-SS
	Latch reset voltage	V _{cc-res}	6.1	7.1	8.1	V	
Power saving for PWM	Power saving on voltage	V _{on-save}	1.53	1.70	1.87	V	Measured pin: PWM-COMP
	Minimum frequency at light load	f _{pwm-min}	–	2	–	kHz	PWM-COMP = 1.5V Measured pin: PWM-OUT *1

Note: 1. Reference values for design.

Electrical Characteristics (cont.)

(Ta = 25°C, Vcc = 12 V, RT = 200 kΩ)

Item		Symbol	Min	Typ	Max	Unit	Test Conditions
Soft start for PWM	Soft start time	tss-pwm	–	4.2	–	ms	PWM-SS = 0V to Vct-h *1
	Source current	Iss-pwm	–20.0	–25.0	–30.0	μA	Measured pin: PWM-SS
	High voltage	Vh-ss	3.25	3.5	3.75	V	Measured pin: PWM-SS
Soft start for PFC	Soft start time	tss-pfc	–	5.7	–	ms	PFC-SS = Vref to Vramp-I *1
	Source current	Iss-pfc	+20.0	+25.0	+30.0	μA	Measured pin: PFC-SS
PWM current sense	Delay to output	td-cs	–	210	300	ns	PWM-EO = 5V, PWM-CS = 0 to 2V
PFC current limit	Threshold voltage	VLM1	–0.45	–0.50	–0.55	V	PFC-ON = 2V
	Threshold voltage	VLM2	–0.22	–0.25	–0.28	V	PFC-ON = 4V
	Delay to output	td-LM	–	280	500	ns	PFC-CS = 0 to –1V
PFC-VAMP	Feedback voltage	Vfb-pfc	2.45	2.50	2.55	V	PFC-EO = 2.5V
	Input bias current	Ifb-pfc	–0.3	0	0.3	μA	Measured pin: PFC-FB
	Open loop gain	Av-pfc	–	65	–	dB	*1
	High voltage	Veoh-pfc	5.0	5.7	6.4	V	PFC-FB = 2.3V, PFC-EO: Open
	Low voltage	Veol-pfc	–	0.1	0.3	V	PFC-FB = 2.7V, PFC-EO: Open
	Source current	Isrc-pfc	–	–90	–	μA	PFC-FB = 1.0V, PFC-EO: 2.5V *1
	Sink current	Isnk-pfc	–	90	–	μA	PFC-FB = 4.0V, PFC-EO: 2.5V *1
	Transconductance	Gm-pfcv	150	200	250	μA/V	PFC-FB = 2.5V, PFC-EO: 2.5V
PFC-OUT	Minimum duty cycle	Dmin-pfc	–	–	0	%	CAO = 4.0V
	Maximum duty cycle	Dmax-pfc	90	95	98	%	CAO = 0V
	Rise time	tr-pfc	–	30	100	ns	CL = 1000pF
	Fall time	tf-pfc	–	30	100	ns	CL = 1000pF
	Peak current	Ipk-pfc	–	1.0	–	A	CL = 0.01μF *1
	Low voltage	Vol1-pfc	–	0.05	0.2	V	Iout = 20mA
		Vol2-pfc	–	0.5	2.0	V	Iout = 200mA
		Vol3-pfc	–	0.03	0.7	V	Iout = 10mA, VCC = 5V
	High voltage	Voh1-pfc	11.5	11.9	–	V	Iout = –20mA
Voh2-pfc		10.0	11.0	–	V	Iout = –200mA	
PWM-OUT	Minimum duty cycle	Dmin-pwm	–	–	0	%	PWM-COMP = 0V
	Maximum duty cycle	Dmax-pwm	42	45	49	%	PWM-COMP = Vref
	Rise time	tr-pwm	–	30	100	ns	CL = 1000pF
	Fall time	tf-pwm	–	30	100	ns	CL = 1000pF
	Peak current	Ipk-pwm	–	1.0	–	A	CL = 0.01μF *1
	Low voltage	Vol1-pwm	–	0.05	0.2	V	Iout = 20mA
		Vol2-pwm	–	0.5	2.0	V	Iout = 200mA
		Vol3-pwm	–	0.03	0.7	V	Iout = 10mA, VCC = 5V
	High voltage	Voh1-pwm	11.5	11.9	–	V	Iout = –20mA
Voh2-pwm		10.0	11.0	–	V	Iout = –200mA	

Note: 1. Reference values for design.

Electrical Characteristics (cont.)

(Ta = 25°C, Vcc = 12 V, RT = 200 kΩ)

Item	Symbol	Min	Typ	Max	Unit	Test Conditions	
PFC-CAMP	Input offset voltage	Vio-ca	-	±7	-	mV *1	
	Open loop gain	Av-ca	-	65	-	dB *1	
	High voltage	Veoh-ca	5.0	5.7	6.4	V	
	Low voltage	Veol-ca	-	0.1	0.3	V	
	Source current	Isrc-ca	-	-90	-	μA	CAO = 2.5V *1
	Sink current	Isnk-ca	-	90	-	μA	CAO = 2.5V *1
	Transconductance	Gm-pfcc	150	200	250	μA/V	*1
IAC/Multiplier	IAC pin voltage	Viac	0.7	1.0	1.3	V	IAC = 100μA
	Terminal offset current	Imo-offset1	-67	-90	-113	μA	IAC = 0A, PFC-ON = 2V
		Imo-offset2	-60	-80	-100	μA	IAC = 0A, PFC-ON = 4V
	Output current (PFC-ON = 2.0V)	Imo1	-	-20	-	μA	PFC-EO = 2V, IAC = 100μA *1, 2
		Imo2	-	-60	-	μA	PFC-EO = 4V, IAC = 100μA *1, 2
	Output current (PFC-ON = 4.0V)	Imo3	-	-5	-	μA	PFC-EO = 2V, IAC = 100μA *1, 2
Imo4		-	-15	-	μA	PFC-EO = 4V, IAC = 100μA *1, 2	
PFC-CS resistance	Rmo	-	3.3	-	kΩ	*1	
Gain selector	Threshold voltage for K = 0.05	VK-H	3.60	3.80	4.00	V	Measured pin: PFC-ON
	Threshold voltage for K = 0.25	VK-L	3.20	3.40	3.60	V	Measured pin: PFC-ON
	VK hysteresis	dVK	0.30	0.40	0.50	V	*1

- Notes: 1. Reference values for design.
 2. Imo1 to Imo4 are defined as:
 $Imo = (PFC-CS \text{ pin current}) - (Imo\text{-offset})$

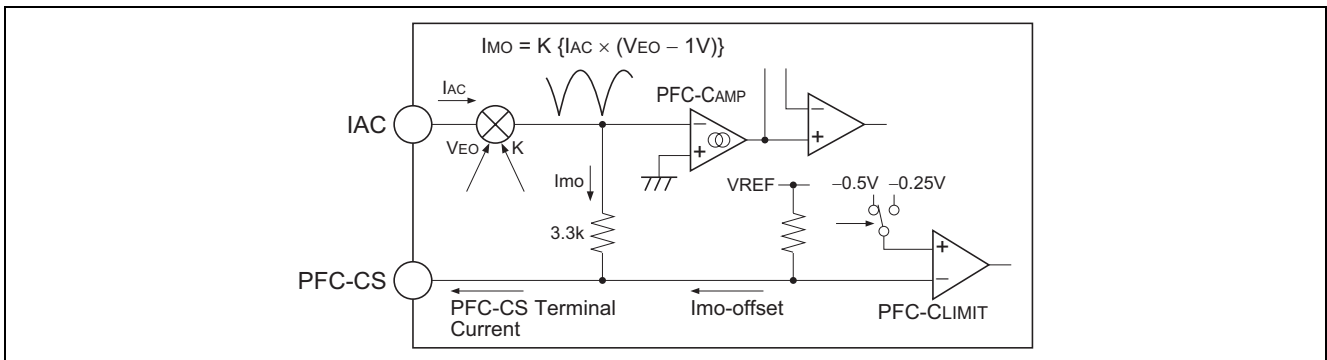

Timing Diagram

1. Start-up Timing

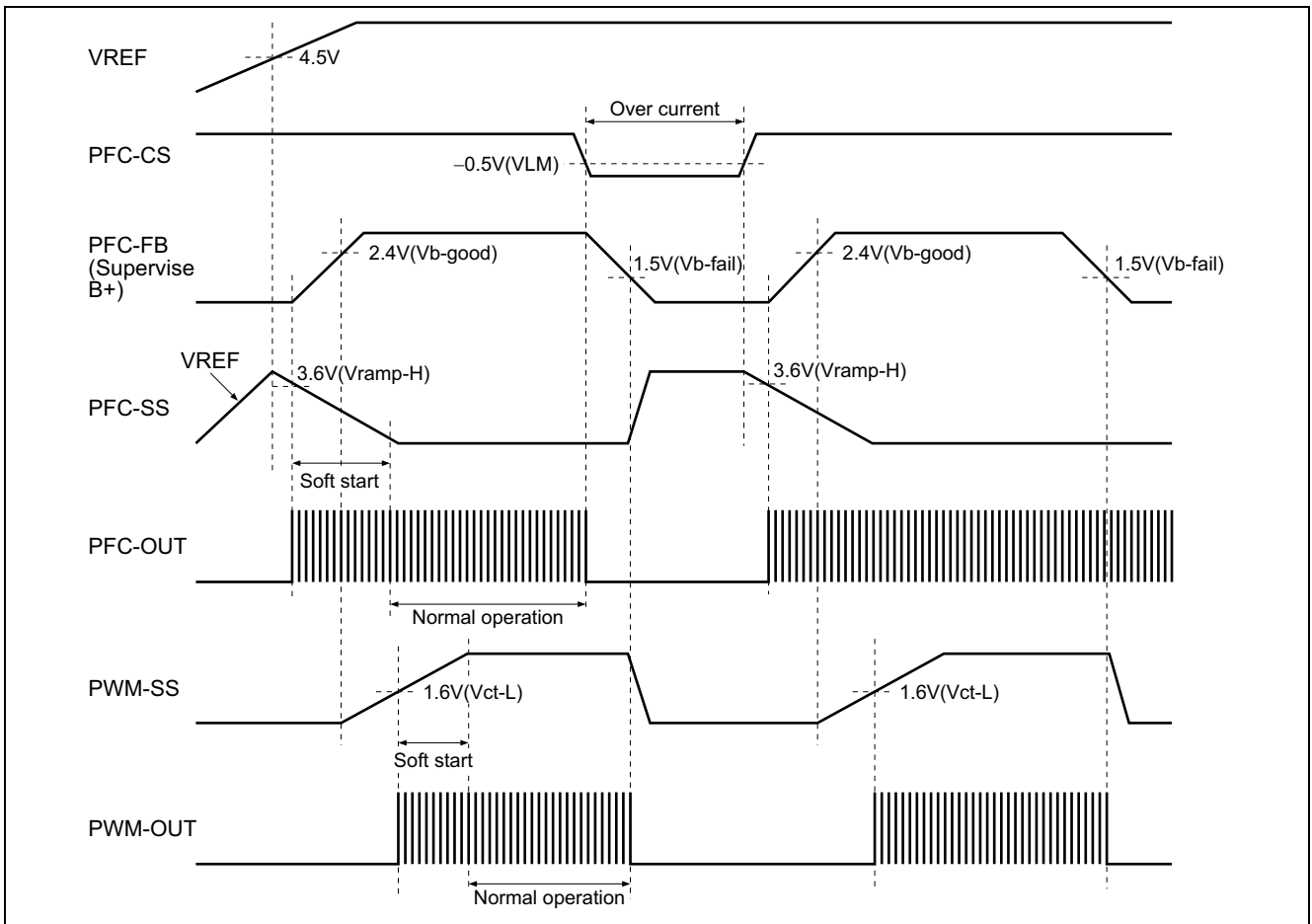

2. PWM OVP Latch

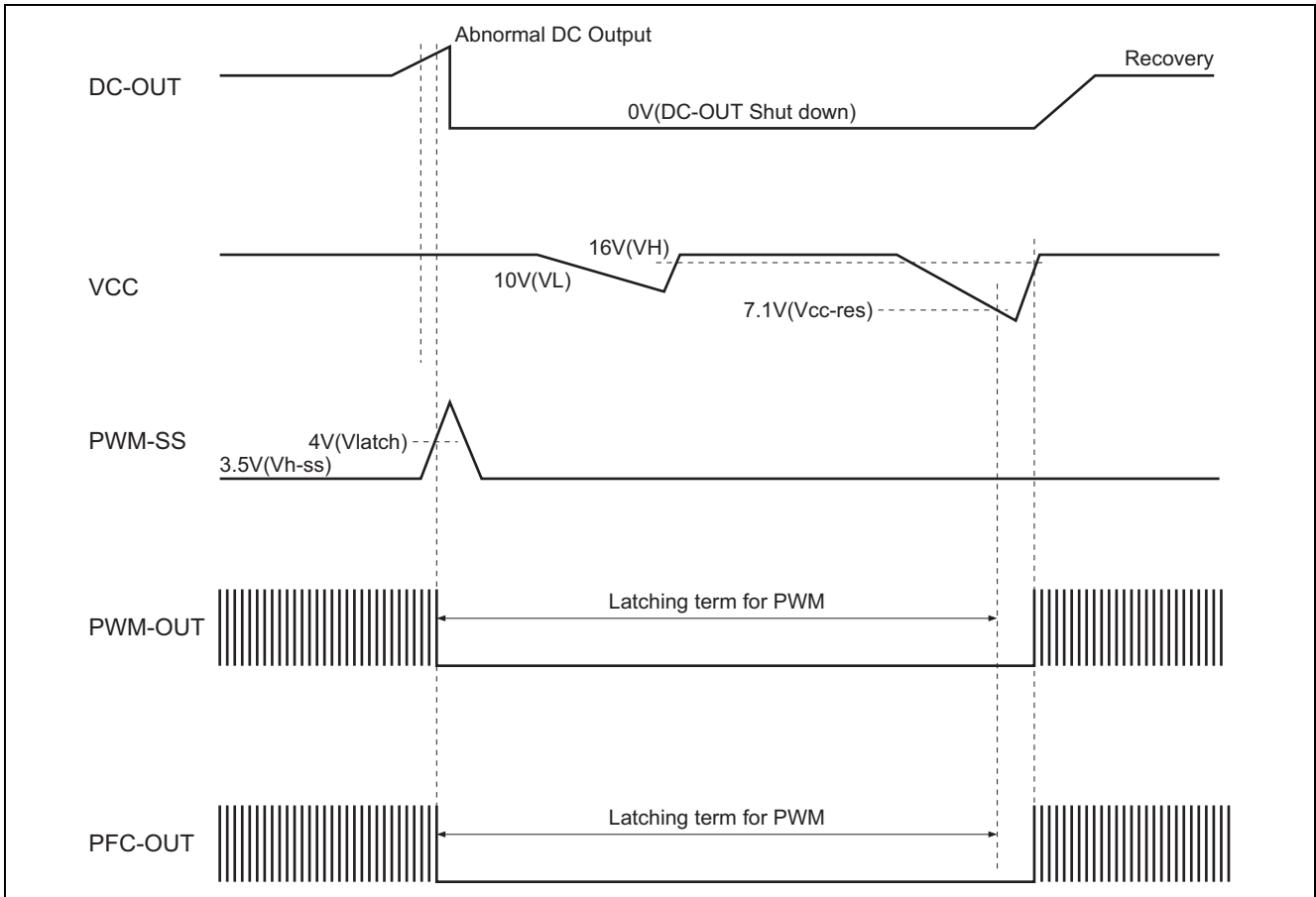

3. PWM Power Saving

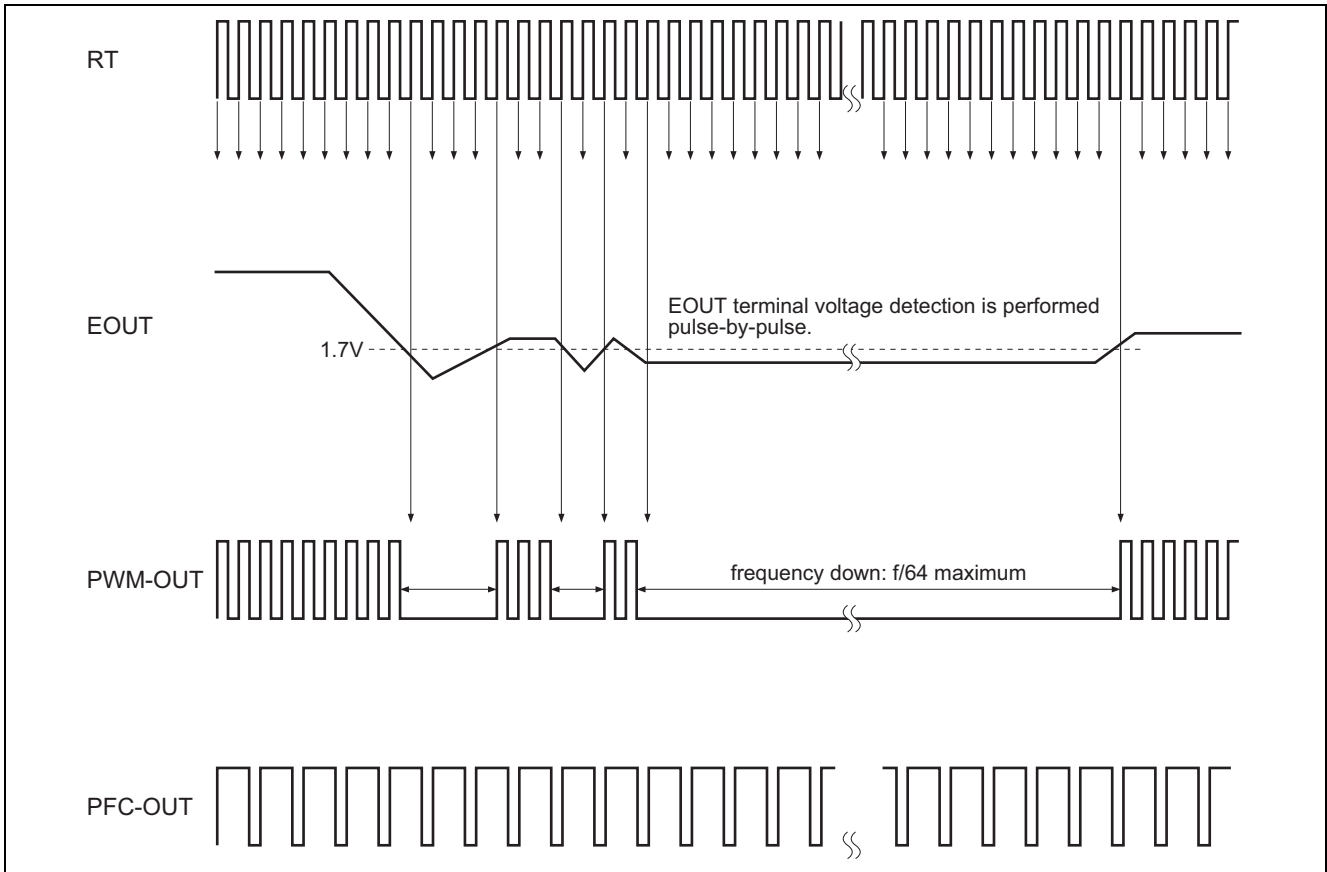

Functional Description

1. UVL Circuit

The UVL circuit monitors the Vcc voltage and halts operation of the IC in the event of a low voltage.

The voltage for detecting Vcc has a hysteresis characteristic, with 16.0 V as the start threshold and 10.0 V as the shutdown threshold.

When the IC has been halted by the UVL circuit, control is performed to fix driver circuit output low and halt VREF output and the oscillator.

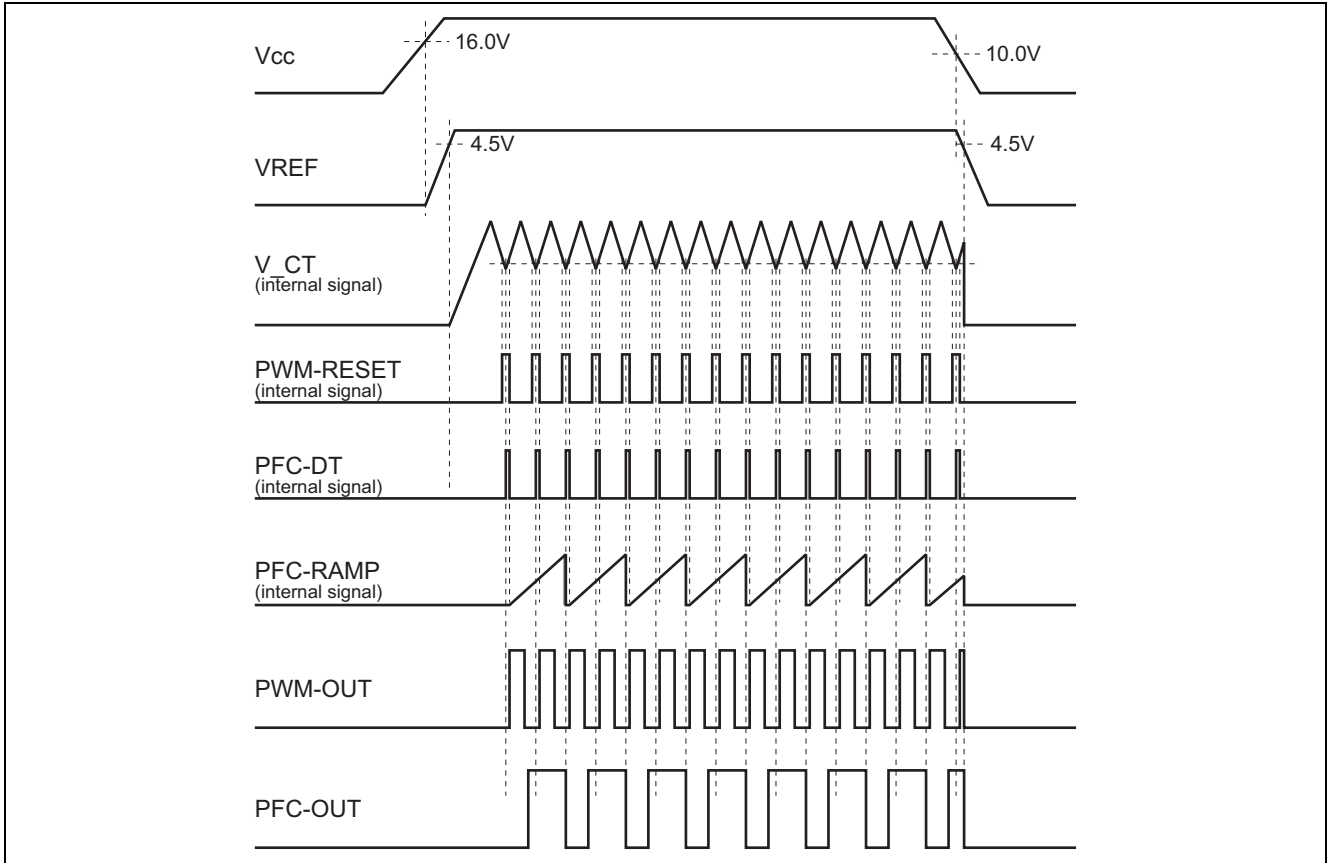

Figure 1

2. Soft Start Circuit (for PWM Control)

This function gradually increases the pulse width of the PWM-OUT pin from a 0% duty cycle at start-up to prevent a sudden increase in the pulse width that may cause problems such as transient stress on external parts or overshoot of the secondary-side output voltage.

The soft start time can easily be set with a single external capacitance.

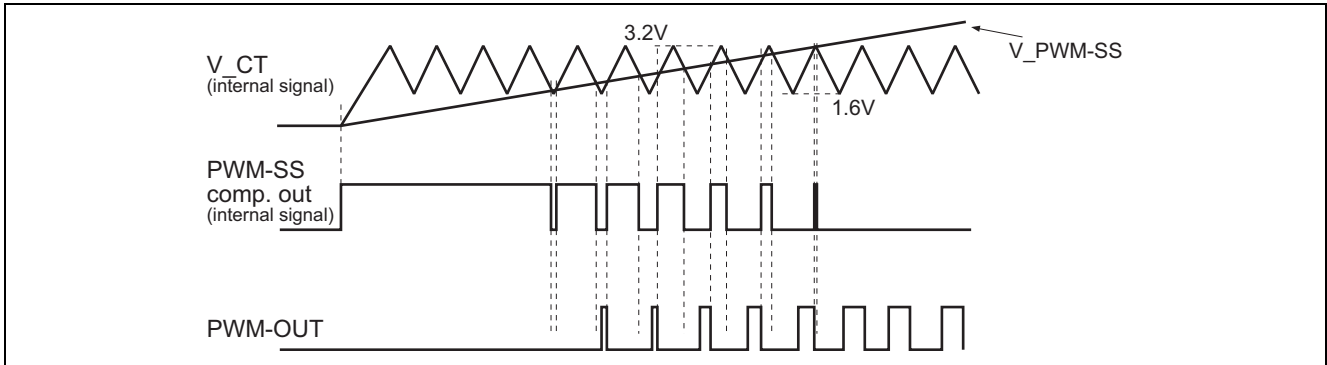

Figure 2

Soft start time t_{ss-pwm} is determined by PWM-SS pin connection capacitance C_{ss-pwm} and an internal constant, and can be estimated using the equation shown below.

Soft start time t_{ss-pwm} is the time until the PWM-SS pin voltage reaches upper-end voltage 3.2 V of the IC-internal CT voltage waveform after VREF starts up following UVLO release.

Soft start time t_{ss-pwm} when C_{ss-pwm} is 3.3 nF is given by the following equation.

$$t_{ss-pwm} = \frac{C_{ss-pwm} \times V_{ct-H}}{I_{ss-pwm}} = \frac{33 \text{ [nF]} \times 3.2 \text{ [V]}}{25 \text{ [\mu A]}}$$

$$\approx 4.2 \text{ [ms]}$$

* I_{ss-pwm} : PWM-SS pin source current, 25 μA typ.

3. Soft Start Circuit (for PFC Control)

This function gradually increases the pulse width of the PFC-OUT pin from a 0% duty cycle at start-up to prevent a sudden increase in the pulse width that may cause problems such as transient stress on external parts or overshoot of the PFC output voltage (B+ voltage).

The soft start time can easily be set with a single external capacitance.

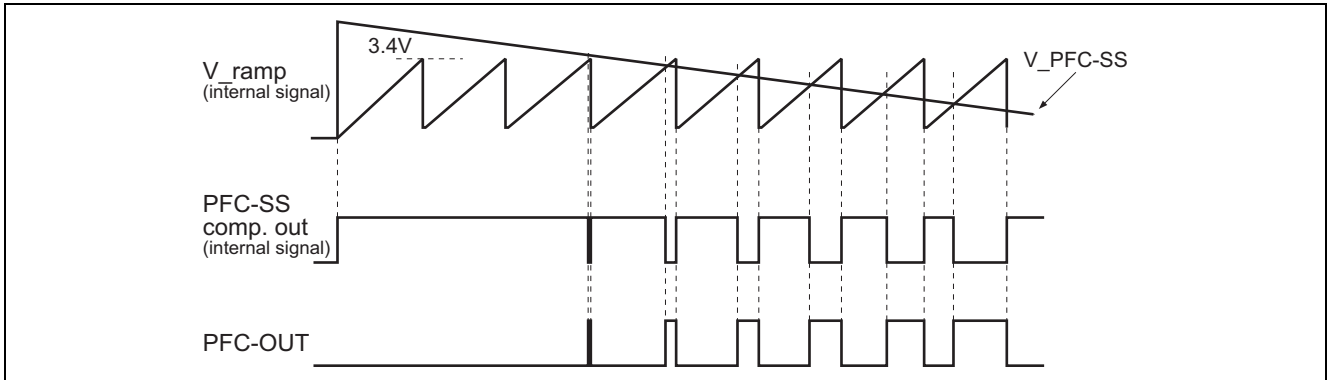

Figure 3

Soft start time t_{ss-pfc} is determined by PFC-SS pin connection capacitance C_{ss-pfc} and an internal constant, and can be estimated using the equation shown below.

Soft start time t_{ss-pfc} is the time until the PFC-SS pin voltage reaches lower-end voltage 0.65 V of the IC-internal RAMP voltage waveform after VREF starts up following UVLO release.

Soft start time t_{ss-pfc} when C_{ss-pfc} is 3.3 nF is given by the following equation.

$$t_{ss-pfc} = \frac{C_{ss-pfc} \times (V_{REF} - V_{ramp-L})}{I_{ss-pwm}} = \frac{33 \text{ [nF]} \times (5 - 0.65)}{25 \text{ [\mu A]}}$$

$$\approx 5.7 \text{ [ms]}$$

* I_{ss-pfc} : PFC-SS pin sink current, 25 μA typ.

In addition, when you do not use a soft start function, please ground this terminal.

4. PFC On/Off Function

On/off control of the PFC function can be performed using the PFC-ON pin.

If an AC voltage that has undergone primary rectification and has been divided by an external resistance is input, it is possible to halt PFC operation in the event of a low input voltage. On/off control is also possible by using a logic signal.

When the PFC function is turned on/off by using the PFC-ON pin, however, the PFC-SS pin cannot be reset. Therefore, a soft start is not operated at the start-up by the PFC-ON pin.

The figure below illustrates an example of circuit for simultaneous reset of the PFC-SS pin and PWM-SS pin.

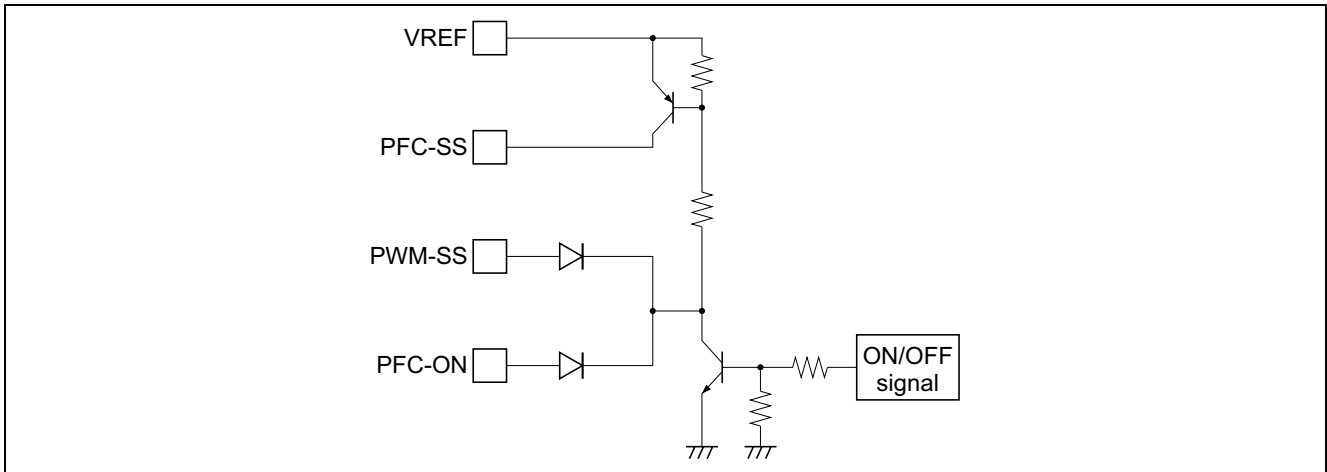

Figure 4 Example of Circuit Configuration to Turn On/Off PFC & PWM Functions

This IC also incorporates a function that automatically detects a 100 V system or 200 V system AC voltage at the PFC-ON pin, and switches multiplier gain and the PFC-CS comparison voltage.

These functions simplify the design of a power supply compatible with worldwide input.

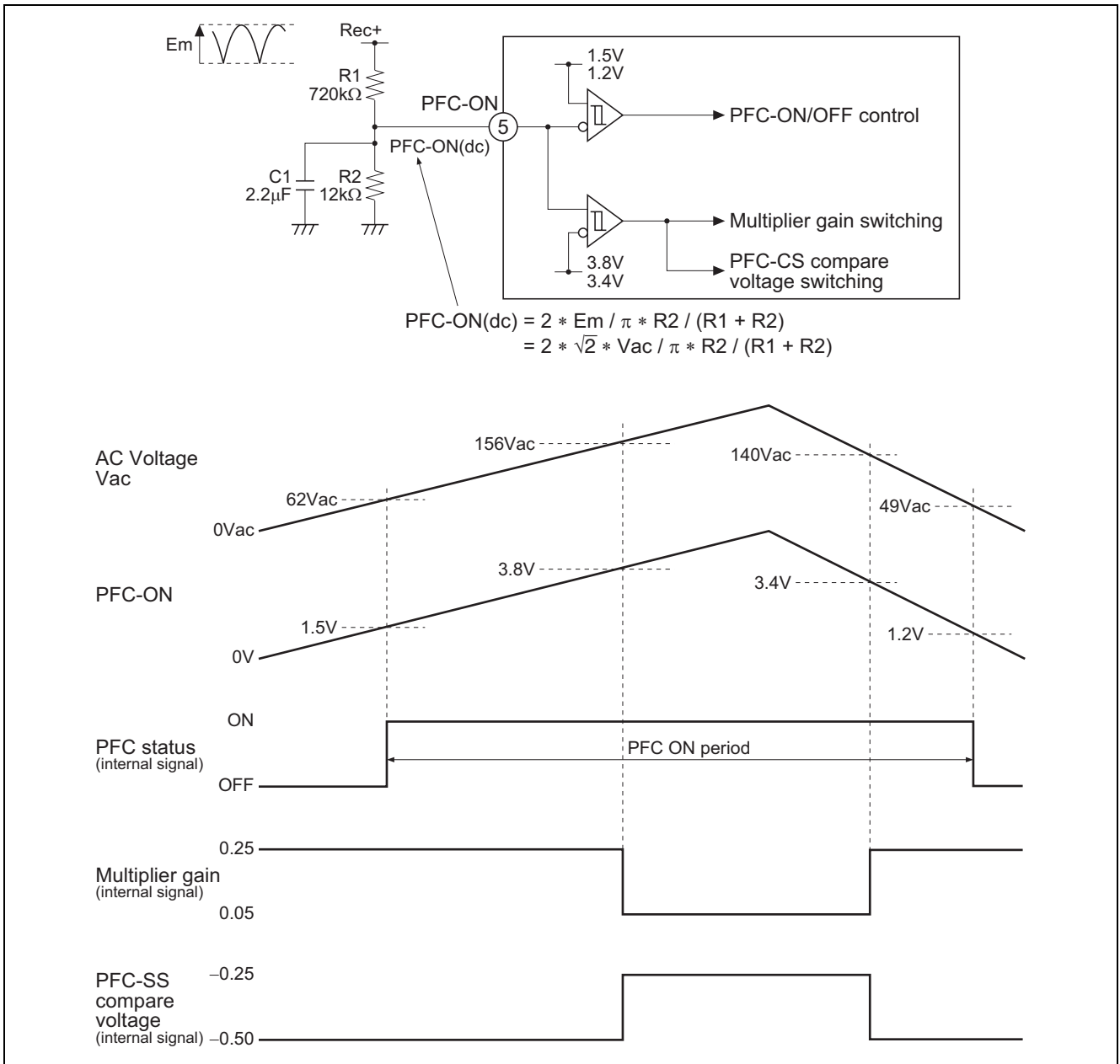

Figure 5

5. Power Saving in Standby State (for PWM Control)

When the output load is light, as in the standby state, the operating frequency of the PWM control section is automatically decreased in order to reduce switching loss.

Standby detection is performed by monitoring the PWM-COMP voltage, and the operating frequency is decreased to a maximum of 1/64 of the reference frequency determined by an external timing resistance.

As standby detection is performed on a reference frequency pulse-by-pulse basis, the frequency varies gently according to the output load.

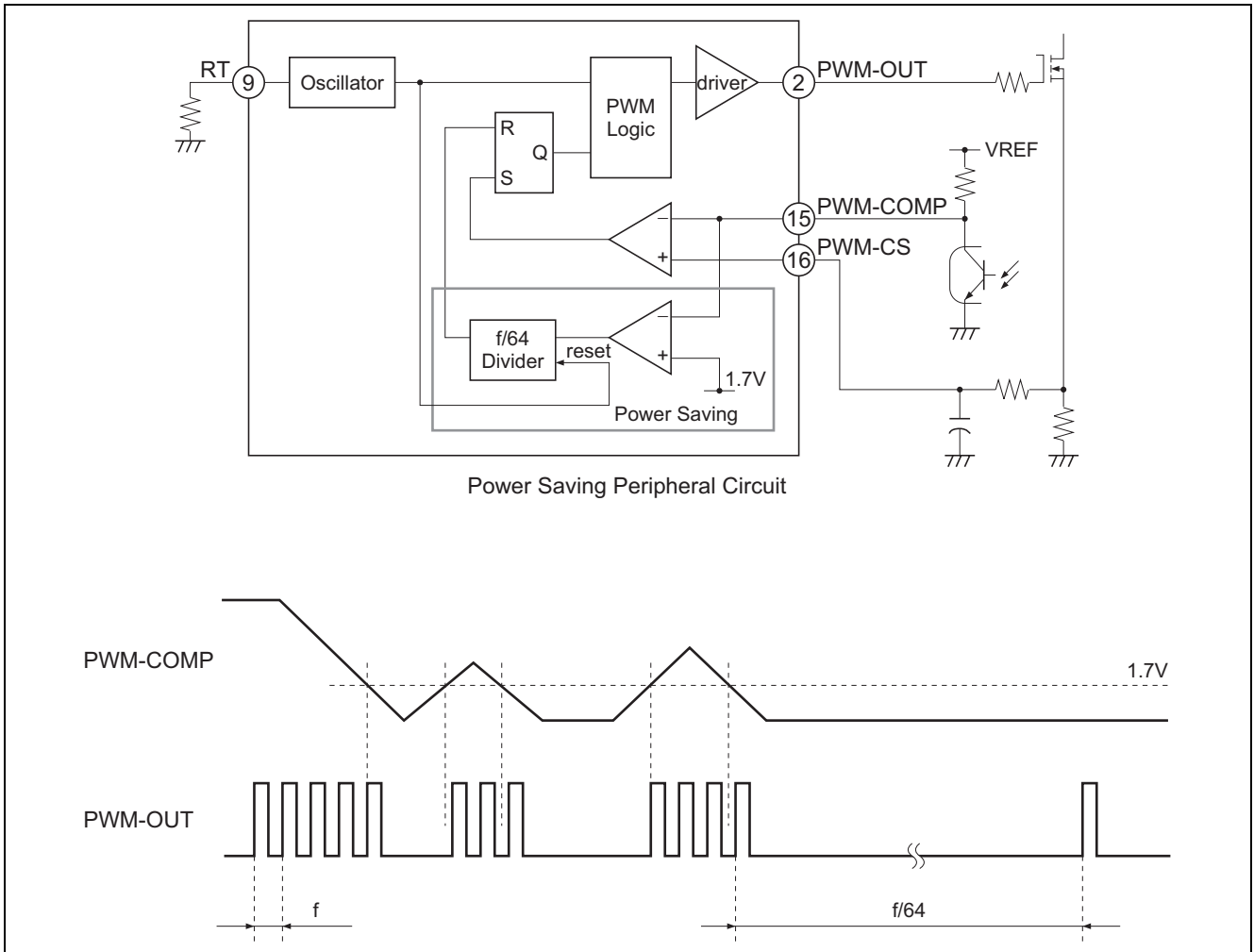

Figure 6

6. Overvoltage Latch Protection (for PWM Control)

This is a protection function that halts PWM-OUT and PFC-OUT if the secondary-side PWM output voltage is abnormally high.

Overvoltage signal input is shared with the PWM-SS pin. When this pin is pulled up to 4.0 V or higher, the control circuit identifies an overvoltage error and halts PWM-OUT and PFC-OUT.

The power supply is turned off, and the latch is released when the VCC voltage falls to 7.1 V or below.

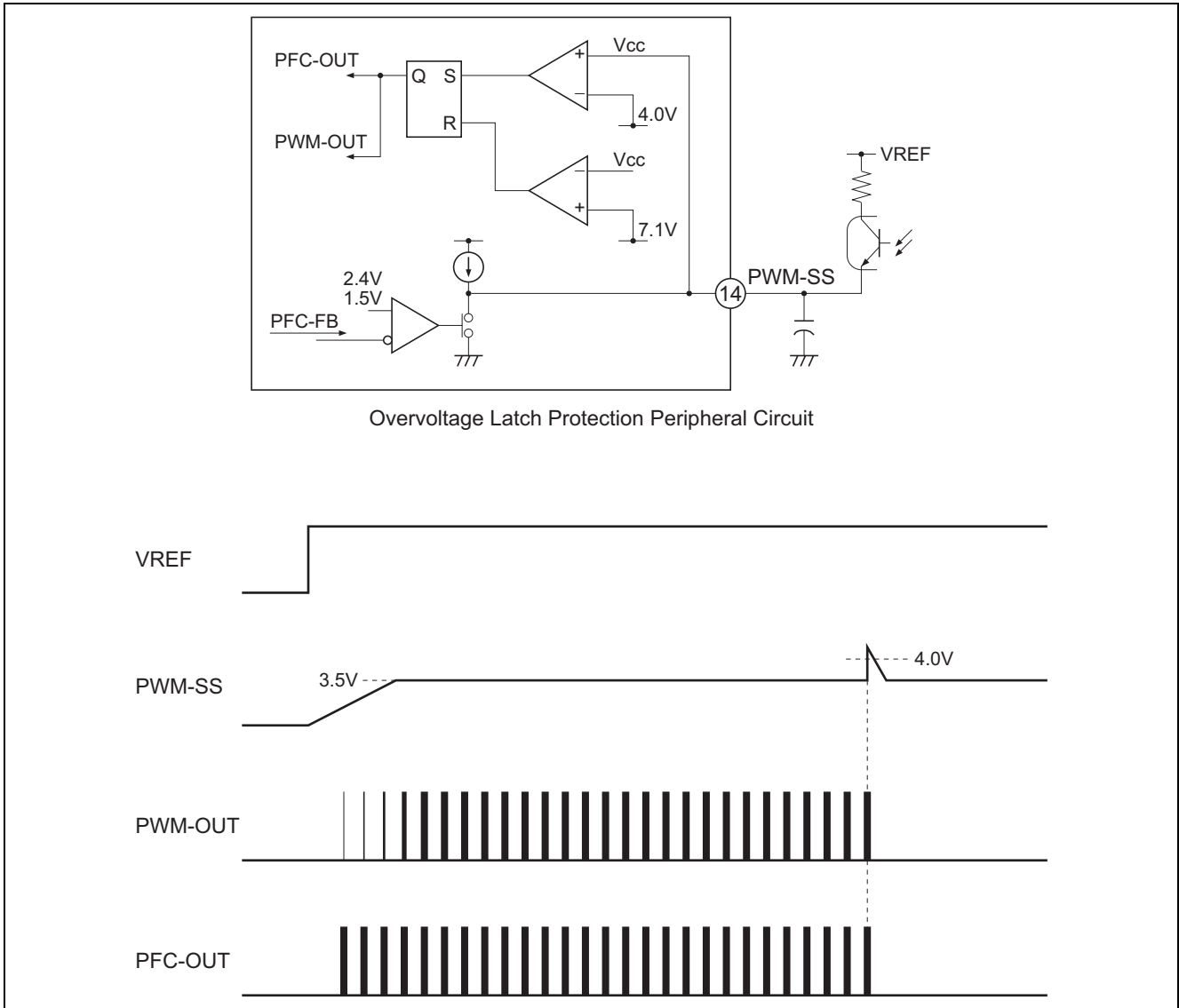

Figure 7

7. Operating Frequency

The operating frequency is adjusted by timing resistance RT.

Adjustment examples are shown in the graph below. The operating frequency fpwm in the PWM section is determined by the RT. The operating frequency fpfc in the PFC section is half the value of fpwm.

The operating frequency in the PWM section can be estimated using the approximate equation shown below.
 RT = 200 kΩ:

$$fpwm \approx \frac{2.60 \times 10^{10}}{RT} = 130 \text{ [kHz]}$$

$$fpfc = \frac{fpwm}{2} = 65 \text{ [kHz]}$$

This is only an approximate equation, and the higher the frequency, the greater will be the degree of error of the approximate equation due to the effects of the delay time in the internal circuit, etc.

When the operating frequency is adjusted, it is essential to confirm operation using the actual system.

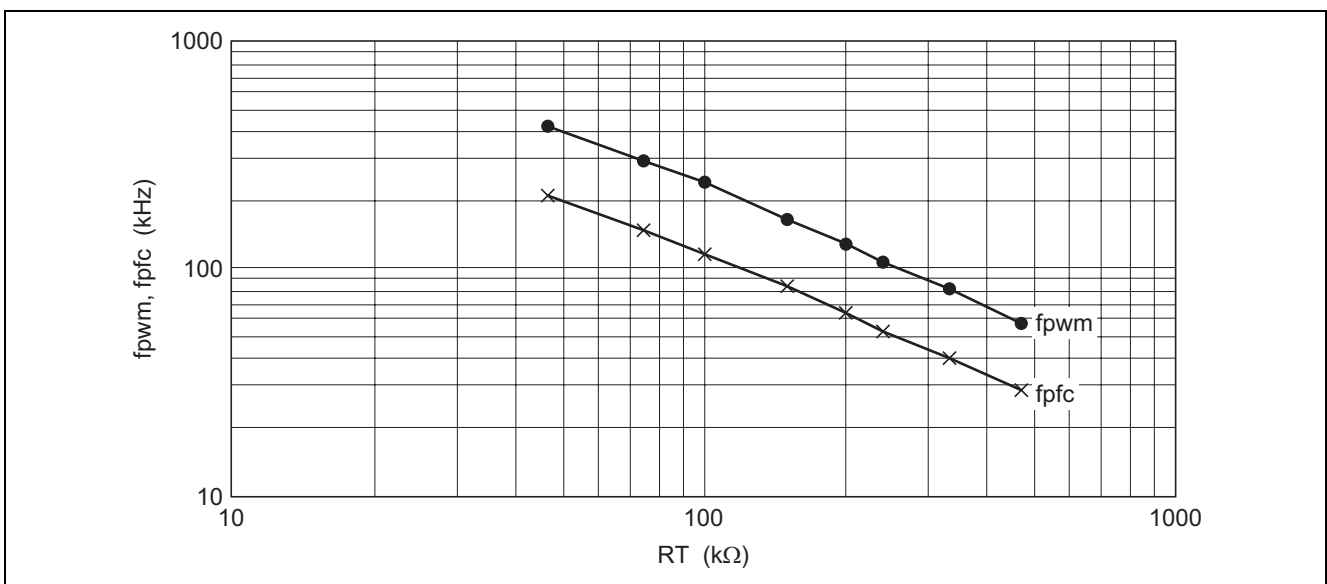
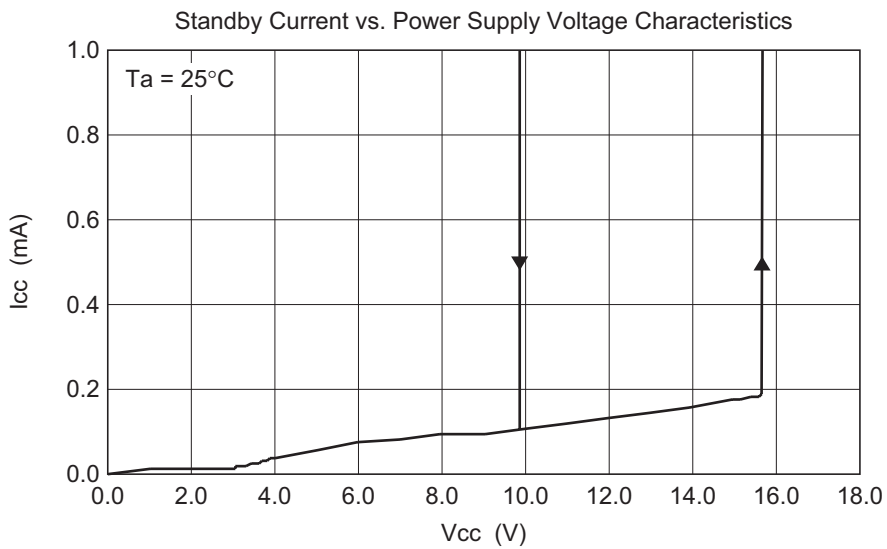
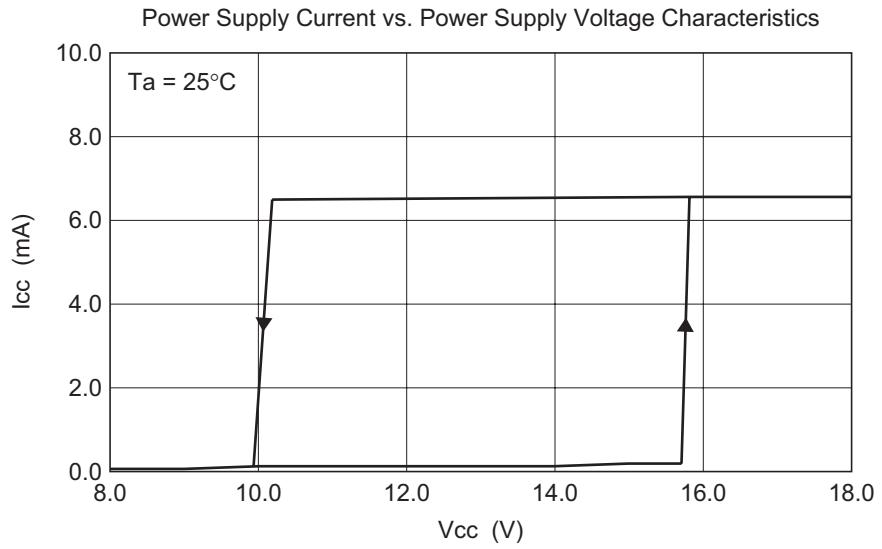
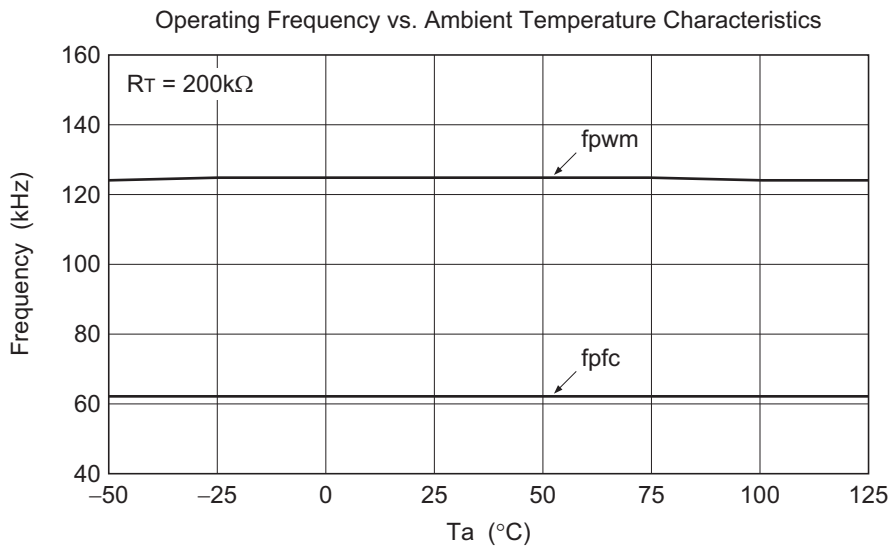
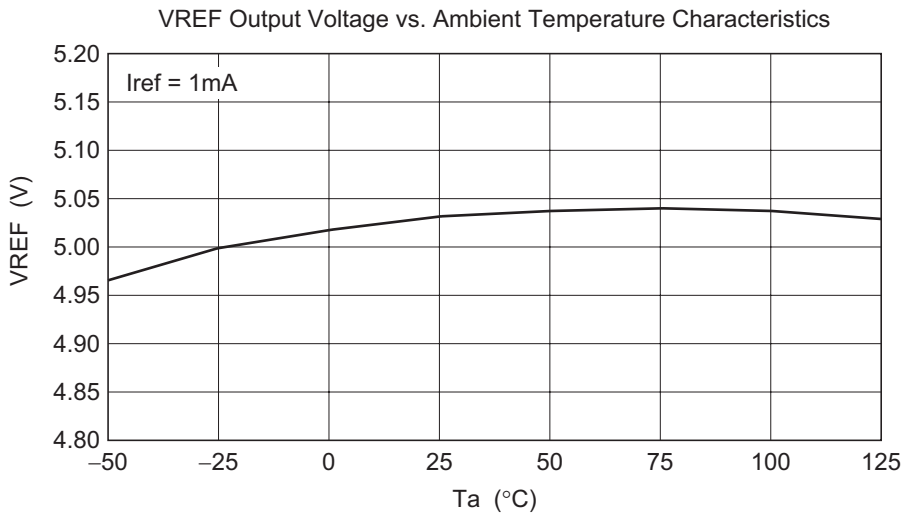
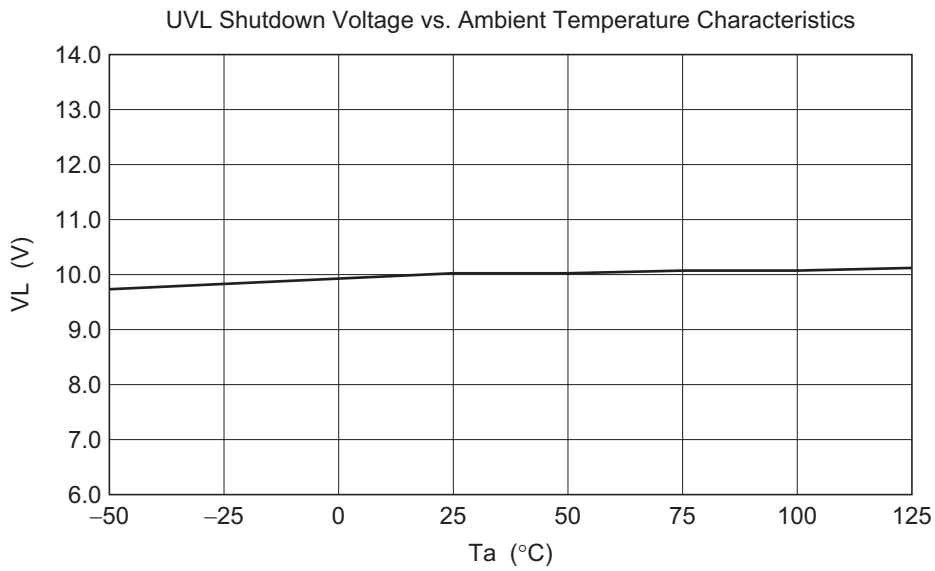
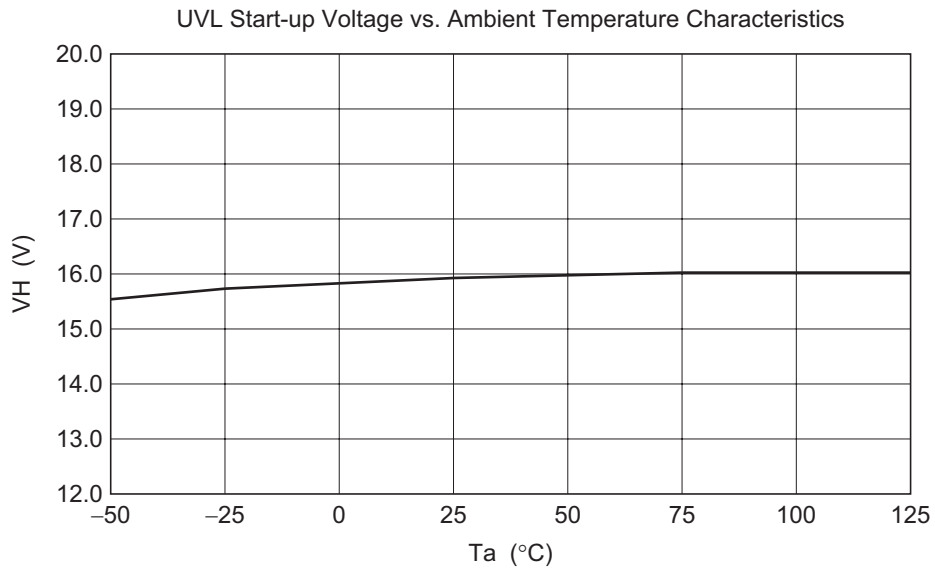

Figure 8

Characteristic Curves







Application Circuit Example

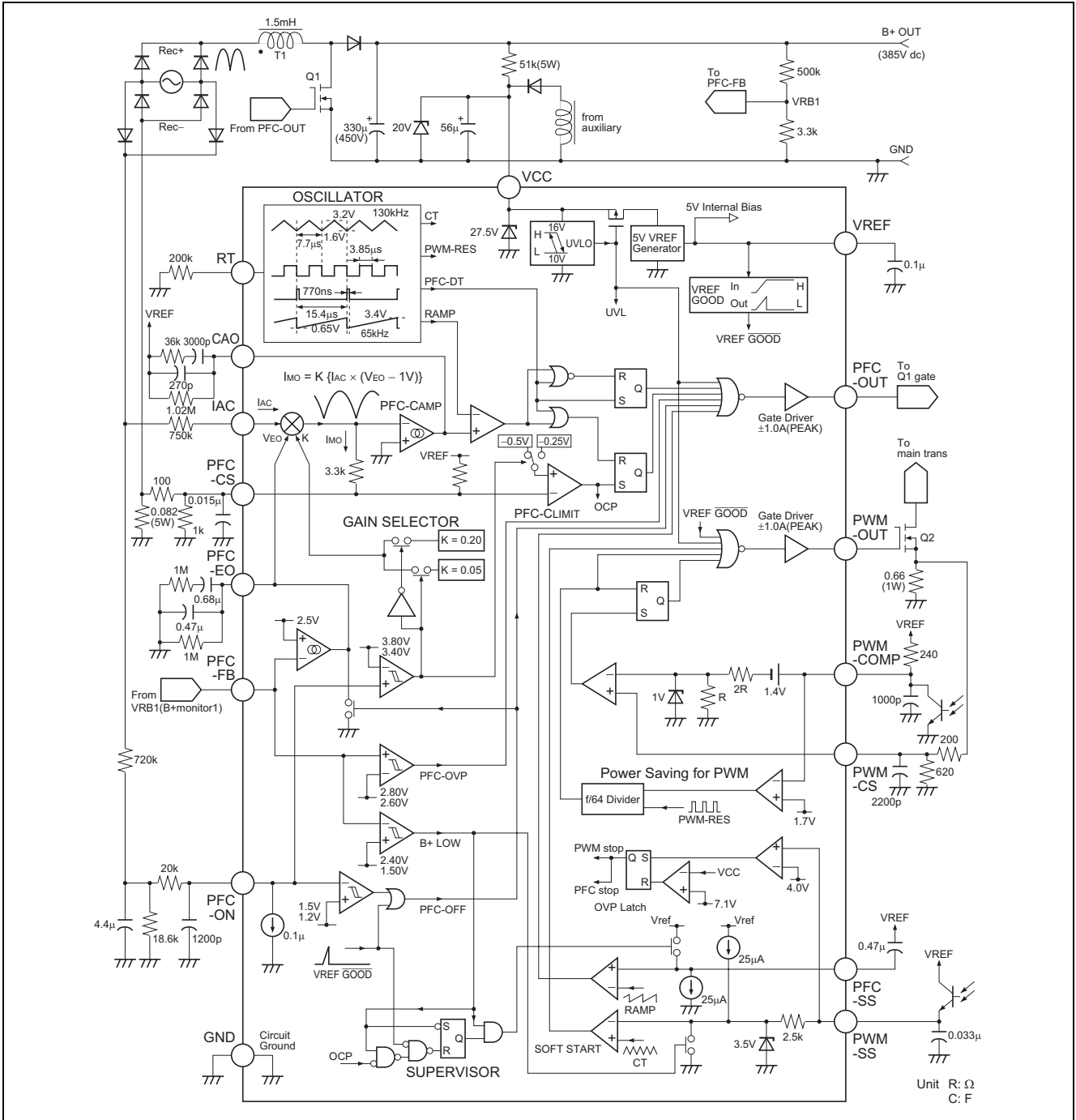

Package Dimensions

As of January, 2003
Unit: mm

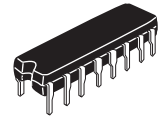
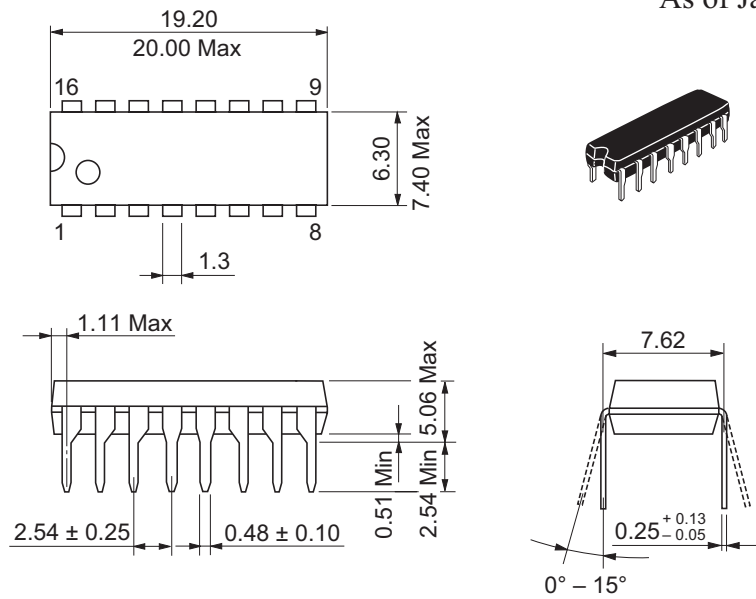

Package Code	DP-16
JEDEC	Conforms
JEITA	Conforms
Mass (reference value)	1.07 g

JEITA Package Code	RENESAS Code	Previous Code	MASS[Typ.]
P-SOP16-5.5x10.06-1.27	PRSP0016DH-A	FP-16DA	0.24g

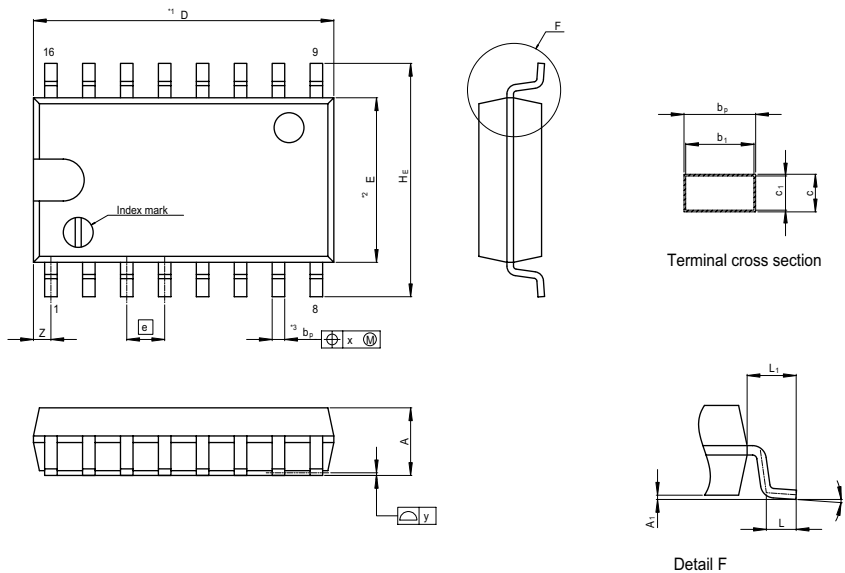

NOTE)
1. DIMENSIONS**1 (Nom)**AND**2*
DO NOT INCLUDE MOLD FLASH.
2. DIMENSION**3*DOES NOT
INCLUDE TRIM OFFSET.

Reference Symbol	Dimension in Millimeters		
	Min	Nom	Max
D	—	10.06	10.5
E	—	5.5	—
A ₂	—	—	—
A ₁	0.00	0.10	0.20
A	—	—	2.20
b _p	0.34	0.42	0.50
b ₁	—	0.40	—
c	0.17	0.22	0.27
c ₁	—	0.20	—
θ	0°	—	8°
H _E	7.50	7.80	8.00
e	—	1.27	—
x	—	—	0.12
y	—	—	0.15
Z	—	—	0.80
L	0.50	0.70	0.90
L ₁	—	1.15	—

Notes:

1. This document is provided for reference purposes only so that Renesas customers may select the appropriate Renesas products for their use. Renesas neither makes warranties or representations with respect to the accuracy or completeness of the information contained in this document nor grants any license to any intellectual property rights or any other rights of Renesas or any third party with respect to the information in this document.
2. Renesas shall have no liability for damages or infringement of any intellectual property or other rights arising out of the use of any information in this document, including, but not limited to, product data, diagrams, charts, programs, algorithms, and application circuit examples.
3. You should not use the products or the technology described in this document for the purpose of military applications such as the development of weapons of mass destruction or for the purpose of any other military use. When exporting the products or technology described herein, you should follow the applicable export control laws and regulations, and procedures required by such laws and regulations.
4. All information included in this document such as product data, diagrams, charts, programs, algorithms, and application circuit examples, is current as of the date this document is issued. Such information, however, is subject to change without any prior notice. Before purchasing or using any Renesas products listed in this document, please confirm the latest product information with a Renesas sales office. Also, please pay regular and careful attention to additional and different information to be disclosed by Renesas such as that disclosed through our website. (<http://www.renesas.com>)
5. Renesas has used reasonable care in compiling the information included in this document, but Renesas assumes no liability whatsoever for any damages incurred as a result of errors or omissions in the information included in this document.
6. When using or otherwise relying on the information in this document, you should evaluate the information in light of the total system before deciding about the applicability of such information to the intended application. Renesas makes no representations, warranties or guaranties regarding the suitability of its products for any particular application and specifically disclaims any liability arising out of the application and use of the information in this document or Renesas products.
7. With the exception of products specified by Renesas as suitable for automobile applications, Renesas products are not designed, manufactured or tested for applications or otherwise in systems the failure or malfunction of which may cause a direct threat to human life or create a risk of human injury or which require especially high quality and reliability such as safety systems, or equipment or systems for transportation and traffic, healthcare, combustion control, aerospace and aeronautics, nuclear power, or undersea communication transmission. If you are considering the use of our products for such purposes, please contact a Renesas sales office beforehand. Renesas shall have no liability for damages arising out of the uses set forth above.
8. Notwithstanding the preceding paragraph, you should not use Renesas products for the purposes listed below:
 - (1) artificial life support devices or systems
 - (2) surgical implantations
 - (3) healthcare intervention (e.g., excision, administration of medication, etc.)
 - (4) any other purposes that pose a direct threat to human lifeRenesas shall have no liability for damages arising out of the uses set forth in the above and purchasers who elect to use Renesas products in any of the foregoing applications shall indemnify and hold harmless Renesas Technology Corp., its affiliated companies and their officers, directors, and employees against any and all damages arising out of such applications.
9. You should use the products described herein within the range specified by Renesas, especially with respect to the maximum rating, operating supply voltage range, movement power voltage range, heat radiation characteristics, installation and other product characteristics. Renesas shall have no liability for malfunctions or damages arising out of the use of Renesas products beyond such specified ranges.
10. Although Renesas endeavors to improve the quality and reliability of its products, IC products have specific characteristics such as the occurrence of failure at a certain rate and malfunctions under certain use conditions. Please be sure to implement safety measures to guard against the possibility of physical injury, and injury or damage caused by fire in the event of the failure of a Renesas product, such as safety design for hardware and software including but not limited to redundancy, fire control and malfunction prevention, appropriate treatment for aging degradation or any other applicable measures. Among others, since the evaluation of microcomputer software alone is very difficult, please evaluate the safety of the final products or system manufactured by you.
11. In case Renesas products listed in this document are detached from the products to which the Renesas products are attached or affixed, the risk of accident such as swallowing by infants and small children is very high. You should implement safety measures so that Renesas products may not be easily detached from your products. Renesas shall have no liability for damages arising out of such detachment.
12. This document may not be reproduced or duplicated, in any form, in whole or in part, without prior written approval from Renesas.
13. Please contact a Renesas sales office if you have any questions regarding the information contained in this document, Renesas semiconductor products, or if you have any other inquiries.



RENESAS SALES OFFICES

<http://www.renesas.com>

Refer to "<http://www.renesas.com/en/network>" for the latest and detailed information.

Renesas Technology America, Inc.

450 Holger Way, San Jose, CA 95134-1368, U.S.A
Tel: <1> (408) 382-7500, Fax: <1> (408) 382-7501

Renesas Technology Europe Limited

Dukes Meadow, Millboard Road, Bourne End, Buckinghamshire, SL8 5FH, U.K.
Tel: <44> (1628) 585-100, Fax: <44> (1628) 585-900

Renesas Technology (Shanghai) Co., Ltd.

Unit 204, 205, AZIACenter, No.1233 Lujiazui Ring Rd, Pudong District, Shanghai, China 200120
Tel: <86> (21) 5877-1818, Fax: <86> (21) 6887-7898

Renesas Technology Hong Kong Ltd.

7th Floor, North Tower, World Finance Centre, Harbour City, 1 Canton Road, Tsimshatsui, Kowloon, Hong Kong
Tel: <852> 2265-6688, Fax: <852> 2730-6071

Renesas Technology Taiwan Co., Ltd.

10th Floor, No.99, Fushing North Road, Taipei, Taiwan
Tel: <886> (2) 2715-2888, Fax: <886> (2) 2713-2999

Renesas Technology Singapore Pte. Ltd.

1 Harbour Front Avenue, #06-10, Keppel Bay Tower, Singapore 098632
Tel: <65> 6213-0200, Fax: <65> 6278-8001

Renesas Technology Korea Co., Ltd.

Kukje Center Bldg. 18th Fl., 191, 2-ka, Hangang-ro, Yongsan-ku, Seoul 140-702, Korea
Tel: <82> (2) 796-3115, Fax: <82> (2) 796-2145

Renesas Technology Malaysia Sdn. Bhd

Unit 906, Block B, Menara Amcorp, Amcorp Trade Centre, No.18, Jalan Persiaran Barat, 46050 Petaling Jaya, Selangor Darul Ehsan, Malaysia
Tel: <603> 7955-9390, Fax: <603> 7955-9510