

# ROHS

## SPECIFICATIONS

Rated Current:3.0AMP  
 Contact Resistance:20mΩ Max  
 Withstand Voltage:1000V AC/DC  
 Insulation Resistance:1000MΩ Min  
 Operation Temperature:−40°c to +105°c  
 Contact Material:Brass  
 Contact Plating:Au Over Ni  
 Insulator Material:Polyester(UL94V-0)  
 Standard: PBT  
 Max.Processing Temp: 180°C for 30-60 seconds  
 (200°C for 10 seconds)

Recommended P.C.B Layout(Top Side)  
 (PCB BOARD TOLERANCE±0.05)

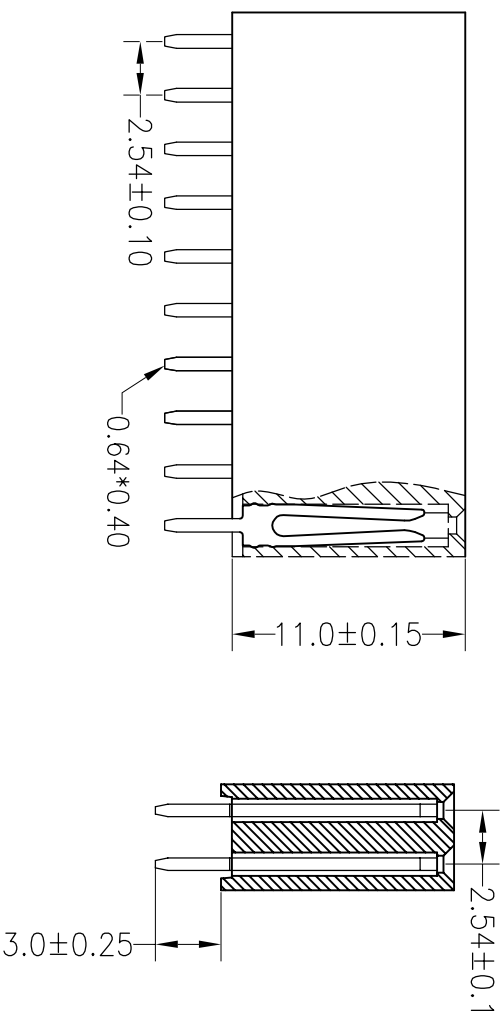
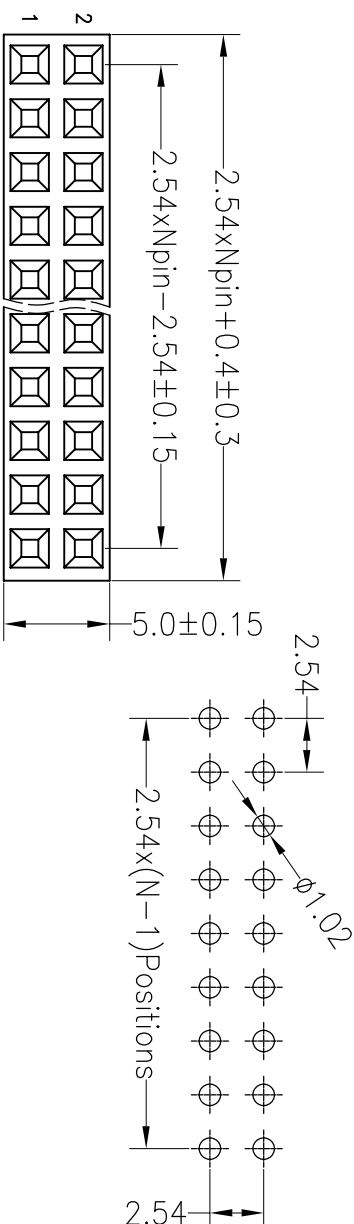

深圳市连盛精密连接器有限公司

PART NO. FH-00285---A0001

TITLE: 2.54FH H11.0mm 2x6pin 180° W5.0mm

REV	DATE	MODIFICATION DESCRIPTION	CHANGE	OPERATION		DRAW		SCALE		FIT	PART NO.
				X.XX	±0.30	CHECK	UNIT	mm	SIZE		
A0	2012.03.28	NEW DRAWING		X.XX	±0.20	CHECK	A4	1/1	1/1		FH-00285---A0001
1				Angle	±3°	APPROVE	PROJ.				