

**IDT  
Manual  
Hand Tool**

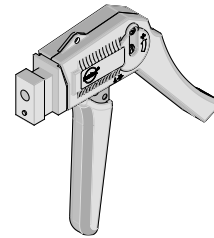

**Application Tooling  
Specification Sheet**



**Order No. 63600-0478**

**FEATURES**

- A full cycle ratcheting hand tool ensures complete crimps
- Use with interchangeable Change Head modules that are easy to install
- This tool is designed for prototype, low volume, and field repair applications

**SCOPE**

This Hand Tool is intended to be used with the Change Head Modules listed below:

Change Head List				
Order No.	Engineering No.	Connector Series No.		Connector Description
11-21-5196	AM60116	7674	7475	KK® IDT Double Cantilever Contact 3.96mm (.156") Pitch, 2 to 16 Circuits. IDT 3.96mm (.156") Pitch, 2 to 24 Circuits
		40791	40915	
11-21-5197	AM60115	7720	7720S	KK® IDT Double Cantilever Contact, 2.54mm (.100") Pitch, 2 to 28 Circuits.
		40555		
11-21-8365	AM60519	7720		KK® IDT Double Cantilever Contact, 2.54mm (.100") Pitch, 2 to 28 Circuits.
		40555		
11-21-9756	AM60512A	70156		5.08mm (.200") Pitch , Female Type IDT Connector
11-31-3337	AM60571	87259	87568	Mill-Grid™ IDT 2.00mm (.079") Pitch Cable-to-Board, 10 to 50 Circuits. MX-50™ 1.27mm (.050") Pitch Slimline Ribbon Cable, 6 to 64 Circuits.
		70625	71247	
		70121	71898	
11-31-3339	AM60539	70121		MX-50™ 1.27mm (.050") Pitch Slimline Ribbon Cable, 6 to 64 Circuits.
11-31-3340	AM60575			Cable Shear
11-31-4652	AM60577	5320	40312	QF-50™ 2.54mm (.100") Pitch Receptacle 10 to 64 Circuits. MX-50™ 1.27mm (.050") Pitch Slimline Ribbon Cable, 6 to 64 Circuits.
		70625	71247	
		71898		
11-31-8939	AM60087	42219	42254	SPOX™ IDT 2.50 mm (.098 inch) Pitch, 2 to 15 Circuits
11-32-5759	AM63186	87259		Mill-Grid™ IDT 2.00mm (.079") Pitch, 10 to 50 Circuits.
11-32-6027	AM63175	71156		5.08mm (.200") Disk Drive Power Connector
11-39-0273	AM63538	30452		IDT 2.00mm (.079") Pitch, 2 to 21 Circuits
11-39-0303	AM63534	71690	71694	Mini-Fit IDT™ 4.20mm (.165") Receptacle and Plug, 2 to 12 Circuits.
62100-0300	62100-0300	70107	71178	SL™ 2.54mm (.100") Pitch Wire-to-Wire Crimp Connector 2 to 25 Circuits.
62100-0400	62100-0400	7674	7675	KK® IDT Double Cantilever Contact. 3.96mm (.156") Pitch, 2 to 16 Circuits. SL™ 2.54mm (.100") Pitch Insulation Displacement, 2 to 25 Circuits.
		70400	70475	
62100-0700	62100-0700	90187		C-Grid III™ 2.54mm (.100") Pitch
62100-2000	62100-2000	87568		Mill-Grid™ IDT 2.00mm (.079") Pitch Cable-to-Board, 10 to 50 Circuits.
69008-0225	69008-0225	7720	7720S	KK® IDT 2.54mm (.100") Double Cantilever Contact, 2 to 28 Circuits
		7795	40555	
69008-0240	69008-0240	7674	7475	KK® IDT Double Cantilever Contact 3.96mm (.156") Pitch, 2 to 16 Circuits
69008-0250	69008-0250	5320	5320	QF 50™ 2.54mm (.100") Pitch, 10-64 Circuits.
		40312	90635	

Change Head List				
Order No.	Engineering No.	Connector Series No.		Connector Description
69008-0270	69008-0270	6952	7933	KK © IDT 5.08mm (.200") Pitch, 2 to 16 Circuits
69008-0290	69008-0290	42219		SPOX™ IDT 2.50 mm (.098 inch) Pitch, 2 to 15 Circuits
		90650	90652	User Friendly IDT 2.50 mm (.098 inch) Pitch Wire-to-Board, 2 to 20 Circuits

## OPERATION

Select the appropriate Change Head and snap it on the front of the hand tool until it engages, refer to the chart.

Refer to the specific Change Head module's Specification Sheet for operating instructions.

## Maintenance

It is recommended that each operator of the tool be made aware of, and responsible for, the following maintenance steps:

1. Remove the plastic handles from the metal tool frame by removing the screws and remove dust, moisture, and other contaminants with a clean brush, or soft, lint free cloth.
2. Do not use any abrasive materials that could damage the tool.
3. Make certain all pins; pivot points and bearing surfaces are protected with a thin coat of high quality machine oil. Do not oil excessively. The tool was engineered for durability but like any equipment it needs cleaning and lubrication for a maximum service life of trouble free crimping. Light oil used at the pivot points every 5,000 crimps or 3 months, will significantly enhance the tool life.
4. Wipe excess oil from hand tool, particularly from crimping area.

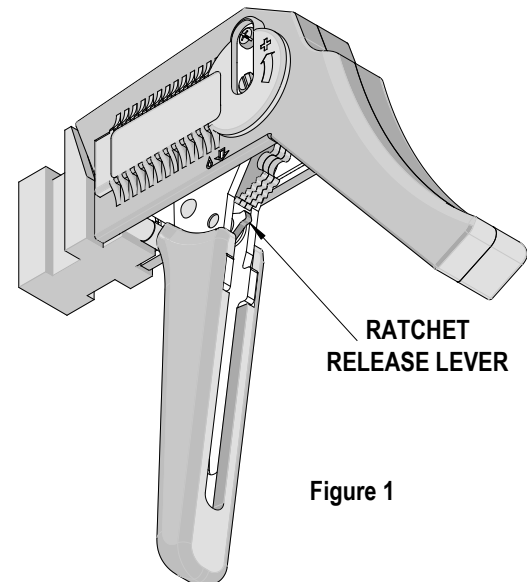

Figure 1

## Miscrimps or Jams

Should this tool ever become stuck or jammed in a partially closed position, **Do Not force the handles open or closed.** The tool will open easily by pressing the ratchet release lever up. See Figure 1.

## How to Adjust Tool Preload

It may be necessary over the life of the tool to adjust tool handle preload force. Listed below are the steps required to adjust the crimping force of the hand tool to obtain proper crimp conditions:

1. Remove the 2mm locking screw from the numbered adjusting wheel using a screw driver. See Figure 2.
2. Using the same screw driver turn the adjustment wheel to the next highest number.  
Note: The odd numbers are in clockwise (CW) direction and the even numbers are counter clockwise (CCW).
3. Example: If the preload is set at number 5, then to increase the preload, turn the adjustment wheel until the 6<sup>th</sup> position is located over the 2mm locking screw tapped hole. If it is necessary to move to the 7<sup>th</sup> position, then the adjustment wheel should be turned clockwise (CW) until the 7<sup>th</sup> position is over the 2mm locking screw tapped hole.
4. Replace the 2mm locking screw, aligning the nearest notch in the setting wheel to locking screw.
5. Check the crimp specifications after the tool handle preload force is adjusted. Repeat these steps until the desired result is obtained.

## Warranty

This tool is for electrical crimping purposes only. This tool is made of the best quality materials. All vital components are long life tested. All tools are warranted to be free of manufacturing defects for a period of 30 days. Should such a defect occur, we will repair or exchange the tool free of charge. This repair or exchange will not be applicable to altered, misused, or damaged tools. This tool is designed for hand use only. Any clamping, fixturing, or use of handle extensions voids this warranty.

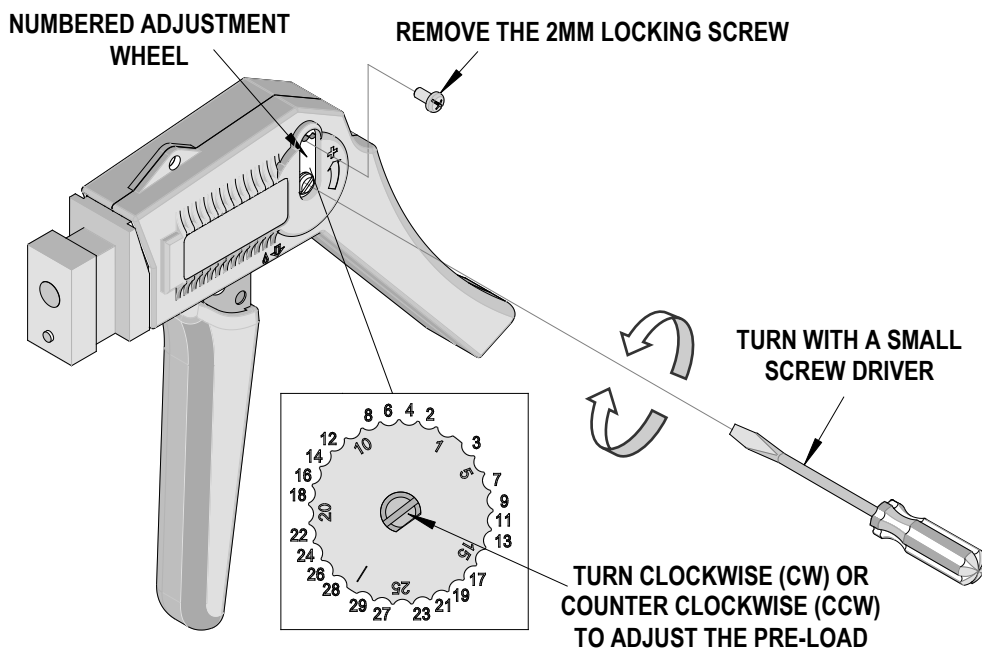

Figure 2

**CAUTION:** Molex crimp specifications are valid only when used with Molex connectors and tooling.

## CAUTIONS:

1. Manually powered hand tools are intended for low volume, prototyping, or field repair. This tool is **NOT** intended for production use. Repetitive use of this tool should be avoided.
2. Insulated rubber handles are not protection against electrical shock.
3. Wear eye protection at all times.
4. Use only the Molex connectors specified for crimping with this tool.

### PARTS LIST

Item Number	Order Number	Description	Quantity
	<b>63600-0478</b>	<b>Hand Crimp Tool</b>	<b>Figure 3</b>
1	11-11-0320	Spring (Ratchet)	1
2	63600-0479	Spring (Main)	1
3	69008-0972	Adjuster Wheel	1

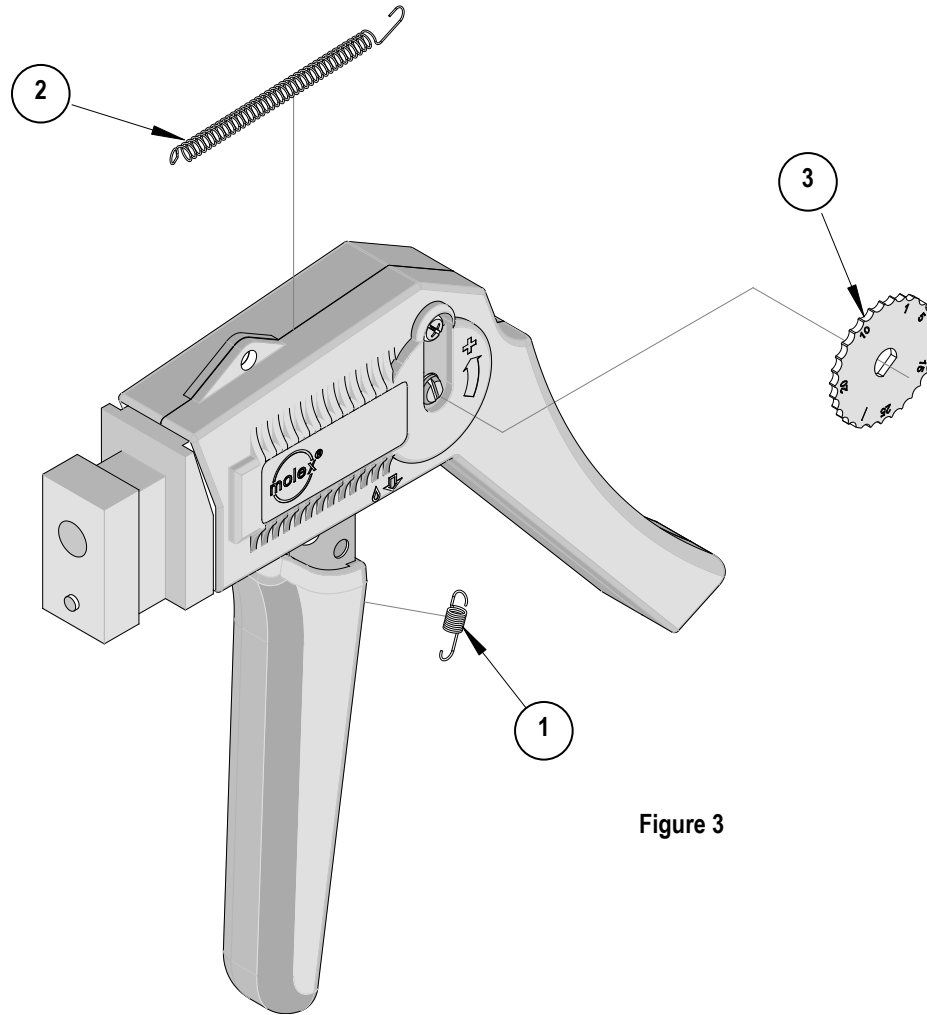

Figure 3

Visit our Web site at <http://www.molex.com>