

SPECIFICATION FOR APPROVAL

1/2W, 0805 Low Resistance Chip Resistor (Lead / Halogen free)

1. Scope

This specification applies to 1.2mm x 2.0mm size 1/2W, fixed metal foil with ceramic carrier current sensing resistors used in electronic equipment.

2. Type Designation

RL1220 — 4 — □□□□ □

(1) (2) (3) (4)

Where

- (1) Series No.
- (2) Power rating
4= 1/2W
- (3) Resistance value:
For example—
R010 = 0.010 Ω
- (4) Resistance tolerance:
F= ± 1%
G= ± 2%
J= ± 5%

3. Construction and Physical Dimensions

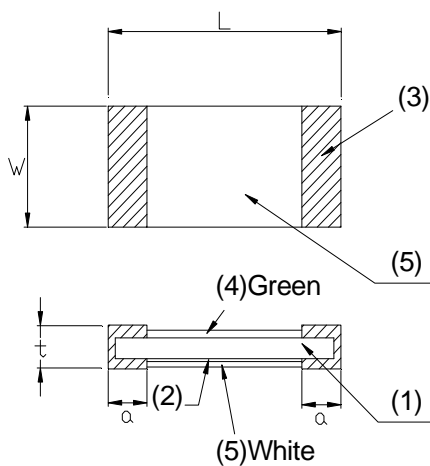

Code Letter	Dimensions (mm)
L	2.00 ± 0.20
W	1.30 ± 0.20
t	0.80 ± 0.25
a	0.40 ± 0.20

NOTE:

- (1) Substrate: Alumina 96%
- (2) Resistor: Cu alloy
- (3) Terminals: Sn (on Cu)
- (4) Marking: Heat resistive epoxy resin(Green)
- (5) Protection coat: Heat resistive epoxy resin(White)

Figure 1. Structure (No mark)

**SPECIFICATION FOR APPROVAL**

4. Ratings

4-1 Specification

Power Rating*	1/2 W
Resistance Range	10~50(mΩ)
Temperature Coefficient of Resistance	±100ppm/°C
Resistance Tolerance	±1% , ±2% , ±5%

Note*:

Power rating is based on continuous full load operation at rated ambient temperature of 70°C. For resistors operated at ambient temperature in excess of 70°C, the maximum load shall be derated in accordance with the following curve.

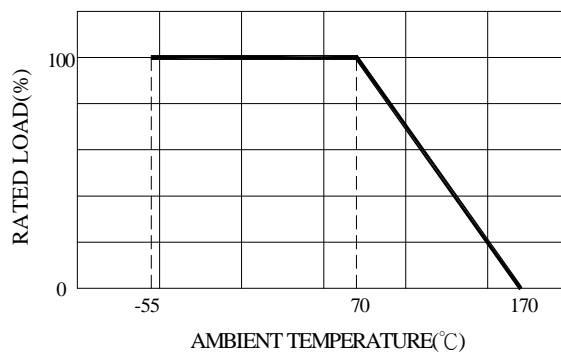

Figure 2. : Power Temperature Derating Curve

4-2 Rated Voltage

The rated voltage shall be determined by the following expression.

$$V = \sqrt{P \times R}$$

Where V : Rated voltage (V)

R : Nominal resistance value (Ω)

P : Rated dissipation (W)

4-3 Operating and Storage Temperature Range

-55 to +170°C



SPECIFICATION FOR APPROVAL

5. Characteristics

Test Item	Condition of Test	Requirements
Short Time Overload	2.5 * Rated power for 5 seconds Refer to JIS C 5201-1 4.13	$\Delta R : \pm (0.5\% + 0.0005\Omega)$ Without significant damage by flashover (spark, arching), burning or breakdown etc.
Insulation Resistance	The resistor shall be cramped in the metal block and tested , as shown below. Test voltage : $100 \pm 15V_{DC}$ for 1 minute Refer to JIS C 5201-1 4.6 Mounting condition G.	Between Electrode and Protection Film $100M\Omega$ or over Between Electrode and Substrate $1,000M\Omega$ or over
Voltage Proof	The voltage : $100V_{AC}$ (rms.) for 1 minute Refer to JIS C 5201-1 4.7	$\Delta R : \pm (0.5\% + 0.0005\Omega)$ Without damage by flashover, fire or breakdown, as shown below.
Thermal Shock	$-55 \sim 125^{\circ}C$ 100 cycles, 15 min at each extreme condition Refer to JIS C 5201-1 4.19	$\Delta R : \pm (1.0\% + 0.0005\Omega)$ Without distinct damage in appearance
Low Temperature Storage	Kept at $-55^{\circ}C$, 1,000 hours Refer to JIS C 5201-1 4.23.4	$\Delta R : \pm (1.0\% + 0.0005\Omega)$ Without distinct damage in appearance
High Temperature Exposure	Kept at $170^{\circ}C$ for 1,000 hours Refer to JIS C 5201-1 4.23.2	$\Delta R : \pm (1.0\% + 0.0005\Omega)$ Without distinct damage in appearance
Solderability	Temperature of Solder : $245 \pm 5^{\circ}C$ Immersion Duration : 2 ± 0.5 second Refer to JIS C 5201-1 4.17	Uniform coating of solder cover minimum of 95% surface being immersed
Resistance to Soldering Heat	Dipped into solder at $270 \pm 5^{\circ}C$ for 10 ± 1 seconds Refer to JIS C 5201-1 4.18	$\Delta R : \pm (0.5\% + 0.0005\Omega)$ Without distinct deformation in appearance

**SPECIFICATION FOR APPROVAL**

Test Item	Condition of Test	Requirements
Load Life	Rated voltage for 1.5 hours followed by a pause 0.5 hour at $70 \pm 2^{\circ}\text{C}$. Cycle repeated 1000 hours Refer to JIS C 5201-1 4.25	$\Delta R : \pm (1.0\% + 0.0005\Omega)$ Without distinct damage in appearance
Damp Heat with Load	$40 \pm 2^{\circ}\text{C}$ with relative humidity 90% to 95%. D.C. rated voltage for 1.5 hours ON and 30 minutes OFF. Cycle repeated 1,000 hours Refer to JIS C 5201-1 4.24	$\Delta R : \pm (1.0\% + 0.0005\Omega)$ Without distinct damage in appearance
Mechanical Shock	100 G's for 6 milliseconds. 5 pulses Refer to JIS C 5201-1 4.21	$\Delta R : \pm (0.5\% + 0.0005\Omega)$ Without mechanical damage such as break
Bending Test	Glass-Epoxy board thickness : 1.6mm Bending width : 2mm Between the fulcrums : 90mm Refer to JIS C 5201-1 4.33	$\Delta R : \pm (0.5\% + 0.0005\Omega)$ Without mechanical damage such as break

SPECIFICATION FOR APPROVAL

6. Recommended Solder Pad Dimensions

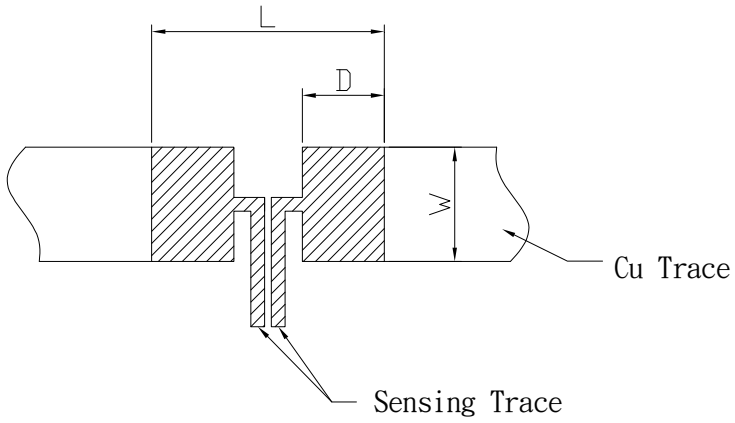

	W (mm)	L (mm)	D (mm)
1220	1.65	3.4	1.2

Note : We recommend there is no circuit design between pads to avoid circuit short

SPECIFICATION FOR APPROVAL

7. Packaging

7-1 Dimensions

7-1-1 Tape packaging dimensions

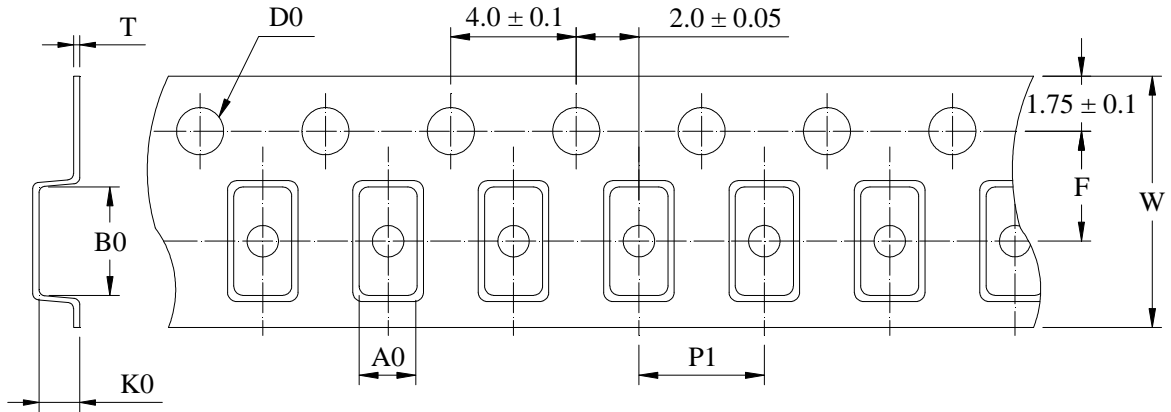

A0	1.65 ± 0.10	F	3.50 ± 0.05
B0	2.35 ± 0.10	P1	4.00 ± 0.10
T	0.20 ± 0.10	W	8.00 ± 0.30
K0	1.05 ± 0.10	D0	φ 1.55 ± 0.05

7-1-2 Reel Dimensions

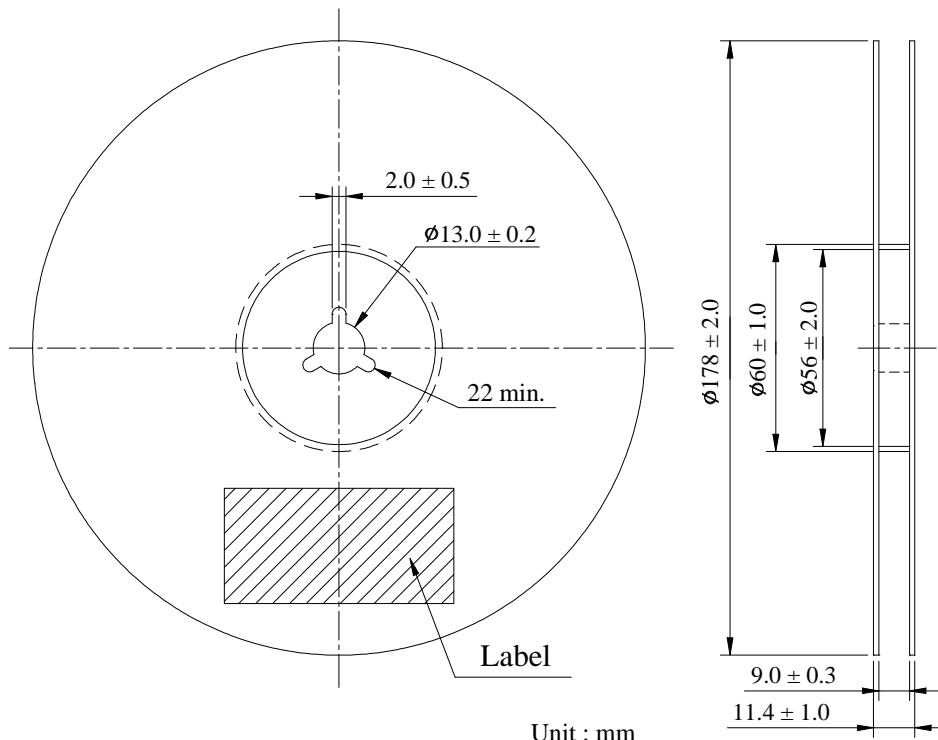

Unit : mm

SPECIFICATION FOR APPROVAL

7-2 Peel force of top cover tape

The peel speed shall be about 300 mm / min.

The peel force of top cover tape shall be between 0.1 to 0.7 N.

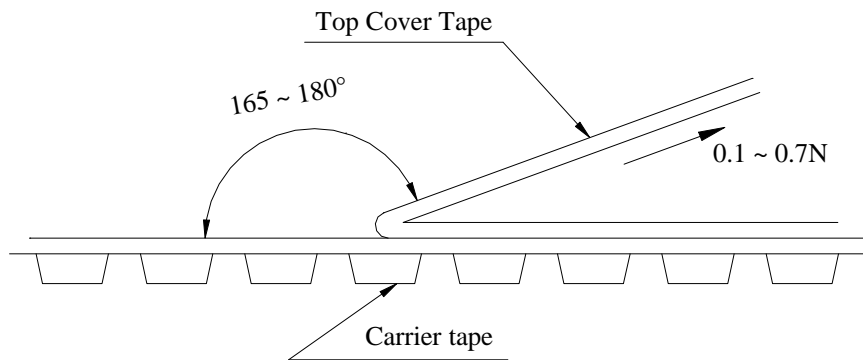

7-3 Numbers of taping

4,000 pieces / reel

7-4 Label marking

The following items shall be marked on the reel.

- (1) Type designation
- (2) Quantity
- (3) Manufacturing date code
- (4) Manufacturer's name
- (5) The country of origin