

MAPX	MODIFICATION	DATE

Specification:

1. Electrical Characteristics:

Dielectric Withstanding Voltage: AC 500V/1MINUTE.
 Insulation Resistance: 1000 MΩMin.
 Contact Resistance: 30 mΩ Max.

2. Mechanical Characteristics:

INSERTION FORCE: 30N(3.06Kgf) MAX
 EXTRACTION FORCE: 10~30N(1.02~3.06Kgf)
 Durability:1500cycles.EXTRACTION FORCE:10~30N(1.02~3.06Kgf)

3. Material:

Terminal: C5191/C2680R-EH T=0.25
 Plating: Gold 0.76 um Min plating over 1.27 um Min Nickel underplate, 2.54 um Min Sn selective plating on solder tail;
 Shell: Bronze, SPCC,H =0.30mm
 Plating: Nickel underplate 2.54 um Min;
 Housing: PBT PA9T LCP Black White

4. Environmental:

Operating Temperature: 0°C to +85°C.

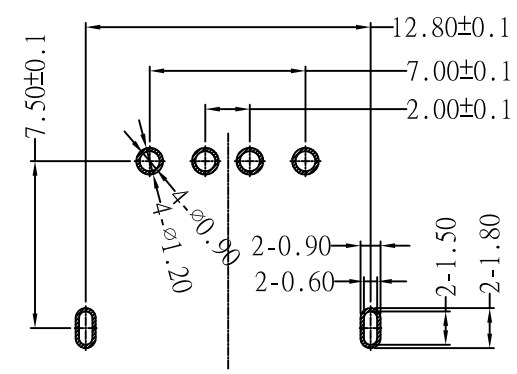
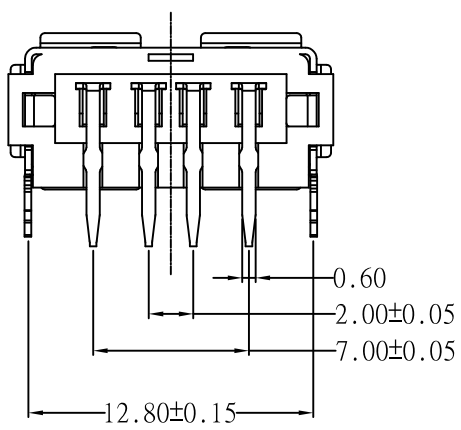
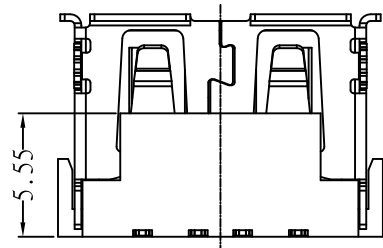
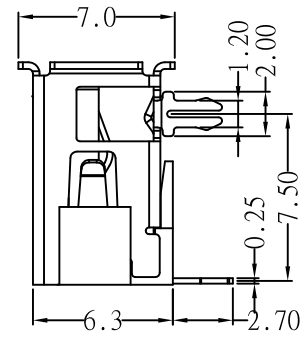
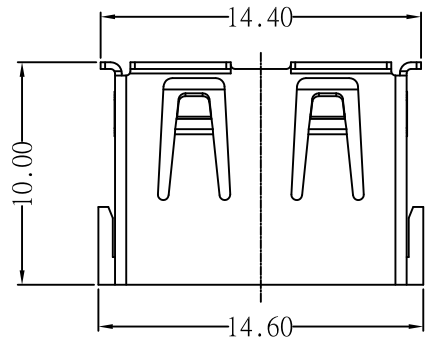
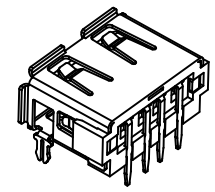
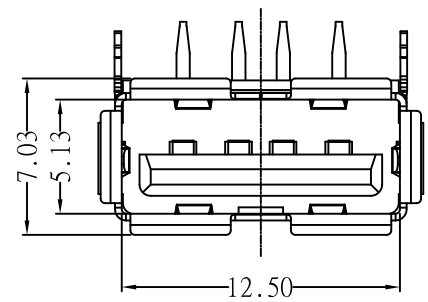

RECOMMENDED P.C.B LAYOUT

产品图 PRODUCT CHART DWG		深圳市精拓金电子有限公司							
公差一览表 TOLERANCE UNLESS OTHERWISE		单位 UNITS	MM	制图 DRAWING	YANG	制图料号 PRODUCT PART NO.	908-171A1011D10100		
X.	±0.30	X.	±5.°	比例 SCALE	1:1	审核 CHKD	郭志富	产品名称 PRODUCT NAME	AF10.0A款前两脚有边有缺口铁壳PBT白胶6.3DIP
.X	±0.25	.X	±2.°	日期 DATE	2019.11.23	核准 APPD	黄国荣	角法 VIEW	版本 VER
.XX	±0.15	.XX	±1.°						AD
.XXX	±0.10	.XXX	±0.5°						