



The Future of Analog IC Technology™

# MP2108

2A, 6V, 720KHz  
Synchronous Buck Converter

INITIAL RELEASE – SPECIFICATIONS SUBJECT TO CHANGE

## DESCRIPTION

The MP2108 is a 2A, 720KHz synchronous buck converter designed for low voltage applications requiring high efficiency. It is capable of providing output voltages as low as 0.9V, and integrates top and bottom switches to minimize power loss and component count. The 720KHz switching frequency allows for small filtering components, further reducing the solution size.

The MP2108 includes cycle-by-cycle current limiting and under voltage lockout. Internal power switches, combined with the tiny 10-pin MSOP or 3mm x 3mm QFN packages, provide a solution requiring a minimum of board space.

## EVALUATION BOARD REFERENCE

| Board Number    | Dimensions            |
|-----------------|-----------------------|
| EV2108DQ/DK-00A | 2.5"X x 2.0"Y x 0.5"Z |

## FEATURES

- 2A Output Current
- Synchronous Rectification
- Internal 160mΩ and 190mΩ Power Switches
- Input Range of 2.6V to 6V
- Over 90% Efficiency
- Zero Current Shutdown Mode
- Under Voltage Lockout Protection
- Soft-Start Operation
- Thermal Shutdown
- Internal Current Limit (Source & Sink)
- Tiny 10-Pin MSOP and 3x3 QFN Packages

## APPLICATIONS

- SOHO Routers, PCMCIA Cards, Mini PCI
- Handheld Computers, PDAs
- Cell phones, Digital Still and Video Cameras
- Small LCD Displays

"MPS" and "The Future of Analog IC Technology" are Trademarks of Monolithic Power Systems, Inc.

## TYPICAL APPLICATION

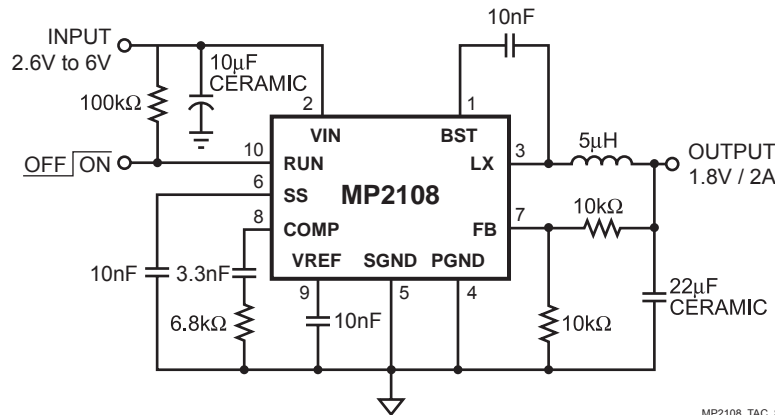

MP2108\_TAC\_S01

## PACKAGE REFERENCE

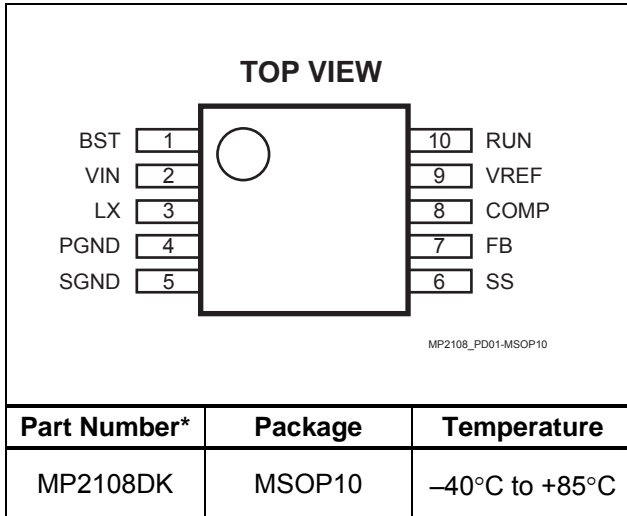

\* For Tape & Reel, add suffix -Z (eg. MP2108DK-Z)  
For Lead Free, add suffix -LF (eg. MP2108DK-LF-Z)

### ABSOLUTE MAXIMUM RATINGS <sup>(1)</sup>

Input Supply Voltage  $V_{IN}$  ..... 6.5V  
 LX Voltage  $V_{LX}$  ..... -0.3V to  $V_{IN} + 0.3V$   
 BST to LX Voltage ..... -0.3V to +6V  
 Voltage on All Other Pins ..... -0.3V to +6V  
 Storage Temperature ..... -55°C to +150°C

### Recommended Operating Conditions <sup>(2)</sup>

Input Supply Voltage  $V_{IN}$  ..... 2.6V to 6  
 Output Voltage  $V_{OUT}$  ..... 0.9V to 5V  
 Operating Temperature ..... -40°C to +85°C

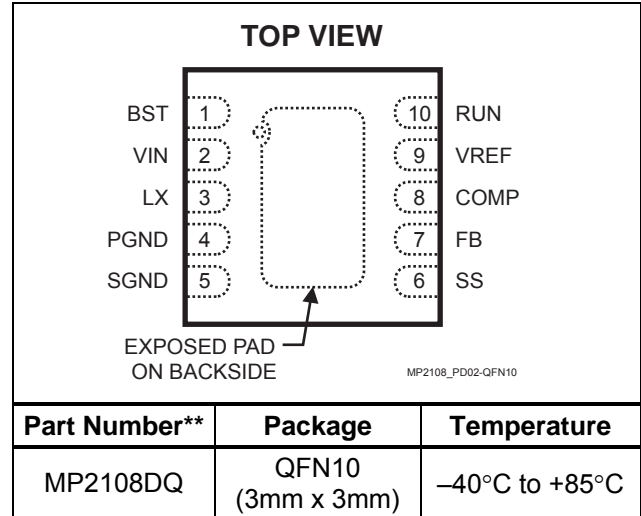

\*\* For Tape & Reel, add suffix -Z (eg. MP2108DQ-Z)  
For Lead Free, add suffix -LF (eg. MP2108DQ-LF-Z)

**Thermal Resistance <sup>(3)</sup>**      $\theta_{JA}$       $\theta_{JC}$   
 MSOP10 ..... 150 ..... 65... °C/W  
 QFN10 (3mm x 3mm) ..... 50 ..... 12... °C/W

#### Notes:

- 1) Exceeding these ratings may damage the device.
- 2) The device is not guaranteed to function outside of its operating conditions.
- 3) Measured on approximately 1" square of 1 oz copper.

## ELECTRICAL CHARACTERISTICS

$V_{IN} = 5.0V$ ,  $T_A = +25^\circ C$ , unless otherwise noted.

| Parameter                             | Symbol    | Condition                        | Min | Typ | Max | Units   |
|---------------------------------------|-----------|----------------------------------|-----|-----|-----|---------|
| Input Voltage Range                   | $V_{IN}$  |                                  | 2.6 |     | 6   | V       |
| Input Undervoltage Lockout            |           |                                  |     | 2.2 |     | V       |
| Input Undervoltage Lockout Hysteresis |           |                                  |     | 100 |     | mV      |
| Shutdown Supply Current               |           | $V_{RUN} \leq 0.3V$              |     | 0.5 | 1.0 | $\mu A$ |
| Operating Supply Current              |           | $V_{RUN} > 2V$ , $V_{FB} = 1.1V$ |     | 1.2 | 1.8 | mA      |
| VREF Voltage                          | $V_{REF}$ | $V_{IN} = 2.6V$ to 6V            |     | 2.4 |     | V       |
| RUN Input Low Voltage                 | $V_{IL}$  |                                  |     |     | 0.4 | V       |
| RUN Input High Voltage                | $V_{HL}$  |                                  | 1.5 |     |     | V       |
| RUN Hysteresis                        |           |                                  |     | 100 |     | mV      |
| RUN Input Bias Current                |           |                                  |     |     | 1   | $\mu A$ |

**ELECTRICAL CHARACTERISTICS (continued)**
 $V_{IN} = 5.0V$ ,  $T_A = +25^{\circ}C$ , unless otherwise noted.

| Parameter                                  | Symbol    | Condition       | Min | Typ      | Max | Units       |
|--|-----------|-----------------|-----|----------|-----|-------------|
| <b>Oscillator</b>                          |           |                 |     |          |     |             |
| Switching Frequency                        | $f_{SW}$  |                 | 620 | 720      | 920 | KHz         |
| Maximum Duty Cycle                         | $D_{MAX}$ | $V_{FB} = 0.7V$ | 85  |          |     | %           |
| Minimum On Time                            | $T_{ON}$  |                 |     | 200      |     | ns          |
| <b>Error Amplifier</b>                     |           |                 |     |          |     |             |
| Voltage Gain                               | $A_{VEA}$ |                 |     | 400      |     | V/V         |
| Transconductance                           | $G_{EA}$  |                 |     | 300      |     | $\mu A/V$   |
| COMP Maximum Output Current                |           |                 |     | $\pm 30$ |     | $\mu A$     |
| FB Regulation Voltage                      | $V_{FB}$  |                 | 880 | 900      | 920 | mV          |
| FB Input Bias Current                      | $I_{FB}$  | $V_{FB} = 0.9V$ |     | -100     |     | nA          |
| <b>Soft-Start</b>                          |           |                 |     |          |     |             |
| Soft-Start Current                         | $I_{SS}$  |                 |     | 2        |     | $\mu A$     |
| <b>Output Switch On-Resistance</b>         |           |                 |     |          |     |             |
| Switch On Resistance                       |           | $V_{IN} = 5V$   |     | 190      |     | m $\Omega$  |
|  |           | $V_{IN} = 3V$   |     | 280      |     | m $\Omega$  |
| Synchronous Rectifier On Resistance        |           | $V_{IN} = 5V$   |     | 160      |     | m $\Omega$  |
|  |           | $V_{IN} = 3V$   |     | 230      |     | m $\Omega$  |
| Switch Current Limit (Source)              |           |                 | 2.5 | 3.5      |     | A           |
| Synchronous Rectifier Current Limit (Sink) |           |                 |     | 350      |     | mA          |
| Thermal Shutdown                           |           |                 |     | 160      |     | $^{\circ}C$ |

**PIN FUNCTIONS**

| Pin # | Name | Description  |
|-------|------|--|
| 1     | BST  | Power Switch Boost. BST powers the gate of the high-side N-Channel power MOSFET switch. Connect a 10nF or greater capacitor between BST and LX.  |
| 2     | VIN  | Internal Power Input. VIN supplies the power to the MP2108 through the internal LDO regulator. Bypass VIN to PGND with a 10 $\mu$ F or greater capacitor. Connect VIN to the input source voltage.   |
| 3     | LX   | Output Switching Node. LX is the source of the high-side N-Channel switch and the drain of the low-side N-Channel switch. Connect the output LC filter between LX and the output.  |
| 4     | PGND | Power Ground. PGND is the source of the N-Channel MOSFET synchronous rectifier. Connect PGND to SGND as close to the MP2108 as possible.   |
| 5     | SGND | Signal Ground.   |
| 6     | SS   | Soft-Start Input. Place a capacitor from SS to SGND to set the soft-start period. The MP2108 sources 2 $\mu$ A from SS to the soft-start capacitor at start up. As the voltage at SS rises, the feedback threshold voltage increases to limit inrush current at startup. |
| 7     | FB   | Feedback Input. FB is the inverting input of the internal error amplifier. Connect a resistive voltage divider from the output voltage to FB to set the output voltage.  |
| 8     | COMP | Compensation Node. COMP is the output of the error amplifier. Connect a series RC network to compensate the regulation control loop.   |
| 9     | VREF | Internal 2.4V Regulator Bypass. Connect a 10nF capacitor between VREF and SGND to bypass the internal regulator. Do not apply any load to VREF.  |
| 10    | RUN  | On/Off Control Input. Drive RUN high to turn on the MP2108, drive RUN low to turn the MP2108 off. For automatic startup, connect RUN to VIN via a pullup resistor.   |

**OPERATION**

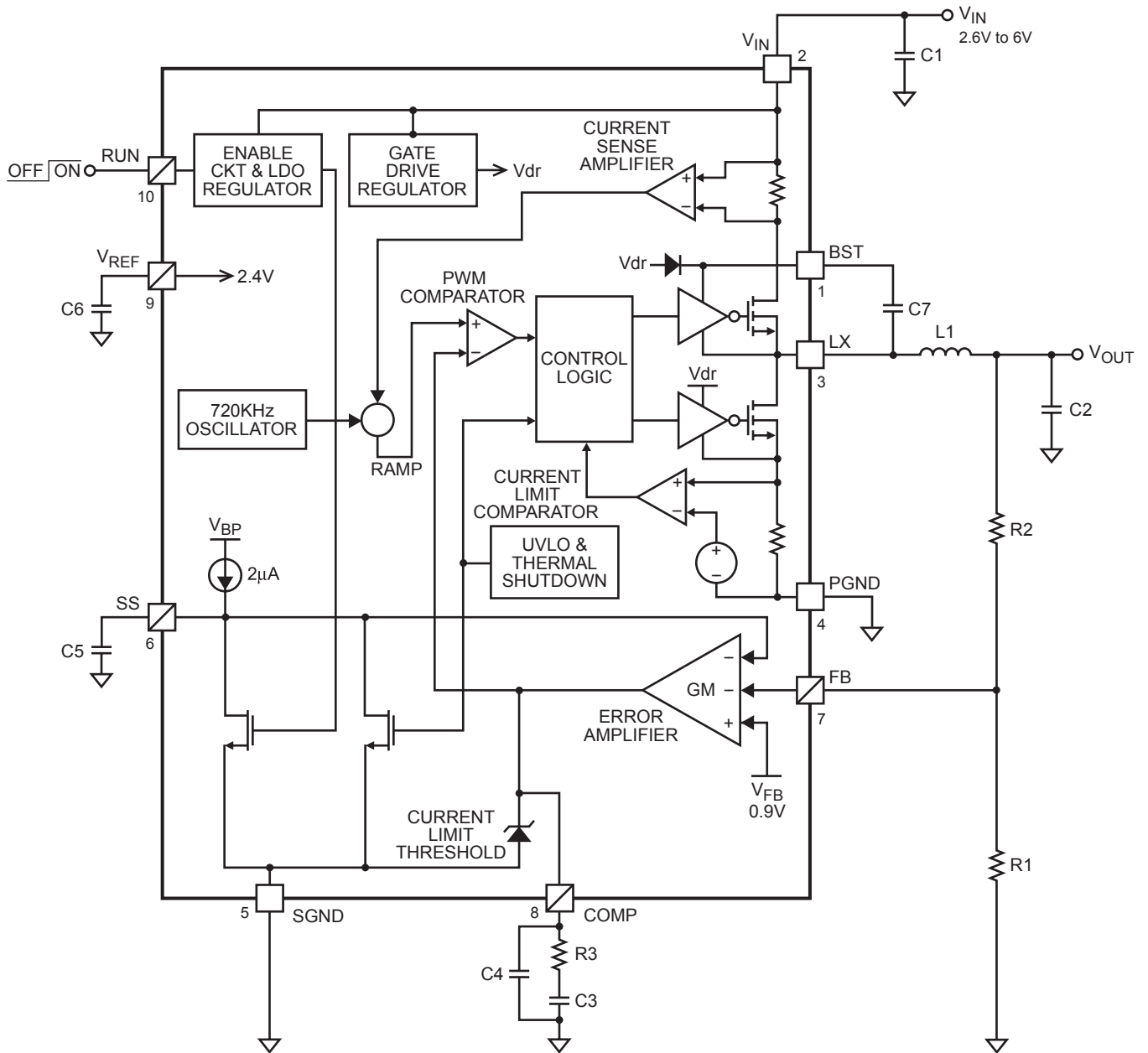

MP2108\_BD01

**Figure 1—Functional Block Diagram**

The MP2108 measures the output voltage through an external resistive voltage divider and compares it to the internal 0.9V reference to generate the error voltage at COMP. The current-mode regulator uses the voltage at COMP and compares it to the inductor current to regulate the output voltage. The use of current-mode regulation improves transient response and control loop stability.

At the beginning of each cycle, the high-side N-Channel MOSFET is turned on, forcing the inductor current to rise. The current at the drain of the high-side MOSFET is internally measured and converted to a voltage by the current sense amplifier.

That voltage is compared to the error voltage at COMP. When the inductor current rises sufficiently, the PWM comparator turns off the high-side switch and turns on the low-side switch, forcing the inductor current to decrease.

The average inductor current is controlled by the voltage at COMP, which in turn, is controlled by the output voltage. Thus the output voltage controls the inductor current to satisfy the load.

Since the high-side N-Channel MOSFET requires voltage above  $V_{IN}$  to drive its gate, a bootstrap capacitor from LX to BST is required to drive the high-side MOSFET gate. When LX is driven low (through the low-side MOSFET), the BST capacitor is internally charged. The voltage at BST is applied to the high-side MOSFET gate to turn it on. Voltage is maintained until the high-side MOSFET is turned off and the low-side MOSFET is turned on, and the cycle repeats. Connect a 10nF or greater capacitor from BST to SW to drive the high-side MOSFET gate.

## APPLICATION INFORMATION

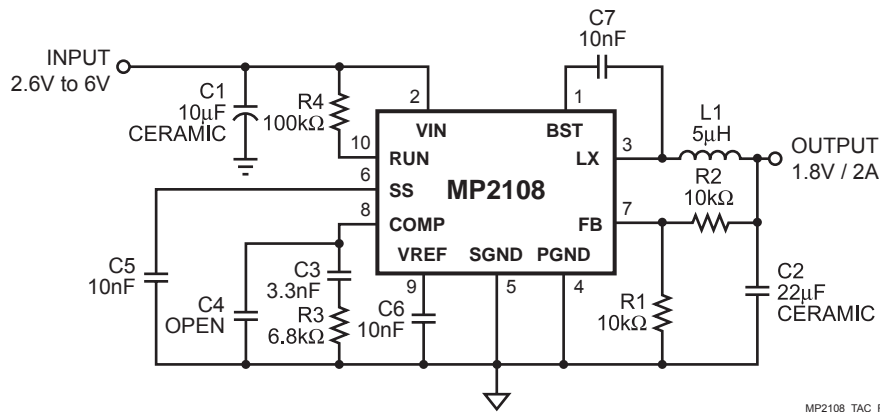

**Figure 2—Typical Application Circuit**

### Internal Low-Dropout Regulator

The internal power to the MP2108 is supplied from the input voltage ( $V_{IN}$ ) through an internal 2.4V low-dropout linear regulator, whose output is  $V_{REF}$ . Bypass  $V_{REF}$  to  $SGND$  with a 10nF or greater capacitor for proper operation. The internal regulator can not supply more current than is required to operate the MP2108. Therefore, do not apply any external load to  $V_{REF}$ .

### Soft-Start

The MP2108 includes a soft-start timer that slowly ramps the output voltage at startup to prevent excessive current at the input.

When power is applied to the MP2108, and  $RUN$  is asserted, a 2µA internal current source charges the external capacitor at  $SS$ . As the capacitor charges, the voltage at  $SS$  rises. The MP2108 internally limits the feedback threshold voltage at  $FB$  to that of the voltage at  $SS$ . This forces the output voltage to rise at the same

rate as the voltage at SS, forcing a linear output voltage ramp from 0V to the desired regulation voltage during soft-start.

The soft-start period is determined by the equation:

$$t_{SS} = 0.45 \times C5$$

Where C5 (in nF) is the soft-start capacitor from SS to GND, and  $t_{SS}$  (in ms) is the soft-start period. Determine the capacitor required for a given soft-start period by the equation:

$$C5 = 2.22 \times t_{SS}$$

Use values for C5 between 10nF and 22nF to set the soft-start period (between 4ms and 10ms).

### Setting the Output Voltage (see Figure 2)

Set the output voltage by selecting the resistive voltage divider ratio. The voltage divider drops the output voltage to the 0.9V feedback voltage. Use 10kΩ for the low-side resistor of the voltage divider. Determine the high-side resistor by the equation:

$$R2 = \left( \frac{V_{OUT}}{0.9V} - 1 \right) \times R1$$

Where R2 is the high-side resistor,  $V_{OUT}$  is the output voltage and R1 is the low-side resistor and  $V_{OUT}$  is the output voltage.

### Selecting the Input Capacitor

The input current to the step-down converter is discontinuous, so a capacitor is required to supply the AC current to the step-down converter while maintaining the DC input voltage. A low ESR capacitor is required to keep the noise at the IC to a minimum. Ceramic capacitors are preferred, but tantalum or low ESR electrolytic capacitors are also an option..

The capacitor can be electrolytic, tantalum or ceramic. Because it absorbs the input switching current it must have an adequate ripple current rating. Use a capacitor with RMS current rating greater than 1/2 of the DC load current.

For stable operation, place the input capacitor as close to the IC as possible. A smaller high quality 0.1μF ceramic capacitor may be placed closer to the IC with the larger capacitor placed further away.

If using this technique, it is recommended that the larger capacitor be a tantalum or electrolytic type. All ceramic capacitors should be placed close to the MP2108. For most applications, a 10μF ceramic capacitor will work.

### Selecting the Output Capacitor

The output capacitor (C2) is required to maintain the DC output voltage. Low ESR capacitors are preferred to keep the output voltage ripple to a minimum. The characteristics of the output capacitor also affect the stability of the regulation control system. Ceramic, tantalum, or low ESR electrolytic capacitors are recommended.

The output voltage ripple is:

$$V_{RIPPLE} = \frac{V_{OUT}}{f_{SW} \times L} \times \left( 1 - \frac{V_{OUT}}{V_{IN}} \right) \times \left( R_{ESR} + \frac{1}{8 \times f_{SW} \times C2} \right)$$

Where  $V_{RIPPLE}$  is the output voltage ripple,  $f_{SW}$  is the switching frequency,  $V_{IN}$  is the input voltage and  $R_{ESR}$  is the equivalent series resistance of the output capacitors.

Choose an output capacitor to satisfy the output ripple requirements of the design. A 22μF ceramic capacitor is suitable for most applications.

### Selecting the Inductor

The inductor is required to supply constant current to the output load while being driven by the switched input voltage. A larger value inductor results in less ripple current that in turn results in lower output ripple voltage. However, the larger value inductor is likely to have a larger physical size and higher series resistance. Choose an inductor that does not saturate under the worst-case load conditions. A good rule for determining the inductance is to allow peak-to-peak ripple current to be approximately 30% to 40% of the maximum load current. Make sure that the peak inductor current (the load current plus half the peak-to-peak inductor ripple current) is below 2.5A to prevent loss of regulation due to the current limit.

Calculate the required inductance value by the equation:

$$L = \frac{V_{OUT} \times (V_{IN} - V_{OUT})}{V_{IN} \times f_{SW} \times \Delta I}$$

Where  $\Delta I$  is the peak-to-peak inductor ripple current. It is recommended to choose  $\Delta I$  to be 30%~40% of the maximum load current.

### Compensation

The system stability is controlled through the COMP pin. COMP is the output of the internal transconductance error amplifier. A series capacitor-resistor combination sets a pole-zero combination to control the characteristics of the control system.

The DC loop gain is:

$$A_{VDC} = \left( \frac{V_{FB}}{V_{OUT}} \right) \times A_{VEA} \times G_{CS} \times R_{LOAD}$$

Where  $V_{FB}$  is the feedback voltage, 0.9V,  $A_{VEA}$  is the transconductance error amplifier voltage gain, 400 V/V and  $G_{CS}$  is the current sense transconductance, (roughly the output current divided by the voltage at COMP), 4.5A/V.

$R_{LOAD}$  is the load resistance:

$$R_{LOAD} = \frac{V_{OUT}}{I_{OUT}}$$

Where  $I_{OUT}$  is the output load current.

The system has 2 poles of importance, one is due to the compensation capacitor (C3), and the other is due to the load resistance and the output capacitor (C2), where:

$$f_{P1} = \frac{G_{EA}}{2\pi \times A_{VEA} \times C3}$$

P1 is the first pole, and  $G_{EA}$  is the error amplifier transconductance (300 $\mu$ A/V) and

$$f_{P2} = \frac{1}{2\pi \times R_{LOAD} \times C2}$$

The system has one zero of importance, due to the compensation capacitor (C3) and the compensation resistor (R3). The zero is:

$$f_{Z1} = \frac{1}{2\pi \times R3 \times C3}$$

If large value capacitors with relatively high equivalent-series-resistance (ESR) are used, the zero due to the capacitance and ESR of the output capacitor can be compensated by a third pole set by R3 and C4. The pole is:

$$f_{P3} = \frac{1}{2\pi \times R3 \times C4}$$

The system crossover frequency (the frequency where the loop gain drops to 1dB or 0dB) is important. Set the crossover frequency below one tenth of the switching frequency to insure stable operation. Lower crossover frequencies result in slower response and worse transient load recovery. Higher crossover frequencies degrade the phase and/or gain margins and can result in instability.

**Table 1—Compensation Values for Typical Output Voltage/Capacitor Combinations**

| V <sub>OUT</sub> | C2                                   | R3            | C3    | C4    |
|------------------|--------------------------------------|---------------|-------|-------|
| 1.8V             | 22 $\mu$ F Ceramic                   | 6.8k $\Omega$ | 3.3nF | None  |
| 2.5V             | 22 $\mu$ F Ceramic                   | 9.1k $\Omega$ | 2.2nF | None  |
| 3.3V             | 22 $\mu$ F Ceramic                   | 12k $\Omega$  | 1.8nF | None  |
| 1.8V             | 47 $\mu$ F Tantalum (300m $\Omega$ ) | 13k $\Omega$  | 2nF   | 1nF   |
| 2.5V             | 47 $\mu$ F Tantalum (300m $\Omega$ ) | 18k $\Omega$  | 1.2nF | 750pF |
| 3.3V             | 47 $\mu$ F Tantalum (300m $\Omega$ ) | 24k $\Omega$  | 1nF   | 560pF |

### Choosing the Compensation Components

The values of the compensation components given in Table 1 yields a stable control loop for the output voltage and capacitor given. To optimize the compensation components for conditions not listed in Table 1, use the following procedure.

Choose the compensation resistor to set the desired crossover frequency. Determine the value by the following equation:

$$R3 = \frac{2\pi \times C2 \times f_C}{G_{EA} \times G_{CS}} \times \frac{V_{OUT}}{V_{FB}}$$

Where  $G_{EA}$  is the EA transconductance (300 $\mu$ A/V), and  $f_C$  is the desired crossover frequency (preferably 33KHz).

Choose the compensation capacitor to set the zero below one fourth of the crossover frequency. Determine the value by the following equation:

$$C3 > \frac{2}{\pi \times R3 \times f_C}$$

Determine if the second compensation capacitor, C4 is required. It is required if the ESR zero of the output capacitor happens at less than half of the switching frequency. Or:

$$\pi \times C2 \times R_{ESR} \times f_{SW} > 1$$

where  $R_{ESR}$  is the equivalent series resistance of the output capacitor.

If this is the case, then add the second compensation capacitor.

Determine the value by the equation:

$$C4 = \frac{C2 \times R_{ESR(max)}}{R3}$$

Where  $R_{ESR(MAX)}$  is the maximum ESR of the output capacitor.

### External Boost Diode

It is recommended that an external boost diode be added to help improve the regulator efficiency. The diode can be a low cost diode such as an IN4148 or BAT54.

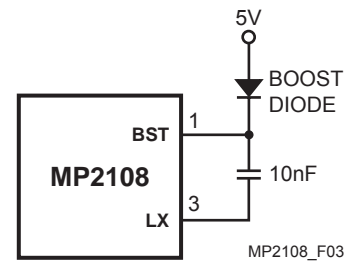
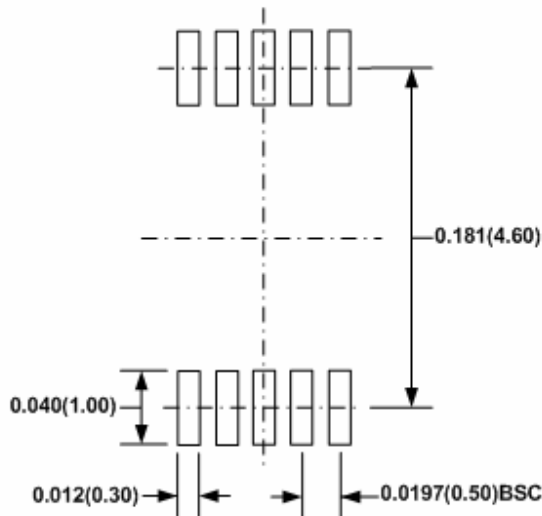
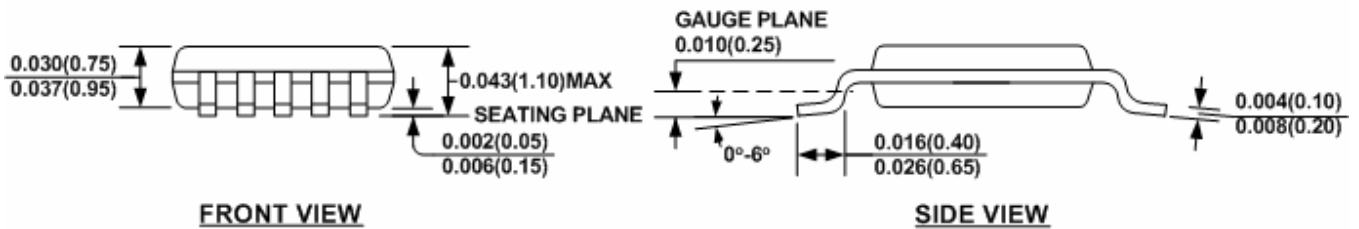
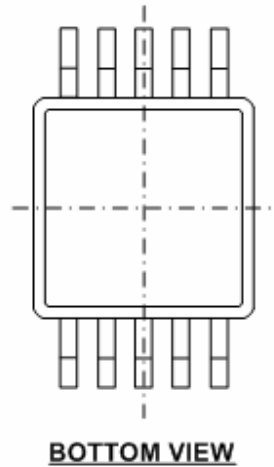
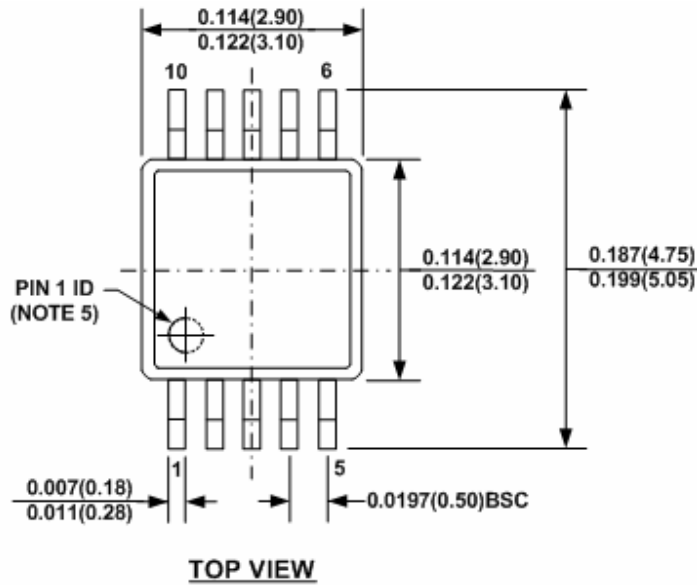

**Figure 3—External Boost Diode**

This diode is also recommended for high duty cycle operation (when  $\frac{V_{OUT}}{V_{IN}} > 65\%$ ).

PACKAGE INFORMATION

MSOP10



NOTE:

- 1) CONTROL DIMENSION IS IN INCHES. DIMENSION IN BRACKET IS IN MILLIMETERS.
- 2) PACKAGE LENGTH DOES NOT INCLUDE MOLD FLASH, PROTRUSION OR GATE BURR.
- 3) PACKAGE WIDTH DOES NOT INCLUDE INTERLEAD FLASH OR PROTRUSION.
- 4) LEAD COPLANARITY (BOTTOM OF LEADS AFTER FORMING) SHALL BE 0.004" INCHES MAX.
- 5) PIN 1 IDENTIFICATION HAS THE HALF OR FULL CIRCLE OPTION.
- 6) DRAWING MEETS JEDEC MO-817, VARIATION BA.
- 7) DRAWING IS NOT TO SCALE.

QFN10 (3mm x 3mm)

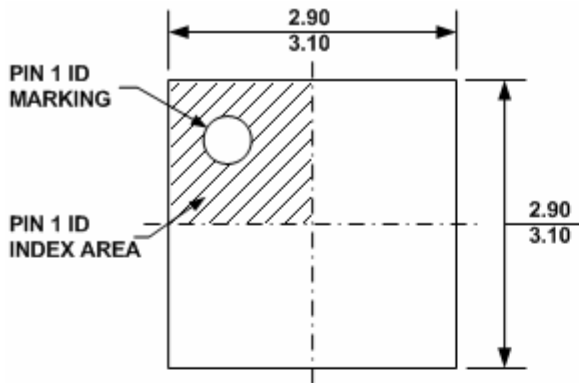

TOP VIEW

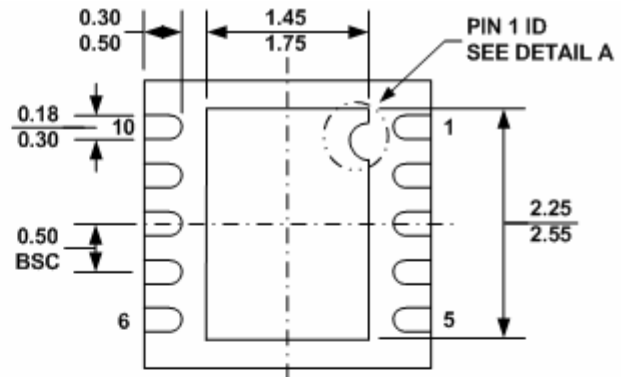

BOTTOM VIEW

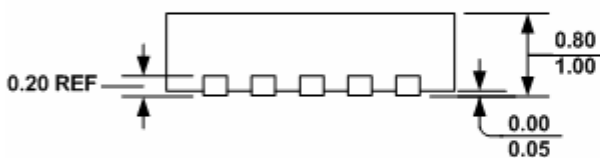

SIDE VIEW

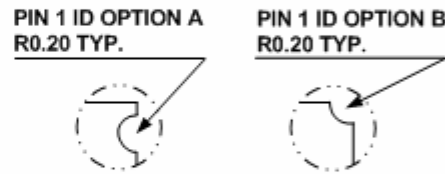

DETAIL A

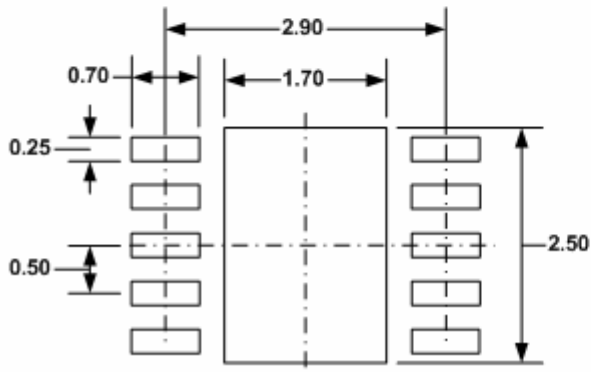

RECOMMENDED LAND PATTERN

**NOTE:**

- 1) ALL DIMENSIONS ARE IN MILLIMETERS.
- 2) EXPOSED PADDLE SIZE DOES NOT INCLUDE MOLD FLASH.
- 3) LEAD COPLANARITY SHALL BE 0.10 MILLIMETER MAX.
- 4) DRAWING CONFORMS TO JEDEC MO-229, VARIATION VEED-5.
- 5) DRAWING IS NOT TO SCALE.

**NOTICE:** The information in this document is subject to change without notice. Please contact MPS for current specifications. Users should warrant and guarantee that third party Intellectual Property rights are not infringed upon when integrating MPS products into any application. MPS will not assume any legal responsibility for any said applications.