



BROADCAST

CATALOGUE

Broadcast Solutions

Professional Antennas and Combiners



KATHREIN

Information about KATHREIN Broadcast

As of 1st June 2019, KATHREIN SE's (formerly KATHREIN-Werke KG) business unit "BROADCAST" will be transferred to KATHREIN Broadcast GmbH (limited liability company).

From 1st June 2019, the new company data are:

KATHREIN Broadcast GmbH

Ing.-Anton-Kathrein-Str. 1, 3, 5, 7

83101 Rohrdorf, Germany

Tax Payer's ID No.: 156/117/31113

VAT Reg. No.: DE 323 189 785

Commercial Register Traunstein: HRB 27745

Kathrein Broadcast Antenna Systems are known for their well-thought-out engineering, and solutions which are exactly tailored to the customer specifications. The products are of the highest quality, designed for long-term trouble free operation, even in harsh environmental conditions. Radiators and reflectors are made of hot-dip galvanized steel or corrosion-resistant aluminum alloy. The selected materials provide a long product life combined with best RF broadband performance.

Photo on title page: Kathrein Smart Monitoring System

Catalogue Issue 06/2019



Our quality assurance system and our environmental management system apply to the entire company and are certified by TÜV according to EN ISO 9001 and EN ISO 14001.



Our products are compliant to the EU Directive RoHS as well as to other environmentally relevant regulations (e.g. REACH).

Kathrein is one of the world's leading manufacturers of professional broadcast antenna systems, including a full range of transmitting antennas for FM, TV, DAB and DTV broadcasting.

Kathrein was founded in 1919 in Rosenheim, Germany, to produce antennas and lightning protection equipment.

Since 1955 Kathrein has been supplying professional antenna systems of all sizes to broadcasters in every part of the world, from Canada to China and from Norway to South Africa.

Right from the start Kathrein has maintained a high level of engineering capability. Today there is a team of antenna and mechanical engineers dealing exclusively with broadcast transmitting antennas.

This highly qualified engineering team is responsible for:

- Design of components (antennas, power splitters, etc.).
- Design and optimization of complete antenna systems.
- Installation and testing of antenna systems.
- Project management.

Kathrein can provide turn-key installations in cooperation with other contractors or using the customer's installation personnel.

Customers are welcome to take advantage of the technical expertise available from Kathrein and to discuss their specific requirements. If your needs cannot be met with our standard components we are prepared to develop special solutions for you.

Kathrein's quality management system is certified in accordance with ISO 9001, which includes not only all manufacturing operations, but also design processes.

Please note

As a result of more stringent legal regulations and judgements regarding product liability, we are obliged to point out certain risks that may arise when products are used under extraordinary operating conditions.

The mechanical design is based on the environmental conditions as stipulated in ETS 300 019-1-4.

The antennas may be used at locations where the anticipated peak wind velocity or gust wind speed lies within the maximum wind speed listed in the datasheet. We guarantee the mechanical safety and electrical functionality under such conditions. The wind speeds are defined in accordance with the DIN, EN or TIA standards. This guarantee makes allowance for the partial safety factors specified in those standards.

Extraordinary operating conditions, such as heavy icing or exceptional dynamic stress (e.g. strain caused by oscillating support structures), may result in the breakage of an antenna or even cause it to fall to the ground. Cylindrical bodies can show crosswind response, which can cause the supporting structure to oscillate and to be damaged. Prismatic bodies, even with non-circular cross-section can show crosswind response, which can cause the supporting structure to oscillate (see EN 1991-1-4 or EN 1993-3-1).

These facts must be considered during the site planning process.

The installation team must be properly qualified and also be familiar with the relevant national safety regulations.

The details given in our data sheets have to be followed carefully when installing the antennas and accessories.

The limits for the coupling torque of RF-connectors, recommended by the connector manufacturers must be obeyed.

Our quality assurance system and our environmental management system apply to the entire company and are certified by TÜV according to EN ISO 9001 and EN ISO 14001.

We reserve the right to make alterations in accordance with the requirements of our customers, therefore for binding data please check valid data sheets on our homepage: www.kathrein.com

Antenna Systems

The antenna systems listed are examples of typical configurations.

The mechanical and electrical data can be used to estimate gain, size and mechanical loads of a system.

The final configuration and technical data of an individually designed antenna system, meeting the customer's specific needs, will be determined by the Kathrein engineers.

Antennas, Power Splitters and Accessories

The basic antennas and related components shown in this catalog are only a small portion of the Kathrein broadcast product line.

Various power splitters with different splitting ratio are available to create customized radiation patterns.

Your enquiries are most welcome and we would like to discuss your special requirements.

> **Band I (VHF) Antenna Systems** 47...88 MHz

> **Band I (VHF) Antennas** 47...88 MHz

> **Band II (FM) Antenna Systems** 87.5–108 MHz

> **Band II (FM) Antennas** 87.5–108 MHz

> **Band III (VHF) Antenna Systems** 174–240 MHz

> **Band III (VHF) Antennas** 174–240 MHz

> **Band IV/V (UHF) Antenna Systems** 470–862 MHz

> **Band IV/V (UHF) Antennas** 470–862 MHz

> **Power Splitters**

> **Combiners and Filters for FM Broadcast**

> **Further Components**

> **Technical Annex**

Summary of Types

KATHREIN

The articles are listed by order number in numerical order.

Order No.	Page	Order No.	Page	Order No.	Page	Order No.	Page	Order No.	Page
092...		601...		715...		75010033	70	75010292	74
0921100	132	601070	18	715849	40	75010066	100	75010295	75
0921262	132	601071	18			75010067	100	75010296	75
0922248	132	601072	18	719...		75010068	100	75010297	75
092872	132	601157	66	719118	108	75010069	100		
092930	132	601278	40			75010085	68	750103..	
		601629	40	726...				75010300	91
		601694	41	726473	115	750101..		75010301	92
600...		601709	89			75010180	101	75010325	90
600232	48	601768	43	728...				75010329	93
600234	72	601819	18	728393	116			75010350	65
600241	64	601820	18	728726	109	750102..		75010352	65
600256	67	601821	18	728868	112	75010210	88	75010365	76
600263	47	601835	66			75010211	88	75010366	76
600265	69	601979	43	730...		75010212	88	75010367	76
600267	69			730040	112	75010213	88	75010368	76
600504	126			730041	112	75010242	71	75010393	97
600843	129	602...		730150	110	75010270	98		
600844	129	602036	64			75010271	98	750104..	
600845	129	602037	19	750..		75010272	98	75010402	94
600849	129	602038	19	7500000041	95	75010285	49	75010421	96
600850	129	602039	19			75010286	49		
600851	129	602040	19	750100..		75010287	49	751...	
600874	129	602041	19	75010008	41	75010290	74	75111062	105
600991	129	602042	19	75010028	70	75010291	74	75111063	105

Summary of Types

KATHREIN

The articles are listed by order number in numerical order.

Order No.	Page	Order No.	Page	Order No.	Page	Order No.	Page	Order No.	Page
752...		75310426	130	764499	105	770...		774...	
752183	41	75310465	125			770144	105	774846	73
		75310466	125	765...		770145	105		
7530...				765814	105	770146	105	775...	
7530000006	128	759...		765815	105	770147	105	775130	44
7530000007	124	759044	131	765816	105	770148	105	775738	46
7530000008	124			765818	105	770149	105	775838	46
7530000010	106	762...		765819	105	770510	105		
		762943	44	765820	105	770511	105	776...	
				765821	105	770512	105	776165	89
7531....		763...		765823	105	770513	105	776167	89
75310237	130	763715	44	765824	105	770514	105	776202	89
75310243	127			765825	105	770515	105		
75310244	127	764...		765826	105	770516	105	790...	
75310245	127	764485	105	765828	105	770517	105	790277	114
75310322	130	764486	105	765829	105	770518	105	790717	113
75310335	130	764487	105			770519	105	790718	113
75310384	130	764488	105	768...		770520	105	790719	113
75310386	125	764489	105	768331	106	770521	105		
75310411	126	764491	105	768332	106	770776	45	793...	
75310412	126	764493	105	768333	106	770777	45	793192	111
75310413	126	764494	105	768334	106			793194	111
75310414	126	764495	105	768335	106	772...		793196	111
75310415	126	764496	105	768336	106	772500	42		
75310416	130	764497	105	768494	70	772501	42		

The articles are listed by order number in numerical order.

K No.*	Page	K No.*	Page
K52...		K53...	
K522217	48	K5332187	43
K522257	72	K5332188	43
K523057	64		
K523058	64		
K5231187	40	K61...	
K5231188	40	K611521	129
K523157	67	K611522	129
K5231817	18	K611523	129
K5231827	18	K611541	129
K5231837	18	K611542	129
K5231847	18	K611543	129
K5231857	18	K611561	129
K5231867	18	K611562	129
K523417	41	K61301	126
K5234517	66		
K5234527	66		
K5234817	19	K73...	
K5234827	19	K733147	89
K5234837	19		
K5234847	19		
K5234857	19		
K5234867	19		
K524017	47		
K5240517	69		
K5240527	69		

Antenna Systems 47...88 MHz



Superturndisk Antenna Station "Belo Horizonte", Brazil



- Antenna array of straight dipole panels (page 18) for different radiation patterns, especially suitable for mounting on square masts.

Input	Connectors according to IEC, EIA or DIN.
Max. power	According to customer's requirements.
Frequency	One channel in Band I (47...88 MHz)
VSWR, typically	< 1.05 in one channel
Impedance	50 Ω
Polarization	Horizontal
Internal connections	Connectors according to IEC, EIA or DIN are used throughout the system, allowing easy assembly and maintenance.
Vertical radiation pattern	Null fill and beam tilt upon request.
Horizontal radiation pattern	Omnidirectional, directional or custom-designed.
Half antenna splitting	Upon request, the antenna can be divided into two halves (for emergency operation and maintenance). The two halves are connected by a 2-way power splitter or patch panel.
Pressurization	Splitters and connecting cables can be supplied with dry air (please specify when ordering).
Grounding	Via mounting parts.
Max. wind velocity	240 km/h

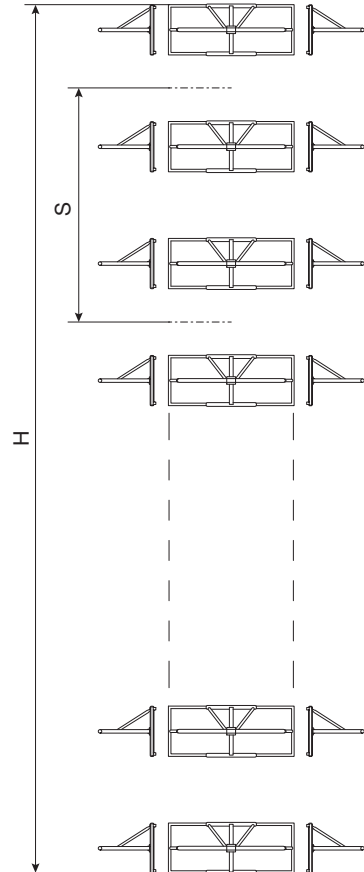

No. of bays	Panels per bay	Gain* in dBd	Weight in kg (without mounting hardware)						Windload in kN (160 km/h)						Antenna height H in m (Spacing S in m)					
			Frequency in MHz						Frequency in MHz						Frequency in MHz					
			47-54 2 ¹⁾	54-61 3 ¹⁾ 2 ²⁾	60-68 4 ¹⁾ 3 ²⁾	66-72 4 ²⁾	76-82 5 ²⁾	82-88 6 ²⁾	47-54 2 ¹⁾	54-61 3 ¹⁾ 2 ²⁾	60-68 4 ¹⁾ 3 ²⁾	66-72 4 ²⁾	76-82 5 ²⁾	82-88 6 ²⁾	47-54 2 ¹⁾	54-61 3 ¹⁾ 2 ²⁾	60-68 4 ¹⁾ 3 ²⁾	66-72 4 ²⁾	76-82 5 ²⁾	82-88 6 ²⁾
1	2	5.4	300	270	240	220	210	200	3.7	3.3	2.9	2.7	2.4	2.2	4.5	4.0	3.6	3.3	2.9	2.7
	3	3.5	450	400	350	320	300	300	6.2	5.4	4.8	4.4	3.9	3.7						
	4	2.0	620	540	460	440	420	400	7.4	6.5	5.8	5.3	4.7	4.4						
2	2	8.4	620	540	460	440	420	400	7.4	6.5	5.8	5.3	4.7	4.4	10.9 (6.4)	9.6 (5.6)	8.6 (5.0)	8.0 (4.7)	7.0 (4.1)	6.5 (3.8)
	3	6.6	950	840	750	700	660	630	12.4	10.9	9.7	8.9	7.8	7.3						
	4	5.0	1250	1100	970	900	850	800	14.9	13.0	11.6	10.7	9.4	8.8						
4	2	11.5	1250	1100	970	900	850	800	14.9	13.0	11.6	10.7	9.4	8.8	23.7 (6.4)	20.8 (5.6)	18.6 (5.0)	17.4 (4.7)	15.2 (4.1)	14.1 (3.8)
	3	9.6	1750	1550	1480	1360	1300	1250	24.9	21.8	19.3	17.8	15.7	14.7						
	4	8.1	2500	2200	1960	1800	1710	1630	29.7	26.0	23.1	21.3	18.8	17.6						
6	2	13.3	1750	1550	1480	1360	1300	1250	22.3	19.5	17.3	16.0	14.1	13.2	36.5 (6.4)	32.0 (5.6)	28.6 (5.0)	26.7 (4.7)	23.3 (4.1)	21.7 (3.8)
	3	11.4	2770	2450	2200	2000	1900	1820	37.3	32.6	29.0	26.6	23.5	22.0						
	4	9.9	3700	3260	2920	2700	2550	2420	44.6	39.0	34.7	32.0	28.2	26.4						
8	2	14.5	2500	2200	1960	1800	1710	1630	29.7	26.0	23.1	21.3	18.8	17.6	49.3 (6.4)	43.2 (5.6)	38.6 (5.0)	36.1 (4.7)	31.5 (4.1)	29.3 (3.8)
	3	12.6	3700	3260	2920	2700	2550	2420	49.7	43.5	38.6	35.5	31.3	29.3						
	4	11.1	4920	4350	3900	3560	3370	3200	59.4	52.0	46.2	42.6	37.6	35.2						

* Attenuation of the internal cabling and the gain-decrease in case of null fill in the vertical radiation pattern are not considered.
Approximate values for gain decrease:
cable attenuation: 0.2 – 0.5 dB
null fill: 0.3 – 1.0 dB
Gain figures are valid for the direction of maximum radiation (see diagrams on following page).

¹⁾ System B, Europa
²⁾ System M, N, America

Horizontal Radiation Patterns

Examples of typical horizontal antenna arrays and their **horizontal** radiation patterns for optimal mast dimensions.

Equal power splitting

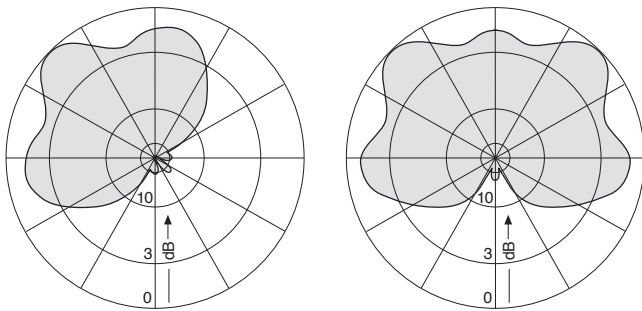
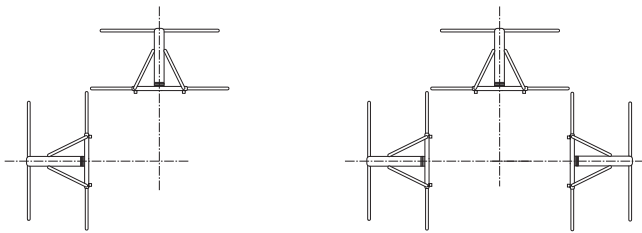

Equal power splitting

Different power splitting

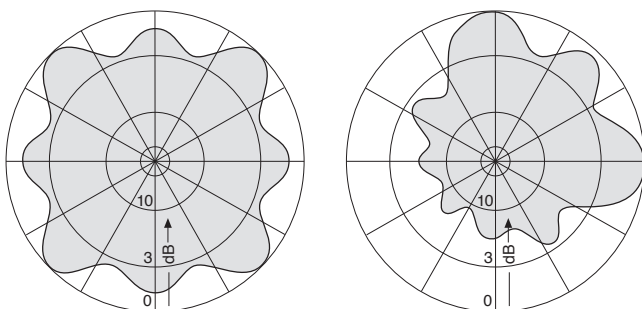
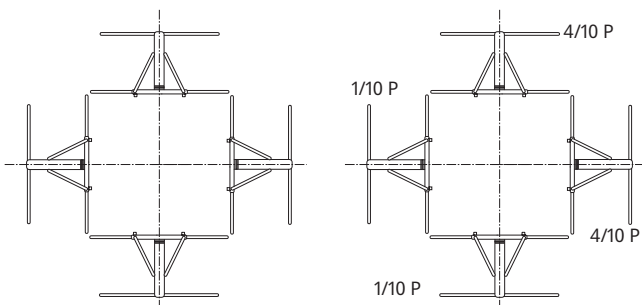

Vertical Radiation Patterns

Examples of typical **vertical** radiation patterns*) for several bays of identical, vertically stacked antenna arrays.

2 bays

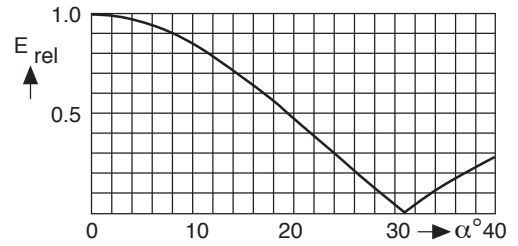

4 bays

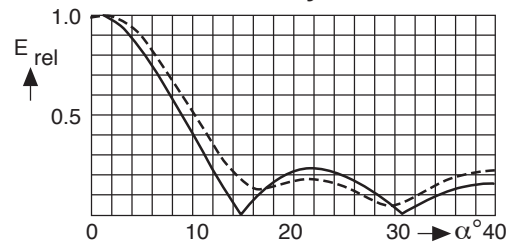

6 bays

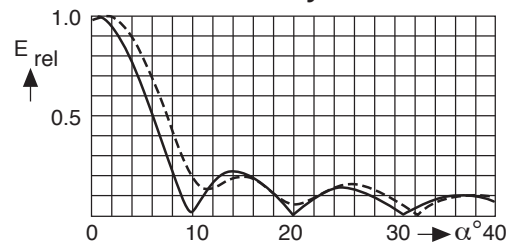

8 bays

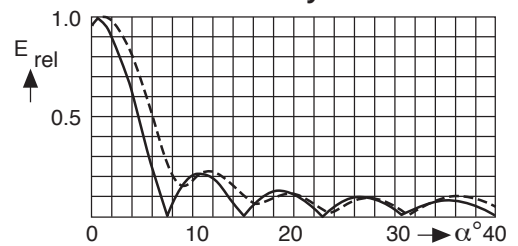

*) ——— without null fill
----- with null fill and beam tilt

- Antenna array of bent dipole panels (page 19) for different radiation patterns, especially suitable for mounting on triangular or round masts.

Input	Connectors according to IEC, EIA or DIN.
Max. power	According to customer's requirements.
Frequency	One channel in Band I (47...88 MHz)
VSWR, typically	< 1.05 in one channel
Impedance	50 Ω
Polarization	Horizontal
Internal connections	Connectors according to IEC, EIA or DIN are used throughout the system, allowing easy assembly and maintenance.
Vertical radiation pattern	Null fill and beam tilt upon request.
Horizontal radiation pattern	Omnidirectional, directional or custom-designed.
Half antenna splitting	Upon request, the antenna can be divided into two halves (for emergency operation and maintenance). The two halves are connected by a 2-way power splitter or patch panel.
Pressurization	Splitters and connecting cables can be supplied with dry air (please specify when ordering).
Grounding	Via mounting parts.
Max. wind velocity	240 km/h

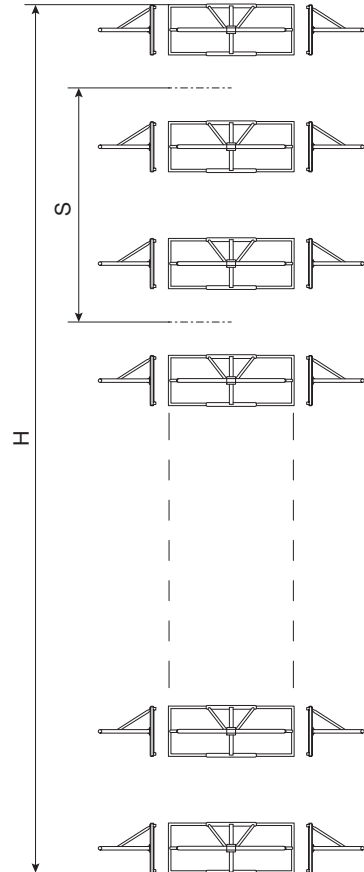

No. of bays	Panels per bay	Gain in dBd	Weight in kg (without mounting hardware)						Windload in kN (160 km/h)						Antenna height H in m (Spacing S in m)					
			Frequency in MHz						Frequency in MHz						Frequency in MHz					
			47-54 2 ¹⁾	54-61 3 ¹⁾ 2 ²⁾	60-68 4 ¹⁾ 3 ²⁾	66-72 4 ²⁾	76-82 5 ²⁾	82-88 6 ²⁾	47-54 2 ¹⁾	54-61 3 ¹⁾ 2 ²⁾	60-68 4 ¹⁾ 3 ²⁾	66-72 4 ²⁾	76-82 5 ²⁾	82-88 6 ²⁾	47-54 2 ¹⁾	54-61 3 ¹⁾ 2 ²⁾	60-68 4 ¹⁾ 3 ²⁾	66-72 4 ²⁾	76-82 5 ²⁾	82-88 6 ²⁾
1	2	3.9	310	275	250	235	205	195	4.1	3.3	2.9	2.7	2.4	2.2	4.5	4.0	3.6	3.3	2.9	2.7
	3	1.7	470	410	375	350	310	290	5.6	4.9	4.4	4.1	3.6	2.9						
2	2	6.9	650	550	500	470	410	390	8.1	6.5	5.8	5.3	4.7	4.4	10.9 (6.4)	9.6 (5.6)	8.6 (5.0)	8.0 (4.7)	7.0 (4.1)	6.5 (3.8)
	3	4.7	990	820	750	700	620	580	11.3	9.9	8.9	8.2	7.1	5.9						
4	2	9.9	1310	1095	1000	935	825	775	16.3	13.0	11.6	10.7	9.4	8.8	23.7 (6.4)	20.8 (5.6)	18.6 (5.0)	17.4 (4.7)	15.2 (4.1)	14.1 (3.8)
	3	7.7	1910	1645	1500	1405	1235	1165	22.5	19.8	17.8	16.3	14.3	11.8						
6	2	11.7	1910	1645	1500	1405	1235	1165	24.4	19.5	17.3	16.0	14.1	13.2	36.5 (6.4)	32.0 (5.6)	28.6 (5.0)	26.7 (4.7)	23.3 (4.1)	21.7 (3.8)
	3	9.5	2820	2645	2250	2105	1855	1745	33.8	29.6	26.6	24.5	21.4	17.7						
8	2	12.9	2600	2190	2000	1870	1650	1550	32.5	26.0	23.1	21.3	18.8	17.6	49.3 (6.4)	43.2 (5.6)	38.6 (5.0)	36.1 (4.7)	31.5 (4.1)	29.3 (3.8)
	3	10.7	3800	3290	3000	2810	2470	2330	45.0	39.5	35.5	32.6	28.5	23.5						

* Attenuation of the internal cabling and the gain-decrease in case of null fill in the vertical radiation pattern are not considered.

Approximate values for gain decrease:
 cable attenuation: 0.2 – 0.5 dB
 null fill: 0.3 – 1.0 dB

Gain figures are valid for the direction of maximum radiation (see diagrams on following page).

¹⁾ System B, Europa

²⁾ System M, N, America

Horizontal Radiation Patterns

Examples of typical horizontal antenna arrays and their **horizontal** radiation patterns for optimal mast dimensions.

Equal power splitting

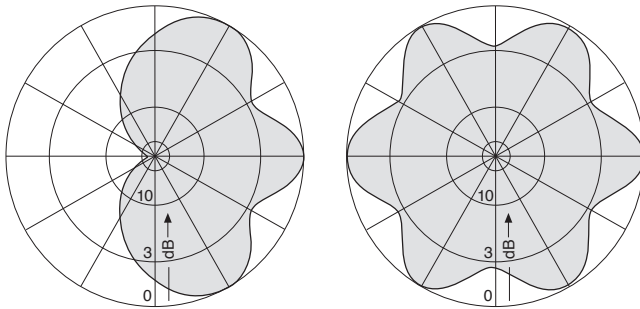
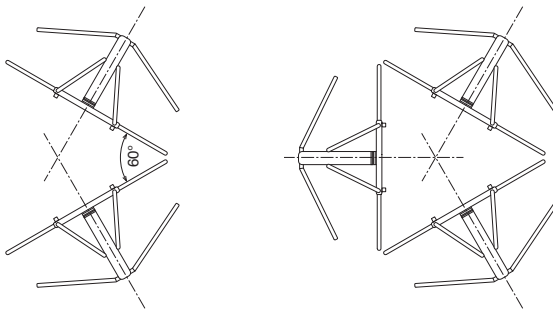

Different power splitting

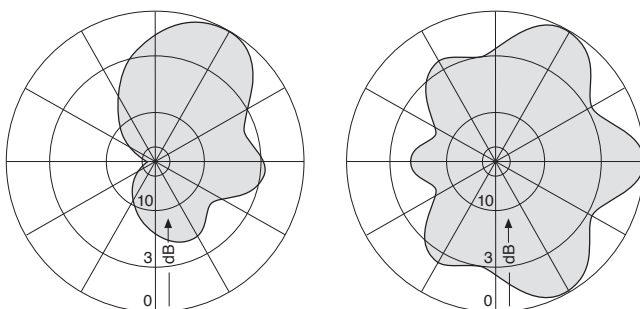
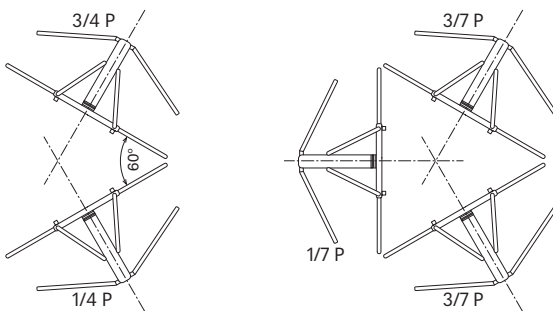

Vertical Radiation Patterns

Examples of typical **vertical** radiation patterns*) for several bays of identical, vertically stacked antenna arrays.

2 bays

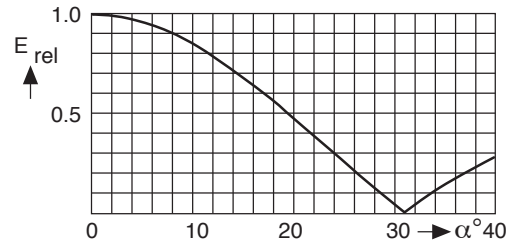

4 bays

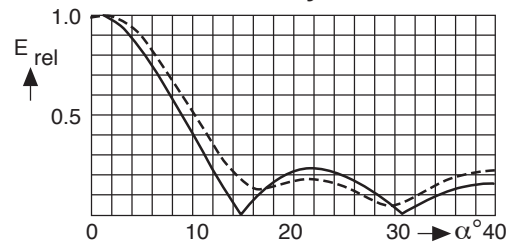

6 bays

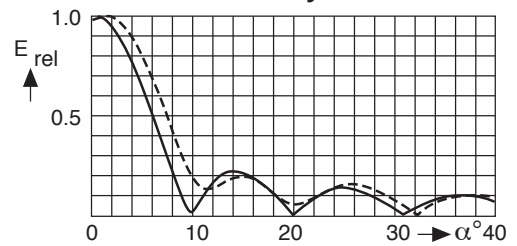

8 bays

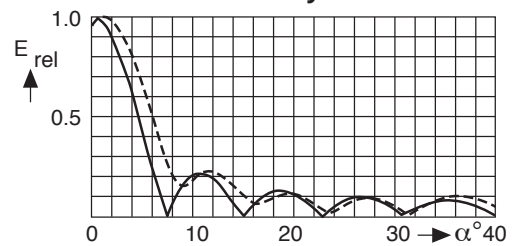

*) — without null fill
 - - - with null fill and beam tilt

- Superturnstile Antenna made of hot-dip galvanized steel for mounting on top of mast.

Input	Connectors according to IEC, EIA or DIN.
Max. power	According to customer's requirements, 12 kW max. per bay.
Frequency	One channel in Band I (54...88 MHz)
VSWR, typically	< 1.05 in one operating channel.
Impedance	50 Ω
Polarization	Horizontal
Vertical radiation pattern	Null fill and beam tilt upon request.
Horizontal radiation pattern	Omnidirectional
Half antenna splitting	Upon request, the antenna can be divided into two halves (for emergency operation and maintenance). The two halves are connected by a 2-way power splitter or patch panel.
Internal connections	The radiating elements are fed with coaxial connecting cables and hybrid couplers or power splitters. Connectors according to IEC, EIA or DIN are used throughout the system, allowing easy assembly and maintenance.
Mounting	On top of existing structure.
Ice protection	The radiating slots are protected by a fiberglass cover.
Grounding	Via mounting parts.
Max. wind velocity	As required.

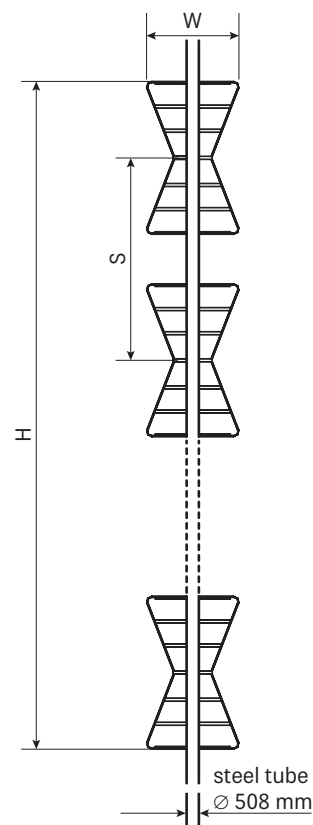

No. of bays	Gain* in dBd	Approx. weight in kg (incl. steel tube)					Approx. wind load incl. steel tube in kN (160 km/h)					Approx. height H in m (spacing S in m)					Approx. width W in m				
		Frequency in MHz					Frequency in MHz					Frequency in MHz					Frequency in MHz				
		54-60	60-66	66-72	76-82	82-88	54-60	60-66	66-72	76-82	82-88	54-60	60-66	66-72	76-82	82-88	54-60	60-66	66-72	76-82	82-88
1	1	1360	1270	1220	1090	680	8.5	7.5	6.8	5.5	3.1	3.5	3.2	2.9	2.5	2.4	3.4	3.1	2.9	2.6	2.1
2	4	2700	2490	2380	2130	1250	17.0	14.9	13.5	11.1	6.3	8.8 (5.3)	8.0 (4.8)	7.9 (4.4)	6.3 (3.8)	5.9 (3.5)	3.4	3.1	2.9	2.6	2.1
3	5.8	4030	3710	3530	3170	1810	25.5	22.4	20.3	16.6	9.4	14.1 (5.3)	12.8 (4.8)	11.7 (4.4)	10.1 (3.8)	9.4 (3.5)	3.4	3.1	2.9	2.6	2.1
4	7	5370	4940	4690	4210	2390	34.0	29.9	27.0	22.2	12.5	19.4 (5.3)	17.6 (4.8)	16.2 (4.4)	14.0 (3.8)	13.0 (3.5)	3.4	3.1	2.9	2.6	2.1

* Attenuation of the internal cabling and the gain-decrease in case of null fill in the vertical radiation pattern are not considered.

Approximate values for gain decrease:

cable attenuation: 0.2 – 0.4 dB

null fill: 0.3 – 1.0 dB

Gain figures are valid for the direction of maximum radiation (see diagrams on following page).

Typical Horizontal Radiation Pattern
(at mid-band)

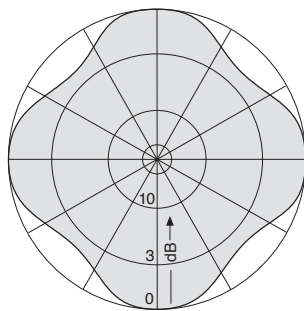

Vertical Radiation Patterns

Examples of typical **vertical** radiation patterns*) for several bays of identical, vertically stacked superturnstiles.

1 bay

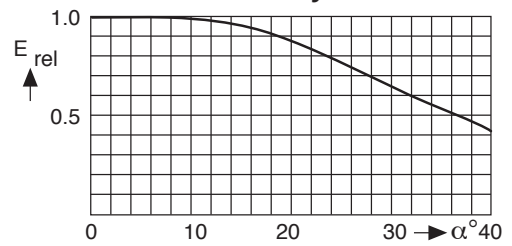

2 bays

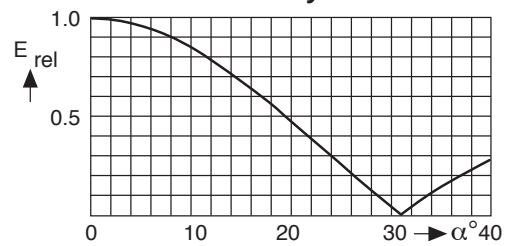

3 bays

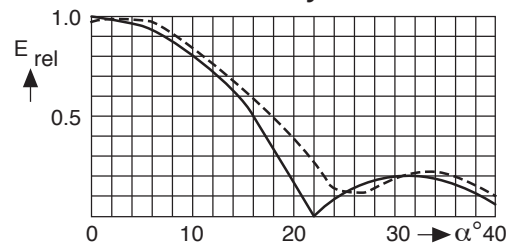

4 bays

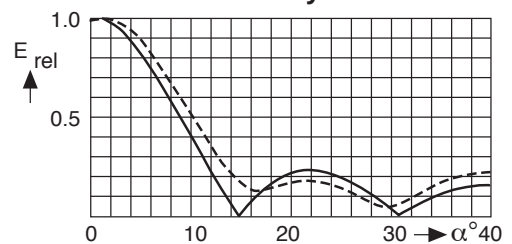

*) ——— without null fill
 - - - - - with null fill and beam tilt

Antennas for TV in lower VHF Band 47...88 MHz

- Especially suitable for square masts.

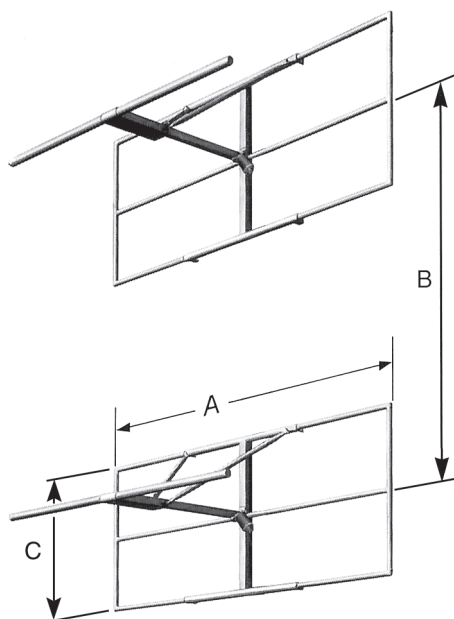

Length see table

Radiation Patterns
(at mid-band)

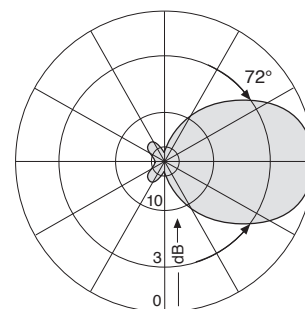

Horizontal Radiation Pattern

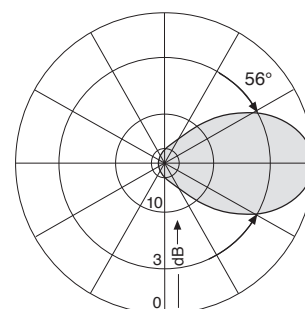

Vertical Radiation Pattern

Order No.	601070 K5231817	601071 K5231827	601072 K5231837	601819 K5231847	601820 K5231857	601821 K5231867
Input	2 x 7-16 female					
Max. power	3 kW per input					
Frequency	47 – 54 MHz	54 – 61 MHz	60 – 68 MHz	66 – 72 MHz	76 – 82 MHz	82 – 88 MHz
Channel	2	3	4	4	5	6
	System B, Europa System M, N, America					
VSWR	< 1.15					
Gain (at mid-band)	7.5 dBd					
Impedance	50 Ω					
Polarization	Horizontal					
Weight	140 kg	124 kg	110 kg	100 kg	94 kg	89 kg
Wind load in kN (at 160 km/h)						
frontal	2.50	2.20	1.95	1.80	1.60	1.50
lateral	1.25	1.10	0.95	0.90	0.80	0.75
Max. wind velocity	240 km/h					
Dimensions in mm (approx.)						
A	3360	2960	2640	2470	2165	2015
B	3200	2800	2500	2340	2040	1900
C	1330	1180	1060	995	875	820

Material:	Hot-dip galvanized steel. Radome: Fiberglass.
Mounting:	Mounting hardware and mounting dimensions upon request.
Grounding:	Via mounting parts.
Ice protection:	Even under severe icy conditions the antenna is still functional due to its heavy-duty construction and the fiberglass covers for the feeding points.
Scope of supply:	Antenna consisting of two half-wave dipoles with reflector screens.
Special features:	The antenna is shipped dismantled.

Panel Antenna

47...88 MHz

KATHREIN

Polarization

H

- Especially suitable for triangular and round masts.

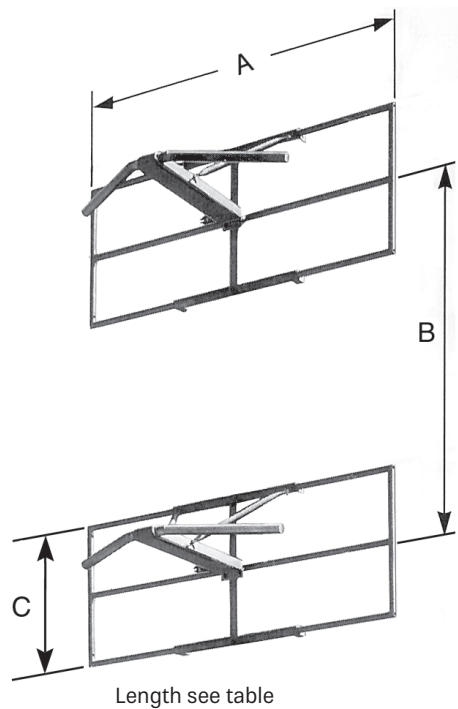

Radiation Patterns
(at mid-band)

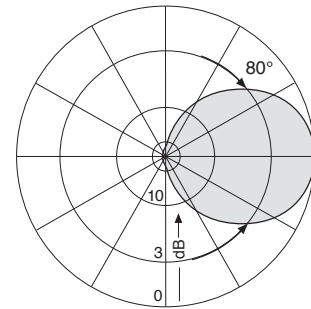

Horizontal Radiation Pattern

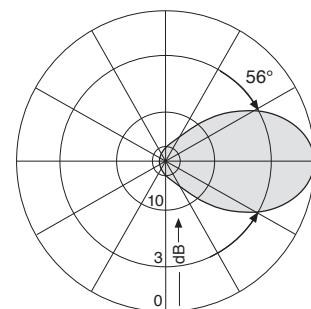

Vertical Radiation Pattern

Order No.	602037 K5234817	602038 K5234827	602039 K5234837	602040 K5234847	602041 K5234857	602042 K5234867
Input	2 x 7-16 female					
Max. power	3 kW per input					
Frequency	47 - 54 MHz	54 - 61 MHz	60 - 68 MHz	66 - 72 MHz	76 - 82 MHz	82 - 88 MHz
Channel	2	3	4	4	5	6
	System B, Europa System M, N, America					
VSWR	< 1.15					
Gain (at mid-band)	7 dBd					
Impedance	50 Ω					
Polarization	Horizontal					
Weight	148 kg	137 kg	125 kg	117 kg	103 kg	97 kg
Wind load in kN (at 160 km/h)						
frontal	2.50	2.20	2.00	1.85	1.60	1.45
lateral	1.30	1.20	1.10	1.00	0.90	0.85
Max. wind velocity	240 km/h					
Dimensions in mm (approx.)						
A	3360	2960	2688	2470	2155	2000
B	3200	2800	2500	2340	2040	1900
C	1330	1180	1060	995	875	820

Material:	Hot-dip galvanized steel. Radome: Fiberglass.
Mounting:	Mounting hardware and mounting dimensions upon request.
Grounding:	Via mounting parts.
Ice protection:	Even under icy conditions the antenna keeps operating due to the radomes covering the feed areas.
Scope of supply:	Antenna consisting of two half-wave dipoles with reflector screens.
Special features:	The antenna is shipped dismounted.



Broadcast Station "Steinkimmen", Germany

Antenna Systems 87.5–108 MHz

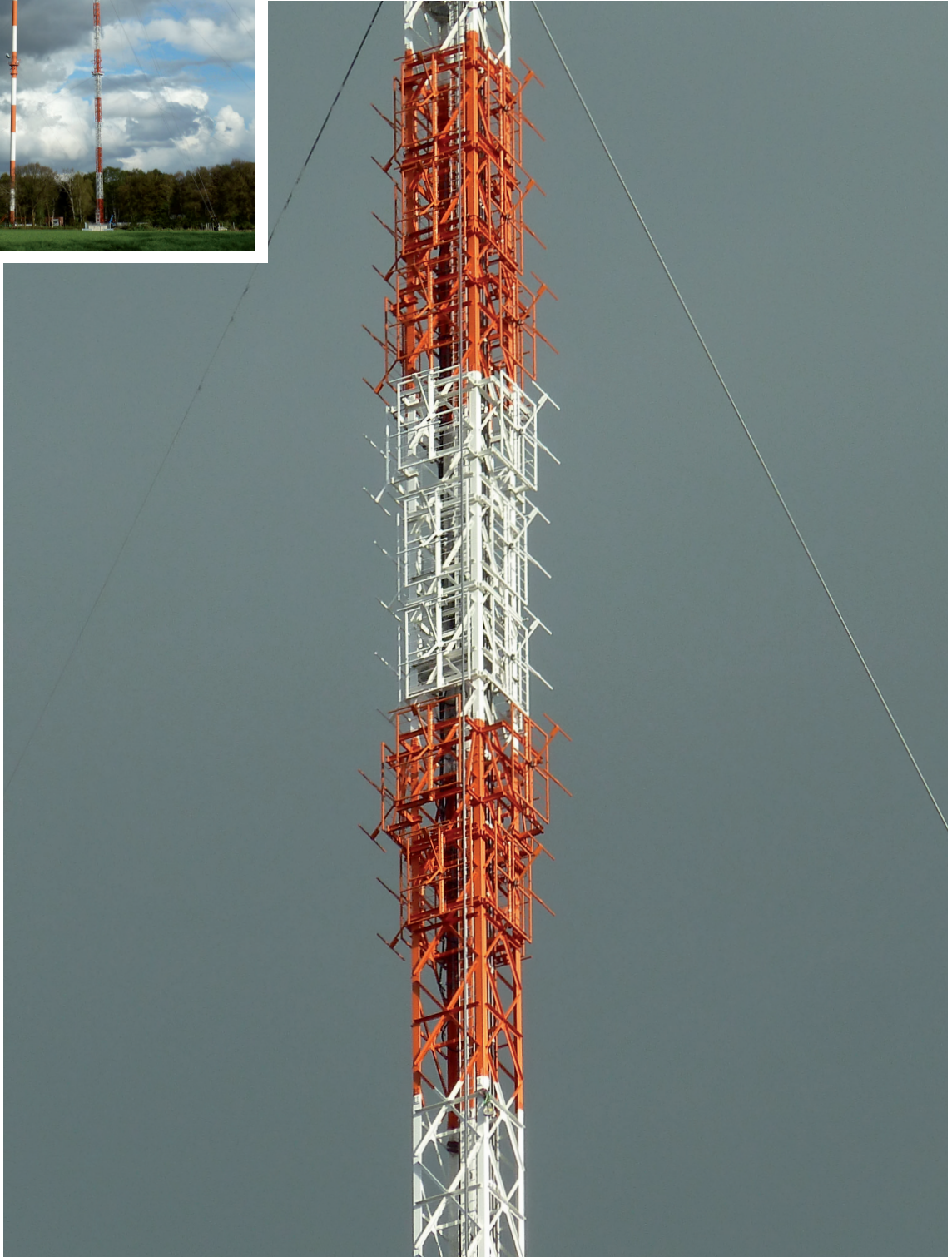

Polarization H

- Antenna array of dipole panels (page 40) for different radiation patterns.
- Especially suitable for mounting on square masts.
- The feeder network is made up of coaxial power splitters and flexible connecting cables in accordance with the radiation patterns specification and the transmitter power.

Input	Connectors according to IEC, EIA or DIN.
Max. power	According to customer's requirements.
Frequency	87.5 – 108 MHz
VSWR, typically	< 1.2 throughout the whole frequency range. Lower VSWR for parts of band upon request.
Impedance	50 Ω
Polarization	Horizontal
Internal connections	Connectors according to IEC, EIA or DIN are used throughout the system, allowing easy assembly and maintenance.
Vertical radiation pattern	Null fill and beam tilt upon request.
Horizontal radiation pattern	Omnidirectional, directional or custom-designed.
Half antenna splitting	Upon request, the antenna can be divided into two halves (for emergency operation and maintenance). The two halves are connected by a 2-way power splitter or patch panel.
Pressurization	Splitters and connecting cables can be supplied with dry air (please specify when ordering).
Grounding	Via mounting parts.
Max. wind velocity	240 km/h

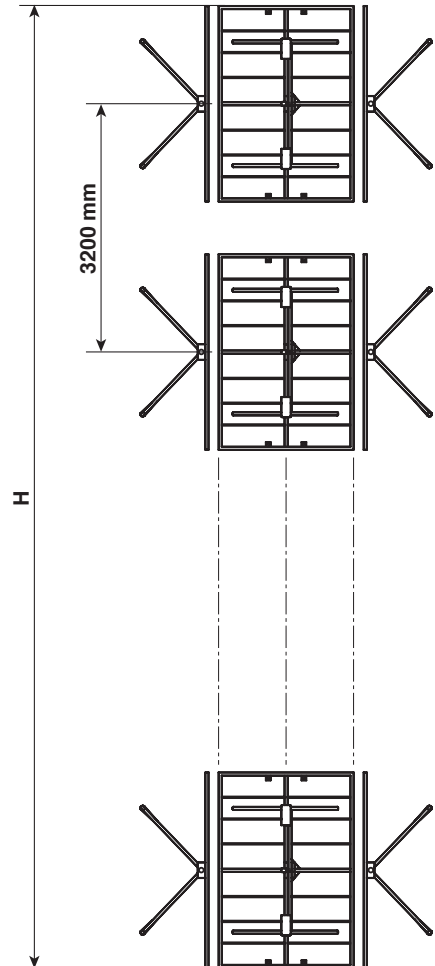

No. of bays	Panels per bay	Gain*		Weight (without mounting hardware) kg	Antenna height H m	Windload (v = 160 km/h) kN
		dBd	times			
1	2	5.0	3.2	140	2.5	2.4
	3	3.5	2.2	210		3.9
	4	2.0	1.6	280		4.8
2	2	8.0	6.3	280	5.7	4.8
	3	6.5	4.5	420		7.8
	4	5.0	3.2	550		9.6
4	2	11.0	12.6	550	12.1	9.6
	3	9.5	8.9	830		15.6
	4	8.0	6.3	1120		19.3
6	2	12.8	19.1	830	18.5	14.4
	3	11.3	13.0	1250		23.4
	4	9.7	9.3	1660		28.9
8	2	14.0	25.1	1120	24.9	19.3
	3	12.5	17.8	1660		31.3
	4	11.0	12.6	2200		38.5

* Attenuation of the internal cabling and the gain-decrease in case of null fill in the vertical radiation pattern are not considered.
 Approximate values for gain decrease:
 cable attenuation: 0.2 – 0.5 dB
 null fill: 0.3 – 1.0 dB
 Gain figures are valid for the direction of maximum radiation (see diagrams on following page).

Horizontal Radiation Patterns

Examples of typical horizontal antenna arrays and their **horizontal** radiation patterns for optimal mast dimensions.

Equal power splitting

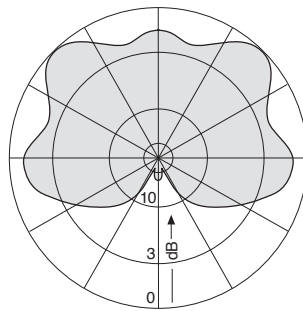
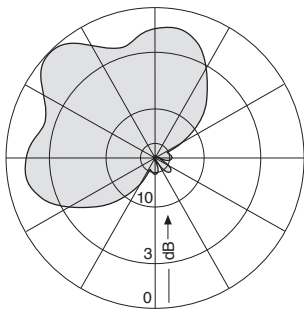
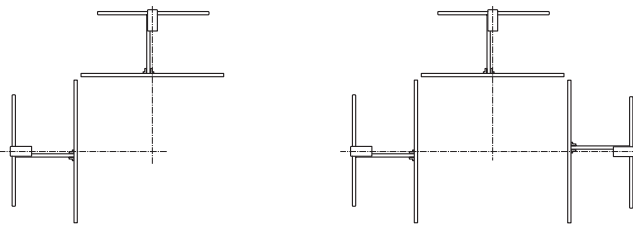

Equal power splitting

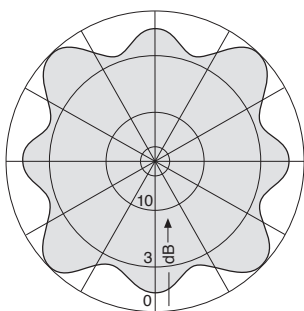
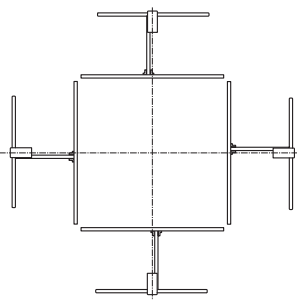

Different power splitting

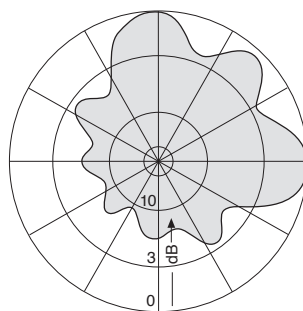
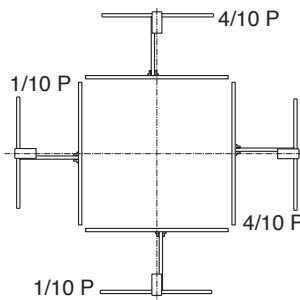

Vertical Radiation Patterns

Examples of typical **vertical** radiation patterns*) for several bays of identical, vertically stacked antenna arrays.

2 bays

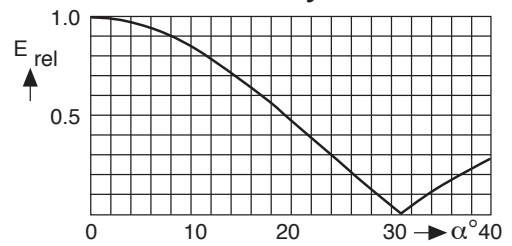

4 bays

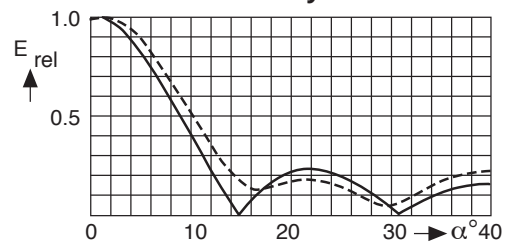

6 bays

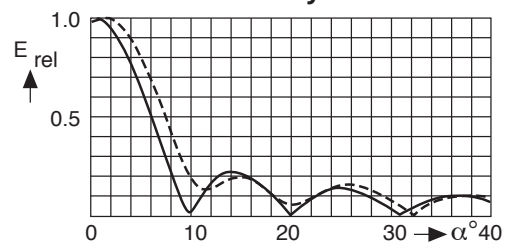

8 bays

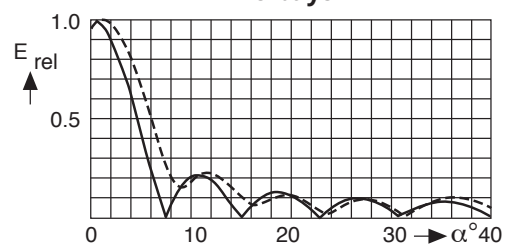

*) ——— without null fill
 - - - - with null fill and beam tilt

Polarization V

- Antenna array of dipole panels (page 40) for different radiation patterns.
- Especially suitable for mounting on square masts.
- The feeder network is made up of coaxial power splitters and flexible connecting cables in accordance with the radiation patterns specification and the transmitter power.

Input	Connectors according to IEC, EIA or DIN.
Max. power	According to customer's requirements.
Frequency	87.5 – 108 MHz
VSWR, typically	< 1.2 throughout the whole frequency range. Lower VSWR for parts of band upon request.
Impedance	50 Ω
Polarization	Vertical
Internal connections	Connectors according to IEC, EIA or DIN are used throughout the system, allowing easy assembly and maintenance.
Vertical radiation pattern	Null fill and beam tilt upon request.
Horizontal radiation pattern	Omnidirectional, directional or custom-designed.
Half antenna splitting	Upon request, the antenna can be divided into two halves (for emergency operation and maintenance). The two halves are connected by a 2-way power splitter or patch panel.
Pressurization	Splitters and connecting cables can be supplied with dry air (please specify when ordering).
Grounding	Via mounting parts.
Max. wind velocity	240 km/h

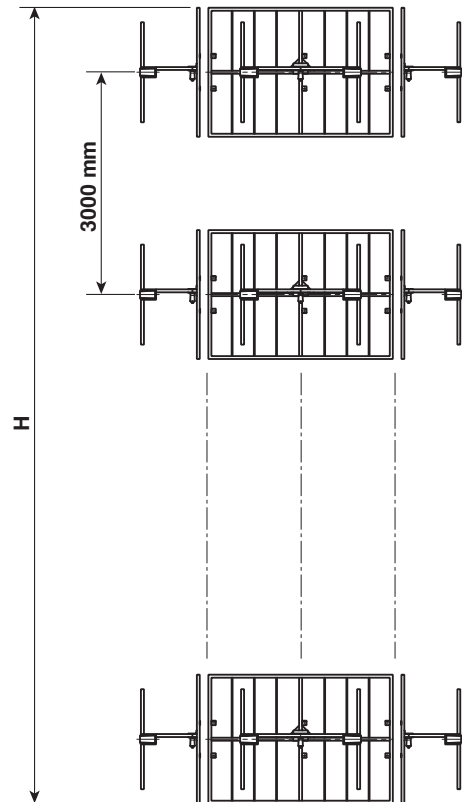

No. of bays	Panels per bay	Gain* (at mid-band)		Weight (without mounting hardware) kg	Antenna height H m	Windload (v = 160 km/h) kN
		dBd	times			
1	2	5.4	3.5	140	1.8	2.3
	3	3.7	2.3	210		3.8
	4	2.3	1.7	280		4.7
2	2	8.4	6.9	280	4.8	4.7
	3	6.7	4.7	420		7.7
	4	5.3	3.4	550		9.3
4	2	11.4	13.8	550	10.8	9.3
	3	9.7	9.3	830		15.3
	4	8.3	6.8	1120		18.6
6	2	13.2	20.9	830	16.8	14.0
	3	11.5	14.1	1250		23.0
	4	10.1	10.2	1660		27.9
8	2	14.4	27.5	1120	25.8	18.6
	3	12.7	18.6	1660		30.6
	4	11.3	13.5	2200		37.2

* Attenuation of the internal cabling and the gain-decrease in case of null fill in the vertical radiation pattern are not considered.
 Approximate values for gain decrease:
 cable attenuation: 0.2 – 0.5 dB
 null fill: 0.3 – 1.0 dB
 Gain figures are valid for the direction of maximum radiation (see diagrams on following page).

Horizontal Radiation Patterns

Examples of typical horizontal antenna arrays and their **horizontal** radiation patterns for optimal mast dimensions.

Equal power splitting

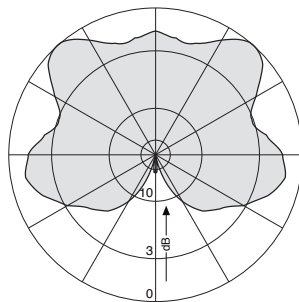
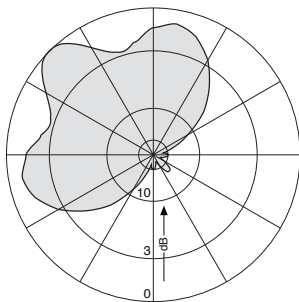
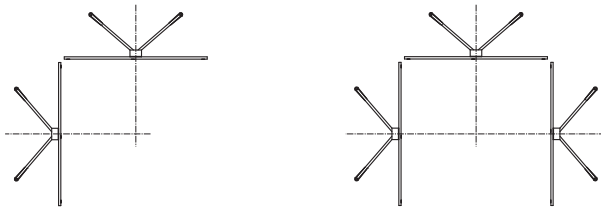

Equal power splitting

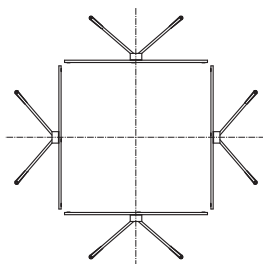

Different power splitting

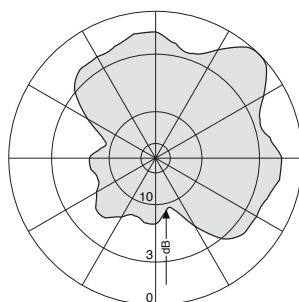
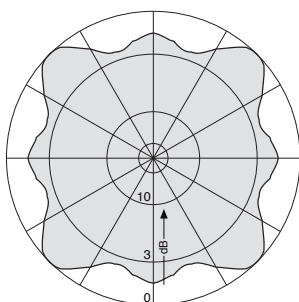
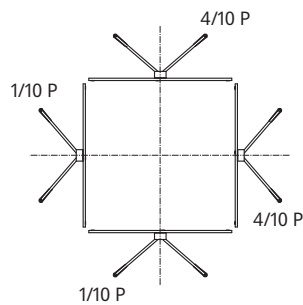

Vertical Radiation Patterns

Examples of typical **vertical** radiation patterns*) for several bays of identical, vertically stacked antenna arrays.

2 bays

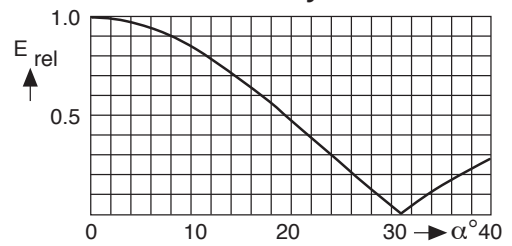

4 bays

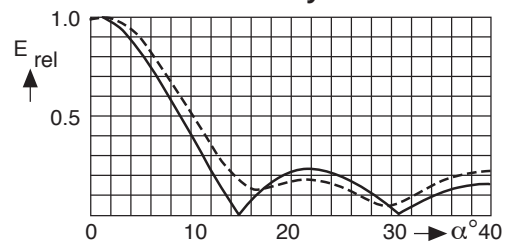

6 bays

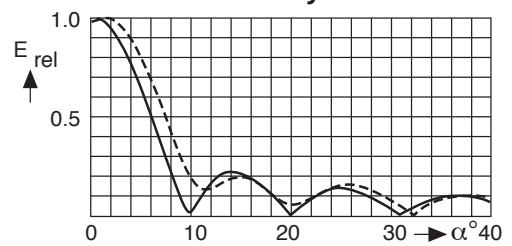

8 bays

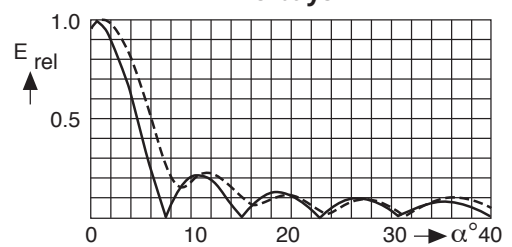

*) ——— without null fill
 - - - - with null fill and beam tilt

Polarization H

- Antenna array of dipole panels (page 41) for different radiation patterns.
- Especially suitable for mounting on triangular or round masts.
- The feeder network is made up of coaxial power splitters and flexible connecting cables in accordance with the radiation patterns specification and the transmitter power.

Input	Connectors according to IEC, EIA or DIN.
Max. power	According to customer's requirements.
Frequency	87.5 - 108 MHz
VSWR, typically	< 1.2 throughout the whole frequency range. Lower VSWR for parts of band upon request.
Impedance	50 Ω
Polarization	Horizontal
Internal connections	Connectors according to IEC, EIA or DIN are used throughout the system, allowing easy assembly and maintenance.
Vertical radiation pattern	Null fill and beam tilt upon request.
Horizontal radiation pattern	Omnidirectional, directional or custom-designed.
Half antenna splitting	Upon request, the antenna can be divided into two halves (for emergency operation and maintenance). The two halves are connected by a 2-way power splitter or patch panel.
Pressurization	Splitters and connecting cables can be supplied with dry air (please specify when ordering).
Grounding	Via mounting parts.
Max. wind velocity	240 km/h

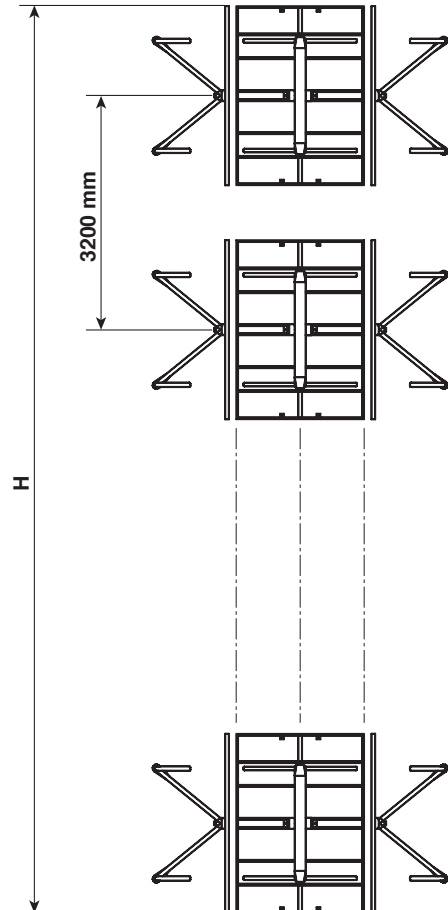

No. of bays	Panels per bay	Gain*		Weight (without mounting hardware) kg	Antenna height H m	Windload (v = 160 km/h) kN
		(at mid-band) dBd	times			
1	2	3.9	2.5	150	2.5	2.9
	3	1.7	1.5	220		4.4
2	2	6.9	4.9	290	5.7	5.9
	3	4.7	3.0	420		8.8
4	2	9.9	9.8	560	12.1	11.8
	3	7.7	5.9	850		17.5
6	2	11.7	14.8	850	18.5	17.6
	3	9.5	8.9	1290		26.3
8	2	12.9	19.5	1150	24.9	23.5
	3	10.7	11.7	1700		35.0

* Attenuation of the internal cabling and the gain-decrease in case of null fill in the vertical radiation pattern are not considered.
 Approximate values for gain decrease:
 cable attenuation: 0.2 - 0.5 dB
 null fill: 0.3 - 1.0 dB
 Gain figures are valid for the direction of maximum radiation (see diagrams on following page).

Horizontal Radiation Patterns

Examples of typical horizontal antenna arrays and their **horizontal** radiation patterns for optimal mast dimensions.

Equal power splitting

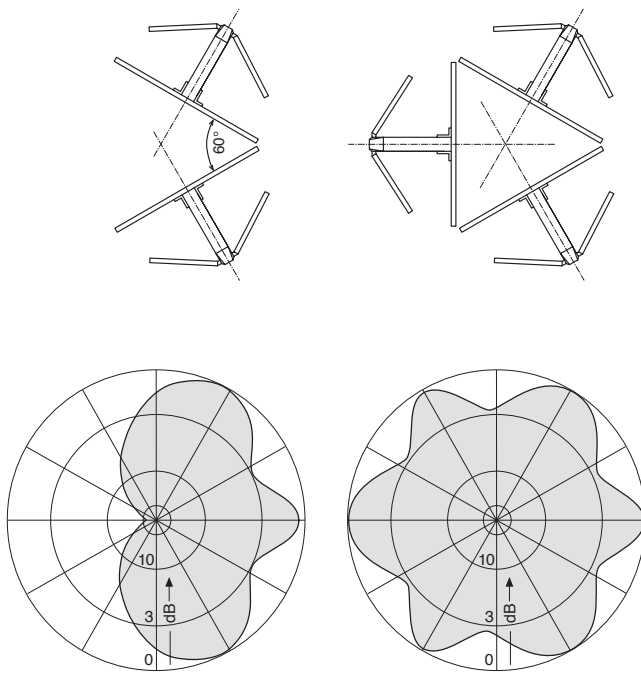

Different power splitting

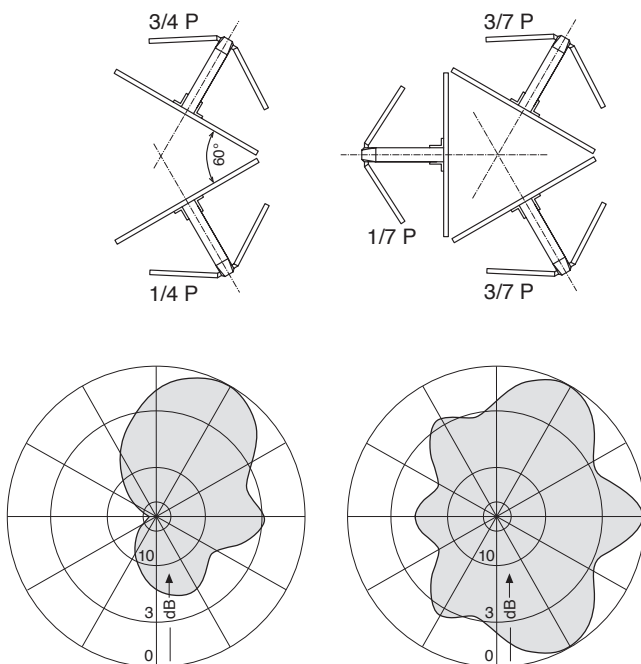

Vertical Radiation Patterns

Examples of typical **vertical** radiation patterns*) for several bays of identical, vertically stacked antenna arrays.

2 bays

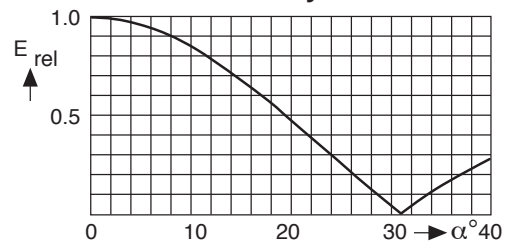

4 bays

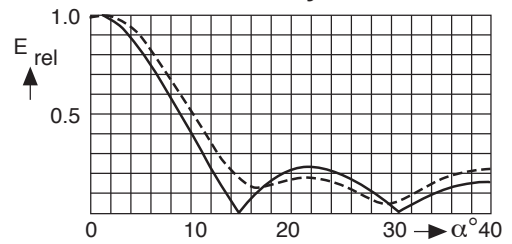

6 bays

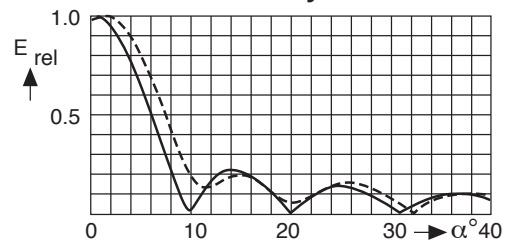

8 bays

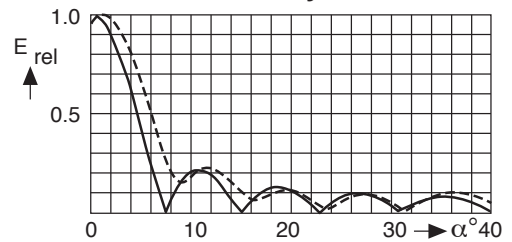

*) ——— without null fill
 - - - - - with null fill and beam tilt

Systems 87.5-108 MHz

Polarization V

- Antenna array of dipole panels (page 42) for different radiation patterns.
- Especially suitable for mounting on triangular or round masts.
- The feeder network is made up of coaxial power splitters and flexible connecting cables in accordance with the radiation patterns specification and the transmitter power.

Input	Connectors according to IEC, EIA or DIN.
Max. power	According to customer's requirements.
Frequency	87.5 – 108 MHz
VSWR, typically	< 1.2 throughout the whole frequency range. Lower VSWR for parts of band upon request.
Impedance	50 Ω
Polarization	Vertical
Internal connections	Connectors according to IEC, EIA or DIN are used throughout the system, allowing easy assembly and maintenance.
Vertical radiation pattern	Null fill and beam tilt upon request.
Horizontal radiation pattern	Omnidirectional, directional or custom-designed.
Half antenna splitting	Upon request, the antenna can be divided into two halves (for emergency operation and maintenance). The two halves are connected by a 2-way power splitter or patch panel.
Pressurization	Splitters and connecting cables can be supplied with dry air (please specify when ordering).
Grounding	Via mounting parts.
Max. wind velocity	240 km/h

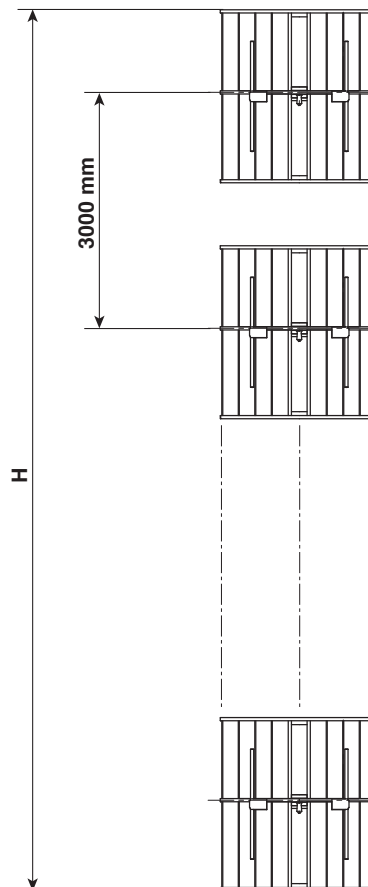

No. of bays	Panels per bay	Gain* (at mid-band)		Weight (without mounting hardware) kg	Antenna height H m	Windload (v = 160 km/h) kN
		dBd	times			
1	2	3.9	2.5	150	2.2	2.4
	3	1.7	1.5	220		3.9
2	2	6.9	4.9	290	5.2	4.8
	3	4.7	3.0	420		7.7
4	2	9.9	9.8	560	11.2	9.6
	3	7.7	5.9	850		15.5
6	2	11.7	14.8	850	17.2	14.3
	3	9.5	8.9	1290		23.2
8	2	12.9	19.5	1150	23.2	19.1
	3	10.7	11.7	1700		30.9

* Attenuation of the internal cabling and the gain-decrease in case of null fill in the vertical radiation pattern are not considered.
 Approximate values for gain decrease:
 cable attenuation: 0.2 – 0.5 dB
 null fill: 0.3 – 1.0 dB
 Gain figures are valid for the direction of maximum radiation (see diagrams on following page).

Horizontal Radiation Patterns

Examples of typical horizontal antenna arrays and their **horizontal** radiation patterns for optimal mast dimensions.

Equal power splitting

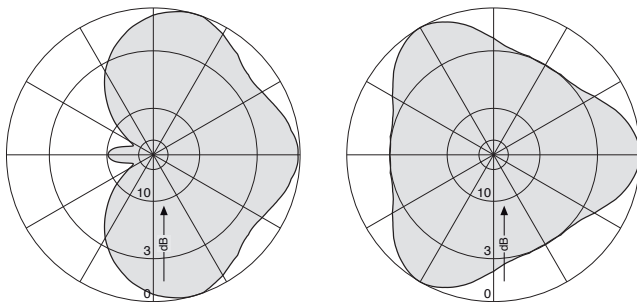
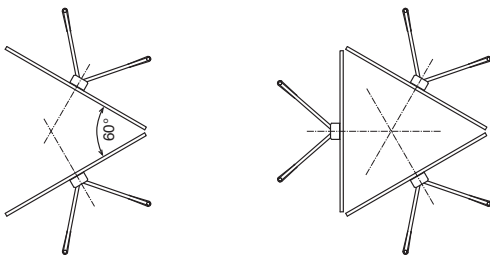

Equal power splitting

Different power splitting

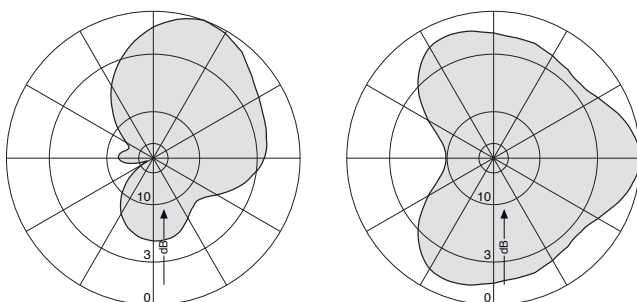
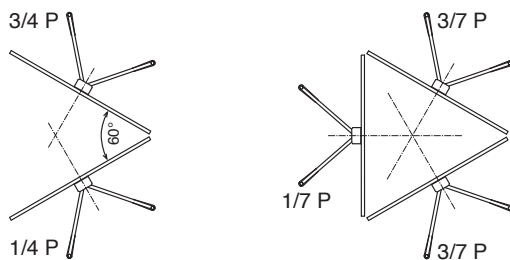

Vertical Radiation Patterns

Examples of typical **vertical** radiation patterns*) for several bays of identical, vertically stacked antenna arrays.

2 bays

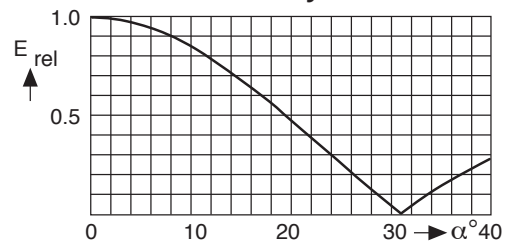

4 bays

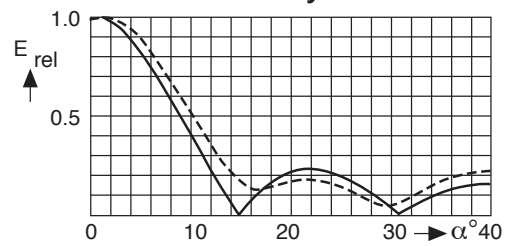

6 bays

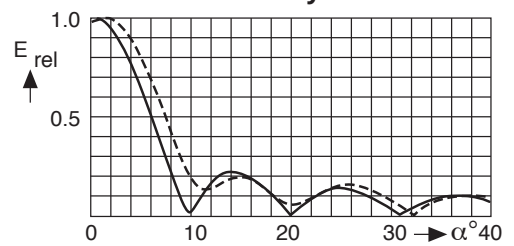

8 bays

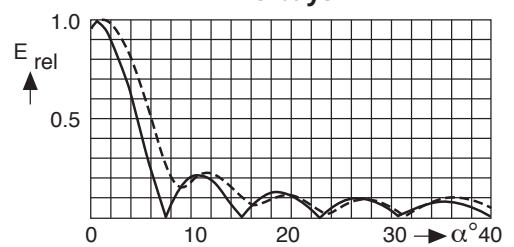

*) ——— without null fill
 - - - - - with null fill and beam tilt

Polarization

H V X

- Antenna array of circularly polarized dipole panels (page 43) for different radiation patterns.
- Especially suitable for mounting on square masts.
- The feeder network is made up of coaxial power splitters and flexible connecting cables in accordance with the radiation patterns specification and the transmitter power.

Input	Connectors according to IEC, EIA or DIN.
Max. power	According to customer's requirements.
Frequency	87.5 – 108 MHz
VSWR, typically	< 1.2 throughout the whole frequency range. Lower VSWR for parts of band upon request.
Impedance	50 Ω
Polarization	Linear, circular or elliptical
Internal connections	Connectors according to IEC, EIA or DIN are used throughout the system, allowing easy assembly and maintenance.
Vertical radiation pattern	Null fill and beam tilt upon request.
Horizontal radiation pattern	Omnidirectional, directional or custom-designed.
Half antenna splitting	Upon request, the antenna can be divided into two halves (for emergency operation and maintenance). The two halves are connected by a 2-way power splitter or patch panel.
Pressurization	Splitters and connecting cables can be supplied with dry air (please specify when ordering).
Grounding	Via mounting parts.
Max. wind velocity	240 km/h

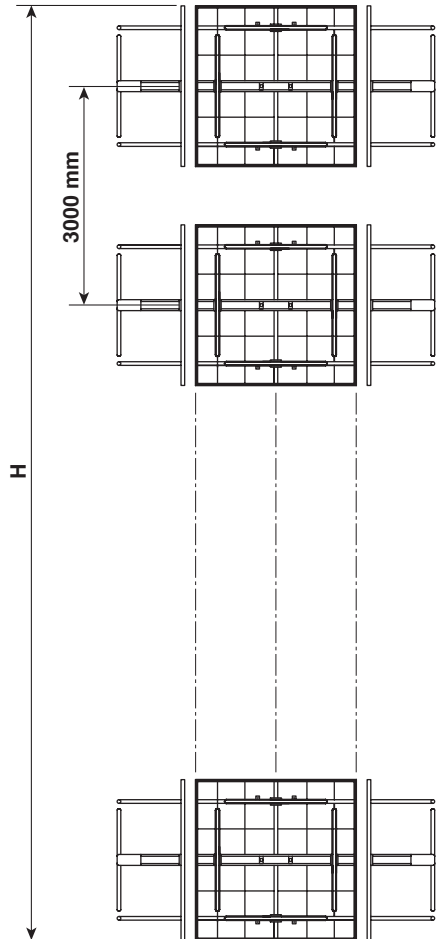

No. of bays	Panels per bay	Gain* (at mid-band)		Weight (without mounting hardware) kg	Antenna height H m	Windload (v = 160 km/h) kN
		dBd	times			
1	2	2.0	1.6	210	2.2	2.7
	3	0.5	1.1	320		4.3
	4	-1.0	0.8	420		5.4
2	2	5.0	3.2	420	5.2	5.4
	3	3.5	2.4	650		8.5
	4	2.0	1.6	850		10.8
4	2	8.0	6.3	850	11.2	10.8
	3	6.5	4.5	1300		17.0
	4	5.0	3.2	1660		21.5
6	2	9.8	9.6	1300	17.2	16.1
	3	8.3	6.8	1870		25.5
	4	6.7	4.7	2540		32.3
8	2	11.0	12.6	1660	23.2	21.5
	3	9.5	8.9	2540		34.0
	4	8.0	6.3	3350		43.0

* Attenuation of the internal cabling and the gain-decrease in case of null fill in the vertical radiation pattern are not considered. Gain figures refer to circularly polarized transmission and linear polarized Rx antenna.

Approximate values for gain decrease:
 cable attenuation: 0.2 – 0.5 dB
 null fill: 0.3 – 1.0 dB

Gain figures are valid for the direction of maximum radiation (see diagrams on following page).

Polarization

H V X

Horizontal Radiation Patterns

Examples of typical horizontal antenna arrays and their **horizontal** radiation patterns for optimal mast dimensions.

Equal power splitting

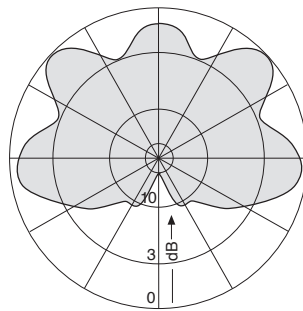
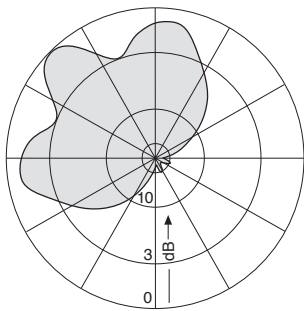
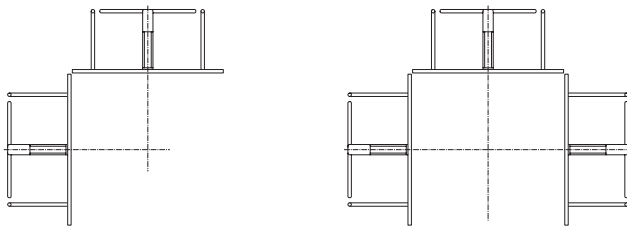

Equal power splitting

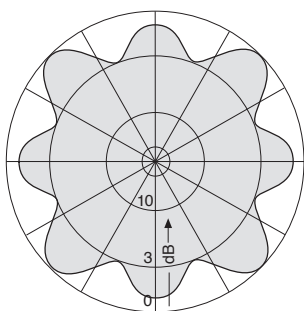
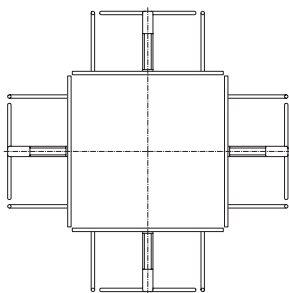

Different power splitting

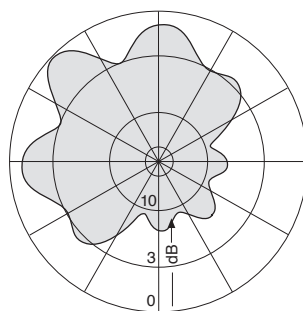
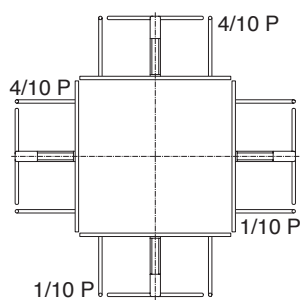

Vertical Radiation Patterns

Examples of typical **vertical** radiation patterns*) for several bays of identical, vertically stacked antenna arrays.

2 bays

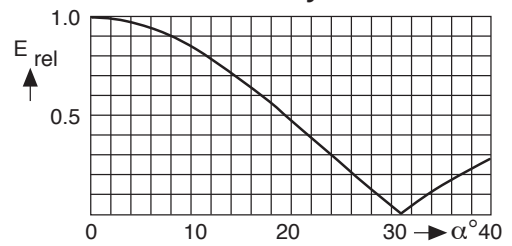

4 bays

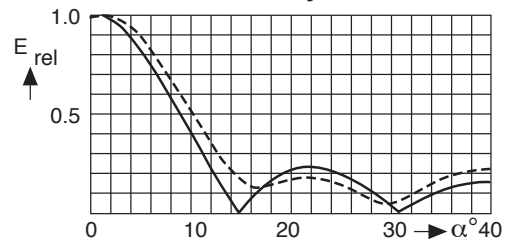

6 bays

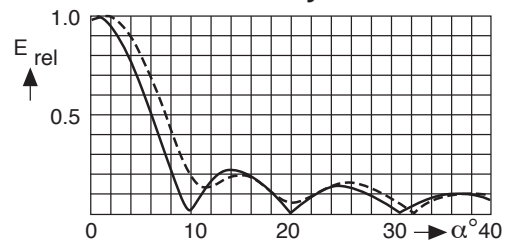

8 bays

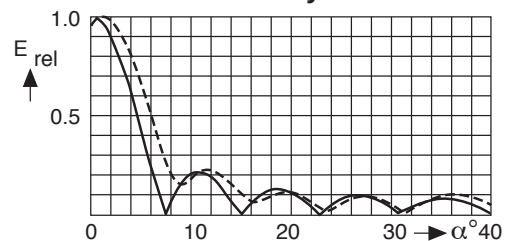

*) ——— without null fill
 - - - - - with null fill and beam tilt

Polarization V

- An economic FM-transmitting antenna system can be built by stacking 2 or more vertical dipoles (page 44) in front of a tubular mast (∅ 60–120 mm).
- Such antenna systems provide signal coverage in all azimuth directions as shown in the horizontal radiation pattern below.

Input	Connectors according to IEC, EIA or DIN.
Max. power	According to customer's requirements.
Frequency	87.5 – 108 MHz
VSWR, typically	< 1.3 throughout the whole frequency range. Lower VSWR for parts of band upon request.
Impedance	50 Ω
Polarization	Vertical
Internal connections	Connectors according to IEC, EIA or DIN are used throughout the system, allowing easy assembly and maintenance.
Vertical radiation pattern	Null fill and beam tilt upon request.
Horizontal radiation pattern	Omnidirectional, with preferred direction.
Half antenna splitting	Upon request, the antenna can be divided into two halves (for emergency operation and maintenance). The two halves are connected by a 2-way power splitter or patch panel.
Pressurization	Splitters and connecting cables can be supplied with dry air (please specify when ordering).
Grounding	Via mounting parts.
Max. wind velocity	240 km/h

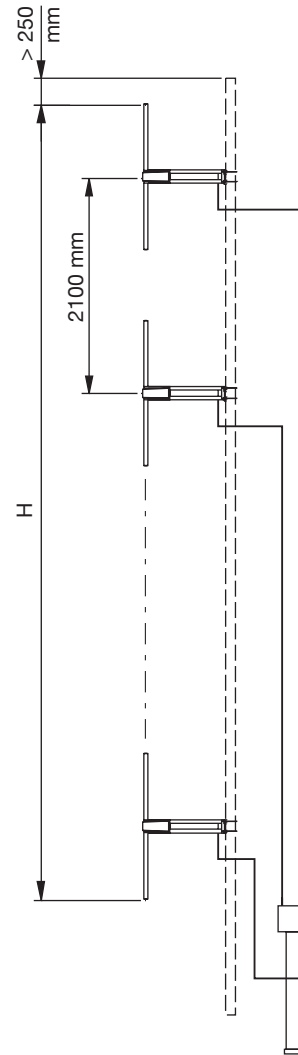

No. of bays	Gain* (at mid-band)		Weight (without mounting hardware) kg	Antenna height H m	Windload (v = 160 km/h)	
	dBd	times			frontal N	lateral N
2	5.0	3.2	40	3.48	230	440
4	8.0	6.3	80	7.68	460	880
6	9.7	9.3	120	11.88	690	1320
8	11.0	12.6	180	16.08	920	1760
10	11.8	15.1	220	20.28	1150	2200
12	12.7	18.6	270	24.48	1380	2640
16	14.0	25.1	350	32.88	1840	3520

* Attenuation of the internal cabling and the gain-decrease in case of null fill in the vertical radiation pattern are not considered.
 Approximate values for gain decrease:
 cable attenuation: 0.2 – 0.5 dB
 null fill: 0.3 – 1.0 dB
 Gain figures are valid for the direction of maximum radiation (see diagrams on following page).

Typical Horizontal Radiation Pattern
(at mid-band)

(Radiators mounted onto a slim steel tube, tower effects not considered)

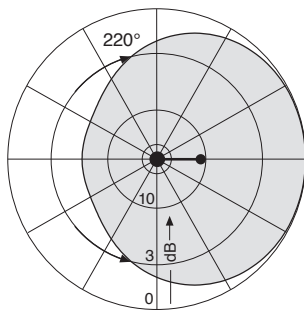

Vertical Radiation Patterns

Examples of typical **vertical** radiation patterns*) for several bays of identical, vertically stacked radiators.

4 bays

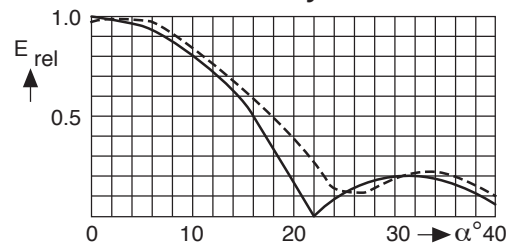

6 bays

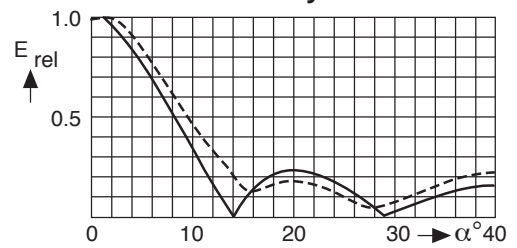

8 bays

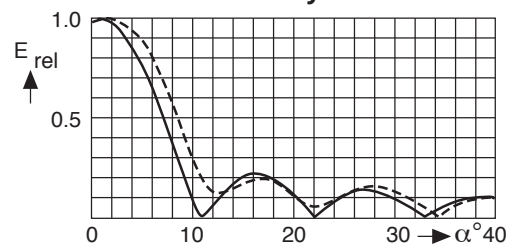

12 bays

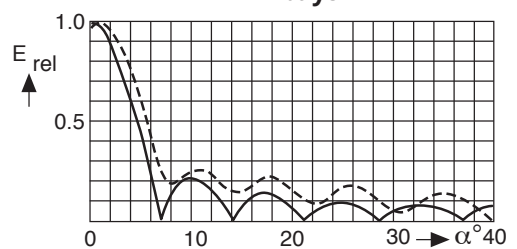

*) ——— without null fill
----- with null fill and beam tilt

Polarization H

- Superturnstile Antenna made of hot-dip galvanized steel for mounting on top of mast.
- Up to 4 bays may be built as self-supporting version. Up to 8 bays can be stacked inside a self-supporting GRP cylinder.

Input	Connectors according to IEC, EIA or DIN.
Max. power	According to customer's requirements, 10 kW max. per bay.
Frequency	87.5–108 MHz
VSWR, typically	< 1.2 throughout the whole frequency range.
Impedance	50 Ω
Polarization	Horizontal
Vertical radiation pattern	Null fill and beam tilt upon request.
Horizontal radiation pattern	Omnidirectional
Half antenna splitting	Upon request, the antenna can be divided into two halves (for emergency operation and maintenance). The two halves are connected by a 2-way power splitter or patch panel.
Internal connections	The radiating elements are fed with coaxial connecting cables and hybrid couplers. Connectors according to IEC, EIA or DIN are used throughout the system, allowing easy assembly and maintenance.
Mounting	On top of existing structure by means of a flange.
Ice protection	The radiating slots are protected by a fiberglass cover. Cylinder provides full protection.
Grounding	Via mounting parts resp. via 4 grounding ropes at the exterior cylinder-surface.
Max. wind velocity	As required.

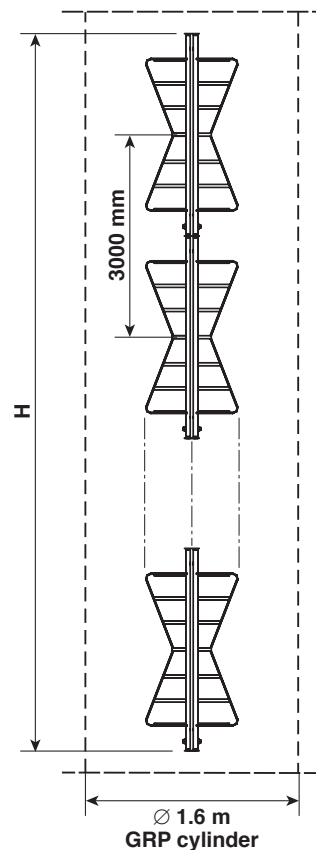

No. of bays	Gain* (at mid-band)		Weight kg		Antenna height H m	Windload** (160 km/h) kN	
	dBd	times	self-supporting version	with cylinder 1.6 m Ø		self-supporting version	with cylinder 1.6 m Ø
1	1	1.26	470	depending	3	3.3	4.0
2	4	2.51	810	on	6	6.5	8.0
4	7	5.00	1450	fiberglass	12	14.0	16.0
8	10	10.00	-	cylinder	24	-	32.0

* Attenuation of the internal cabling and the gain-decrease in case of null fill in the vertical radiation pattern are not considered.

Approximate values for gain decrease:

cable attenuation: 0.2 – 0.4 dB

null fill: 0.3 – 1.0 dB

Gain figures are valid for the direction of maximum radiation (see diagrams on following page).

** Only according to antenna aperture H without base flange and top.

Typical Horizontal Radiation Pattern
(at mid-band)

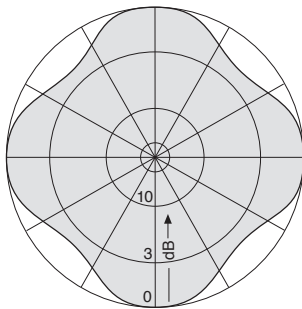

Vertical Radiation Patterns

Examples of typical **vertical** radiation patterns*) for several bays of identical, vertically stacked superturnstile.

2 bays

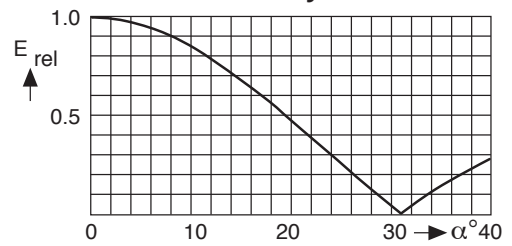

4 bays

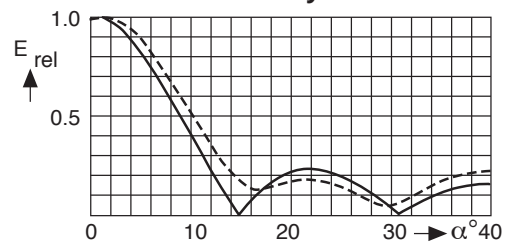

6 bays

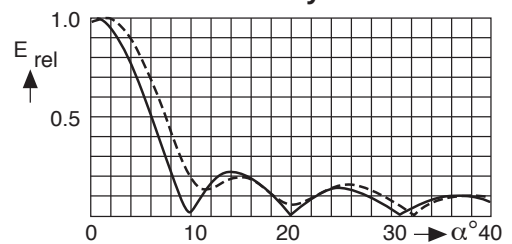

8 bays

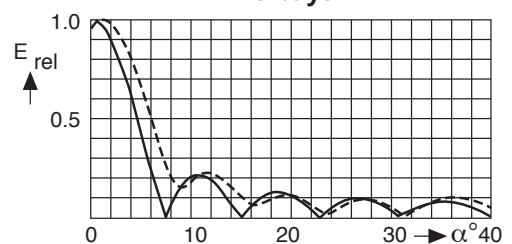

*) ——— without null fill
 - - - - - with null fill and beam tilt

Polarization H

- Antenna array of Log.-Per. Antenna (page 49) for different radiation patterns.
- High-power FM Antenna System with very low wind load.
- The feeder network is made up of coaxial power splitters and flexible connecting cables in accordance with the radiation patterns specification and the transmitter power.

Input	Connectors according to IEC, EIA or DIN.
Max. power	According to customer's requirements.
Frequency	87.5 - 108 MHz
VSWR, typically	< 1.2 throughout the whole frequency range.* Lower VSWR for parts of band upon request.
Impedance	50 Ω
Polarization	Horizontal
Internal connections	Connectors according to IEC, EIA or DIN are used throughout the system, allowing easy assembly and maintenance.
Vertical radiation pattern	Null fill and beam tilt upon request.
Horizontal radiation pattern	Omnidirectional, directional or custom-designed.
Half antenna splitting	Upon request, the antenna can be divided into two halves (for emergency operation and maintenance). The two halves are connected by a 2-way power splitter or patch panel.
Pressurization	Splitters and connecting cables can be supplied with dry air (please specify when ordering).
Grounding	Via mounting parts.
Max. wind velocity	225 km/h

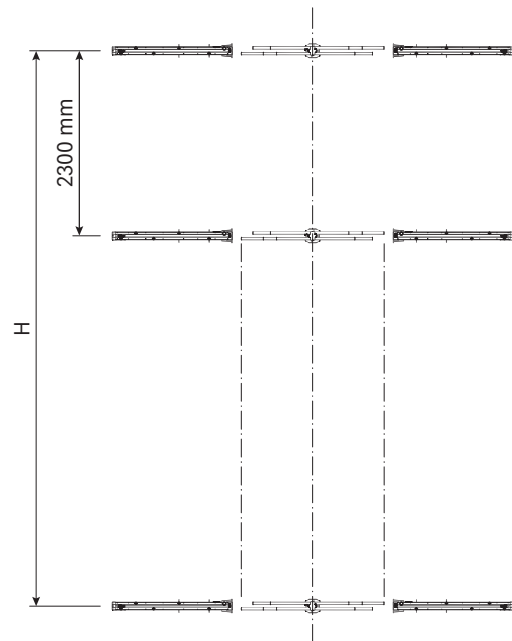

* It is recommended to use decoupling rods, Type 7530000004 or similar, between the bays of the system, to ensure a proper VSWR over the complete band.

No. of bays	Log.-Per. per bay	Gain*		Weight (without mounting hardware) kg	Antenna height H m	Windload (v = 160 km/h) kN
		(at mid-band) dBd	times			
2	2	7.0	5.0	160	2.5	1.3
	3	5.4	3.5	230		1.9
	4	4.2	2.6	300		2.5
4	2	10.0	10.0	300	7.1	2.5
	3	8.5	7.1	440		3.8
	4	7.2	5.3	680		5.0
8	2	13.1	20.4	680	16.3	5.0
	3	11.5	14.1	960		7.6
	4	10.3	10.7	1240		10.0
10	2	14.0	25.1	830	20.9	6.3
	3	12.5	17.8	1180		9.5
	4	11.2	13.2	1530		12.5
12	2	14.8	30.2	970	25.5	7.5
	3	13.3	21.4	1390		11.4
	4	12.0	15.9	1810		15.0

* Attenuation of the internal cabling and the gain-decrease in case of null fill in the vertical radiation pattern are not considered.
 Approximate values for gain decrease:
 cable attenuation: 0.2 - 0.5 dB
 null fill: 0.3 - 1.0 dB
 Gain figures are valid for the direction of maximum radiation (see diagrams on following page).

Horizontal Radiation Patterns

Examples of typical horizontal antenna arrays and their **horizontal** radiation patterns for optimal mast dimensions.

Equal power splitting

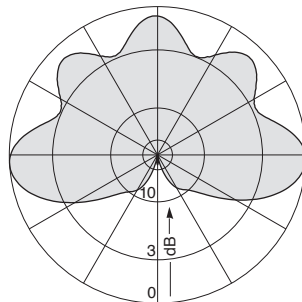
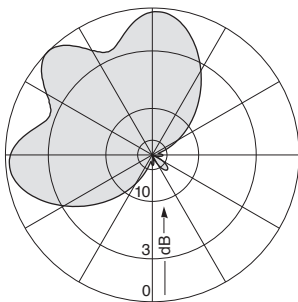
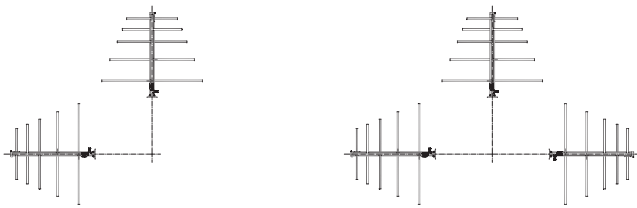

Equal power splitting

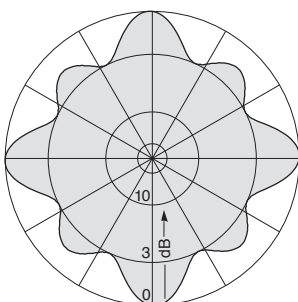
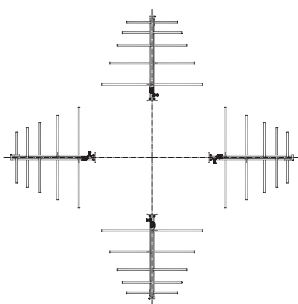

Different power splitting

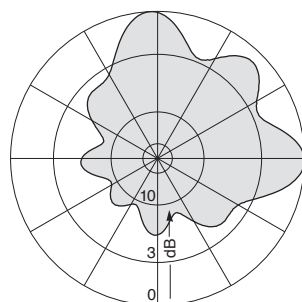
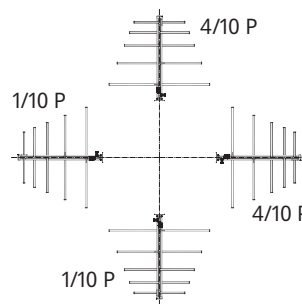

Vertical Radiation Patterns

Examples of typical **vertical** radiation patterns*) for several bays of identical, vertically stacked antenna arrays.

2 bays

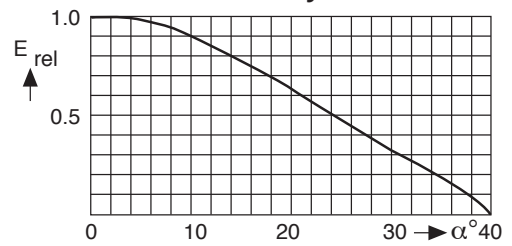

4 bays

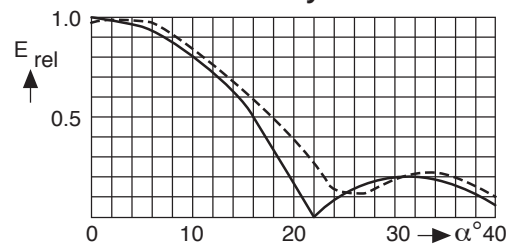

8 bays

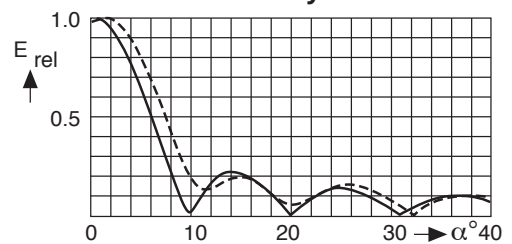

10 bays

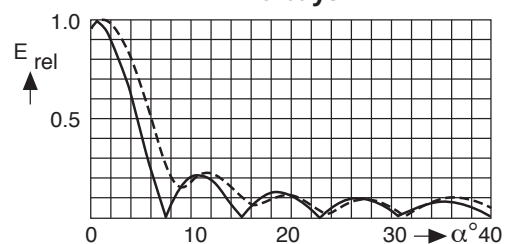

*) ——— without null fill
 - - - - - with null fill and beam tilt

Systems 87.5-108 MHz

Antennas for FM in VHF Band 87.5–108 MHz

Polarization

H

V

- Especially suitable for square masts.

Order No.	601278 K5231187	601629 K5231188	715849
Input	7-16 female	7/8" EIA flange	13-30 female
Max. power	3 kW	5 kW	7 kW
Frequency range	87.5 - 108 MHz		
VSWR	< 1.15		
Gain (at mid-band)	7.5 dBd		
Impedance	50 Ω		
Polarization	Horizontal or vertical		
Weight	64 kg		
Wind load (at 160 km/h)	Frontal / lateral: 1500 N / 875 N		
Horizontally polarized	Frontal / lateral: 1500 N / 825 N		
Vertically polarized			
Max. wind velocity	240 km/h		

- Material: Hot-dip galvanized steel.
Radome: Fiberglass.
- Mounting: Mounting hardware and mounting dimensions upon request.
- Grounding: Via mounting parts.
- Ice protection: Even under severe icy conditions the antenna is still functional due to its heavy-duty construction and the fiberglass covers for the feeding points.
- Scope of supply: Antenna without mounting clamps.
- Special features: The antenna is shipped dismounted.

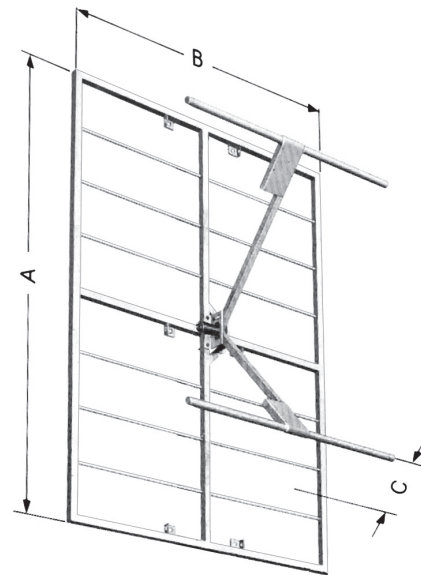

A: ~ 2490 mm
B: ~ 1740 mm
C: ~ 730 mm

Radiation Patterns (at mid-band)

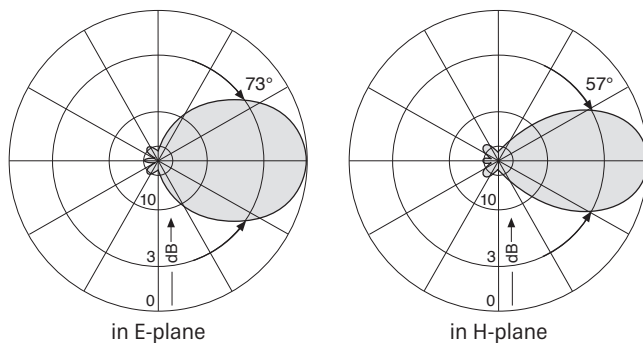

- Especially suitable for triangular and round masts.

Order No.	601694 K523417	75010008	752183
Input	7-16 female	7/8" EIA flange	13-30 female
Max. power	3 kW	5 kW	7 kW
Frequency range	87.5 - 108 MHz		
VSWR	< 1.2		
Gain (at mid-band)	7 dBd		
Impedance	50 Ω		
Polarization	Horizontal		
Weight	66 kg		
Wind load (at 160 km/h)	Frontal: 1700 N Lateral: 875 N		
Max. wind velocity	240 km/h		

- Material: Hot-dip galvanized steel.
Radome: Fiberglass.
- Mounting: Mounting hardware and mounting dimensions upon request.
- Grounding: Via mounting parts.
- Ice protection: Even under severe icy conditions the antenna is still functional due to its heavy-duty construction and the fiberglass covers for the feeding points.
- Scope of supply: Antenna without mounting clamps.
- Special features: The antenna is shipped dismounted.

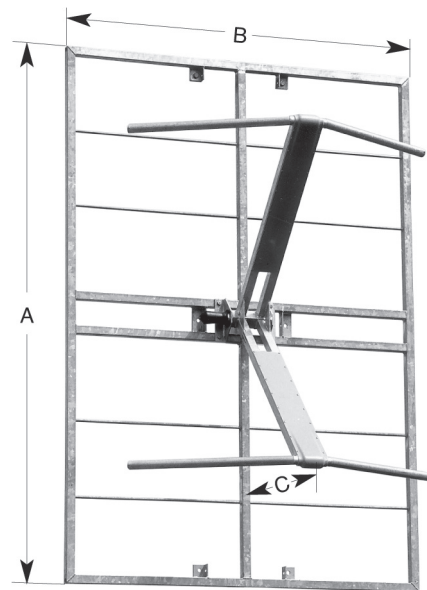

A: ~ 2490 mm
B: ~ 1740 mm
C: ~ 850 mm

Antennas
87.5-108 MHz

Radiation Patterns (at mid-band)

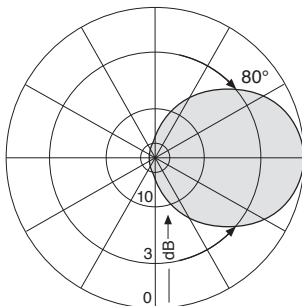

Horizontal Radiation Pattern

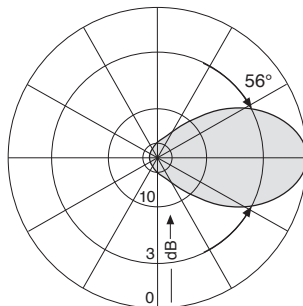

Vertical Radiation Pattern

- Especially suitable for triangular and round masts.

Order No.	772500	772501
Input	7-16 female	7/8" EIA flange
Max. power	3 kW	5 kW
Frequency range	87.5 - 108 MHz	
VSWR	< 1.15	
Gain (at mid-band)	6 dBd	
Impedance	50 Ω	
Polarization	Vertical	
Weight	65 kg	
Wind load (at 160 km/h)	Frontal: 1550 N	Lateral: 850 N
Max. wind velocity	240 km/h	

- Material:** Hot-dip galvanized steel.
Radome: Fiberglass.
- Mounting:** To a vertical pipe of \varnothing 89 mm by 3 pcs. U-bolts (supplied) or to proper flanges.
Mounting dimensions upon request.
- Grounding:** Via mounting parts.
- Ice protection:** Even under icy conditions the antenna keeps operating due to the radomes covering the feed areas.
- Scope of supply:** Antenna consisting of two half-wave dipoles with reflector screen and 3 U-bolts.
- Special features:** The antenna is shipped dismounted.

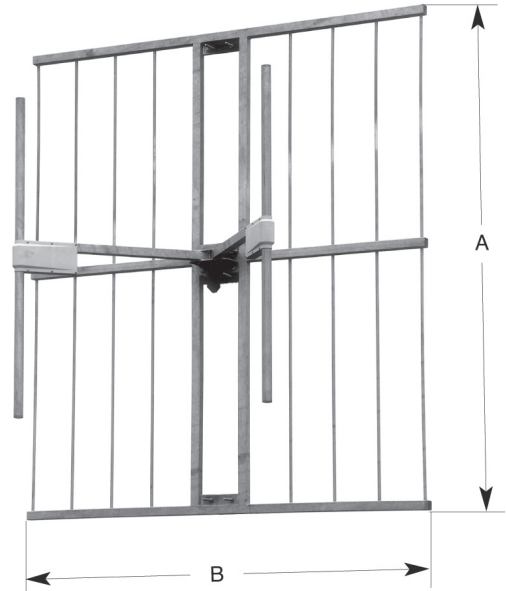

A: ~ 2200 mm
B: ~ 2000 mm

Radiation Patterns (at mid-band)

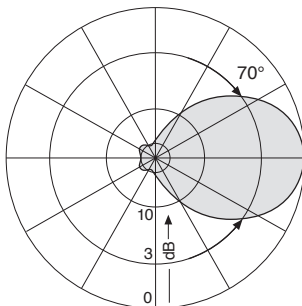

Horizontal Radiation Pattern

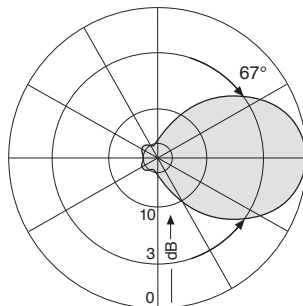

Vertical Radiation Pattern

Polarization

H V X

- Optionally for circular, horizontal, vertical or slant polarization.
- Especially suitable for square masts.

Order No.	601768 K5332187	601979 K5332188
Input	4 x 7-16 female	4 x 7/8" EIA flange
Max. power	3 kW per input	4 kW per input
Frequency range	87.5 – 108 MHz	
VSWR	< 1.25 (linear polarization) < 1.1 (circular polarization)	
Gain (at mid-band)	7.5 dBd (linear polarization) 4.5 dBd (circular polarization)	
Impedance	50 Ω	
Polarization	Horizontal, vertical, circular	
Weight	89 kg	
Wind load (at 160 km/h)	Frontal: 1600 N Lateral: 1130 N	
Max. wind velocity	240 km/h	

4 dipoles are arranged symmetrically in front of a reflector screen. With suitable feeding the antenna radiates circularly polarized. An isolation of 40–50 dB between horizontal and vertical pairs of dipoles is achieved through the special design. This design allows the transmission of 2 programs – horizontally and vertically polarized – independently from each other.

- Material:** Hot-dip galvanized steel.
Weather protection: fiberglass cover.
- Mounting:** The antenna must be mounted so that the bent radiators are horizontally polarized. Mounting dimensions and mounting hardware on request.
- Grounding:** Via mounting parts.
- Ice protection:** Even under severe icy conditions the antenna is still functional due to its heavy-duty construction and the fiberglass covers for the feeding points.
- Scope of supply:** Antenna without mounting clamps.
- Special features:** The antenna is shipped dismounted.
- Polarization:** Suitable feeding of the horizontal and vertical dipole pairs optionally result in left or right hand circular or elliptical or slant polarization or simultaneous horizontal and vertical polarization.

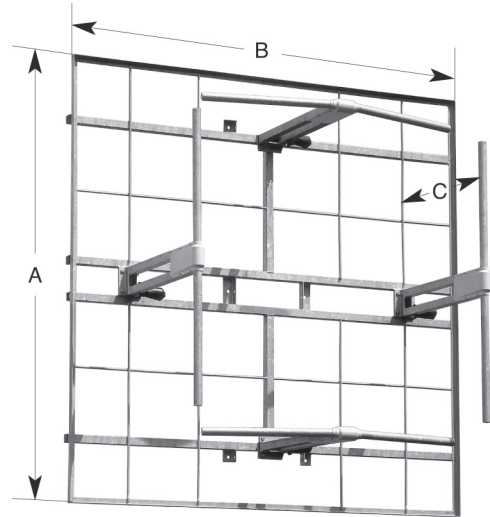

A = B: ~ 2200 mm
C: ~ 830 mm

Antennas
87.5–108 MHz

Radiation Patterns (at mid-band)

Horizontal Polarization (bent dipoles)

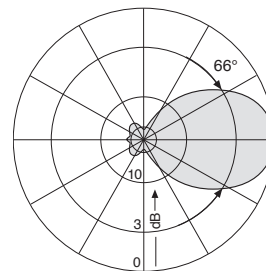

in E-plane
Horizontal Radiation Pattern

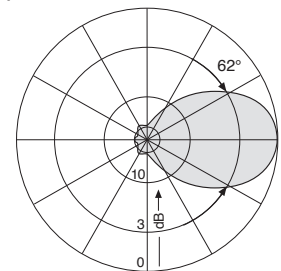

in H-plane
Vertical Radiation Pattern

Vertical Polarization (straight dipoles)

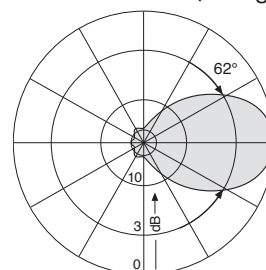

in H-plane
Horizontal Radiation Pattern

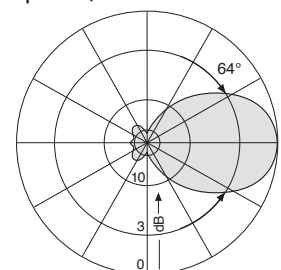

in E-plane
Vertical Radiation Pattern

Dipole Antenna

87.5-108 MHz

KATHREIN

Polarization

V

- Quasi-omnidirectional radiation pattern.
- For tubular masts.

Order No.	762943	763715	775130
Input	7-16 female	7/8" EIA flange	1 1/2" EIA flange
Max. power	3 kW	5 kW	10 kW
Frequency range	87.5 - 108 MHz		
VSWR	< 1.3		< 1.25
Gain (at mid-band)	2 dBd		
Impedance	50 Ω		
Polarization	Vertical		
Weight	13 kg		22 kg
Wind load (at 160 km/h)	Frontal: 115 N Lateral: 220 N		165 N 340 N
Max. wind velocity	240 km/h		300 km/h

Material: Hot-dip galvanized steel.

Mounting: To pipes of 60-125 mm by means of 2 mounting clamps, supplied.

Grounding: Via mounting parts.

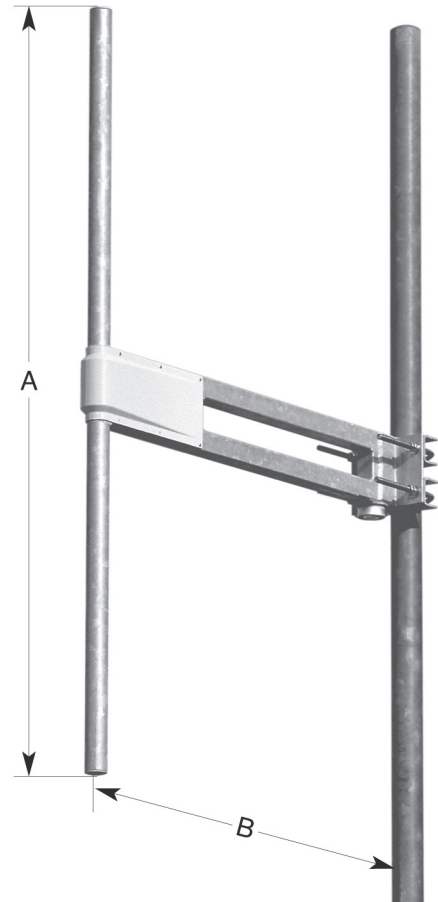

A: ~ 1380 mm
B: ~ 830 mm

Radiation Patterns (at mid-band)

(Radiator mounted onto a slim steel tube, tower effects not considered)

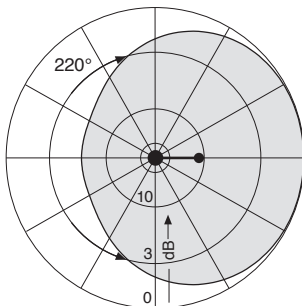

Horizontal Radiation Pattern

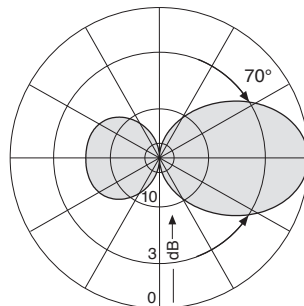

Vertical Radiation Pattern

- 3 element broadband Yagi antenna.

Order No.	77077	77076
Input	7-16 female	7/8" EIA flange
Max. power	3 kW	5 kW
Frequency range	87.5 - 108 MHz	
VSWR	< 1.3	
Gain (at mid-band)	4 dBd	
Impedance	50 Ω	
Polarization	Vertical	
Weight	13 kg	
Wind load (at 160 km/h)	Frontal: 165 N	Lateral: 275 N
Max. wind velocity	225 km/h	

Material: Hot-dip galvanized steel.

Mounting: To pipes of 60-125 mm \varnothing by means of 2 U-bolts, supplied.

Grounding: Via mounting parts.

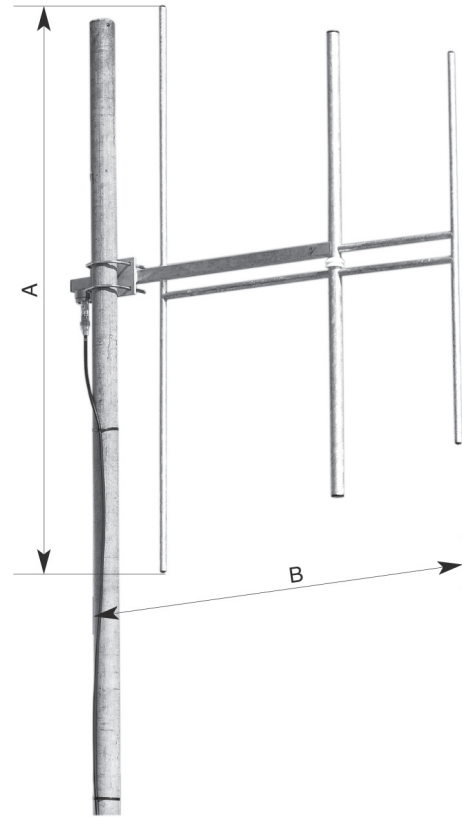

A: ~ 1822 mm
B: ~ 1300 mm

Antennas
87.5-108 MHz

Radiation Patterns (at mid-band)

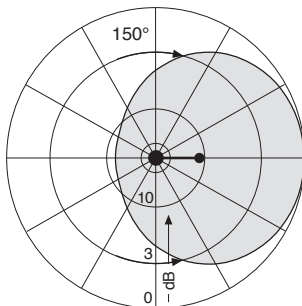

Horizontal Radiation Pattern

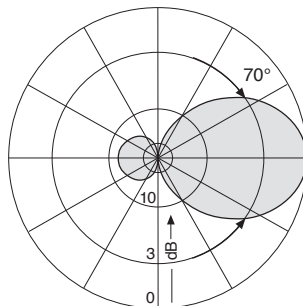

Vertical Radiation Pattern

Yagi Antenna

87.5-108 MHz

KATHREIN

Polarization

V

- 4 element broadband Yagi antenna.

Order No.	775838	775738
Input	7-16 female	7/8" EIA flange
Max. power	3 kW	5 kW
Frequency range	87.5 - 108 MHz	
VSWR	< 1.3	
Gain (at mid-band)	5 dBd	
Impedance	50 Ω	
Polarization	Vertical	
Weight	20 kg	
Wind load (at 160 km/h)	Frontal: 200 N	Lateral: 390 N
Max. wind velocity	225 km/h	

Material: Hot-dip galvanized steel.

Mounting: To pipes of 60-125 mm \varnothing by means of 2 U-bolts, supplied.

Grounding: Via mounting parts.

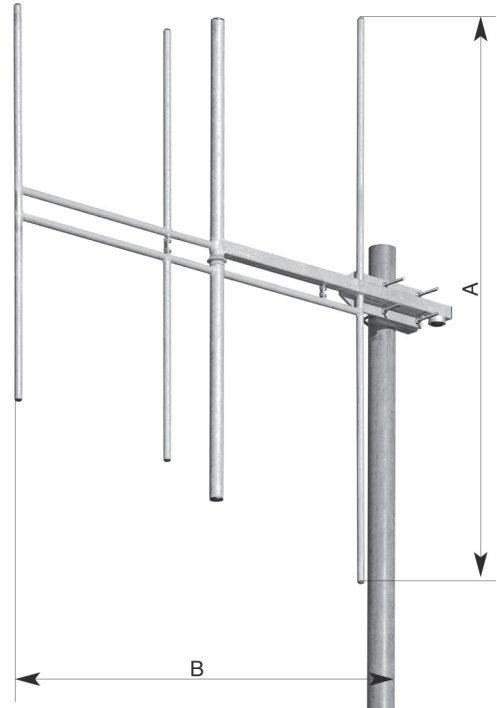

A: ~ 1750 mm
B: ~ 1600 mm

Radiation Patterns (at mid-band)

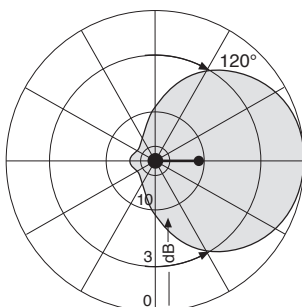

Horizontal Radiation Pattern

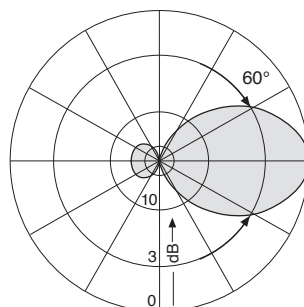

Vertical Radiation Pattern

Polarization

H

V

- 4 element broadband Yagi antenna.
- Component for low power transmitting antennas.

Order No.	600263 K524017
Input	7-16 female
Max. power	500 W
Frequency range	87.5 – 108 MHz
VSWR	< 1.3
Gain (at mid-band)	5.5 dBd
Impedance	50 Ω
Polarization	Horizontal or vertical
Weight	13.5 kg
Wind load (at 160 km/h)	
Horizontally polarized	Frontal / lateral: 215 N / 160 N
Vertically polarized	Frontal / lateral: 215 N / 340 N
Max. wind velocity	225 km/h

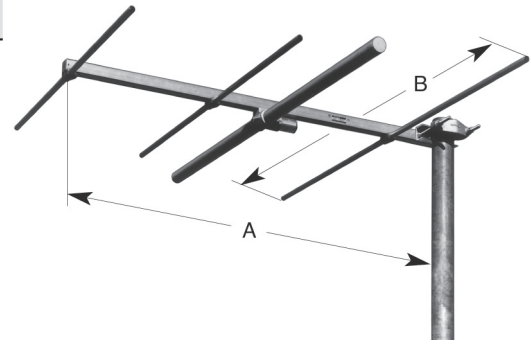

A: ~ 1400 mm
B: ~ 1700 mm

Antennas
87.5–108 MHz

Material: Supporting pipe: Hot-dip galvanized steel. Director pipe and reflector: Weather-proof aluminum. Radiator in fiberglass radome.

Mounting: To pipes of 60–115 mm diameter by means of mounting clamps, supplied.

Grounding: Via mounting parts.

Special features: The antenna is shipped dismounted.

Radiation Patterns (at mid-band)

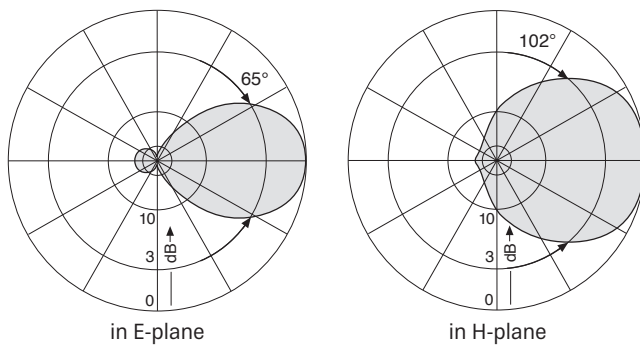

Polarization

H

- Logarithmic-periodic broadband directional antenna with extremely low side-lobes.
- High reliability even under heavy icy conditions.

Order No.	600232 K522217
Input	7-16 female
Max. power	2.5 kW
Frequency range	87.5 - 108 MHz
VSWR	< 1.3
Gain (at mid-band)	6 dBd
Impedance	50 Ω
Polarization	Horizontal
Weight	46 kg
Wind load (at 160 km/h)	Frontal: 500 N Lateral: 875 N
Max. wind velocity	225 km/h
Side-lobe suppression	> 25 dB

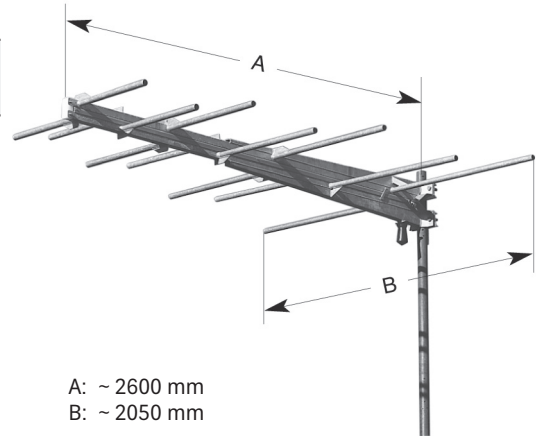

Material: Hot-dip galvanized steel.

Mounting: To pipes of 60-115 mm diameter by means of mounting clamps, supplied.
Attention: Antenna may not be installed with vertical polarization.
Special version for vertical polarization upon request.

Grounding: Via mounting parts.

Radiation Patterns (at mid-band)

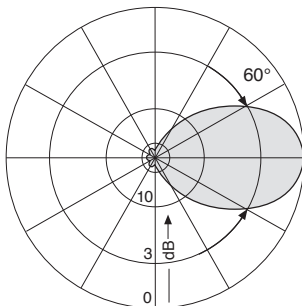

Horizontal Radiation Pattern

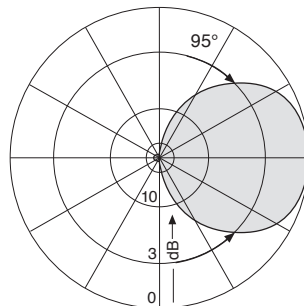

Vertical Radiation Pattern

Polarization

H **V**

- Logarithmic-periodic broadband directional antenna.
- Suitable for sites with icing.

Order No.	75010285	75010286	75010287
Input	7-16 female	7/8" EIA flange	1 1/2" EIA flange
Max. power	3 kW	5 kW	7 kW
Frequency range	87.5 - 108 MHz		
VSWR	< 1.2		
Gain (at mid-band)	5 dBd		
Impedance	50 Ω		
Polarization	Horizontal or vertical		
Weight	29 kg		
Wind load (at 160 km/h)	Frontal / lateral: 300 N / 325 N		
Horizontally polarized	Frontal / lateral: 300 N / 475 N		
Vertically polarized			
Max. wind velocity	225 km/h		

Material: Hot-dip galvanized steel.
 Mounting: To pipes of 60-120 mm diameter by means of mounting clamps, supplied.
 Grounding: Via mounting parts.

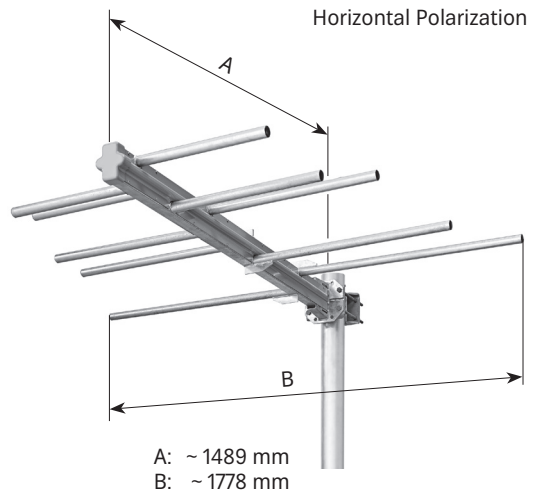

Radiation Patterns (at mid-band)

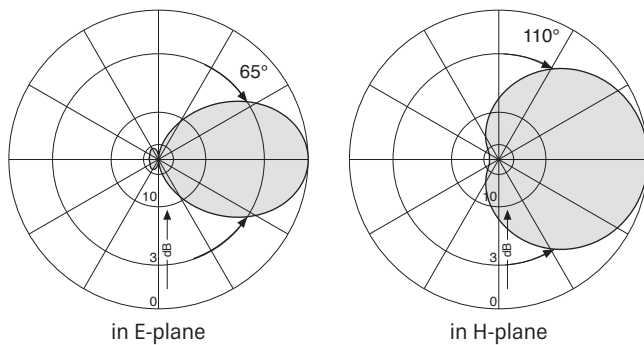

Antennas
87.5-108 MHz



Antenna Systems 174-240 MHz

Broadcast Station "Heidelberg", Germany



Polarization H

- Antenna array of dipole panels (page 64) for different radiation patterns.
- Especially suitable for mounting on square masts.
- The feeder network is made up of coaxial power splitters and flexible connecting cables in accordance with the radiation patterns specification and the transmitter power.

Input	Connectors according to IEC, EIA or DIN.
Max. power	According to customer's requirements.
Frequency	174 – 230 MHz
VSWR, typically	< 1.05 in the operating channel after tuning or < 1.1 in the whole range.
Impedance	50 Ω
Polarization	Horizontal
Internal connections	Connectors according to IEC, EIA or DIN are used throughout the system, allowing easy assembly and maintenance.
Vertical radiation pattern	Null fill and beam tilt upon request.
Horizontal radiation pattern	Omnidirectional, directional or custom-designed.
Half antenna splitting	Upon request, the antenna can be divided into two halves (for emergency operation and maintenance). The two halves are connected by a 2-way power splitter or patch panel.
Pressurization	Splitters and connecting cables can be supplied with dry air (please specify when ordering).
Grounding	Via mounting parts.
Max. wind velocity	240 km/h

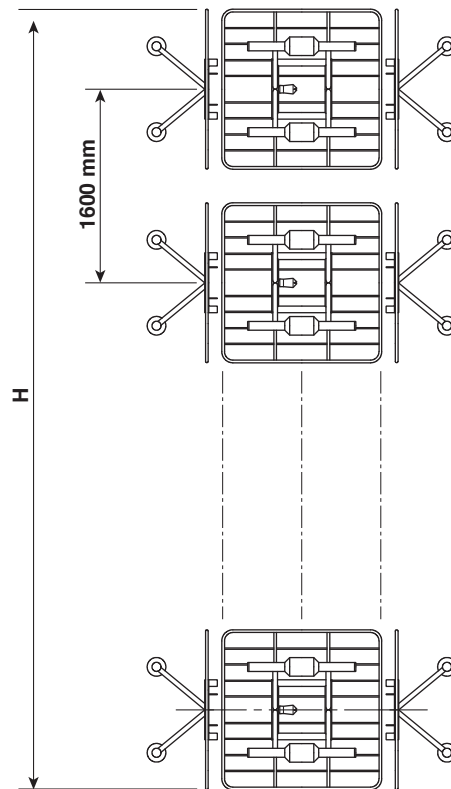

No. of bays	Panels per bay	Gain* (at mid-band)		Weight (without mounting hardware) kg	Antenna height H m	Windload (v = 160 km/h) kN
		dBd	times			
1	2	5.5	3.5	66	1.3	1.1
	3	4.3	2.7	94		1.8
	4	3.1	2.0	122		2.1
2	2	8.5	7.1	122	2.9	2.1
	3	7.3	5.4	173		3.6
	4	6.1	4.1	224		4.3
4	2	11.5	14.1	224	6.1	4.3
	3	10.3	10.7	346		7.3
	4	9.1	8.1	453		8.5

* Attenuation of the internal cabling and the gain-decrease in case of null fill in the vertical radiation pattern are not considered.
 Approximate values for gain decrease:
 cable attenuation: 0.2 – 0.4 dB
 null fill: 0.2 – 0.5 dB
 Gain figures are valid for the direction of maximum radiation (see diagrams on following page).

Horizontal Radiation Patterns

Examples of typical horizontal antenna arrays and their **horizontal** radiation patterns for optimal mast dimensions.

Equal power splitting

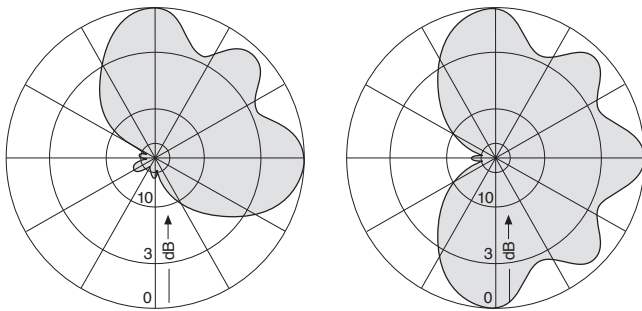
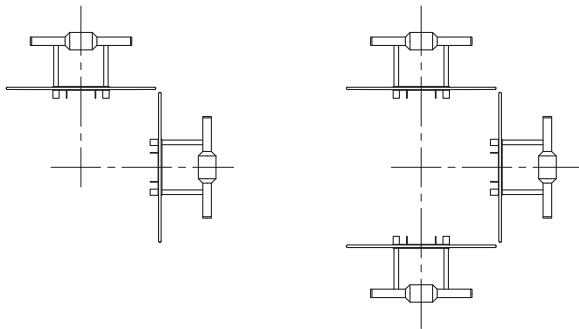

Equal power splitting

Different power splitting

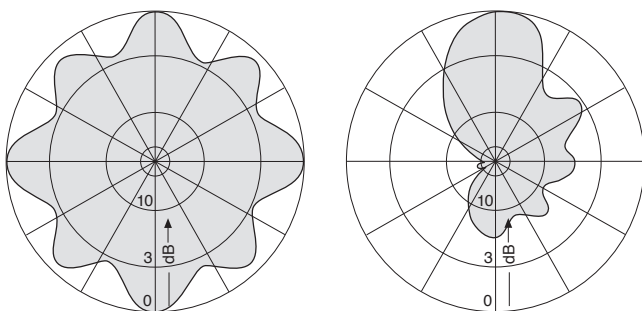
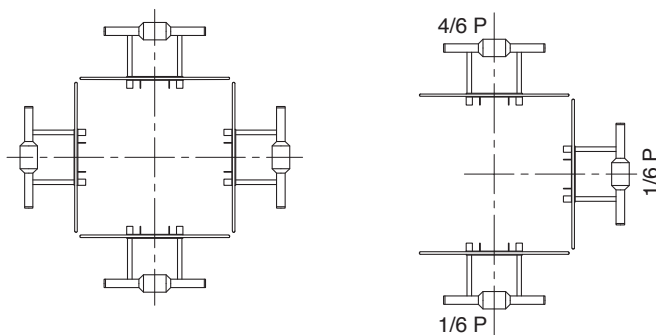

Vertical Radiation Patterns

Examples of typical **vertical** radiation patterns*) for several bays of identical, vertically stacked antenna arrays.

2 bays

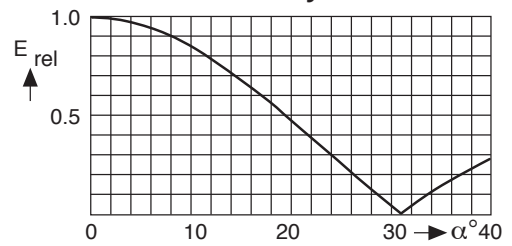

4 bays

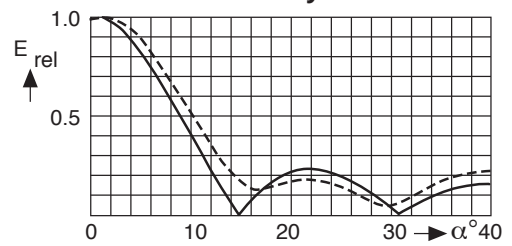

6 bays

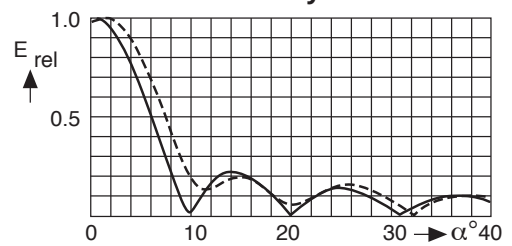

8 bays

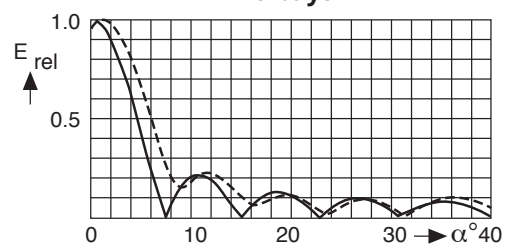

*) ——— without null fill
 - - - - - with null fill and beam tilt

Polarization V

- Antenna array of dipole panels (page 65) for different radiation patterns.
- Especially suitable for mounting on square masts.
- The feeder network is made up of coaxial power splitters and flexible connecting cables in accordance with the radiation patterns specification and the transmitter power.

Input	Connectors according to IEC, EIA or DIN.
Max. power	According to customer's requirements.
Frequency	174 – 240 MHz
VSWR, typically	< 1.15 in the whole range.
Impedance	50 Ω
Polarization	Vertical
Internal connections	Connectors according to IEC, EIA or DIN are used throughout the system, allowing easy assembly and maintenance.
Vertical radiation pattern	Null fill and beam tilt upon request.
Horizontal radiation pattern	Omnidirectional, directional or custom-designed.
Half antenna splitting	Upon request, the antenna can be divided into two halves (for emergency operation and maintenance). The two halves are connected by a 2-way power splitter or patch panel.
Pressurization	Splitters and connecting cables can be supplied with dry air (please specify when ordering).
Grounding	Via mounting parts.
Max. wind velocity	240 km/h

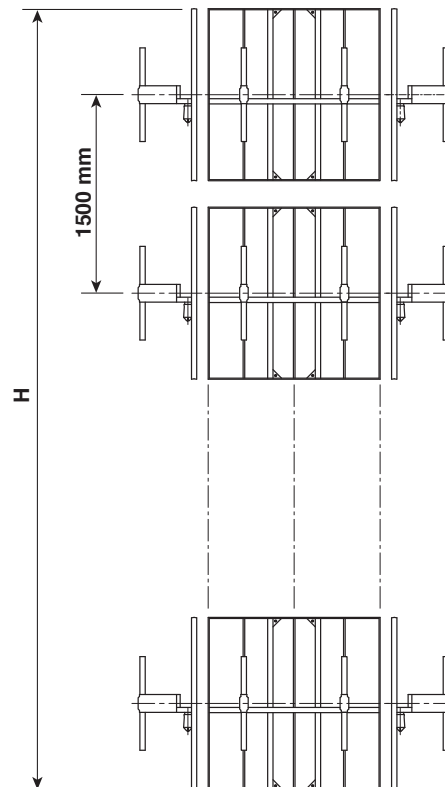

No. of bays	Panels per bay	Gain*		Weight (without mounting hardware) kg	Antenna height H m	Windload (v = 160 km/h) kN
		(at mid-band) dBd	times			
1	2	4.5	2.8	80	1.3	1.2
	3	2.7	1.9	120		1.9
	4	1.9	1.5	160		2.4
2	2	7.5	5.6	160	2.7	2.4
	3	5.7	3.7	240		3.8
	4	4.9	3.1	320		4.8
4	2	10.5	11.2	320	5.5	4.8
	3	8.7	7.4	490		7.5
	4	7.9	6.2	650		9.5

* Attenuation of the internal cabling and the gain-decrease in case of null fill in the vertical radiation pattern are not considered.
 Approximate values for gain decrease:
 cable attenuation: 0.2 – 0.4 dB
 null fill: 0.2 – 0.5 dB
 Gain figures are valid for the direction of maximum radiation (see diagrams on following page).

Polarization

V

Horizontal Radiation Patterns

Examples of typical horizontal antenna arrays and their **horizontal** radiation patterns for optimal mast dimensions.

Equal power splitting

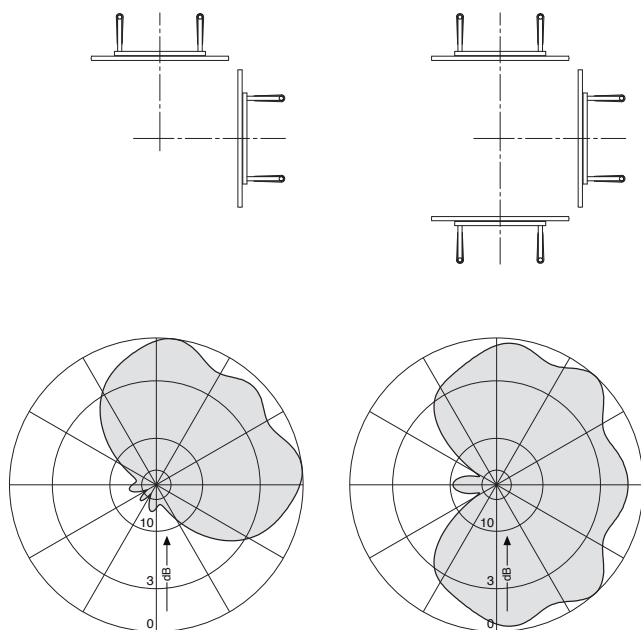

Equal power splitting

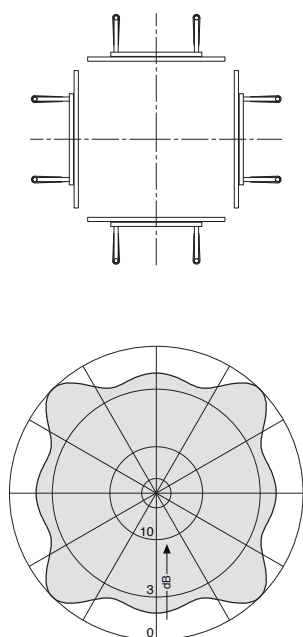

Vertical Radiation Patterns

Examples of typical **vertical** radiation patterns*) for several bays of identical, vertically stacked antenna arrays.

2 bays

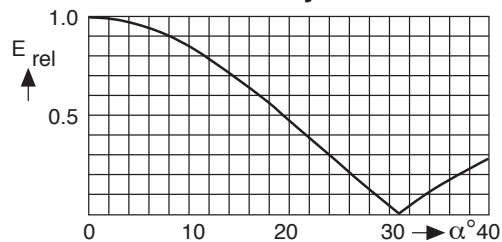

4 bays

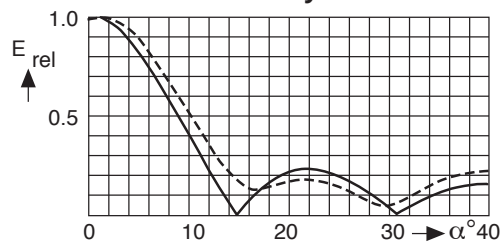

6 bays

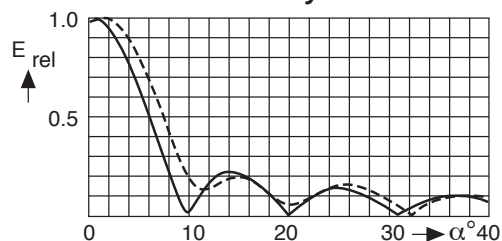

8 bays

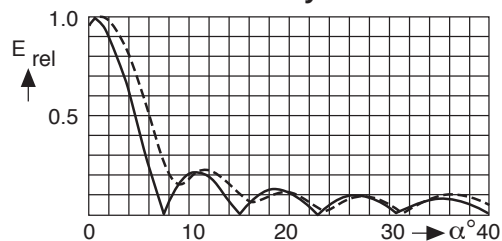

*) ——— without null fill
 - - - - - with null fill and beam tilt

Polarization H

- Antenna array of dipole panels (page 66) for different radiation patterns.
- Especially suitable for mounting on triangular or round masts.
- The feeder network is made up of coaxial power splitters and flexible connecting cables in accordance with the radiation patterns specification and the transmitter power.

Input	Connectors according to IEC, EIA or DIN.
Max. power	According to customer's requirements.
Frequency	174 – 202 MHz resp. 202 – 230 MHz
VSWR, typically	< 1.05 in the operating channels after tuning.
Impedance	50 Ω
Polarization	Horizontal
Internal connections	Connectors according to IEC, EIA or DIN are used throughout the system, allowing easy assembly and maintenance.
Vertical radiation pattern	Null fill and beam tilt upon request.
Horizontal radiation pattern	Omnidirectional, directional or custom-designed.
Half antenna splitting	Upon request, the antenna can be divided into two halves (for emergency operation and maintenance). The two halves are connected by a 2-way power splitter or patch panel.
Pressurization	Splitters and connecting cables can be supplied with dry air (please specify when ordering).
Grounding	Via mounting parts.
Max. wind velocity	240 km/h

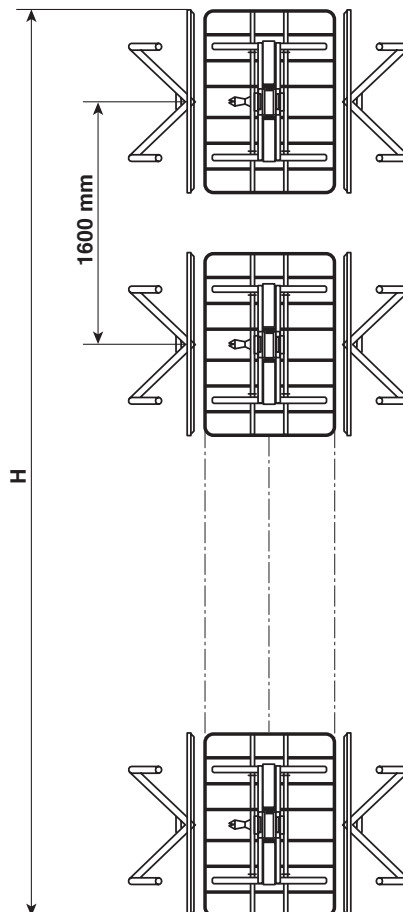

No. of bays	Panels per bay	Gain* (at mid-band)		Weight (without mounting hardware) kg	Antenna height H m	Windload (v = 160 km/h) kN
		dBd	times			
1	2	3.9	2.5	50	1.2	0.8
	3	1.7	1.5	70		1.2
2	2	6.9	4.9	95	2.8	1.7
	3	4.7	3.0	140		2.4
4	2	9.9	9.8	180	6.0	3.3
	3	7.7	5.9	270		4.8
6	2	11.7	14.8	270	9.2	5.0
	3	9.5	8.9	400		7.2
8	2	12.9	19.5	360	12.4	6.6
	3	10.7	11.7	540		9.6

* Attenuation of the internal cabling and the gain-decrease in case of null fill in the vertical radiation pattern are not considered.
 Approximate values for gain decrease:
 cable attenuation: 0.2 – 0.5 dB
 null fill: 0.3 – 1.0 dB
 Gain figures are valid for the direction of maximum radiation (see diagrams on following page).

Polarization

H

Horizontal Radiation Patterns

Examples of typical horizontal antenna arrays and their **horizontal** radiation patterns for optimal mast dimensions.

Equal power splitting

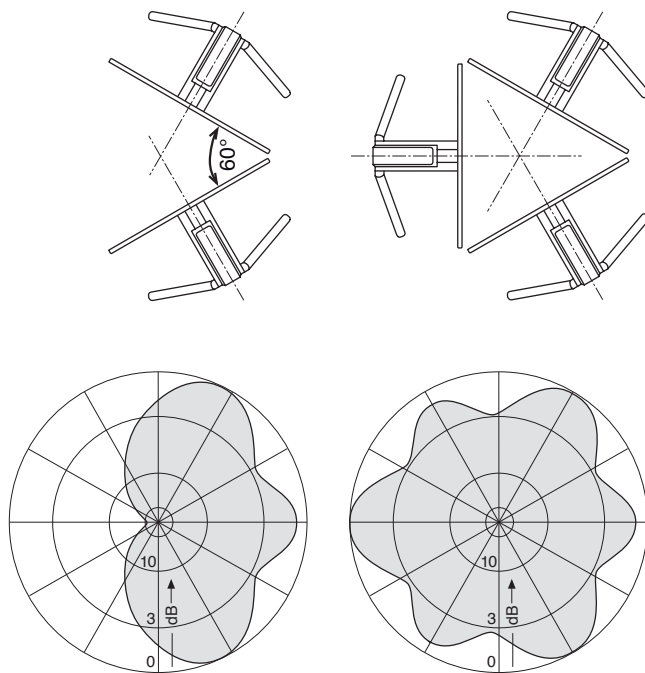

Different power splitting

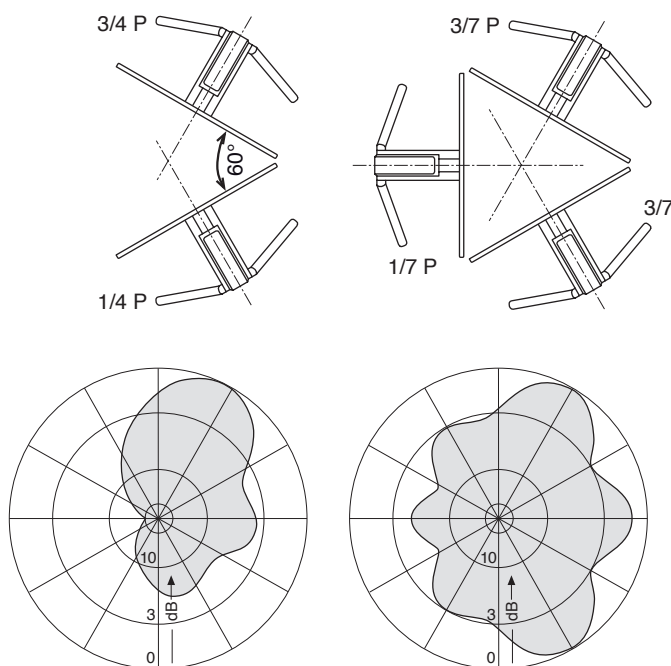

Vertical Radiation Patterns

Examples of typical **vertical** radiation patterns*) for several bays of identical, vertically stacked antenna arrays.

2 bays

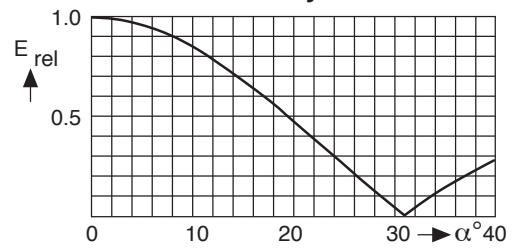

4 bays

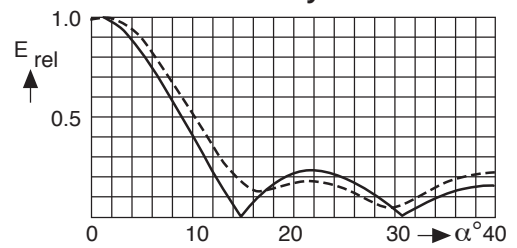

6 bays

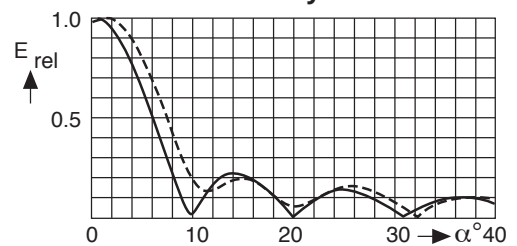

8 bays

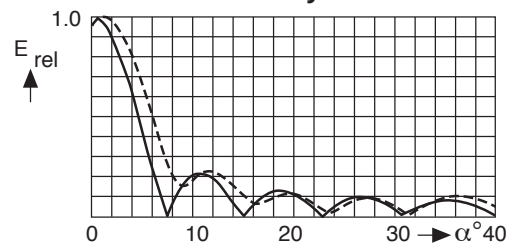

*) ——— without null fill
 - - - - - with null fill and beam tilt

Polarization

H

- Superturnstile Antenna made of hot-dip galvanized steel for mounting on top of mast.
- Up to 6 bays may be built as self-supporting version. Up to 16 bays can be stacked inside a self-supporting GRP cylinder.

Input Max. power Frequency VSWR, typically Impedance Polarization Vertical radiation pattern Horizontal radiation pattern Half antenna splitting Internal connections Mounting Ice protection Grounding Max. wind velocity	Connectors according to IEC, EIA or DIN. According to customer's requirements. 174 – 230 MHz < 1.05 in the operating channel or < 1.15 in the whole range. 50 Ω Horizontal Null fill and beam tilt upon request. Omnidirectional Upon request, the antenna can be divided into two halves (for emergency operation and maintenance). The two halves are connected by a 2-way power splitter or patch panel. The radiating elements are fed with coaxial connecting cables and hybrid couplers. Connectors according to IEC, EIA or DIN are used throughout the system, allowing easy assembly and maintenance. On top of existing structure by means of a flange. The radiating slots are protected by a fiberglass cover. Cylinder provides full protection. Via mounting parts resp. via 4 grounding ropes at the exterior cylinder-surface. As required.
---	--

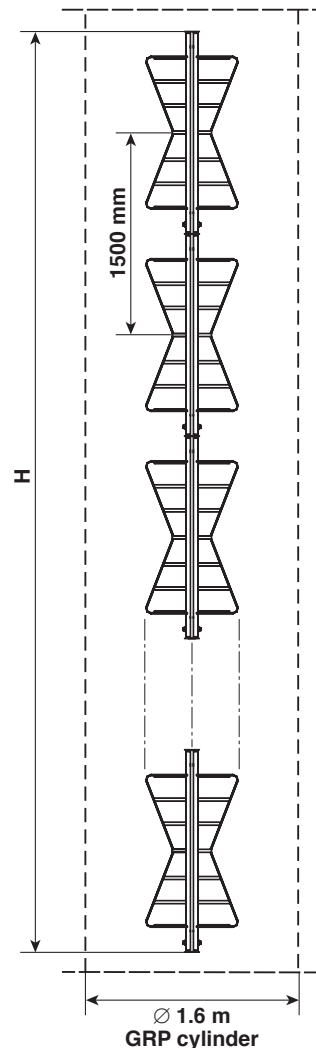

No. of bays	Gain* (at mid-band)		Weight kg		Antenna height H m	Windload** (v = 160 km/h) kN	
	dBd	times	self-supporting version	with cylinder 1.6 m ∅		self-supporting version	with cylinder 1.6 m ∅
2	4.0	2.5	430	depending on fiberglass cylinder	3.0	1.5	4.0
4	7.0	5.0	660		6.0	3.4	8.0
6	8.8	7.6	800		9.0	5.6	12.0
8	10.0	10.0	–		12.0	–	16.0
12	11.8	15.1	–		18.0	–	24.0
16	13.0	20.0	–		24.0	–	32.0

* Attenuation of the internal cabling and the gain-decrease in case of null fill in the vertical radiation pattern are not considered.
 Approximate values for gain decrease:
 cable attenuation: 0.2 – 0.4 dB
 null fill: 0.3 – 1.0 dB
 Gain figures are valid for the direction of maximum radiation (see diagrams on following page).

** Only according to antenna aperture H without base flange and top.

Typical Horizontal Radiation Pattern
(at mid-band)

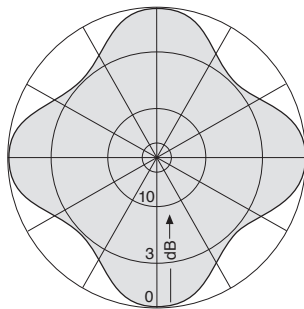

Vertical Radiation Patterns

Examples of typical **vertical** radiation patterns*) for several bays of identical, vertically stacked antenna arrays.

2 bays

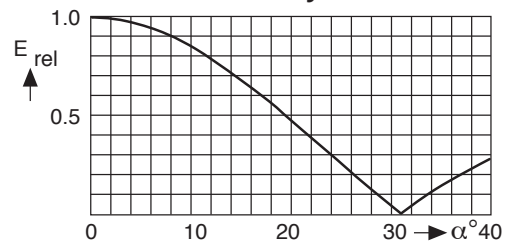

4 bays

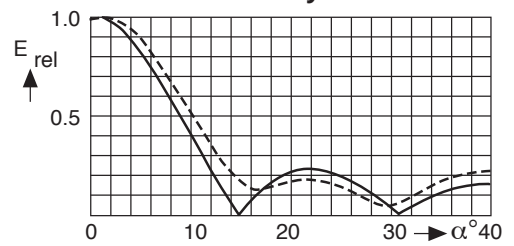

6 bays

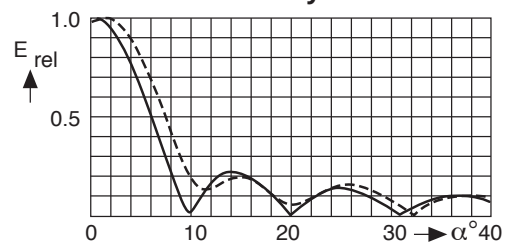

8 bays

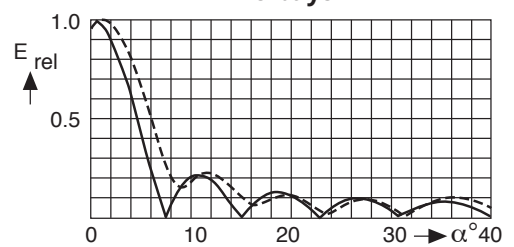

*) ——— without null fill
----- with null fill and beam tilt

Polarization V

- Antenna system consisting of special dipole panels mounted in a hexagonal configuration, in GRP cylinder with 1.6 m diameter.

Input	Connectors according to IEC, EIA or DIN.
Max. power	According to customer's requirements.
Frequency	174 – 230 MHz
VSWR, typically	< 1.2 in the whole range
Impedance	50 Ω
Polarization	Vertical
Vertical radiation pattern	Null fill and beam tilt upon request.
Horizontal radiation pattern	Omnidirectional
Half antenna splitting	Upon request, the antenna can be divided into two halves (for emergency operation and maintenance). The two halves are connected by a 2-way power splitter or patch panel.
Internal connections	The radiating elements are fed with coaxial connecting cables and power splitters. Connectors according to IEC, EIA or DIN are used throughout the system, allowing easy assembly and maintenance.
Mounting	On top of existing structure by means of a flange.
Ice protection	Cylinder provides full protection.
Grounding	Via mounting parts resp. via grounding ropes at the exterior cylinder-surface.
Max. wind velocity	As required.

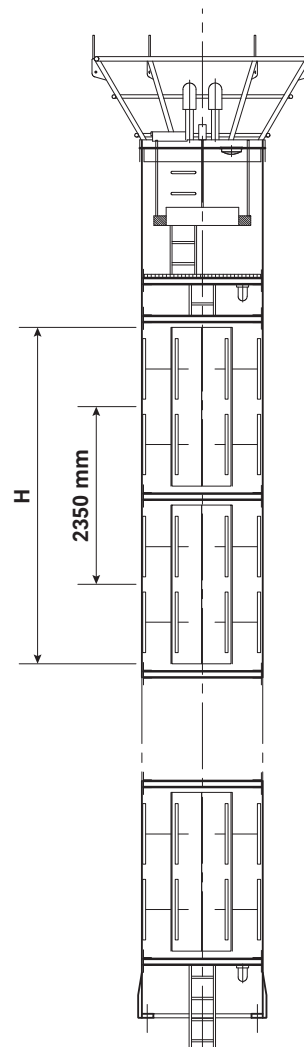

No. of bays	Gain* (at mid-band)		Weight kg with cylinder 1.6 m Ø	Antenna height H m	Windload** (v = 160 km/h) kN with cylinder 1.6 m Ø
	dBd	times			
1	3.8	2.4	depending on fiber-glass cylinder	2.3	3.1
2	6.7	4.7		4.7	6.3
3	8.5	7.1		7.0	9.3
4	9.6	9.3		9.4	12.5

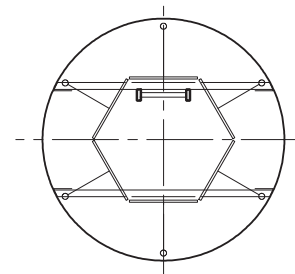

* Attenuation of the internal cabling and the gain-decrease in case of null fill in the vertical radiation pattern are not considered.

Approximate values for gain decrease:
 cable attenuation: 0.2 – 0.4 dB
 null fill: 0.3 – 1.0 dB

Gain figures are valid for the direction of maximum radiation (see diagrams on following page).

** Only according to antenna aperture H without base flange and top.

Typical Horizontal Radiation Pattern
(at mid-band)

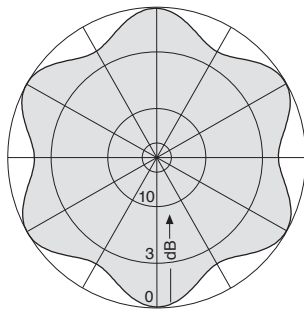

Vertical Radiation Patterns

Examples of typical **vertical** radiation patterns*) for several bays of identical, vertically stacked antenna arrays.

1 bay

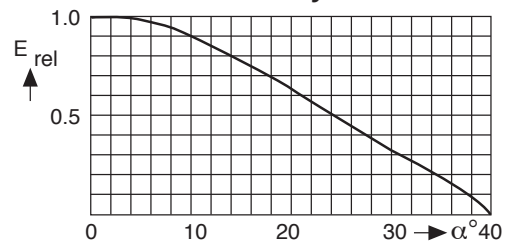

2 bays

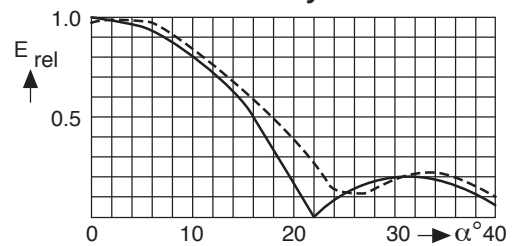

3 bays

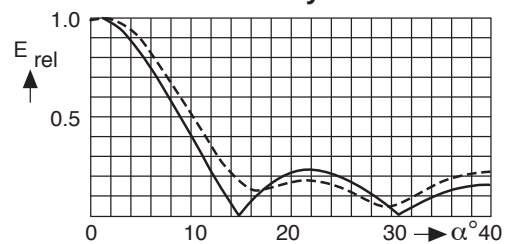

4 bays

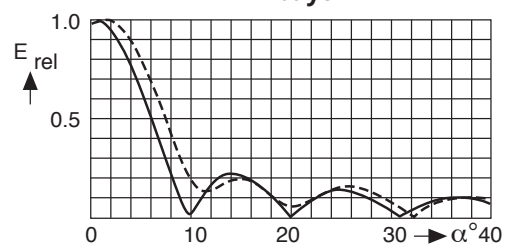

*) — without null fill
— with null fill and beam tilt

- Especially suitable for mounting at the top of masts.
- Consists of types 16911184 (lower half) and 75010365/368 (upper half), power splitter and cabling.

Splitter input	1 ⁵ / ₈ " EIA flange	3 ¹ / ₈ " EIA flange
Max. power	8 kW	16 kW
Frequency range	174 – 240 MHz	
VSWR	< 1.2	
Gain (at mid-band)	7.5 dBd	
Impedance	50 Ω	
Polarization	Vertical	
Weight	230 kg	
Wind load	2300 N (at 160 km/h)	
Bending moment	5900 Nm (at 160 km/h)	
Max. wind velocity	225 km/h	

Material of radiators: Hot-dip galvanized steel.
Weather protection: Fiberglass.

Mounting: Radiators: On top of a mast with suitable flange.
Splitter: Directly below the radiators.

Grounding: Via mounting parts.

Ice protection: Even under icy conditions the antenna is still functional due to the fiberglass covers for the feeding points.

Note: Systems with other downtilt and cable configuration are available on request.
The system may also be operated with two main-feeders, in half antenna configuration.

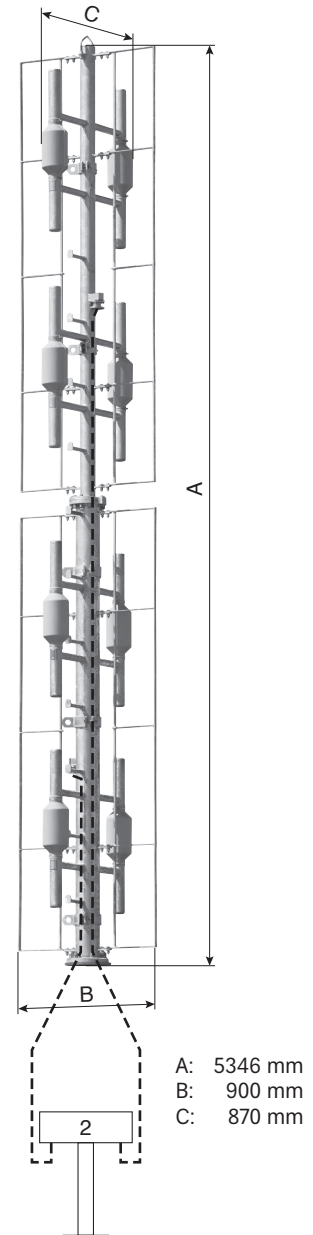

Radiation Patterns (at mid-band)

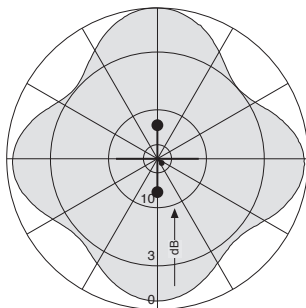

Horizontal Radiation Pattern

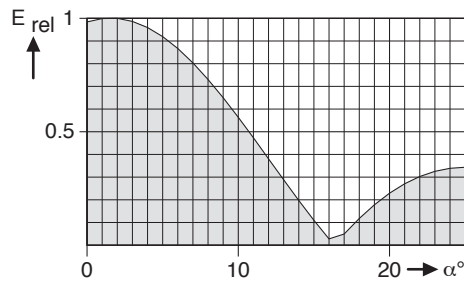

Typical Vertical Radiation Pattern at mid-band
Electrical Downtilt: 1.5°

Antennas for TV and DAB in upper VHF Band 174–240 MHz

Polarization

H

V

- Especially suitable for square masts.

Order No.	600241 K523057	602036 K523058
Input	7-16 female	7/8" EIA flange
Max. power	2 kW	2.5 kW
Frequency range	174 - 230 MHz	
VSWR	< 1.08	
Gain (at mid-band)	8 dBd	
Impedance	50 Ω	
Polarization	Horizontal or vertical	
Weight	23 kg	
Wind load (at 160 km/h)	Frontal / lateral: 750 N / 315 N	
Horizontal:	Frontal / lateral: 750 N / 375 N	
Vertical:		
Max. wind velocity	240 km/h	

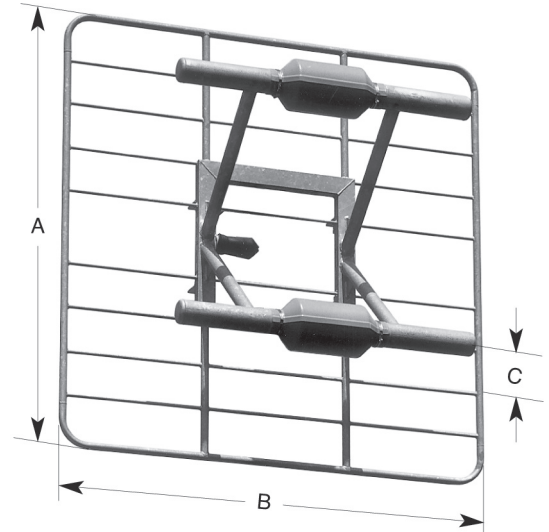

A: ~ 1300 mm
B: ~ 1300 mm
C: ~ 415 mm

- Material:** Hot-dip galvanized steel.
Weather protection: Fiberglass.
- Mounting:** By means of the pair of hot-dip galvanized steel clamps:
75310466 to pipes of 60-115 mm Ø
75310465 to pipes of 115-210 mm Ø
(please order separately).
Mounting dimensions upon request.
- Grounding:** Via mounting parts.
- Ice protection:** Even under severe icy conditions the antenna is still functional due to its heavy-duty construction and the fiberglass covers for the feeding points.
- Scope of supply:** Antenna without mounting clamps.

Radiation Patterns (at mid-band)

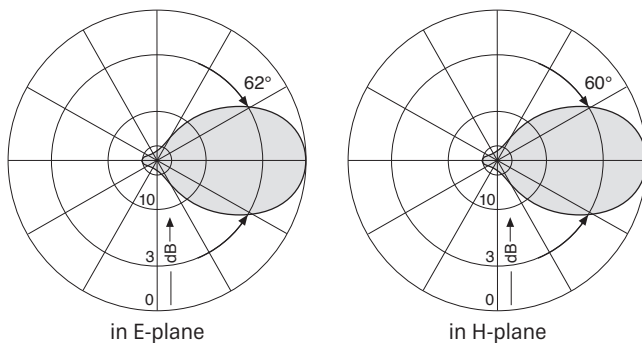

- Especially suitable for square and round masts.

Order No.	75010350	75010352
Input	7-16 female	13-30 female
Max. power	2 kW	4 kW
Frequency range	174 - 240 MHz	
VSWR	174 - 230 MHz: < 1.15 230 - 240 MHz: < 1.2	
Gain (at mid-band)	8 dBd	
Impedance	50 Ω	
Polarization	Vertical	
Weight	35 kg	
Wind load (at 160 km/h)	Frontal: 500 N Lateral: 690 N	
Max. wind velocity	240 km/h	

- Material:** Hot-dip galvanized steel.
Weather protection: Fiberglass.
- Mounting:** Mounting hardware and mounting dimensions upon request.
- Grounding:** Via mounting parts.
- Ice protection:** Even under severe icy conditions the antenna is still functional due to its heavy-duty construction and the fiberglass covers for the feeding points.
- Scope of supply:** Antenna without mounting clamps.
- Special features:** The antenna is shipped dismounted.

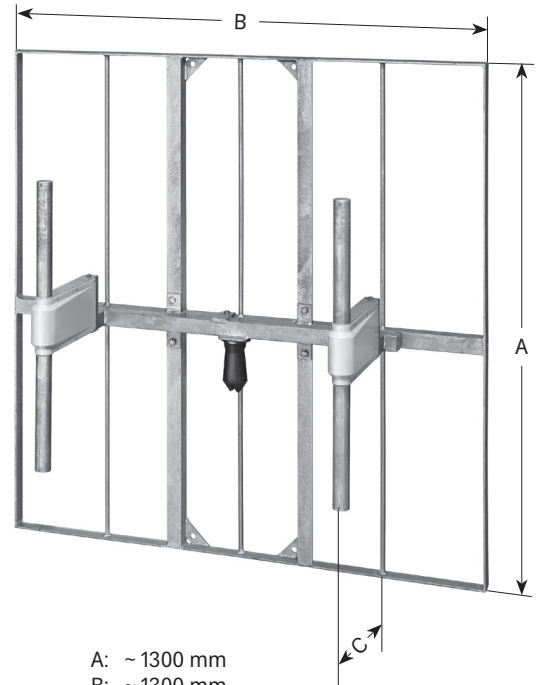

A: ~ 1300 mm
B: ~ 1300 mm
C: ~ 400 mm

Antennas
174 - 240 MHz

Radiation Patterns (at mid-band)

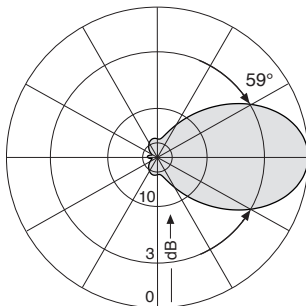

Horizontal Radiation Pattern

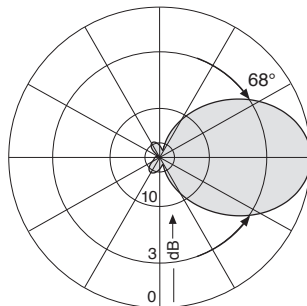

Vertical Radiation Pattern

- Especially suitable for triangular and round masts.

Order No.	601157 K5234517	601835 K5234527
Input	7-16 female	
Max. power	2 kW	
Frequency range	174 – 202 MHz	202 – 240 MHz
VSWR	< 1.15	
Gain (at mid-band)	7 dBd	
Impedance	50 Ω	
Polarization	Horizontal	
Weight	20 kg	
Wind load (at 160 km/h)	Frontal: 375 N	Lateral: 375 N
Max. wind velocity	240 km/h	

- Material:** Hot-dip galvanized steel.
Weather protection: Fiberglass.
- Mounting:** By means of the pair of hot-dip galvanized steel clamps:
75310466 to pipes of 60–115 mm Ø
75310465 to pipes of 115–210 mm Ø
(please order separately).
Further mounting hardware and mounting dimensions upon request.
- Grounding:** Via mounting parts.
- Ice protection:** Even under severe icy conditions the antenna is still functional due to its heavy-duty construction and the fiberglass covers for the feeding points.
- Scope of supply:** Antenna without mounting clamps.

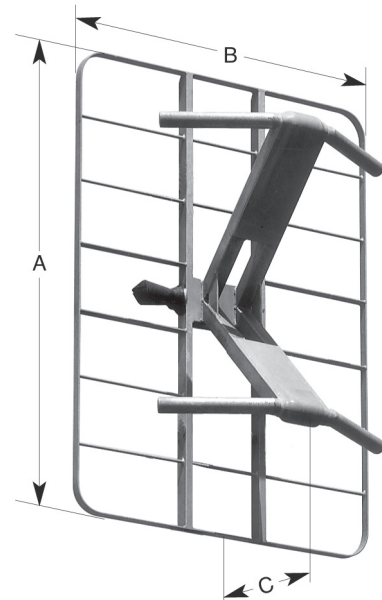

A: ~ 1200 mm
B: ~ 860 mm
C: ~ 405 mm

Radiation Patterns (at mid-band)

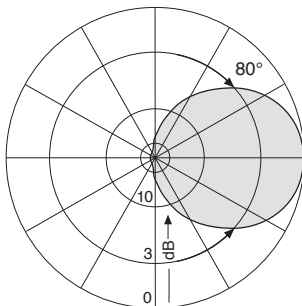

Horizontal Radiation Pattern

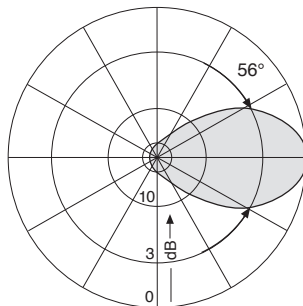

Vertical Radiation Pattern

Panel Antenna

174-230 MHz

KATHREIN

Polarization

H

V

- Light weight panel of weather-resistant aluminum.

Order No.	600256 K523157
Input	7-16 female
Max. power	1 kW
Frequency range	174 - 230 MHz
VSWR	< 1.15
Gain (at mid-band)	7.5 dBd
Impedance	50 Ω
Polarization	Horizontal or vertical by conversion of two clamps
Weight	7 kg
Wind load (at 160 km/h)	
Horizontal:	Frontal / lateral: 440 N / 250 N
Vertical:	Frontal / lateral: 440 N / 350 N
Max. wind velocity	
Horizontal:	225 km/h
Vertical:	200 km/h

Material: Weather-resistant aluminum.

Mounting: To pipes of 60 - 115 mm Ø by means of mounting clamps, supplied.

Grounding: Via mounting parts.

Special features: The antenna will be shipped dismantled.

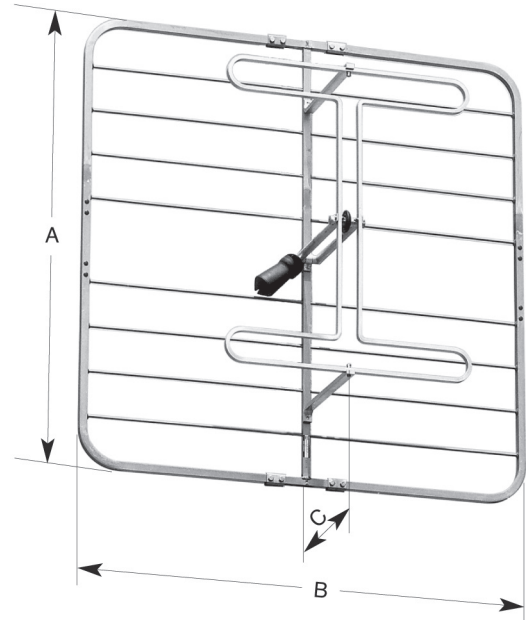

A: ~ 1200 mm
B: ~ 1200 mm
C: ~ 360 mm

Antennas
174 - 230 MHz

Radiation Patterns (at mid-band)

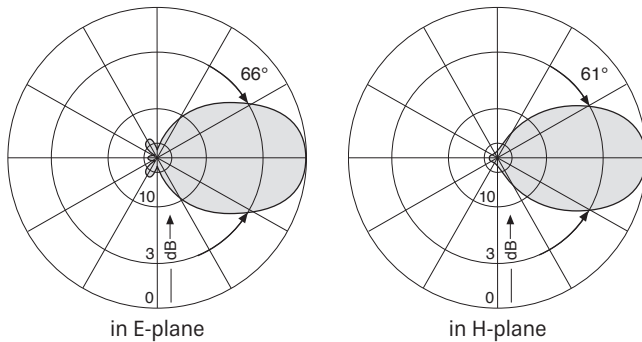

Polarization

H V X

- Dual-polarized antenna (horizontal/vertical).
- Optionally circular or slant polarization.
- For TV and DAB in one system.

Order No.	75010085
Input	2 x 7-16 female
Max. power	2 kW per input
Frequency range	174 - 223 MHz
for vertical polarization	174 - 240 MHz
VSWR	< 1.2 (linear polarization) < 1.1 (circular polarization)
Gain (at mid-band)	7.5 dBd
Impedance	50 Ω
Polarization	Linear: horizontal, vertical, slant circular
Weight	35 kg
Wind load (at 160 km/h)	Frontal: 850 N Lateral: 720 N
Max. wind velocity	225 km/h

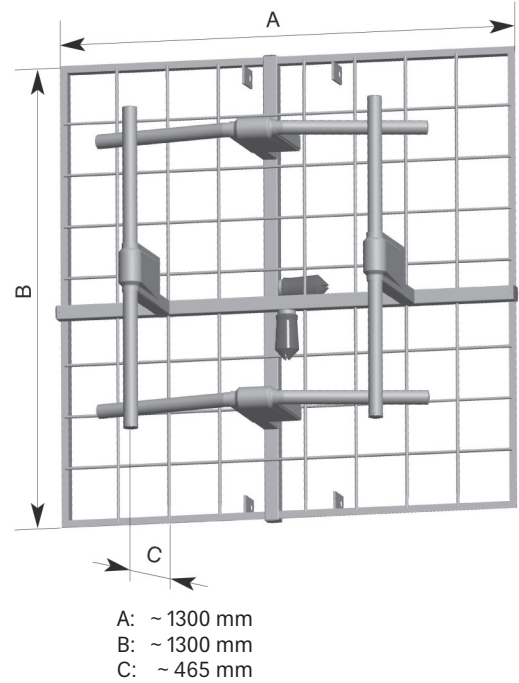

- Material:** Hot-dip galvanized steel.
Radome: Fiberglass.
- Mounting:** Using M16 screws (supplied) to suitable attachment construction.
Mounting dimensions upon request.
- Grounding:** Via mounting parts.
- Ice protection:** Even under severe icy conditions the antenna is still functional due to its heavy-duty construction and the fiberglass covers for the feeding points.
- Scope of supply:** Antenna supplied without clamps.

Radiation Patterns for horizontal polarization
(at mid-band)

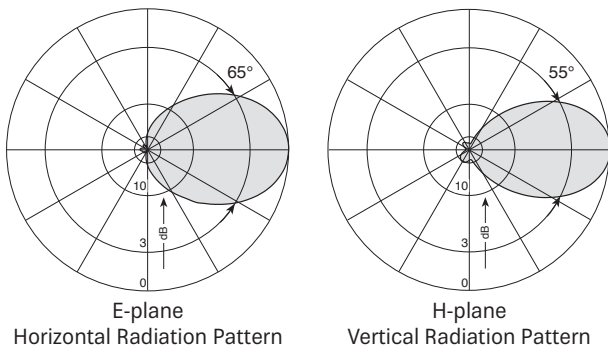

Radiation Patterns for vertical polarization
(at mid-band)

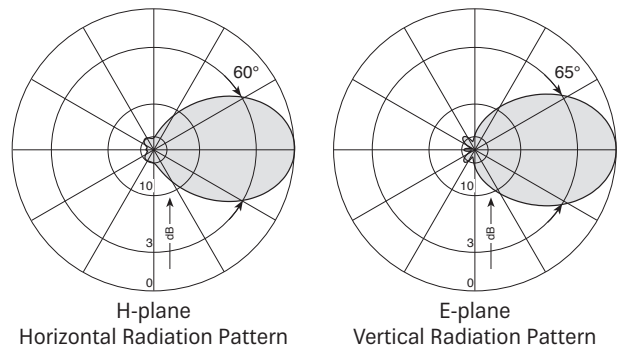

Yagi Antenna

174...230 MHz

KATHREIN

Polarization

H

- For low power transmitting antennas or Rx applications.

Order No.	600265 K5240517	600267 K5240527
Input	7-16 female	
Max. power	100 W	400 W
Frequency range	174 – 202 MHz	202 – 230 MHz
VSWR	< 1.15	
Gain (at mid-band)	6 dBd	
Impedance	50 Ω	
Polarization	Horizontal	
Weight	5 kg	
Wind load (at 160 km/h)		
Frontal:	115 N	100 N
Lateral:	100 N	90 N
Max. wind velocity	225 km/h	
Dimensions (approx.)		
A	930 mm	810 mm
B	885 mm	765 mm

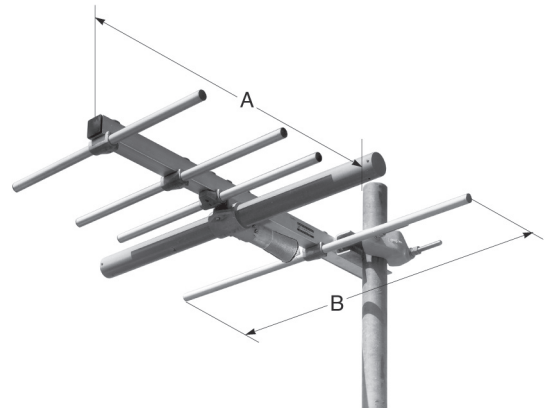

- Material: Weather-proof aluminum.
Radiator in fiberglass radome.
- Mounting: To pipes of 60–115 mm \varnothing by means of mounting clamps, supplied.
- Grounding: Via mounting parts.
- Special features: The antenna is shipped dismounted.

Radiation Patterns (at mid-band)

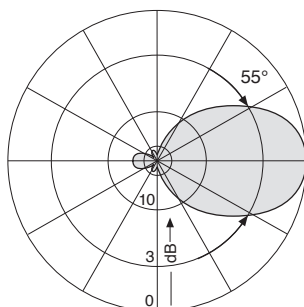

Horizontal Radiation Pattern

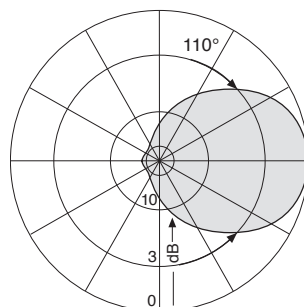

Vertical Radiation Pattern

Yagi Antenna

174...242 MHz

KATHREIN

Polarization

V

- For low power transmitting antennas or Rx applications.

Order No.	75010028	75010033	768494
Input	7-16 female		
Max. power	400 W		
Frequency range	174 - 202 MHz	202 - 230 MHz	215 - 242 MHz
VSWR	< 1.2		
Gain (at mid-band)	6 dBd		
Impedance	50 Ω		
Polarization	Vertical		
Weight	5 kg		
Wind load (at 160 km/h)			
Frontal:	115 N		100 N
Lateral:	200 N		150 N
Max. wind velocity	225 km/h		

Material: Weather-resistant aluminum.
Radiator in fiberglass radome.

Mounting: To pipes of 60-115 mm Ø by means of mounting clamps, supplied.

Grounding: Via mounting parts.

Special features: The antenna will be shipped dismantled.

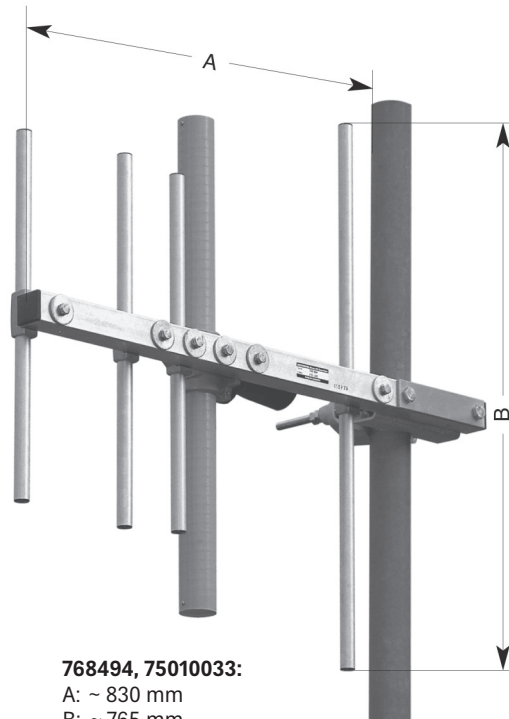

768494, 75010033:

A: ~ 830 mm
B: ~ 765 mm

75010028:

A: ~ 930 mm
B: ~ 882 mm

Radiation Patterns (at mid-band)

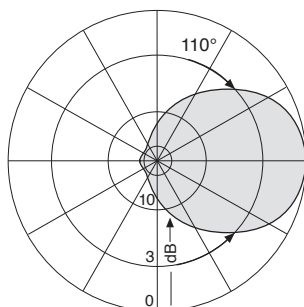

Horizontal Radiation Pattern

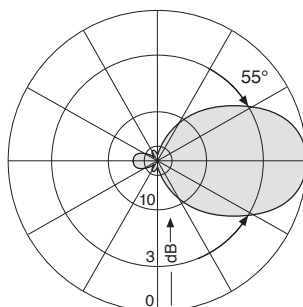

Vertical Radiation Pattern

Polarization

H

V

- Logarithmic-periodic broadband directional antenna.

Order No.	75010242
Input	7-16 female
Max. power	2 kW
Frequency range	174 - 240 MHz
VSWR	174 - 230 MHz: ≤ 1.25 230 - 240 MHz: ≤ 1.3
Gain (at mid-band)	5 dBd
Impedance	50 Ω
Polarization	Horizontal or vertical
Weight	10 kg
Wind load (at 160 km/h)	Frontal: 100 N Lateral: 190 N
Max. wind velocity	225 km/h

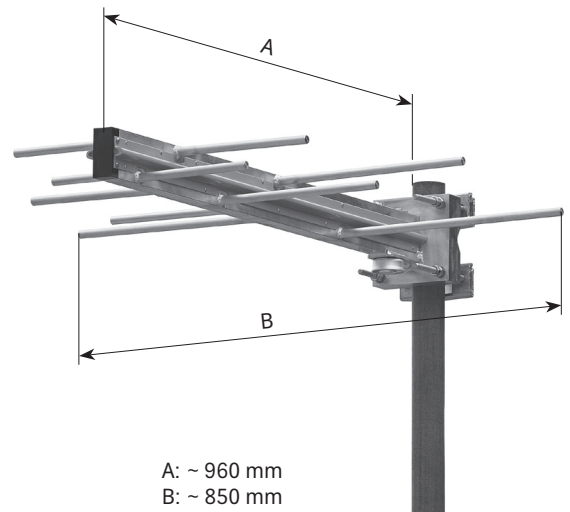

Material: Hot-dip galvanized steel.
 Mounting: To pipes of 40-95 mm diameter by means of mounting clamps, supplied.
 Grounding: Via mounting parts.

Radiation Patterns (at mid-band)

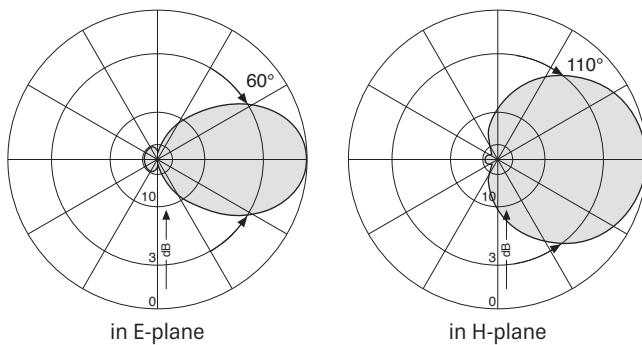

Polarization

H

V

- Logarithmic-periodic broadband directional antenna with high side-lobe suppression.

Order No.	600234 K522257
Input	7-16 female
Max. power	1 kW
Frequency range	174 - 230 MHz
VSWR	< 1.2
Gain (at mid-band)	8.5 dBd
Impedance	50 Ω
Polarization	Horizontal or vertical
Side-lobe suppression	> 25 dB
Weight	27 kg
Wind load (at 160 km/h)	
Horizontal:	Frontal / lateral: 240 N / 525 N
Vertical:	Frontal / lateral: 240 N / 350 N
Max. wind velocity	225 km/h

Material: Hot-dip galvanized steel.

Mounting: To pipes of 60-115 mm \varnothing by means of mounting clamps, supplied.

Grounding: Via mounting parts.

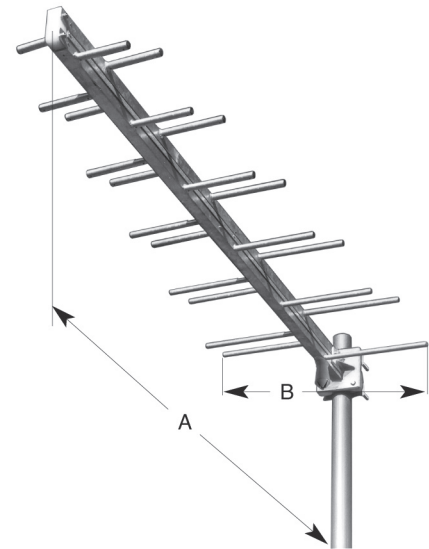

A: ~ 2300 mm
B: ~ 890 mm

Radiation Patterns (at mid-band)

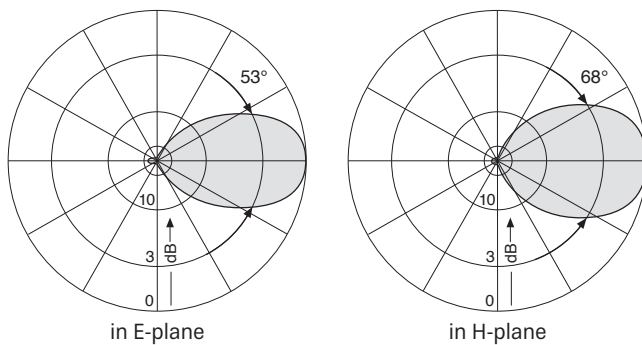

Dipole Antenna

195–230 MHz

KATHREIN

Polarization

V

- Omnidirectional antenna with preferred direction of radiation.
- Mounting to tubular masts.

Order No.	774846
Input	7-16 female
Max. power	2 kW
Frequency range	195 – 230 MHz
VSWR	< 1.25
Gain (at mid-band)	2 dBd
Impedance	50 Ω
Polarization	Vertical
Weight	6 kg
Wind load (at 160 km/h)	Lateral: 90 N
Max. wind velocity	225 km/h

Material: Hot-dip galvanized steel.

Mounting: To pipes of 60–125 mm diameter by means of mounting clamp, supplied.

Grounding: Via mounting parts.



A: ~ 645 mm
B: ~ 440 mm

Antennas
174 – 240 MHz

Radiation Patterns (at mid-band)

(Radiator mounted onto a slim steel tube,
tower effects not considered)

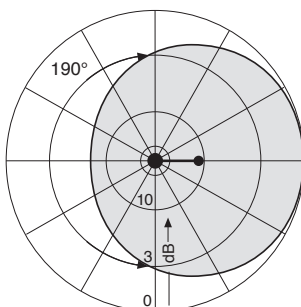

Horizontal Radiation Pattern

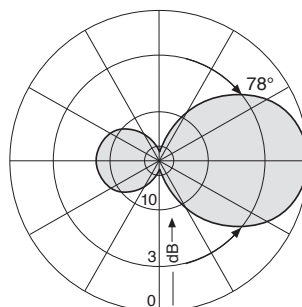

Vertical Radiation Pattern

- Hot-dip galvanized steel.
- Especially suitable for mounting at the top of masts.

Order No.	75010290	75010291	75010292
Input	7-16 female	7/8" EIA flange	1 1/2" EIA flange
Max. power	2 kW	3 kW	5 kW
Frequency range	174 - 240 MHz		
VSWR	< 1.2		
Gain (at mid-band)	4.5 dBd		
Impedance	50 Ω		
Polarization	Vertical		
Weight	30 kg		
Wind load (at 160 km/h)	Frontal: 380 N	Lateral: 460 N	
Max. wind velocity	240 km/h		

Material: Hot-dip galvanized steel.
Weather protection: Fiberglass.

Mounting: On top of a suitable flange with at least 135 mm diameter (see draft).

Grounding: Via mounting parts.

Ice protection: Even under icy conditions the antenna is still functional due to the fiberglass covers for the feeding points.

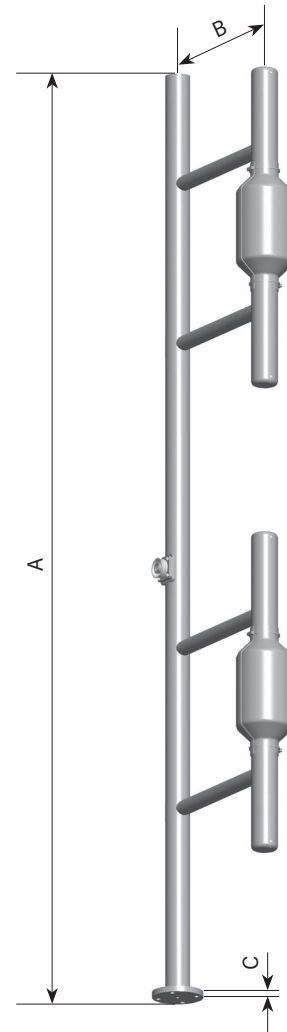

A: ~ 2537 mm
B: ~ 460 mm
C: ~ 15 mm

Radiation Patterns (at mid-band)

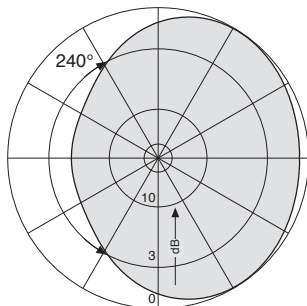

Horizontal Radiation Pattern

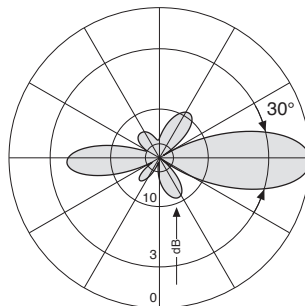

Vertical Radiation Pattern
1.5° electrical downtilt

Dipole Antenna

174-240 MHz

KATHREIN

Polarization

V

- Hot-dip galvanized steel.
- For side-mounting to masts.

Order No.	75010295	75010296	75010297
Input	7-16 female	7/8" EIA flange	1 1/8" EIA flange
Max. power	2 kW	3 kW	5 kW
Frequency range	174 - 240 MHz		
VSWR	< 1.2		
Gain (at mid-band)	5.0 dBd		
Impedance	50 Ω		
Polarization	Vertical		
Weight	24 kg		
Wind load (at 160 km/h)	Frontal: 480 N Lateral: 540 N		
Max. wind velocity	240 km/h		

Material: Hot-dip galvanized steel.
Weather protection: Fiberglass.

Mounting: Laterally using 8 screws M12x60 to suitable flange.

Grounding: Via mounting parts.

Ice protection: Even under icy conditions the antenna is still functional due to the fiberglass covers for the feeding points.

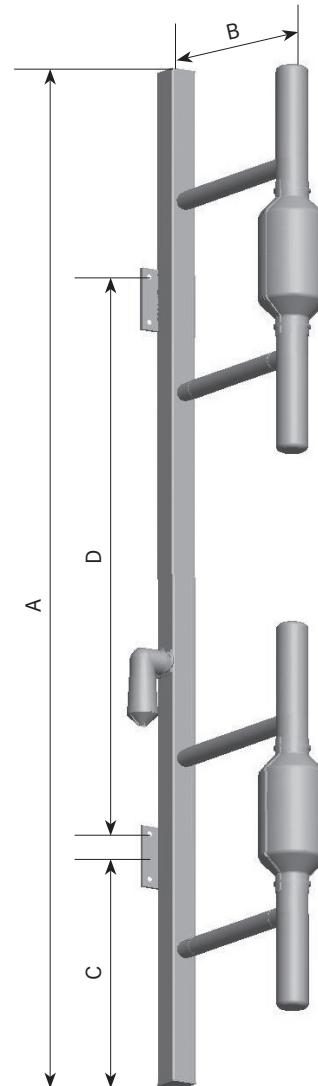

A: ~ 2326 mm
B: ~ 460 mm
C: ~ 520 mm
D: ~ 1280 mm

Radiation Patterns (at mid-band)

(Radiator mounted onto a slim steel tube, tower effects not considered)

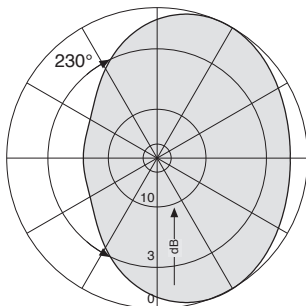

Horizontal Radiation Pattern

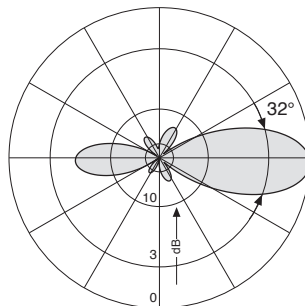

Vertical Radiation Pattern
1.5° electrical downtilt

- Omnidirectional antenna for top mounting.

Order No.	75010365	75010366	75010367	75010368
Input	7-16 female	7/8" EIA flange	13-30 female	1 1/2" EIA flange
Max. power	2 kW	3 kW	5 kW	8 kW
Frequency range	174 - 240 MHz			
VSWR	< 1.2			
Gain (at mid-band)	4.5 dBd			
Impedance	50 Ω			
Polarization	Vertical			
Weight	80 kg			
Wind load (at 160 km/h)	1080 N			
Max. wind velocity	225 km/h			

Material: Hot-dip galvanized steel.
Weather protection: Fiberglass.

Mounting: On top of a suitable flange.

Grounding: Via mounting parts.

Ice protection: Even under icy conditions the antenna is still functional due to the fiberglass covers for the feeding points.

Note: Antenna may be mounted on top of Type 16911184 for higher gain.
For climbing in the antenna special climbing rungs and attachment points for climbing safety are provided.
Reflector grid and dipole parts must **not** be used for climbing!

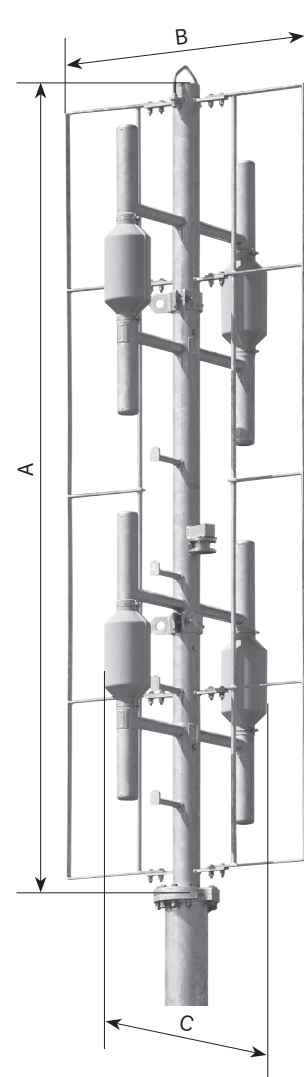

A: ~ 2625 mm
B: ~ 900 mm
C: ~ 870 mm

Radiation Patterns (at mid-band)

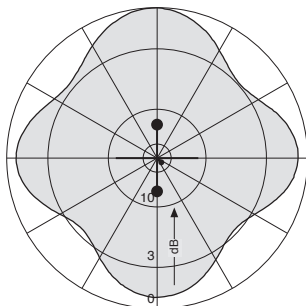

Horizontal Radiation Pattern

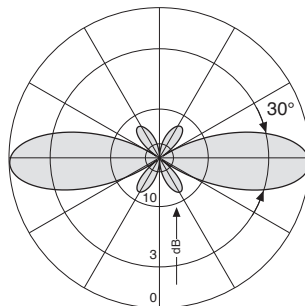

Vertical Radiation Pattern
Electrical downtilt: 2.0°

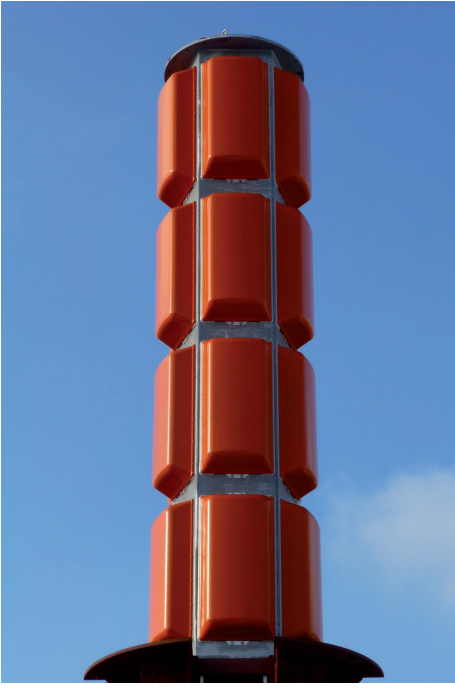

Antenna Systems 470–862 MHz

Broadcast Station "Brasilia", Brazil



Systems
470 – 862 MHz

Polarization

H
V

- Antenna systems consisting of dipole panels (page 88, 89) for various radiation patterns.
- The feeder network is made up of coaxial power splitters and flexible connecting cables in accordance with the radiation patterns specification and the transmitter power.

Input	Connectors according to IEC, EIA or DIN.
Max. power	According to customer's requirements.
Frequency	470 – 862 MHz
VSWR, typically	< 1.05 in the operating channels after tuning or < 1.15 in band. In GRP cylinder or radomized structure: < 1.2 in band.
Impedance	50 Ω
Polarization	Horizontal or vertical
Internal connections	Connectors according to IEC, EIA or DIN are used throughout the system, allowing easy assembly and maintenance.
Vertical radiation pattern	Null fill and beam tilt upon request.
Horizontal radiation pattern	Omnidirectional, directional or custom-designed.
Half antenna splitting	Upon request, the antenna can be divided into two halves (for emergency operation and maintenance). The two halves are connected by a 2-way power splitter or patch panel.
Pressurization	Splitters and connecting cables can be supplied with dry air (please specify when ordering).
Structure	3 versions are available: a) Panels mounted on hot-dip galvanized steel spine. b) like a), covered by fiberglass radome 1.2 m ∅ c) Panels mounted inside self-supporting fiberglass cylinder (1.6 m ∅)
Grounding	Via mounting parts.
Max. wind velocity	As required.

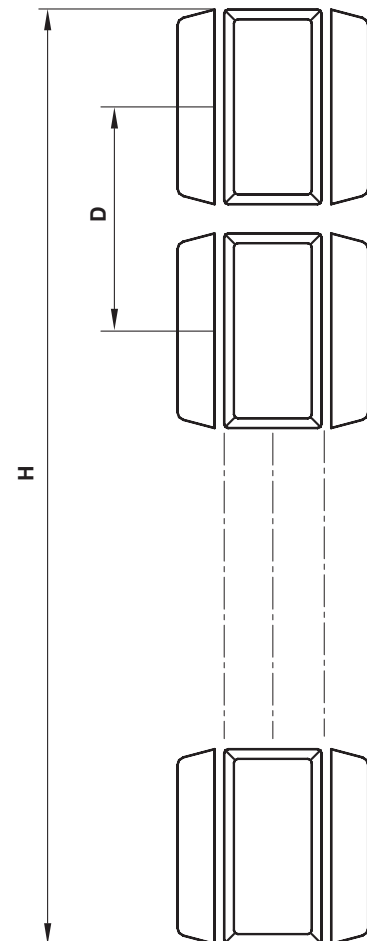

D = 1150 mm on spine /
 behind radome 1.2 m ∅
 D = 1100 mm in GRP cylinder 1.6 m ∅

No. of bays	Panels per bay	Gain* (at mid-band)		Weight** (without mounting hardware) kg	Antenna height H / m		Windload / kN (v = 160 km/h)			
		dBd	times		on spine	in GRP cylinder 1.6 m ∅	without cylinder**	behind radome 1.2 m ∅***	GRP cylinder 1.6 m ∅***	
4	2	15.0	31.6	120	4.45	4.3	5.2	6.4	4.5	6.0
	3	13.6	22.9	160						
	4	11.8	15.1	210						
6	2	16.8	47.9	170	6.75	6.5	7.8	9.6	7.0	9.0
	3	15.4	34.7	240						
	4	13.6	22.9	330						
8	2	18.0	63.1	240	9.05	8.7	10.4	12.8	9.0	12.0
	3	16.6	45.7	320						
	4	14.8	30.2	420						
12	2	19.8	95.5	350	13.65	13.1	15.6	19.2	14.0	18.0
	3	18.4	69.2	490						
	4	16.6	45.7	670						
16	2	21.0	125.9	450	18.25	17.5	20.8	25.6	20.0	24.0
	3	19.6	91.2	690						
	4	17.8	60.3	890						

* Attenuation of the internal cabling and the gain-decrease in case of null fill in the vertical radiation pattern are not considered.

Approximate values for gain decrease:

cable attenuation: 0.2 – 0.5 dB

null fill: 0.3 – 1.0 dB

Gain figures are valid for the direction of maximum radiation (see diagrams on following page).

** Average values, depending on design and arrangement.

*** Only according to antenna aperture H without base flange and top.

Polarization

H **V**

Horizontal Radiation Patterns

Examples of typical horizontal antenna arrays and their **horizontal** radiation patterns for optimal mast dimensions.

Equal power splitting

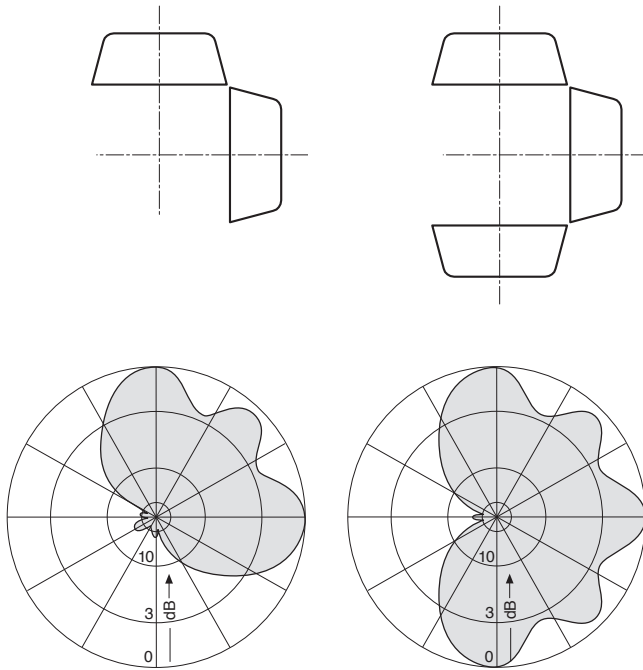

Equal power splitting

Different power splitting

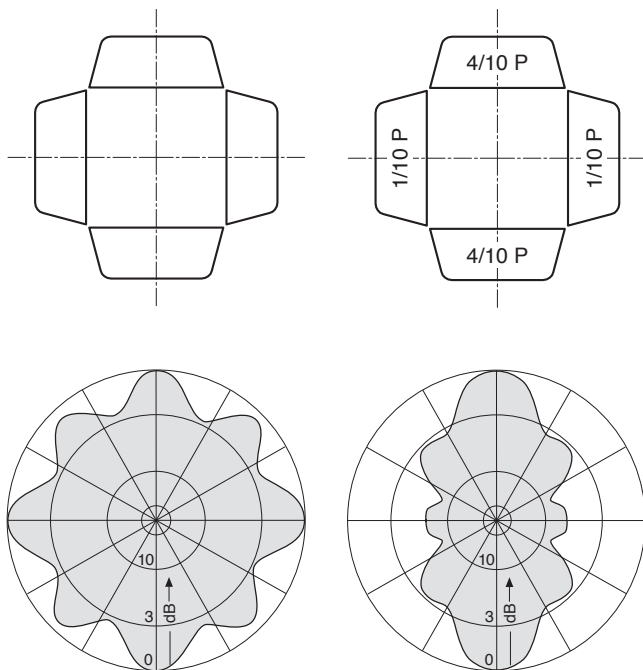

Vertical Radiation Patterns

Examples of typical **vertical** radiation patterns*) for several bays of identical, vertically stacked antenna arrays.

4 bays

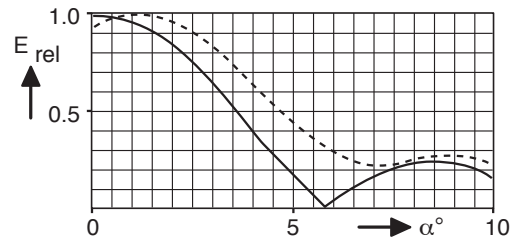

8 bays

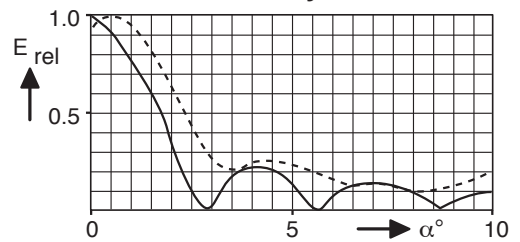

12 bays

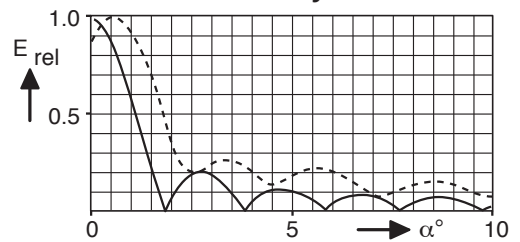

16 bays

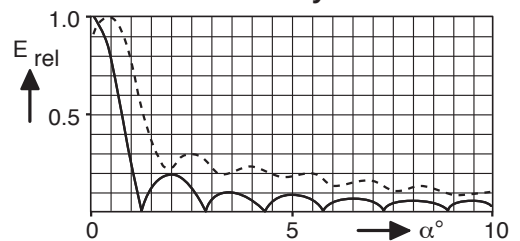

*) — without null fill
 - - - with null fill and beam tilt

Polarization H

- Superturnstile antenna in a self-supporting fiberglass cylinder with 1.60 m diameter.

Input	Connectors according to IEC, EIA or DIN.
Max. power	According to customer's requirements, 6 kW max. per bay.
Frequency	470 – 862 MHz
VSWR, typically	< 1.05 in operating channels after tuning or < 1.15 in band.
Impedance	50 Ω
Polarization	Horizontal
Vertical radiation pattern	Null fill and beam tilt upon request.
Horizontal radiation pattern	Omnidirectional, circularity < ±1.5 dB
Half antenna splitting	Upon request, the antenna can be divided into two halves (for emergency operation and maintenance). The two halves are connected by a 2-way power splitter or patch panel.
Internal connections	The radiating elements are fed with coaxial connecting cables and hybrid couplers. Connectors according to IEC, EIA or DIN are used throughout the system, allowing easy assembly and maintenance.
Structure	Superturnstile antenna in self-supporting fiberglass-cylinder. Up to 16 bays may be stacked.
Mounting	On top of existing structure by means of a flange.
Ice protection	Fiberglass-cylinder (= supporting structure)
Grounding	Via mounting parts resp. via 4 grounding ropes at the exterior cylinder-surface.

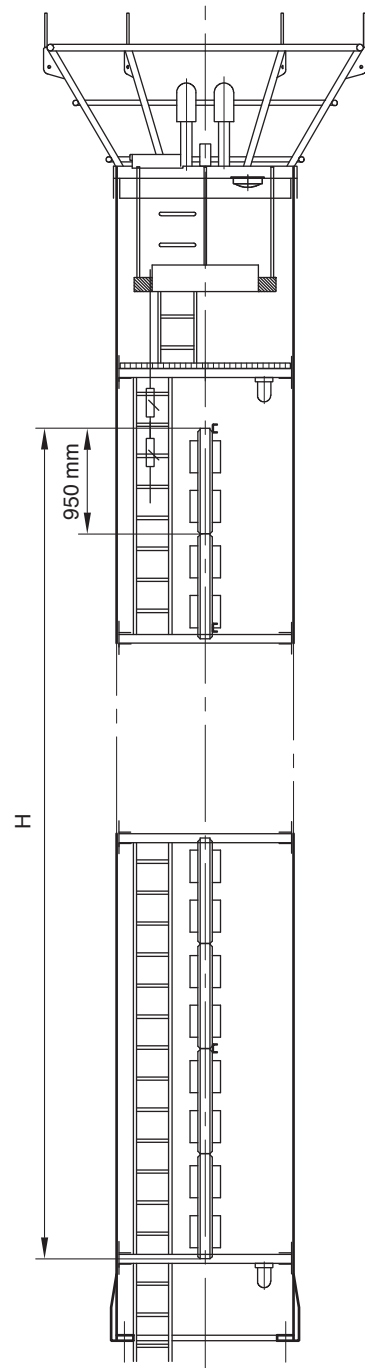

No. of bays	Gain*		Weight** kg	Antenna height H m	Windload** (v = 160 km/h) kN
	(at mid-band) dBd	times			
2	7.7	5.9	350	1.9	2.5
4	10.7	11.8	700	3.8	5.0
8	13.7	23.4	1400	7.6	10.0
12	15.5	35.5	2200	11.4	15.0
16	16.7	46.8	3050	15.2	20.0

* Attenuation of the internal cabling and the gain-decrease in case of null fill in the vertical radiation pattern are not considered.

Approximate values for gain decrease:
cable attenuation: 0.2 – 0.5 dB
null fill: 0.3 – 1.0 dB

Gain figures are valid for the direction of maximum radiation (see diagrams on following page).

** Only according to antenna aperture H without base flange and top.

Typical Horizontal Radiation Pattern
(at mid-band)

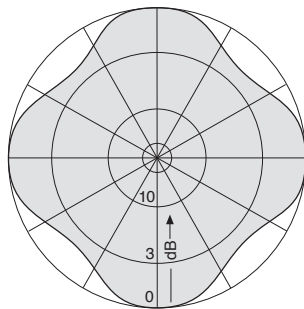

Vertical Radiation Patterns

Examples of typical **vertical** radiation patterns*) for several bays of identical, vertically stacked antenna arrays.

4 bays

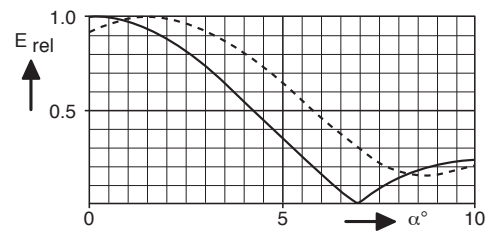

8 bays

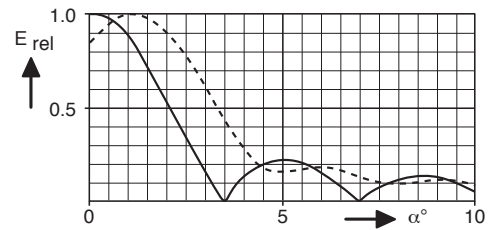

12 bays

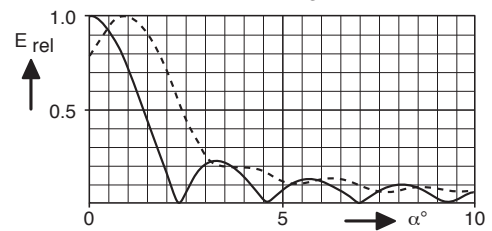

16 bays

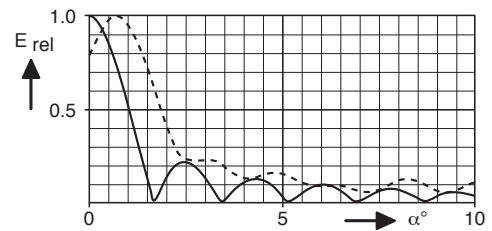

*) ——— without null fill
----- with null fill and beam tilt

Polarization H

- Antenna systems consisting of special dipole panels mounted on a pentagonal steel spine.
- The feeder network is made up of coaxial power splitters and flexible connecting cables in accordance with the radiation patterns specification and the transmitter power.

Input	Connectors according to IEC, EIA or DIN.
Max. power	According to customer's requirements.
Frequency	470 – 750 (806) MHz
VSWR, typically	< 1.15 in operation channels after tuning > 1.2 in band.
Impedance	50 Ω
Polarization	Horizontal
Internal connections	Connectors according to IEC, EIA or DIN are used throughout the system, allowing easy assembly and maintenance.
Vertical radiation pattern	Null fill and beam tilt upon request.
Horizontal radiation pattern	Omnidirectional, circularity < ±1.5 dB.
Half antenna splitting	Upon request, the antenna can be divided into two halves (for emergency operation and maintenance). The two halves are connected by a 2-way power splitter or patch panel.
Pressurization	Splitters and connecting cables can be supplied with dry air (please specify when ordering).
Structure	Panels mounted on hot-dip galvanized steel spine.
Grounding	Via mounting parts.
Max. wind velocity	As required.

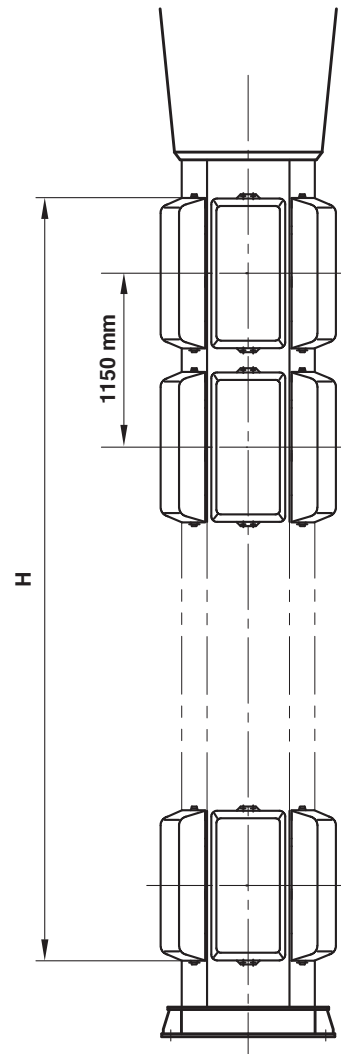

No. of bays	Panels per bay	Gain* (at mid-band)		Weight** kg	Antenna height H m	Windload** (v = 160 km/h) kN
		dBd	times			
4	5	11.7	14.8	1600	4.45	7
6	5	13.5	22.4	2100	6.75	10
8	5	14.8	30.2	3000	9.05	14
12	5	16.5	44.7	4300	13.65	21
16	5	17.8	60.3	5900	18.25	29

* Attenuation of the internal cabling and the gain-decrease in case of null fill in the vertical radiation pattern are not considered.

Approximate values for gain decrease:
 cable attenuation: 0.2 – 0.5 dB
 null fill: 0.3 – 1.0 dB

Gain figures are valid for the direction of maximum radiation (see diagrams on following page).

** Only according to antenna aperture H without base flange and top.

Horizontal Radiation Patterns

Examples of typical horizontal antenna arrays and their **horizontal** radiation patterns.

Omnidirectional patterns

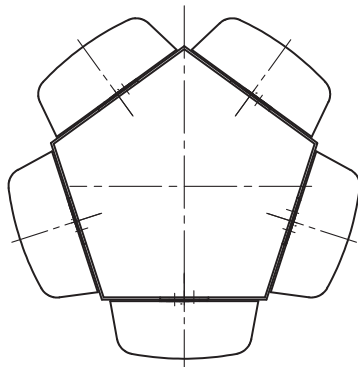

Directional patterns on request!

Vertical Radiation Patterns

Examples of typical **vertical** radiation patterns*) for several bays of identical, vertically stacked antenna arrays.

4 bays

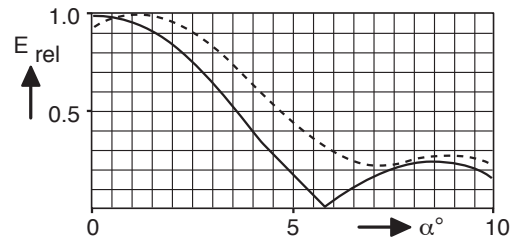

8 bays

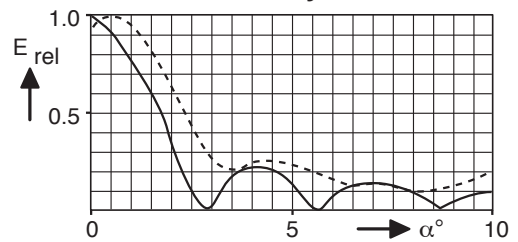

12 bays

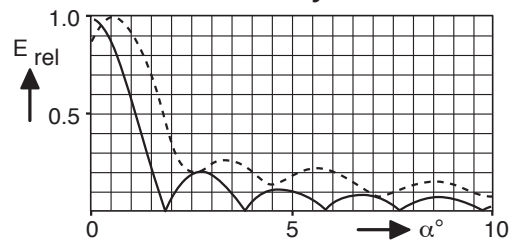

16 bays

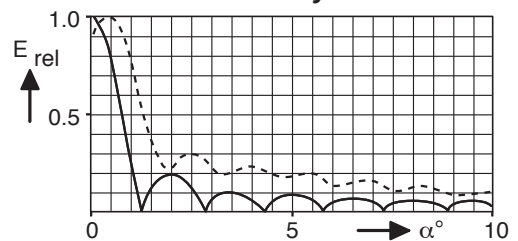

*) ——— without null fill
 - - - - - with null fill and beam tilt

Polarization V

- Antenna systems consisting of special dipole panels mounted in an octagonal configuration, on steel spine or in GRP cylinder.
- The feeder network is made up of coaxial power splitters and flexible connecting cables in accordance with the radiation patterns specification and the transmitter power.

Input	Connectors according to IEC, EIA or DIN.
Max. power	According to customer's requirements.
Frequency	470 – 862 MHz
VSWR, typically	< 1.2 in band
Impedance	50 Ω
Polarization	Vertical
Internal connections	Connectors according to IEC, EIA or DIN are used throughout the system, allowing easy assembly and maintenance.
Vertical radiation pattern	Null fill and beam tilt upon request.
Horizontal radiation pattern	Omnidirectional, circularity < ±1 dB (directional or custom-designed on request).
Half antenna splitting	Upon request, the antenna can be divided into two halves (for emergency operation and maintenance). The two halves are connected by a 2-way power splitter or patch panel.
Pressurization	Splitters and connecting cables can be supplied with dry air (please specify when ordering).
Structure	2 versions are available: a) Panels mounted on hot-dip galvanized steel spine. b) Panels mounted inside self-supporting fiberglass cylinder (1.6 m Ø)
Grounding	Via mounting parts.
Max. wind velocity	As required.

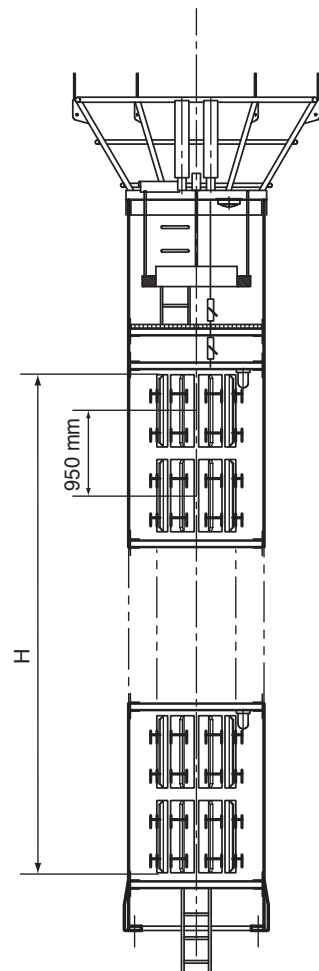
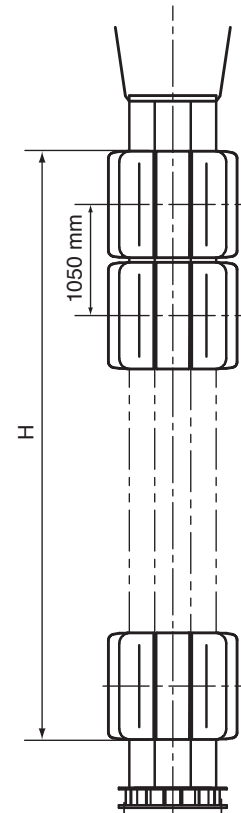

No. of bays	Panels per bay	Gain* (at mid-band)		Weight** (kg)		Antenna height H / m		Windload / kN (v = 160 km/h)	
		dBd	times	with spine	with cylinder 1.6 m Ø	with spine	with cylinder 1.6 m Ø	with spine **	with cylinder 1.6 m Ø ***
4	8	10.3	10.7	1500	1100	4.15	3.72	6.5	5.0
6	8	12.1	16.2	2100	1650	6.25	5.62	9.5	7.5
8	8	13.3	21.4	3100	2200	8.35	7.52	13.0	10.0
12	8	15.1	32.4	4400	3300	12.55	11.32	19.5	15.0
16	8	16.3	42.7	5800	4400	16.75	15.12	26.0	20.0

* Attenuation of the internal cabling and the gain-decrease in case of null fill in the vertical radiation pattern are not considered.
Approximate values for gain decrease:
cable attenuation: 0.2 – 0.5 dB
null fill: 0.3 – 1.0 dB
Gain figures are valid for the direction of maximum radiation (see diagrams on following page).

** Average values, depending on design and arrangement.

*** Only according to antenna aperture H without base flange and top.

Horizontal Radiation Patterns

Examples of typical horizontal antenna arrays and their **horizontal** radiation patterns.

Omnidirectional patterns

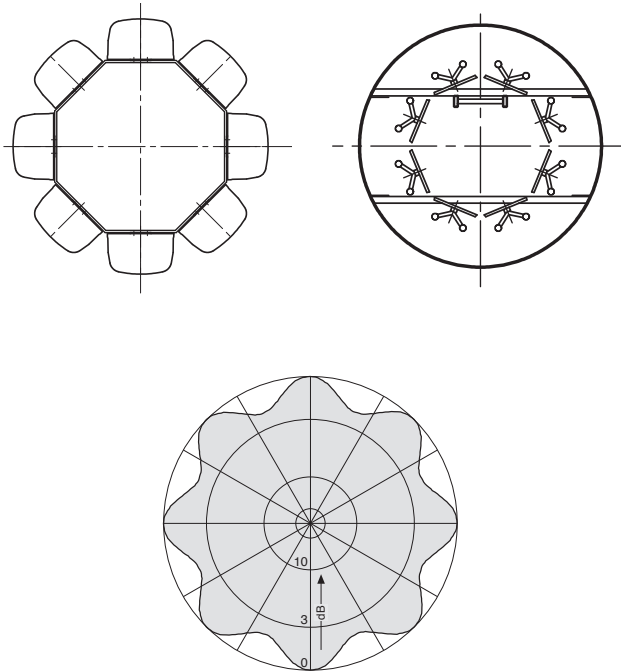

Directional patterns on request!

Vertical Radiation Patterns

Examples of typical **vertical** radiation patterns*) for several bays of identical, vertically stacked antenna arrays.

4 bays

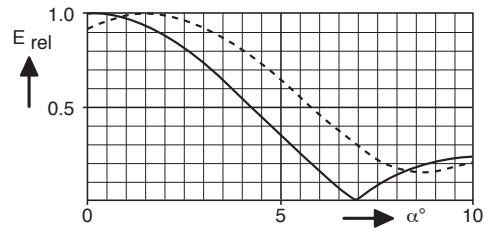

8 bays

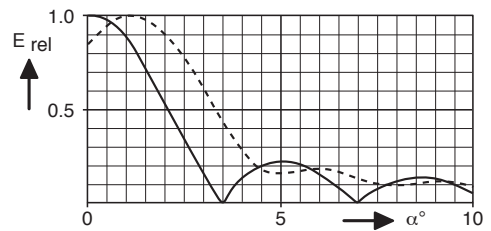

12 bays

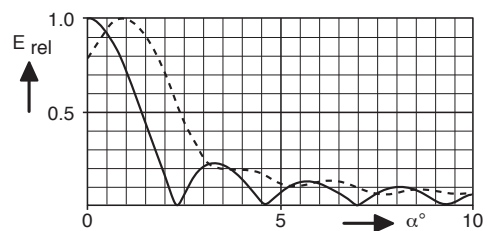

16 bays

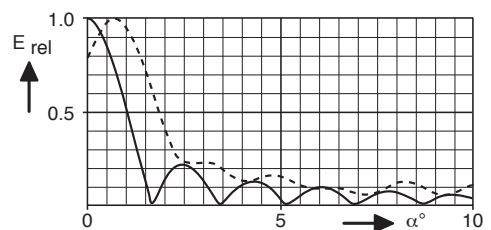

*) — without null fill
 - - - with null fill and beam tilt

Systems
470 - 862 MHz

Antennas for TV in UHF Band 470–862 MHz

Polarization

H

- All-purpose panel for mounting by fixations or to square steel spines.

Order No.	75010210	75010211	75010212	75010213
Input	7-16 female straight	7/8" EIA flange straight	13-30 female straight	1 1/2" EIA flange straight
Max. power	1.2 kW	2 kW (at 40 °C ambient temperature)	3 kW	4 kW
Frequency range	470 - 862 MHz			
VSWR	< 1.1			
Gain (at mid-band)	11.5 dBd			
Impedance	50 Ω			
Polarization	Horizontal			
Weight	8 kg	9 kg	9 kg	9 kg
Wind load (at 160 km/h)		Frontal: 565 N Rearside: 815 N Lateral: 250 N		
Max. wind velocity	225 km/h			
Attachment	Plate	Plate	Plate	Plate

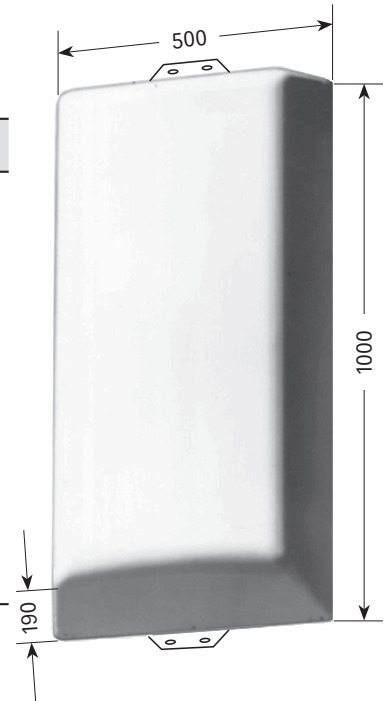

- Material:** Reflector screen and dipoles: Weather-resistant aluminum. Protective cover: Fiberglass. Attachment plate: Hot-dip galvanized steel.
- Radome color:** RAL 9016 (traffic white), other radome colors on request.
- Mounting:** Using M 8 x 35 screws (supplied) to suitable attachment construction. See chapter "Components" for optional mounting accessories (please order separately).
- Grounding:** Via mounting parts.
- Ice protection:** The dipoles remain fully functioning even in icy conditions as the fiberglass cover protects the whole antenna.



Horizontal polarization

Radiation Patterns (at mid-band)

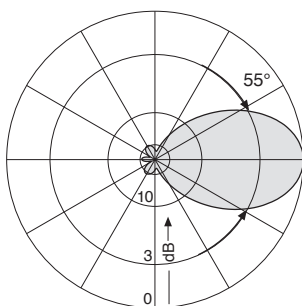

Horizontal Radiation Pattern

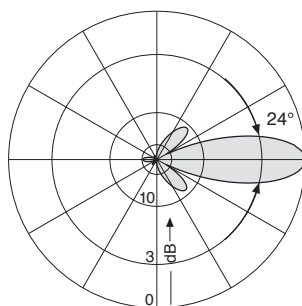

Vertical Radiation Pattern

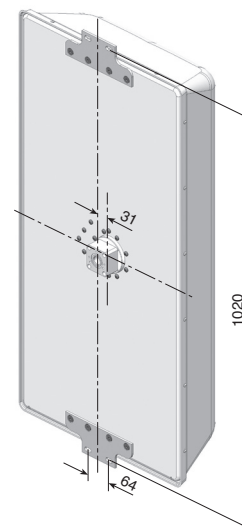

All dimensions in mm

Polarization

V

- All-purpose panel for mounting by fixations or to square steel spines.

Order No.	601709 K733147	776165	776202	776167
Input	7-16 female straight	7-16 female elbow	7/8" EIA flange elbow	13-30 female elbow
Max. power	1 kW	1 kW	1.5 kW	2 kW
Frequency range	470 – 862 MHz			
VSWR	< 1.12			
Gain (at mid-band)	11 dBd			
Impedance	50 Ω			
Polarization	Vertical			
Weight	12 kg			
Wind load (at 160 km/h)	Frontal: 565 N Rearside: 815 N Lateral: 250 N			
Max. wind velocity	240 km/h			
Attachment	Bracket	Plate	Plate	Plate

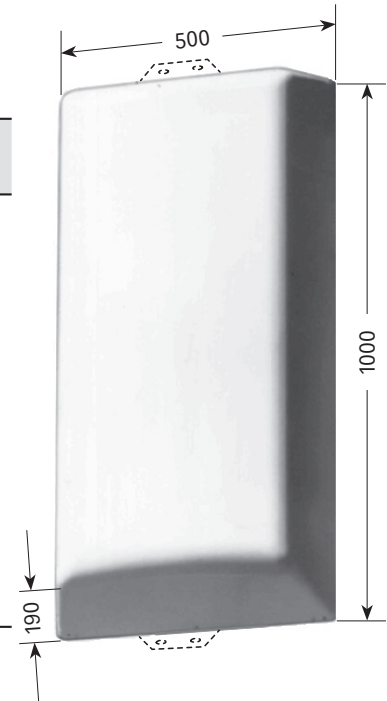

- Material:** Reflector screen and dipoles: Weather-resistant aluminum.
Protective cover: Fiberglass.
Attachment bracket: Hot-dip galvanized steel.
Attachment plate: Weather-resistant aluminum.
- Radome color:** RAL 9016 (traffic white), other radome colors on request.
- Mounting:** Attachment bracket: E.g. by using clamps 75310411–75310415 to tubular masts of 40 – 521 mm diameter.
Attachment plate: Using M 8 x 35 screws (supplied) to suitable attachment construction.
See chapter “Components” for optional mounting accessories (please order separately).
- Grounding:** Via mounting parts.
- Ice protection:** The dipoles remain fully functioning even in icy conditions as the fiberglass cover protects the whole antenna.

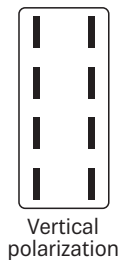

Radiation Patterns (at mid-band)

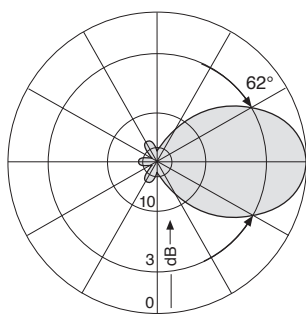

Horizontal Radiation Pattern

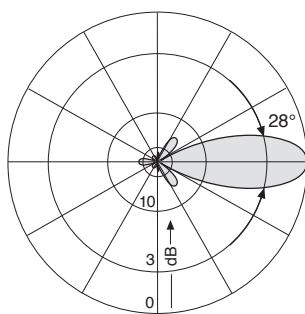

Vertical Radiation Pattern

Examples with different connectors and attachments:

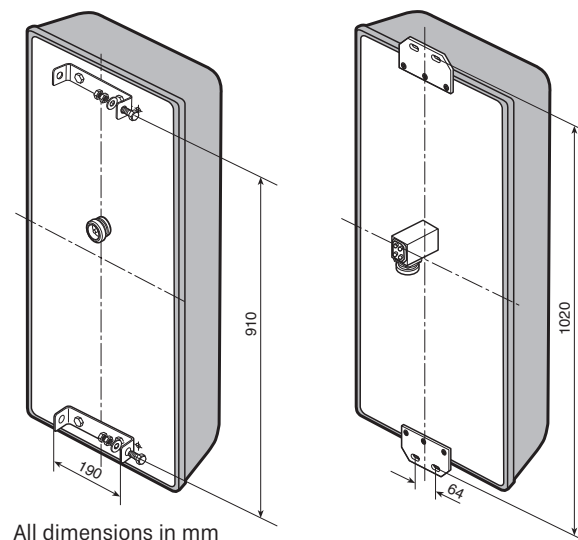

Polarization

X

- Directional antenna for elliptical polarization.

Order No.	75010325
Input	7/8" EIA flange straight
Max. power	1.5 kW (at 40 °C ambient temperature)
Frequency range	470 - 694 MHz
VSWR	< 1.15 (470-654 MHz) < 1.28 (654-694 MHz)
Gain (at mid-band)	8.5 dBd
horizontal	4.8 dBd
vertical	
Impedance	50 Ω
Polarization	Elliptical polarization with power ratio 70% horizontal / 30% vertical
Weight	16.5 kg
Wind load (at 160 km/h)	Frontal: 875 N Rearside: 1000 N Lateral: 330 N
Max. wind velocity	225 km/h
Attachment	Plate

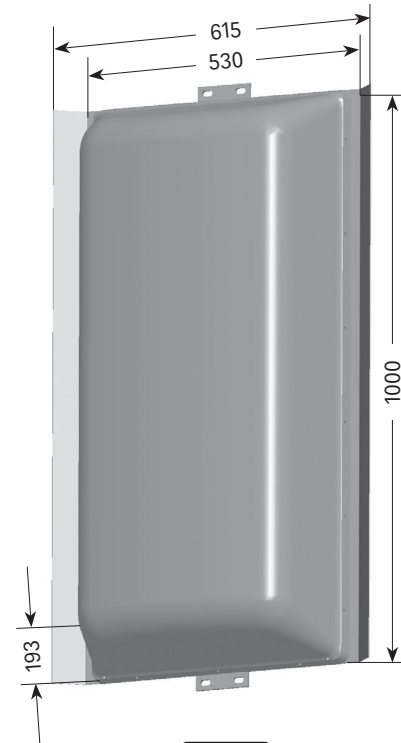

Elliptical polarization with power ratio
70% horizontal
30% vertical

- Material:** Reflector screen and dipoles: Weather-resistant aluminum, tin plated brass. Protective cover: Fiberglass. Attachment plate: Hot-dip galvanized steel.
- Radome color:** RAL 9016 (traffic white), other radome colors on request.
- Mounting:** Using M 8 x 35 screws (supplied) to suitable attachment construction. See chapter "Components" for optional mounting accessories (please order separately).
- Grounding:** Via mounting parts.
- Ice protection:** The dipoles remain fully functioning even in icy conditions as the fiberglass cover protects the whole antenna.

Radiation Patterns (at mid-band)

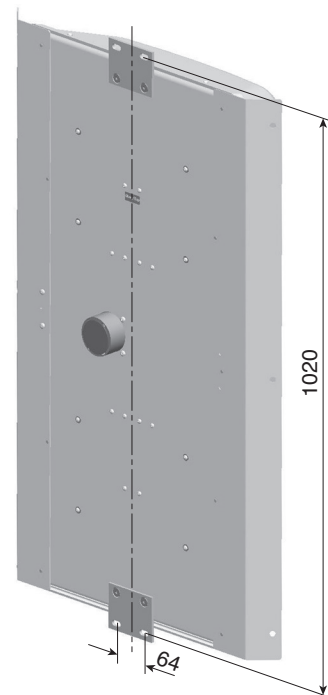
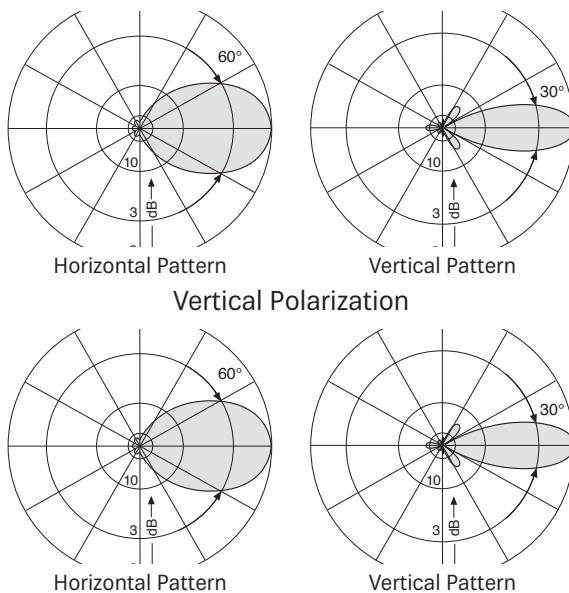

All dimensions in mm

Polarization

H V X

- Directional antenna for various polarizations.

Order No.	75010300	
Input	2 x 7-16 female straight	
Max. power	Horizontal:	1 kW
	Vertical:	1 kW
(at 40 °C ambient temperature)		
Frequency range	470 – 698 MHz	
VSWR	< 1.2	
Gain (at 650 MHz)	Horizontal:	10.5 dBd
	Vertical:	10.0 dBd
Impedance	50 Ω	
Polarization	Horizontal, vertical, circular, elliptical, slant	
Weight	16.5 kg	
Wind load (at 160 km/h)	Frontal:	920 N
	Rearside:	1050 N
	Lateral:	340 N
Max. wind velocity	225 km/h	
Attachment	Plate	

Material: Reflector screen and dipoles: Weather-resistant aluminum, tin-plated brass.
Protective cover: Fiberglass.
Attachment plate: Hot-dip galvanized steel.

Radome color: RAL 9016 (traffic white), other radome colors on request.

Mounting: Using M 8 x 35 screws (supplied) to suitable attachment construction.
Mounting dimensions upon request.
Optional mounting accessories can be ordered separately.

Grounding: Via mounting parts.

Ice protection: The dipoles remain fully functioning even in icy conditions as the fiberglass cover protects the whole antenna.

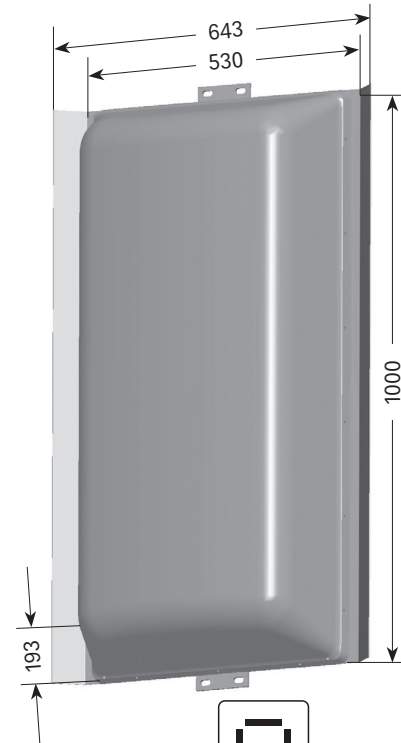

Horizontal
vertical
polarization

Radiation Patterns (at mid-band)

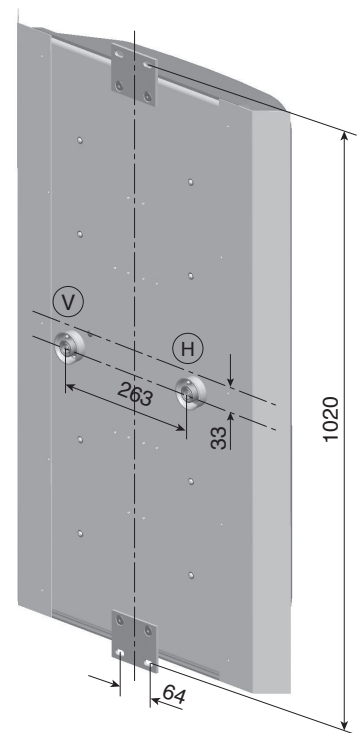
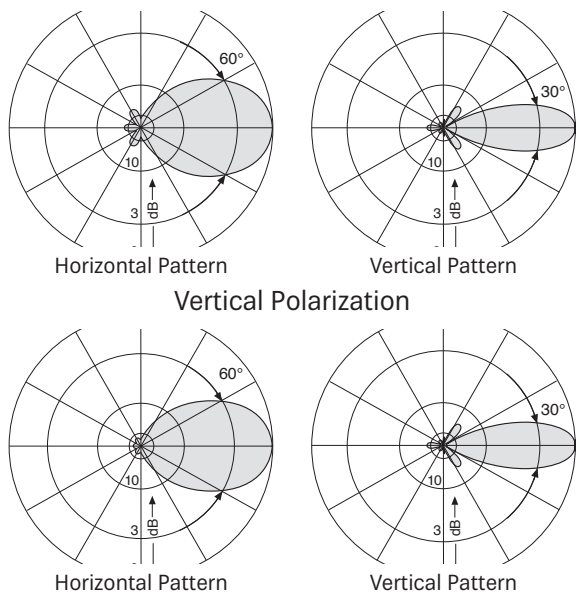

All dimensions in mm

Polarization

H V X

- Directional antenna for various polarizations.

Order No.	75010301	
Input	2 x 7/8" EIA flange straight	
Max. power	Horizontal:	2 kW
	Vertical:	1 kW
	(at 40 °C ambient temperature)	
Frequency range	470 – 698 MHz	
VSWR	< 1.2	
Gain	Horizontal:	10.5 dBd
(at 650 MHz)	Vertical:	10.0 dBd
Impedance	50 Ω	
Polarization	Horizontal, vertical, circular, elliptical, slant	
Weight	17 kg	
Wind load (at 160 km/h)	Frontal:	920 N
	Rearside:	1050 N
	Lateral:	340 N
Max. wind velocity	225 km/h	
Attachment	Plate	

Material: Reflector screen and dipoles: Weather-resistant aluminum, tin-plated brass.
Protective cover: Fiberglass.
Attachment plate: Hot-dip galvanized steel.

Radome color: RAL 9016 (traffic white), other radome colors on request.

Mounting: Using M 8 x 35 screws (supplied) to suitable attachment construction.
Mounting dimensions upon request.
Optional mounting accessories can be ordered separately.

Grounding: Via mounting parts.

Ice protection: The dipoles remain fully functioning even in icy conditions as the fiberglass cover protects the whole antenna.

Note: The polarization will be defined by the power and phase difference between H and V, created by the external feeding network.
It has to be observed that the internal feeding network of the panel creates a difference of electrical length between H and V dipoles:
Input H: 0 (reference)
Input V: +534 mm

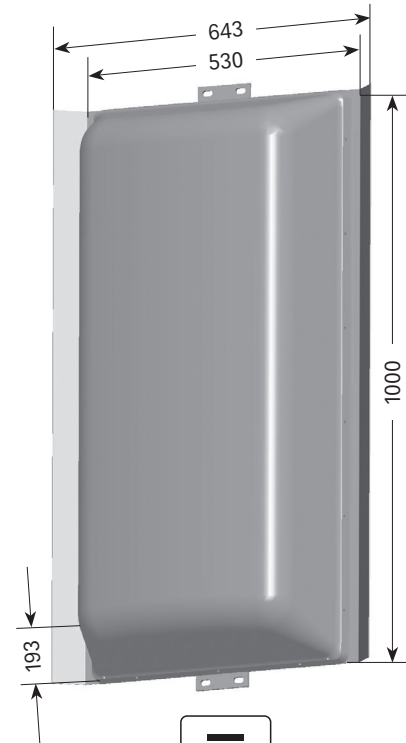

Horizontal
vertical
polarization

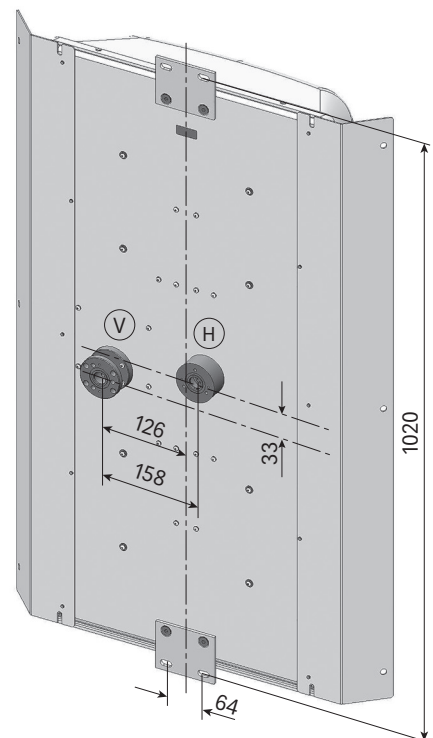

All dimensions in mm

Radiation Patterns (at mid-band)

Horizontal Polarization

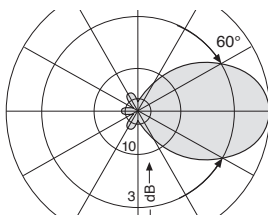

Horizontal Pattern

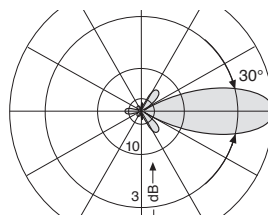

Vertical Pattern

Vertical Polarization

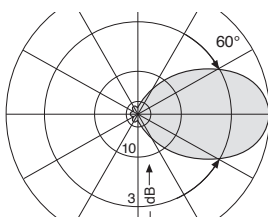

Horizontal Pattern

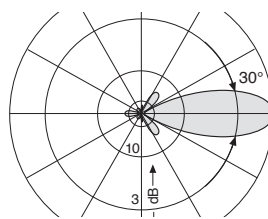

Vertical Pattern

- Directional antenna for slant polarization.

Order No.	75010329
Input	7/8" EIA flange elbow
Max. power	1.5 kW (at 40 °C ambient temperature)
Frequency range	470 – 806 MHz
VSWR	< 1.1
Gain (at mid-band)	11 dBd
Impedance	50 Ω
Polarization	Slant 80% horizontal / 20% vertical
Weight	12 kg
Wind load (at 160 km/h)	Frontal: 565 N Rearside: 815 N Lateral: 250 N
Max. wind velocity	240 km/h
Attachment	Plate

Material: Reflector screen and dipoles: Weather-resistant aluminum.
Protective cover: Fiberglass.
Attachment plate: Hot-dip galvanized steel.

Radome color: RAL 9016 (traffic white), other radome colors on request.

Mounting: Using M 8 x 35 screws (supplied) to suitable attachment construction.
See chapter "Components" for optional mounting accessories (please order separately).

Grounding: Via mounting parts.

Ice protection: The dipoles remain fully functioning even in icy conditions as the fiberglass cover protects the whole antenna.

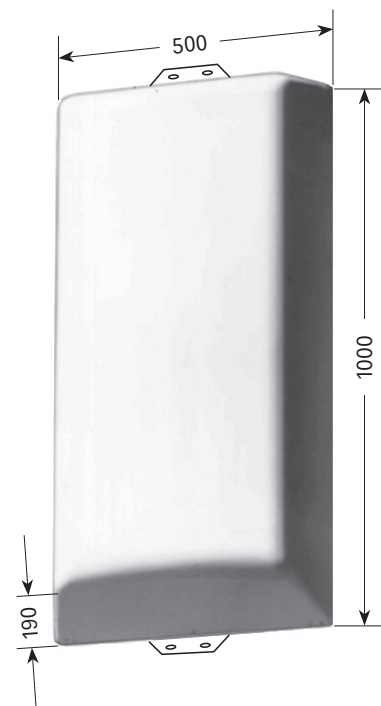

Slant 15°
Polarization ratio:
80% horizontal
20% vertical

Radiation Patterns (at mid-band)

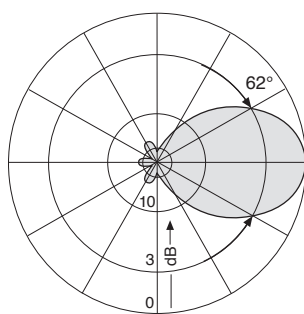

Horizontal Pattern

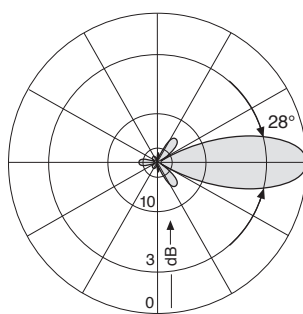

Vertical Pattern

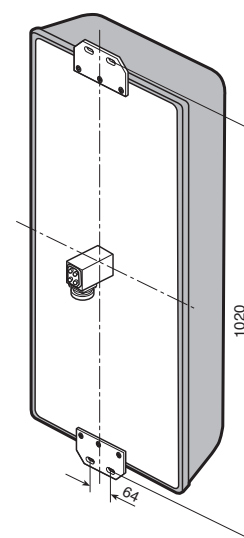

All dimensions in mm

Polarization

H

- Plug and Play Antenna fully assembled

Order No.	75010402
Input	1½" EIA flange
Max. power	5 kW (at 40 °C ambient temperature)
Frequency range	470 – 790 MHz
VSWR	≤ 1.15 ≤ 1.1 in one channel after fine matching*
Gain (at 650 MHz)	10 dBd
Impedance	50 Ω
Polarization	Horizontal
Weight (approx.)	52 kg
Wind load (at 160 km/h (approx.))	Frontal: 1.1 kN Rearside: 1.3 kN Lateral: 0.6 kN
Max. wind velocity	275 km/h

* fine matcher to be ordered separately

Material: Radiator system: Weather-resistant aluminum.
Protective cover: Fiberglass.
Attachment plate: Hot-dip galvanized steel.

Radome color: Light grey (RAL 7035).

Mounting: Side mounting to tubular mast by clamp
(for Ø 42-115 mm supplied, for larger Ø please order separately).

Grounding: Via mounting parts.

Ice protection: The radiators remain fully functioning even in icy conditions as the fiberglass cover protects the whole antenna.



Typical Radiation Patterns at 600 MHz

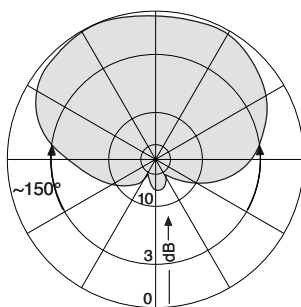

Horizontal Pattern

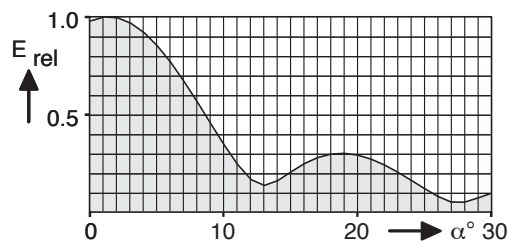

Vertical Pattern

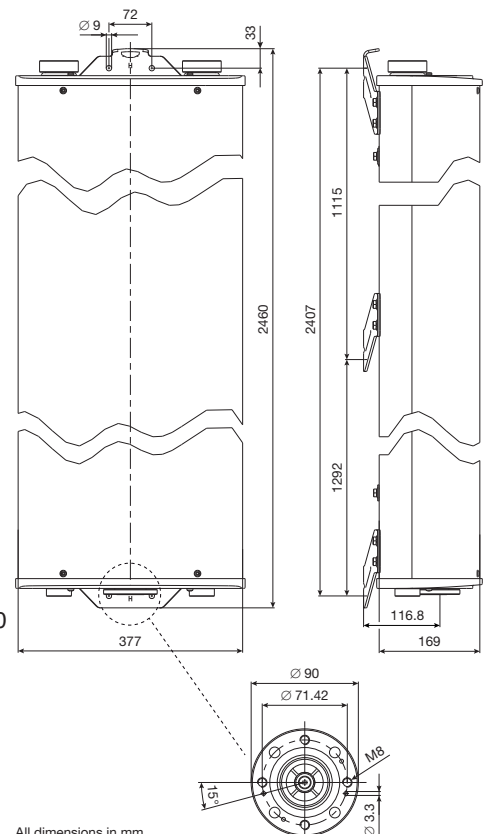

All dimensions in mm

Polarization

X

New product

- UHF Panel Frame Antenna in radome, elliptically polarized.
- Broadband 470–608 MHz.
- Low wind load.
- HRP can be defined by attached power splitter.

Order No.	750000041		
Input Connector position	6½" EIA flange bottom		
Max. power	25 kW		
Frequency range	470 – 608 MHz		
VSWR	< 1.15 (typical)		
Nominal peak gain (at mid-band)	Pattern: Omni	Pattern: Omnioid "G"	Pattern: Cardioid "D"
Hpol portion:	10.2 dBd	10.9 dBd	11.4 dBd
Vpol portion:	6.6 dBd	7.0 dBd	7.3 dBd
Average gain (at mid-band)			
Hpol portion:	9.3 dBd	–	–
Vpol portion:	5.6 dBd		
Impedance	50 Ω		
Polarization	Elliptical with a power ratio of 70% horizontal / 30% vertical		
Approx. weight	700 kg		
Approx. wind load (at 160 km/h)	4100 N		
Max. wind velocity	240 km/h		
Approx. height	7 m		



Material: Directional antenna in protective fiberglass radome with a diameter of 800 mm. Radome color: light grey (RAL 7035), other colors on request. Please specify when ordering.

Mounting: Sidemount to existing structure.

Grounding: Via mounting parts.

Typical Radiation Patterns (at mid-band)

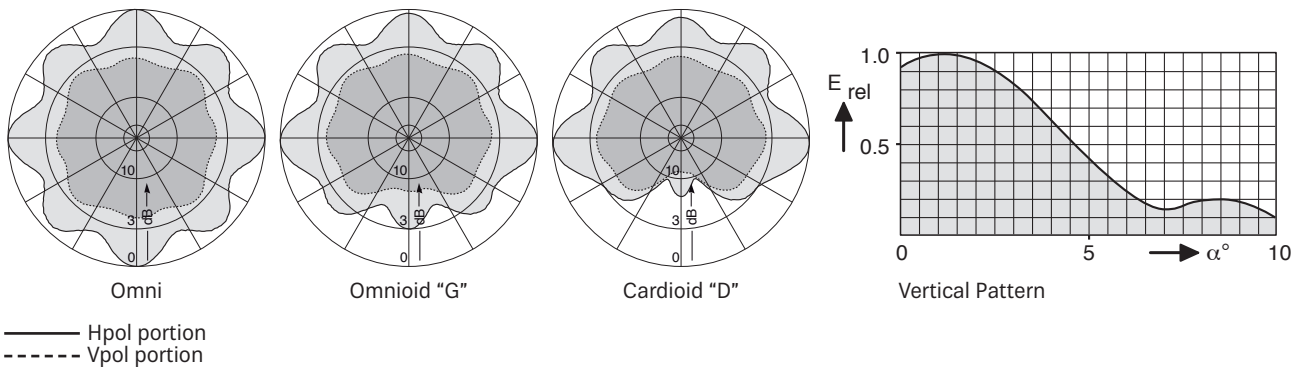

Polarization

H

- UHF Panel Frame Antenna in radome, fully assembled.
- Broadband 470–698 MHz.
- High power.
- Low wind load.
- Wide cardioid pattern.

Order No.	75010421
Input Connector position	6½" EIA flange center
Max. power	60 kW
Frequency range	470 – 698 MHz
VSWR	< 1.1 (typical)
Gain (at mid-band)	15 dBd
Impedance	50 Ω
Polarization	Horizontal
Approx. weight	860 kg
Approx. wind load (at 160 km/h)	5400 N
Max. wind velocity	240 km/h
Approx. height	9.2 m

Material: Directional antenna in protective fiberglass radome with a diameter of 800 mm.
Radome color: light grey (RAL 7035), other colors on request. Please specify when ordering.

Mounting: Sidemount to existing structure.

Grounding: Via mounting parts.



Typical Radiation Patterns (at mid-band)

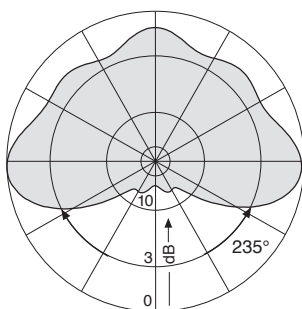

Horizontal Pattern

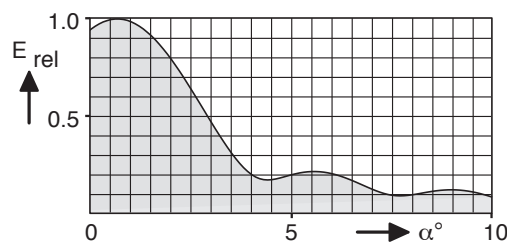

Vertical Pattern

Polarization

H

V

- High side-lobe suppression.

Order No.	75010393
Input	7-16 female
Max. power	500 W (at 40 °C ambient temperature)
Frequency range	470 – 862 MHz
VSWR	< 1.25
Gain	9.0 dBd at mid-band
Side-lobe suppression	> 23 dB at 470 – 500 MHz > 25 dB at 500 – 860 MHz
Impedance	50 Ω
Polarization	Either horizontal or vertical by repositioning two clamps
Weight	9 kg
Wind load (at 160 km/h)	Frontal / lateral: 63 / 100 N Frontal / lateral: 63 / 500 N
Max. wind velocity	For horizontal pol.: 240 km/h For vertical pol.: 180 km/h

- Material:** Radiator: Weather-resistant aluminum.
Radome: Fiberglass, color: Grey.
Mounting kit: Weather-resistant aluminum.
All screws and nuts: Stainless steel.
- Mounting:** To tubular masts of 48-115 mm diameter using supplied clamps.
- Grounding:** Via mounting parts.
- Ice protection:** Since radiating system is fully protected by the radome and due to its very sturdy construction, the antenna remains fully operational even under heavy icy conditions.

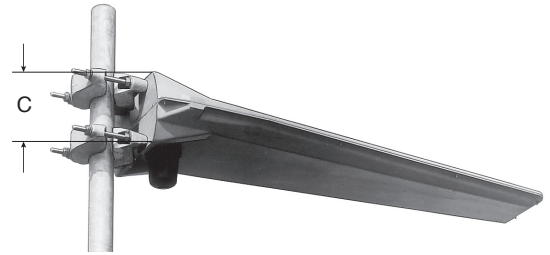

For horizontal polarization

A: ~ 1153 mm
B: ~ 353 mm
C: ~ 180 mm

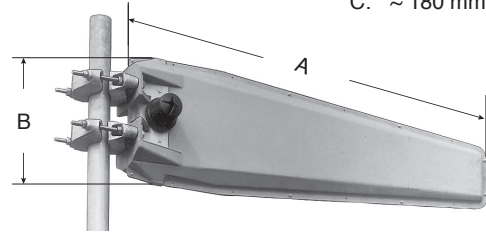

For vertical polarization

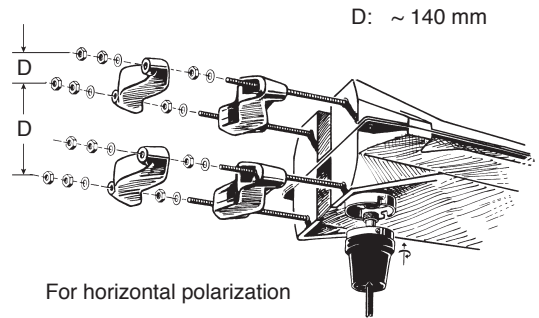

For horizontal polarization

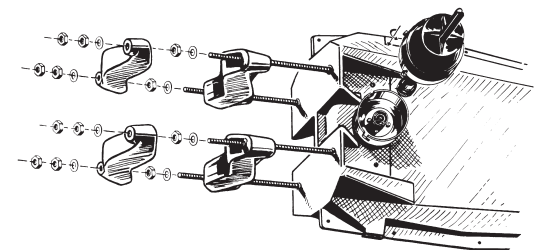

For vertical polarization

Radiation Patterns (at mid-band)

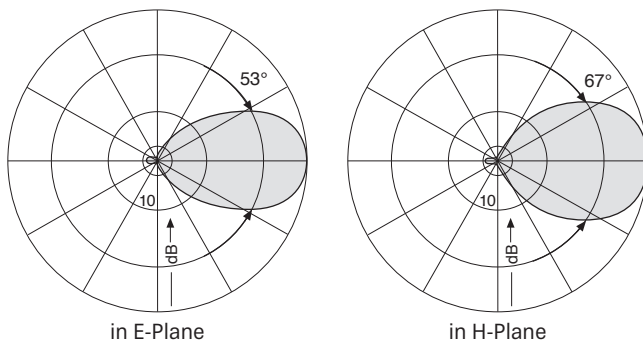

Polarization

H

- Low power Superturnstile antennas
- Plug and Play Antennas fully assembled
- Low wind load and low weight
- Horizontal polarization

Material: Omnidirectional antenna in protective fiberglass radome with a diameter of 230 mm.
 Radome color: Light grey (RAL 7035).
 Flange: Hot-dip galvanized steel (antenna 75010270: aluminum)

Attachment: Onto a fitting counterflange or to tubular masts by using a steel adapter.
 See chapter “Components” for optional mounting accessories (to be ordered separately).

Grounding: Via mounting parts. Antenna interior is fully conductive from top cover to bottom flange.



Order No.	75010270	75010271	75010272
Input connector	7-16 female	7-16 female	7-16 female
Max. power*	600 W	1 kW	1 kW
Frequency range	470 – 862 MHz	470 – 862 MHz	470 – 862 MHz
VSWR	≤ 1.2	≤ 1.2	≤ 1.15
Gain (at mid-band)	2.0 dBd	4.5 dBd	7.5 dBd
Impedance	50 Ω	50 Ω	50 Ω
Radome diameter	230 mm	230 mm	230 mm
Height (approx.)	0.8 m	1.3 m	2.2 m
Weight	13 kg	16 kg	24 kg
Wind load (at 160 km/h)	110 N	195 N	350 N
Max. wind velocity	240 km/h	240 km/h	240 km/h

* at 40 °C ambient temperature

Horizontal Radiation Pattern
(at mid-band)

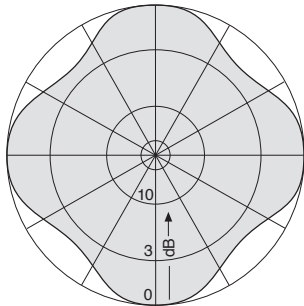

Typical Horizontal Radiation Pattern

Vertical Radiation Patterns
(at mid-band)

75010270

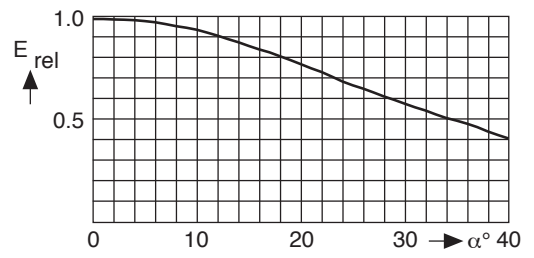

75010271

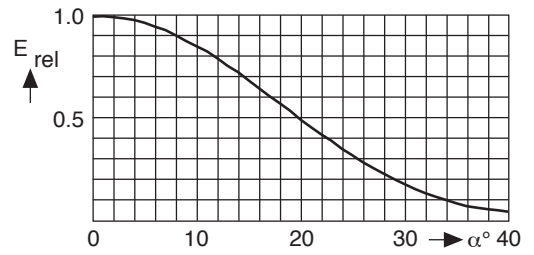

75010272

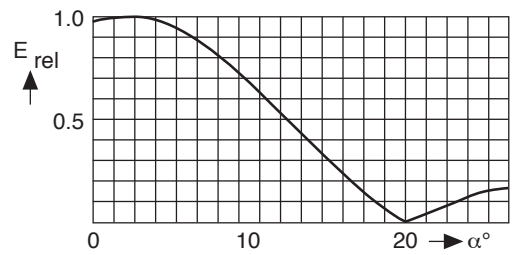

Polarization

H

- Medium and high power Superturnstile antennas
- Plug and Play Antennas fully assembled
- Low wind load and low weight
- Horizontal polarization

Material: Omnidirectional antenna in protective fiberglass radome.
Radome color: Light grey or customized.
Flange: Hot-dip galvanized steel.

Attachment: Onto a fitting counterflange or to tubular masts by using a steel adapter.
See chapter “Components” for optional mounting accessories (to be ordered separately).

Grounding: Via mounting parts.

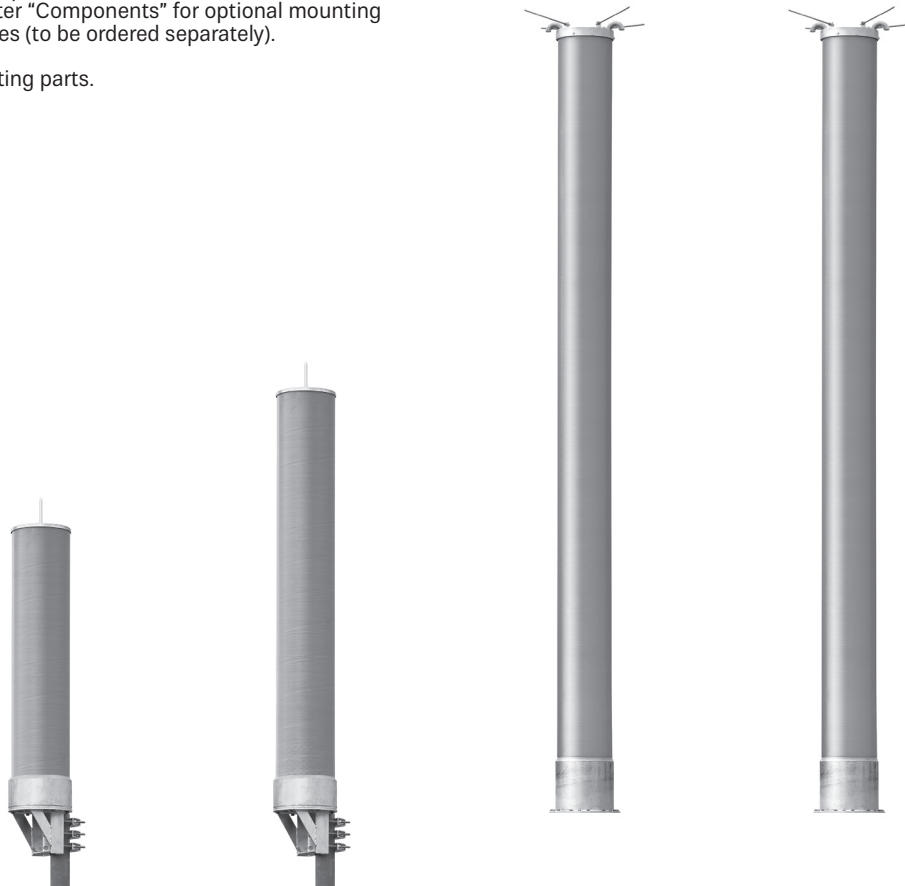

Order No.	75010066	75010067	75010068	75010069
Input connector	1½" EIA flange	1½" EIA flange	1½" EIA flange	3½" EIA flange
Max. power*	2.5 kW	5 kW	5 kW	7.5 kW
Frequency range	470 – 862 MHz	470 – 862 MHz	470 – 862 MHz	470 – 862 MHz
VSWR	≤ 1.1	≤ 1.1	≤ 1.1	≤ 1.1
Gain (at mid-band)	5.0 dBd	8.0 dBd	11.0 dBd	11.0 dBd
Impedance	50 Ω	50 Ω	50 Ω	50 Ω
Radome diameter	330 mm	330 mm	330 mm	330 mm
Height (approx.)	1.4 m	2.4 m	4.8 m	4.8 m
Weight	45 kg	70 kg	140 kg	145 kg
Wind load (at 160 km/h)	330 N	590 N	1200 N	1200 N
Max. wind velocity	240 km/h	240 km/h	240 km/h	240 km/h

* at 40 °C ambient temperature

All gain figures without null fill and beam tilt losses

UHF Omni Polarization

470–862 MHz

KATHREIN

H

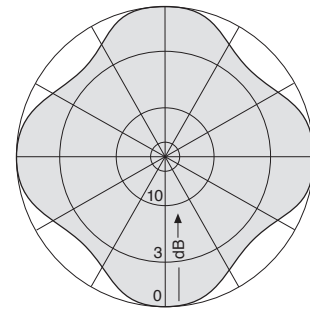

Typical Horizontal Radiation Pattern

Vertical Radiation Patterns
(at mid-band)
Examples of typical **vertical**
radiation patterns*)

75010066

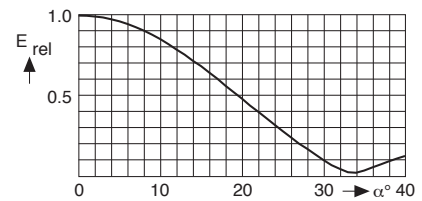

75010067

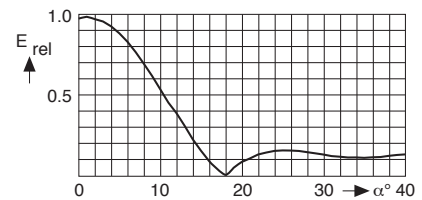

75010068 / 75010069

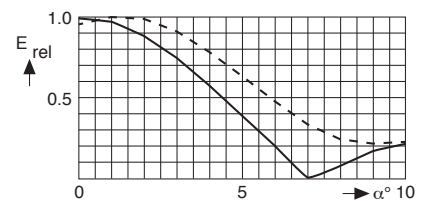

75010180

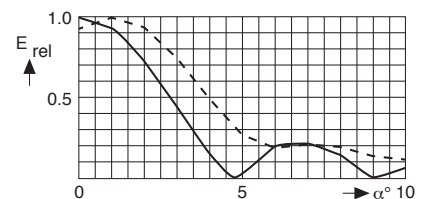

*) ——— without null fill
- - - - with null fill and beam tilt

Order No.	75010180
Input connector	3 1/8" EIA flange
Max. power*	15 kW
Frequency range	470 – 862 MHz
VSWR	≤ 1.1
Gain (at mid-band)	12.0 dBd
Impedance	50 Ω
Radome diameter	520 mm
Height	7.5 m
Weight	650 kg
Wind load (at 160 km/h)	4500 N
Max. wind velocity	240 km/h

* at 40 °C ambient temperature
Gain figure without null fill
and beam tilt losses

Available options for 75010180:
Hook-in ladder
Aviation warning light

Power Splitters

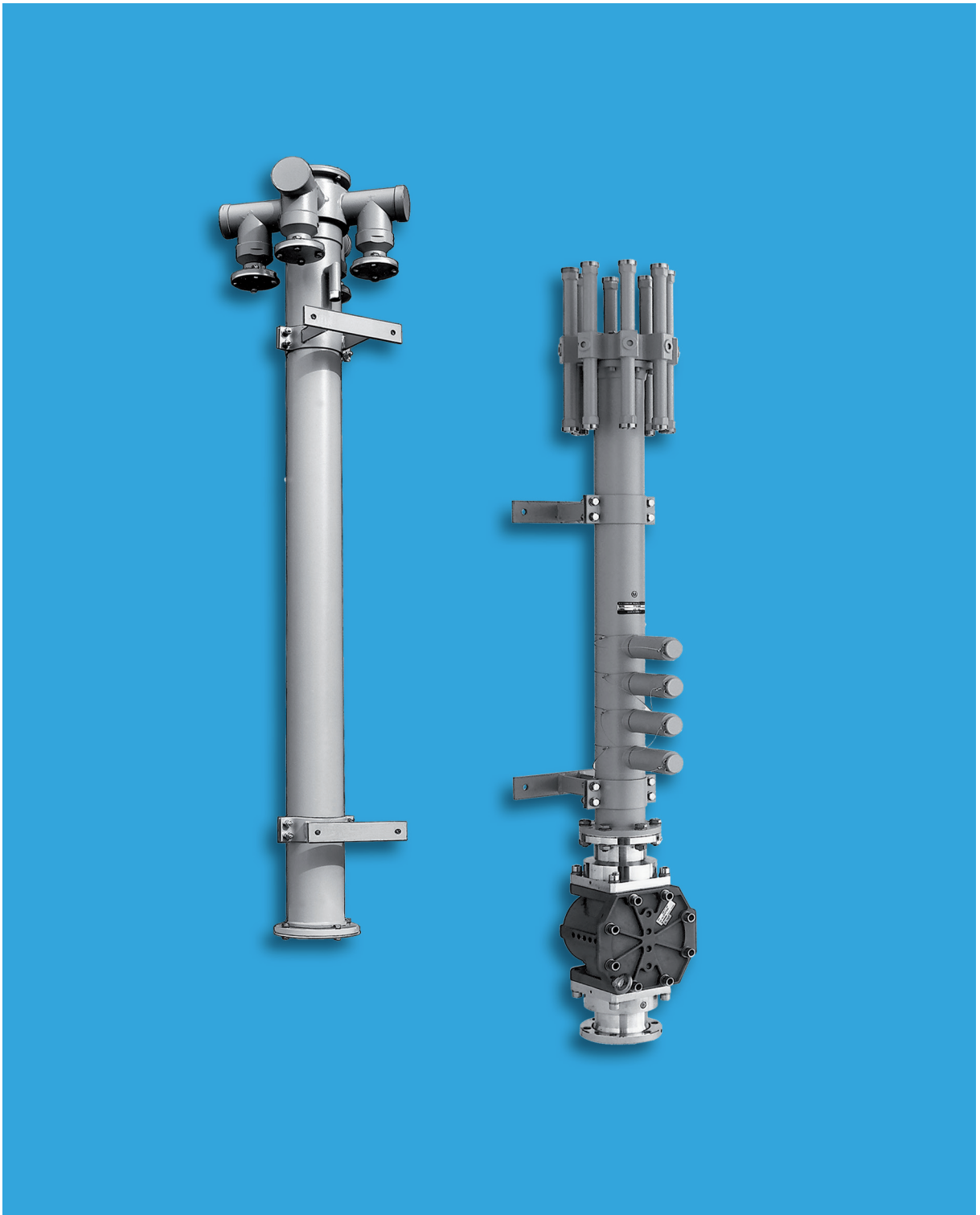

High Power Splitters

47 ... 88 MHz, 87.5 – 108 MHz, 174 – 230 (240) MHz, 470 – 862 MHz

KATHREIN

- Various versions with different numbers of output and different splitting ratios are available.

Frequency range	47 ... 88 MHz	87.5 – 108 MHz	174 – 230 (240) MHz	470 – 862 MHz
Length approx. with tuning unit approx.	2400 mm 2600 mm	1700 mm –	850 mm 1500 mm	700 mm 1000 mm
Input power	1 – 200 kW	1 – 200 kW	1 – 150 kW	1 – 70 kW
Connectors	7-16, 13-30, 7/8", 15/8", 31/8", 41/2", 61/8" EIA flange (or other connectors upon request)			
Impedance	50 Ω			
Insertion loss	< 0.05 dB			
Number of outputs	2 to 16			
VSWR equal power ratio	< 1.05 in frequency range			
VSWR unequal power ratio	< 1.06 in frequency range			
Fine matching	On request, the power splitter can be equipped with a tuning section, which allows fine matching of parts of the frequency band.			
Splitting power ratio	Equal or unequal, on request.			

- Material:** Outer conductor: Brass with protective grey paint.
Inner conductor: Brass or aluminum.
- Mounting:** On flat surfaces using the standard mounting equipment consisting of 2 bracket arms (supplied) or steel frame (please order separately).
- Pressurization:** The pressurization-tight transformer housing has a ventilation tube to balance out excess pressure.
For pressurized operation (typically at 300 mbar) this ventilation tube must be closed with the supplied sealing screw.
IP 65 (closed ventilation tube for pressurized operation)
IP 53 (opened ventilation tube for non-pressurized operation)



Example:
Tunable 16-way splitter with unequal power splitting and with a measuring link.



Example:
4-way splitter with standard-attachment.

Medium Power Splitters

47 ... 88 MHz, 87.5 – 108 MHz, 174 – 230 (240) MHz, 470 – 862 MHz

KATHREIN

- Various versions with different numbers of output and different splitting ratios are available.

Frequency range	47 ... 88 MHz	87.5 – 108 MHz	174 – 230 (240) MHz	470 – 862 MHz
Length approx. with tuning unit approx.	2400 mm 2600 mm	1650 mm –	845 mm 1500 mm	560 mm 860 mm
Input power	3 kW	2.5 kW	2 kW	1 kW
Connectors	7-16 female (other connectors upon request)			
Impedance	50 Ω			
Insertion loss	< 0.05 dB			
Number of outputs:	2 to 12			
VSWR equal power ratio:	< 1.05 in frequency range			
VSWR unequal power ratio:	< 1.06 in frequency range			
Fine matching:	On request, the power splitter can be equipped with a tuning section, which allows fine matching of parts of the frequency band.			
Splitting power ratio:	Equal or unequal, on request.			

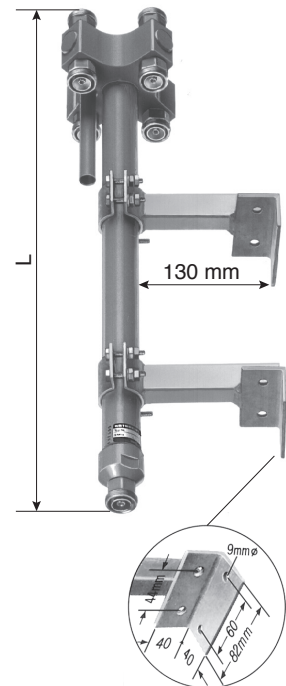

- Material:** Outer conductor: Brass with protective grey paint.
Inner conductor: Brass or aluminum.
- Mounting:** On flat surfaces using the standard mounting equipment supplied (Bracket arm, 130 mm). To tubes of 30 – 340 mm diameter by means of 2 tension band clamps Type No. 759044 (please order separately).
- Pressurization:** The pressurization-tight transformer housing has a ventilation tube to balance out excess pressure. For pressurized operation (typically at 300 mbar) this ventilation tube must be closed with the supplied sealing screw. IP 65 (closed ventilation tube for pressurized operation)
IP 53 (opened ventilation tube for non-pressurized operation)

759044

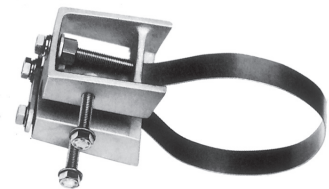

Number of outputs	Order No. of available power splitters - without tuning unit						- with tuning unit	
	47 – 54 MHz	54 – 61 MHz	60 – 68 MHz	87.5 – 108 MHz	174 – 230 MHz	470 – 862 MHz	174 – 230 MHz	470 – 862 MHz
2	765814	765814	765814	770144	770510*	764485	770516*	764493
3	765815	765820	765825	770145	770511*	764486	770517	764494
4	765816	765821	765826	770146	770512	764487	770518	764495
4					75111062*		75111063*	
5				770147	770513*	764488	770519*	764496
6	765818	765823	765828	770148	770514*	764489	770520*	764497
8	765819	765824	765829	770149	770515*	764491	770521*	764499

* up to 240 MHz

Low Power Splitters

KATHREIN

174 – 230 MHz

470 – 862 MHz

174 – 230 MHz

Order No.	768334	768335	768336
Connector	7-16 female		
Max. power (at 50 °C ambient temp.)	2 kW		
Number of outputs	2	3	4
Frequency range	174 – 230 MHz		
Impedance	50 Ω		
VSWR	< 1.07		
Insertion loss	< 0.05 dB		
Max. size	800 / 82 / 82 mm		

470 – 862 MHz

Order No.	768331	768332	768333
Connector	7-16 female		
Max. power (at 50 °C ambient temp.)	1 kW		
Number of outputs	2	3	4
Frequency range	470 – 862 MHz		
Impedance	50 Ω		
VSWR	< 1.07		
Insertion loss	< 0.05 dB		
Max. size	520 / 82 / 82 mm		

Material: Case: Aluminum.
Inner conductor: Brass.

Mounting: Bracket included for wall mounting.
May be attached to tubular masts using clamps listed below (please order separately).



768332

Order No.	Description	Remarks
753000010	2 clamps	Mast diameter: 45–125 mm



Combiners and Filters for FM Broadcast



Band-pass Filter

87.5 ... 108 MHz, 100 W

KATHREIN

Band-pass filter can be used

- for improving the input selectivity of receivers and amplifiers
- for increasing the isolation of transmitters where respective antennas are close together
- for suppressing noise side bands and intermodulation products
- as a component in the construction of combiners

Design and Construction

The band-pass filter is made of three capacitively coupled resonators. The operating frequency, the coupling between the resonators and also the input and output couplings are adjustable.

The band-pass filter is convection-cooled, no ventilators are required.

The band-pass filter must be tuned to the operating channel. Tuning may be done at our factory or can be carried out on site.

Clear tuning instructions and also any special tools necessary are part of the delivery extent.

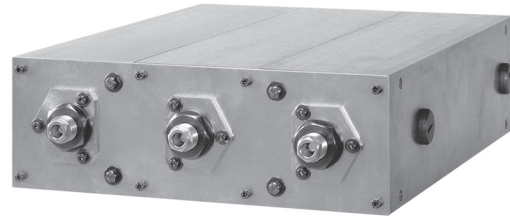

719118 FM Band-pass filter, 100 W

Technical Data

Type No.	719118
Frequency range	87.5 ... 108 MHz
Insertion loss ⁽¹⁾	< 0.7 dB
VSWR	< 1.1 (at pass band)
Impedance	50 Ω
Input power	max. 100 W
Temperature range	-20 °C ... +50 °C
Connectors	7-16 female
Material	Aluminium (outer conductor) Brass, silver-plated (inner conductor)
Weight	12 kg
Dimensions (l x w x h)	460 x 312 x 100 mm
Packing size (l x w x h)	550 x 360 x 160 mm

⁽¹⁾ Insertion loss value apply to standard tuning with 3-dB bandwidth of about 1.250 kHz.

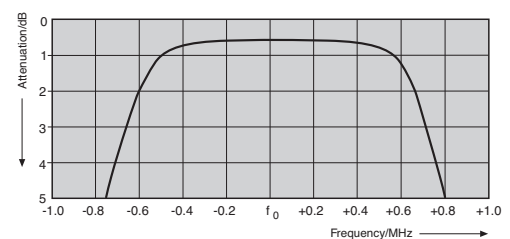
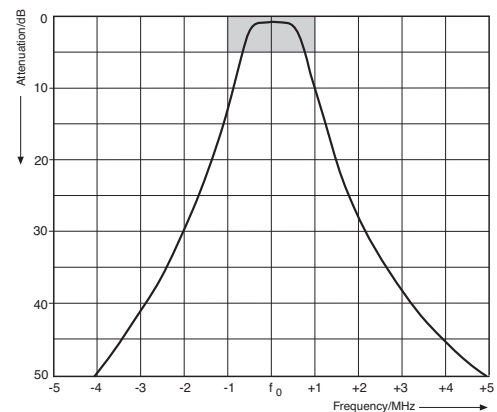

Band-pass Filter

87.5 ... 108 MHz, 3 kW

KATHREIN

Band-pass filter can be used

- for improving the input selectivity of receivers and amplifiers
- for increasing the isolation of transmitters whose respective antennas are close together
- for suppressing noise side bands and intermodulation products
- as a component in the construction of combiners

Design and Construction

The band-pass filter is made of three capacitively coupled, temperature stabilised resonators. The operating frequency, the coupling between the resonators and also the input and output couplings are adjustable.

Any heat produced is dissipated into the surroundings via heat sinks. The band-pass filter is convection-cooled, so no ventilators are required.

The band-pass filter must be tuned to the operating channel. Tuning may be done at our factory or can be carried out on site.

Clear tuning instructions and also any special tools necessary are part of the delivery extent.



728726 FM Band-pass filter, 3 kW

Technical Data

Type No.	728726
Frequency range	87.5 ... 108 MHz
Insertion loss ⁽¹⁾	< 0.25 ... 0.5 dB
VSWR	< 1.1 (at pass band)
Impedance	50 Ω
Input power	max. 3 kW
Temperature range	-20 °C ... +50 °C
Connectors	7/8" EIA-flange
Material	Aluminium (outer conductor) Brass, silver-plated (inner conductor)
Colour	RAL 7032 (grey)
Weight	55 kg
Dimensions (l x w x h)	680 x 220 x 1320 mm
Packing size (l x w x h)	720 x 300 x 1500 mm

⁽¹⁾ Insertion loss value with standard tuning will be approx. 0.35 dB; reference 3-dB bandwidth is 900 kHz.

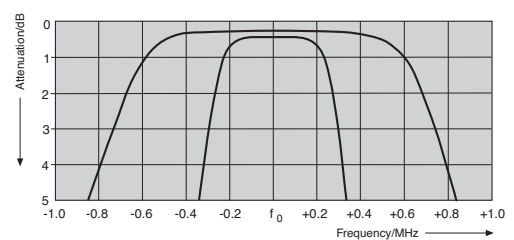
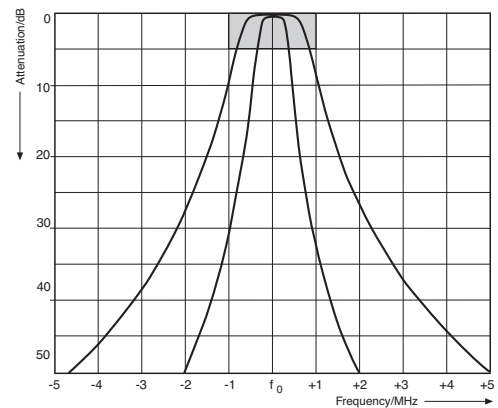

Band-pass Filter

87.5 ... 108 MHz, 5 kW

KATHREIN

Band-pass filter can be used

- for improving the input selectivity of receivers and amplifiers
- for increasing the isolation of transmitters whose respective antennas are close together
- for suppressing noise side bands and intermodulation products
- as a component in the construction of combiners

Design and Construction

The band-pass filter is made of three capacitively coupled, temperature stabilised resonators. The operating frequency, the coupling between the resonators and also the input and output couplings are adjustable.

Any heat produced is dissipated into the surroundings via heat sinks. The band-pass filter is convection-cooled, so no ventilators are required.

The band-pass filter must be tuned to the operating channel. Tuning may be done at our factory or can be carried out on site.

Clear tuning instructions and also any special tools necessary are part of the delivery extent.



730150 FM Band-pass filter, 5 kW

Technical Data

Type No.	730150
Frequency range	87.5 ... 108 MHz
Insertion loss ⁽¹⁾	< 0.25 ... 0.4 dB
VSWR	< 1.1 (at pass band)
Impedance	50 Ω
Input power	max. 5 kW
Temperature range	-20 °C ... +50 °C
Connectors	1½" EIA-flange
Material	Aluminium (outer conductor) Brass, silver-plated (inner conductor)
Colour	RAL 7032 (grey)
Weight	100 kg
Dimensions (l x w x h)	975 x 285 x 1260 mm
Packing size (l x w x h)	1100 x 470 x 1450 mm

⁽¹⁾ Insertion loss value with standard tuning will be approx. 0.30 dB; reference 3-dB bandwidth is 800 kHz.

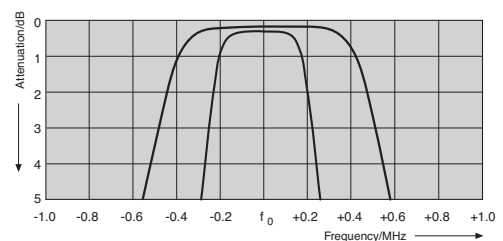
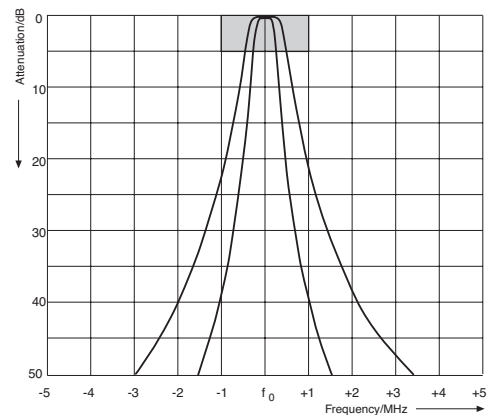

Starpoint Combiner

87.5 ... 108 MHz, 100 W

KATHREIN

General

Starpoint combiners enable several transmitters or receivers to be connected to one common output. This arrangement provides a cost-efficient solution while retaining the advantages of band-pass filter usage.

Design and Construction

This starpoint combiners consist of one 3-pole band-pass filter per channel. The inputs of the filters are narrowband. The outputs are connected via pre-defined cable lengths to a common starpoint. This starpoint then forms the output of the combiner.

The starpoint combiners may be extended by adding further band-pass filters and by exchanging the starpoint.

The combiners are maintenance-free and are thus especially safe to operate.

The band-pass filters must be tuned to the operating channel. Tuning may be done at our factory or can be carried out on site.

Clear tuning instructions and also any special tools necessary are supplied along with the combiner.



793196 FM Starpoint combiner, 4x 100 W

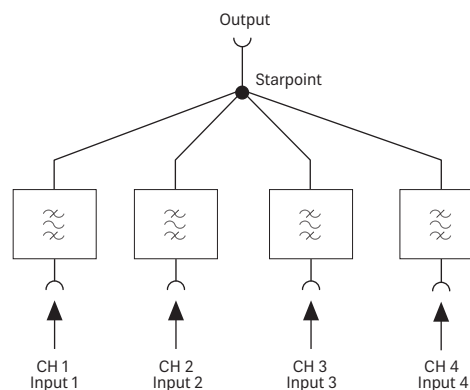

Technical Data

Type No.	Inputs	Insertion loss ¹	Connectors Input / Output	Weight	Height ²	Packing size [mm]
793192	2	< 0.9 dB	7-16 female	31 kg	8 HU	650 x 590 x 450
793194	3	< 0.9 dB	7-16 female	43 kg	8 HU	650 x 590 x 450
793196	4	< 1.0 dB	7-16 female	55 kg	12 HU	650 x 590 x 630
Frequency range	87.5 ... 108 MHz					
Channel spacing	> 2 MHz					
Isolation	> 30 dB					
VSWR	< 1.1 (at pass band)					
Impedance	50 Ω					
Input power	max. 100 W (per input)					
Temperature range	-20 °C ... +50 °C					
Material	Aluminium (outer conductor) Brass, silver-plated (inner conductor)					
Colour (front plate)	RAL 7032 (grey)					
Dimensions	19" drawer (depth 550 mm)					

¹ Insertion loss value refers to a 3-dB bandwidth of 1.250 kHz. Minimum 3-dB bandwidth is 1000 kHz.

² One HU (height unit) is equivalent to 44.45 mm

Starpoint Combiner

87.5 ... 108 MHz, 3 kW

KATHREIN

General

Starpoint combiners enable several transmitters or receivers to be connected to one common output. This arrangement provides a cost efficient solution while retaining the advantages of band-pass filter usage.

Design and Construction

This starpoint combiners consist of one temperature stabilised 3-pole band-pass filter per channel. The inputs of the filters are narrowband. The outputs are connected via pre-defined rigid-lines onto a common starpoint. This starpoint then forms the output of the combiner.

The starpoint combiners may be extended by adding further band-pass filters and by exchanging the starpoint.

Any heat produced is dissipated into the surroundings via heat sinks. The starpoint combiner is convection-cooled, so no ventilators are required.

The band-pass filters must be tuned to the operating channel. Tuning may be done at our factory or can be carried out on site.

Clear tuning instructions and also any special tools necessary are supplied along with the combiner.



728868 FM Starpoint combiner, 2x 3 kW

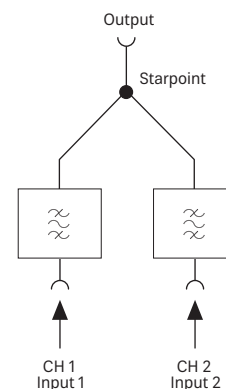

Technical Data

Type No.	Inputs	Insertion loss ⁽¹⁾	Connectors Input / Output	Weight	Dimensions (l x w x h) [mm]	Packing size [mm]
728868	2	< 0.5 dB	7/8" EIA / 1 1/8" EIA	110 kg	790 x 482 x 1320	1010 x 610 x 1400
730040	3	< 0.6 dB	7/8" EIA / 1 1/8" EIA	180 kg	1553 x 482 x 1320	1x 1010 x 610 x 1400 1x 1010 x 315 x 1400
730041	4	< 0.7 dB	7/8" EIA / 1 1/8" EIA	250 kg	1553 x 482 x 1320	2x 1010 x 610 x 1400
Frequency range				87.5 ... 108 MHz		
Channel spacing				> 1.5 MHz		
Isolation				> 30 dB		
VSWR				< 1.1 (at pass band)		
Impedance				50 Ω		
Input power				max. 3 kW (per input)		
Temperature range				-20 °C ... +50 °C		
Material				Aluminium (outer conductor) Brass, silver-plated (inner conductor)		
Colour				RAL 7032 (grey)		

⁽¹⁾ Insertion loss value refers to a 3-dB bandwidth of 900 kHz. Minimum 3-dB bandwidth is 600 kHz.

Starpoint Combiner

87.5 ... 108 MHz, 5 kW

KATHREIN

General

Starpoint combiners enable several transmitters or receivers to be connected to one common output. This arrangement provides a cost efficient solution while retaining the advantages of band-pass filter usage.

Design and Construction

This starpoint combiners consist of one temperature stabilised 3-pole band-pass filter per channel. The inputs of the filters are narrowband. The outputs are connected via pre-defined rigid-lines onto a common starpoint. This starpoint then forms the output of the combiner.

The starpoint combiners may be extended by adding further band-pass filters and by exchanging the starpoint.

Any heat produced is dissipated into the surroundings via heat sinks. The starpoint combiner is convection-cooled, so no ventilators are required.

The band-pass filters must be tuned to the operating channel. Tuning may be done at our factory or can be carried out on site.

Clear tuning instructions and also any special tools necessary are supplied along with the combiner.



790719 FM Starpoint combiner, 4x 5 kW

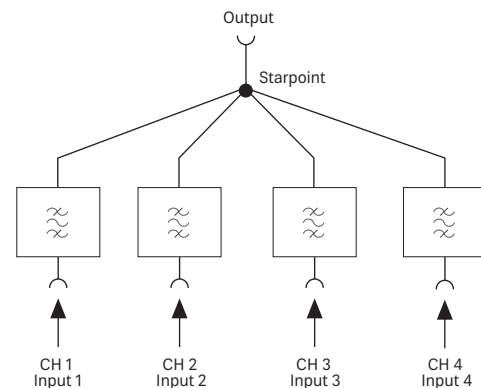

Technical Data

Type No.	Inputs	Insertion loss ⁽¹⁾	Connectors Input / Output	Weight	Dimensions (l x w x h) [mm]	Packing size [mm]
790717	2	< 0.4 dB	1½" EIA / 1½" EIA	220 kg	975 x 695 x 1275	1080 x 890 x 1500
790718	3	< 0.5 dB	1½" EIA / 3½" EIA	335 kg	2185 x 695 x 1260	2x 1080 x 890 x 1500 1x 1080 x 470 x 1500
790719	4	< 0.6 dB	1½" EIA / 3½" EIA	450 kg	2185 x 695 x 1260	2x 1080 x 890 x 1500
Frequency range				87.5 ... 108 MHz		
Channel spacing				> 1.5 MHz		
Isolation				> 35 dB		
VSWR				< 1.1 (at pass band)		
Impedance				50 Ω		
Input power				max. 5 kW (per input)		
Temperature range				-20 °C ... +50 °C		
Material				Aluminium (outer conductor) Brass, silver-plated (inner conductor)		
Colour				RAL 7032 (grey)		

⁽¹⁾ Insertion loss value refers to a 3-dB bandwidth of 800 kHz. Minimum 3-dB bandwidth is 600 kHz.

Directional Filter Combiner

87.5 ... 108 MHz, 200 W

KATHREIN

General

Directional filter combiners enable several transmitters to be connected to one common output. The design offers an expandable system which is constructed in a modular form. The configuration provides the best frequency response and optimum isolation between the inputs.

Design and Construction

This combiner consists of two 3-pole band-pass filters, two 3-dB couplers and a balancing load. One input is narrowband (NB) in accordance with the frequency response of the band-pass filters. The second input is broadband (BB) within the operating frequency range of the 3-dB coupler. The directional filter combiner may be extended by adding further combiners – directional filter combiners as well as starpoint combiners. Any heat produced is dissipated into the surroundings. Thus the combiner is maintenance free and especially safe to operate. The band-pass filters must be tuned to the operating channel. Tuning may be done at our factory or can be carried out on site. Clear tuning instructions and also any special tools necessary are supplied along with the combiner.

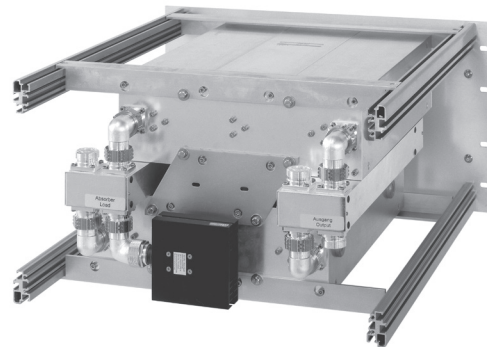

790277 FM Directional filter combiner, 200 W

Technical Data

Type No.	790277	
Inputs	Narrowband input (NB)	Broadband input (BB)
Frequency range	87.5 ... 108 MHz tuned to one channel	87.5 – 108 MHz free choice of channel
Insertion loss ⁽¹⁾	< 0.8 dB	< 0.2 dB
Input power	200 W	800 W
Channel spacing	> 1.5 MHz	
Isolation	> 30 dB (NB to BB-input) > 50 dB (BB to NB-input)	
VSWR	< 1.1 (at pass band) < 1.25 (at stop band)	
Impedance	50 Ω	
Temperature range	-20 °C ... +50 °C	
Connectors	7-16 female	
Colour (front-plate)	RAL 7032 (grey)	
Weight	34 kg	
Dimensions	19" drawer (6 height units, depth 550 mm) ⁽²⁾	

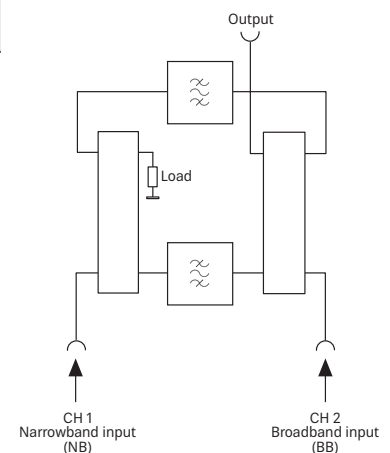

⁽¹⁾ Insertion loss and isolation values refer to the min. channel spacing of 1.5 MHz.

⁽²⁾ One HU (height unit) refers to 44.45 mm.

Directional Filter Combiner

87.5 ... 108 MHz, 5 kW

KATHREIN

General

The directional filter combiners enable several transmitters to be connected to one common output. The design offers an expandable system which is constructed in a modular form. The configuration provides the best frequency response and optimum isolation between the inputs.

Design and Construction

This combiner consists of two temperature stabilised 3-pole band-pass filters, two 3-dB couplers and a balancing load.

One input is narrowband (NB) in accordance with the frequency response of the band-pass filters. The second input is broadband (BB) within the operating frequency range of the 3-dB coupler.

The directional filter combiner may be extended by adding further combiners – directional filter combiners as well as starpoint combiners.

Any heat produced is dissipated into the surroundings via heat sinks. Thus the combiner is maintenance-free and especially safe to operate.

The band-pass filters must be tuned to the operating channel. Tuning may be done at our factory or can be carried out on site.

Clear tuning instructions and also any special tools necessary are supplied along with the combiner.



726473 FM Directional filter combiner, 5 kW

Technical Data

Type No.	726473	
Inputs	Narrowband input (NB)	Broadband input (BB)
Frequency range	87.5 ... 108 MHz tuned to one channel	87.5 – 108 MHz free choice of channel
Insertion loss [†]	< 0.35 ... 0.5 dB	< 0.2 dB
Input power	5 kW	15 kW
Channel spacing	> 0.8 MHz	
Isolation	> 30 dB (NB to BB-input) > 50 dB (BB to NB-input)	
VSWR	< 1.1 (at pass band) < 1.25 (at stop band)	
Impedance	50 Ω	
Temperature range	-20 °C ... +50 °C	
Connectors	7/8" EIA-flange (NB-input) 1 1/8" EIA-flange (BB-input and Output)	
Colour	RAL 7032 (grey)	
Weight	140 kg	
Dimensions (l x w x h)	850 x 560 x 1320 mm	
Packing size (l x w x h)	1015 x 615 x 1400 mm	

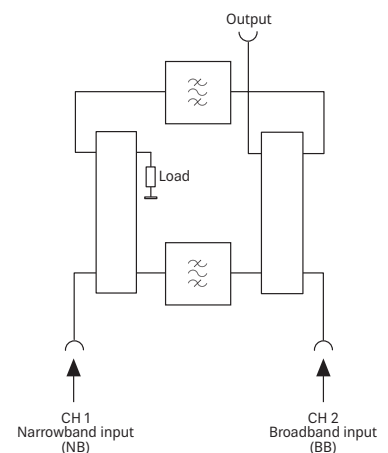

[†] Insertion loss and isolation values refer to the min. channel spacing of 0.8 MHz.

Directional Filter Combiner

87.5 ... 108 MHz, 10 kW

KATHREIN

General

The directional filter combiners enable several transmitters to be connected to one common output. The design offers an expandable system which is constructed in a modular form. The configuration provides the best frequency response and optimum isolation between the inputs.

Design and Construction

This combiner consists of two temperature stabilised 3-pole band-pass filters, two 3-dB couplers and a balancing load.

One input is narrowband (NB) in accordance with the frequency response of the band-pass filters. The second input is broadband (BB) within the operating frequency range of the 3-dB coupler.

The directional filter combiner may be extended by adding further combiners – directional filter combiners as well as starpoint combiners.

Any heat produced is dissipated into the surroundings via heat sinks. Thus the combiner is maintenance free and especially safe to operate.

The band-pass filters must be tuned to the operating channel. Tuning may be done at our factory or can be carried out on site.

Clear tuning instructions and also any special tools necessary are supplied along with the combiner.

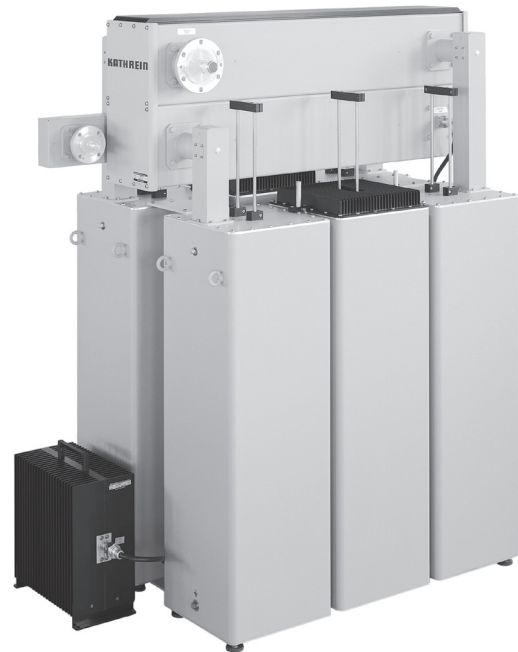

790573 FM Directional filter combiner, 10 kW
(mirror version of 728393)

Technical Data

Type No.	728393	
Inputs	Narrowband input (NB)	Broadband input (BB)
Frequency range	87.5 ... 108 MHz tuned to one channel	87.5 ... 108 MHz free choice of channel
Insertion loss ⁽¹⁾	< 0.3 ... 0.4 dB	< 0.15 dB
Input power	10 kW	50 kW
Channel spacing	> 0.8 MHz	
Isolation	> 35 dB (NB to BB-input) > 55 dB (BB to NB-input)	
VSWR	< 1.1 (at pass band) < 1.25 (at stop band)	
Impedance	50 Ω	
Temperature range	-20 °C ... +50 °C	
Connectors	1½" EIA-flange (NB-input) 3½" EIA-flange (BB-input and Output)	
Colour	RAL 7032 (grey)	
Weight	290 kg	
Dimensions (l x w x h)	1150 x 695 x 1435 mm	
Packing size (l x w x h)	1350 x 870 x 1620 mm	

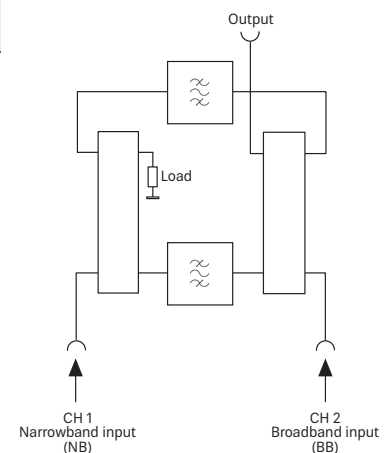

⁽¹⁾ Insertion loss and isolation values refer to the min. channel spacing of 0.8 MHz.



FM Directional Filter Combiner
2 x 5 kW
for Multipattern application



FM Starpoint combiner
with 6 inputs, 5 kW each

Combiners
and Filters

- Several transmitters can be combined to one common antenna.
- Kathrein supplies products of high quality brands.

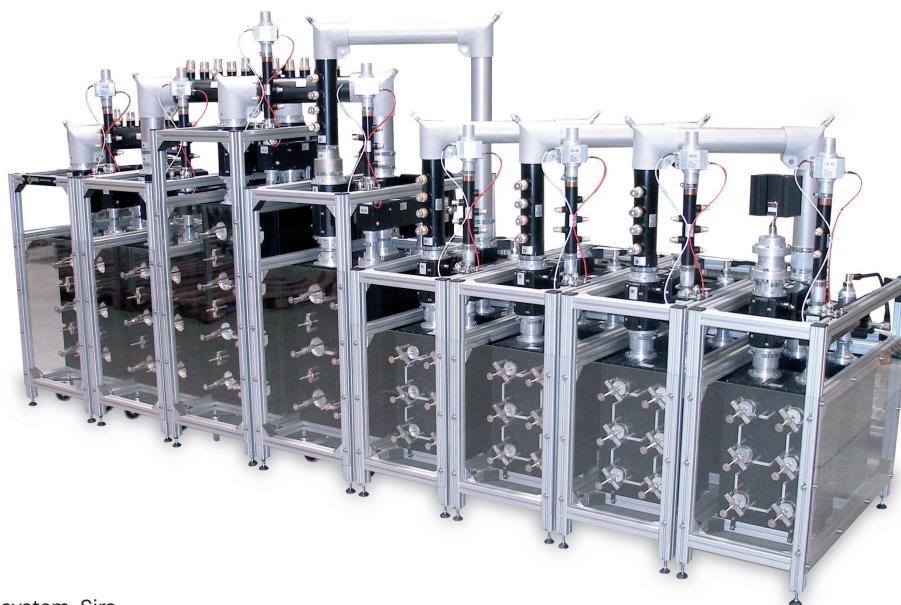

DVB-T combiner system, Sira

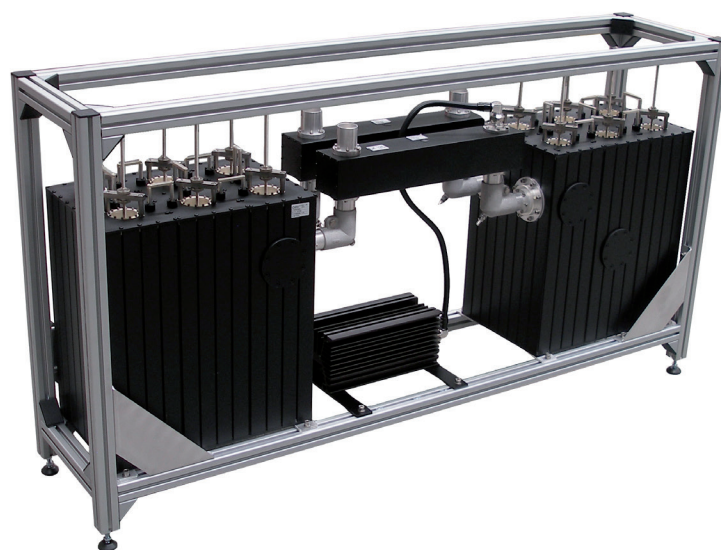

DAB combiner, Sira

Components for Antenna Systems

Patch Panels
Dehydrators
Coaxial Cables and Accessories
Direct Access Units
Mounting Hardware
Electrical Adapters

- KATHREIN supplies products of high quality brands.
- Switching device for:
 - different transmitters
 - antenna halves
 - backup systems
 - dummy loads

Easy connection and disconnection of switching ports by special U-Links

Example: 3-ports, 1 U-Link

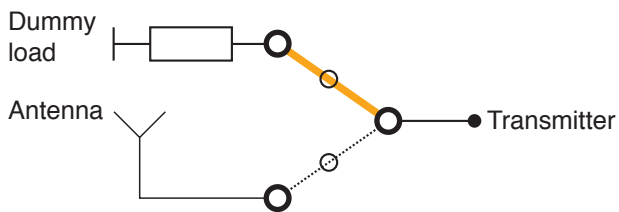

Example: 6-ports, 3 U-Links

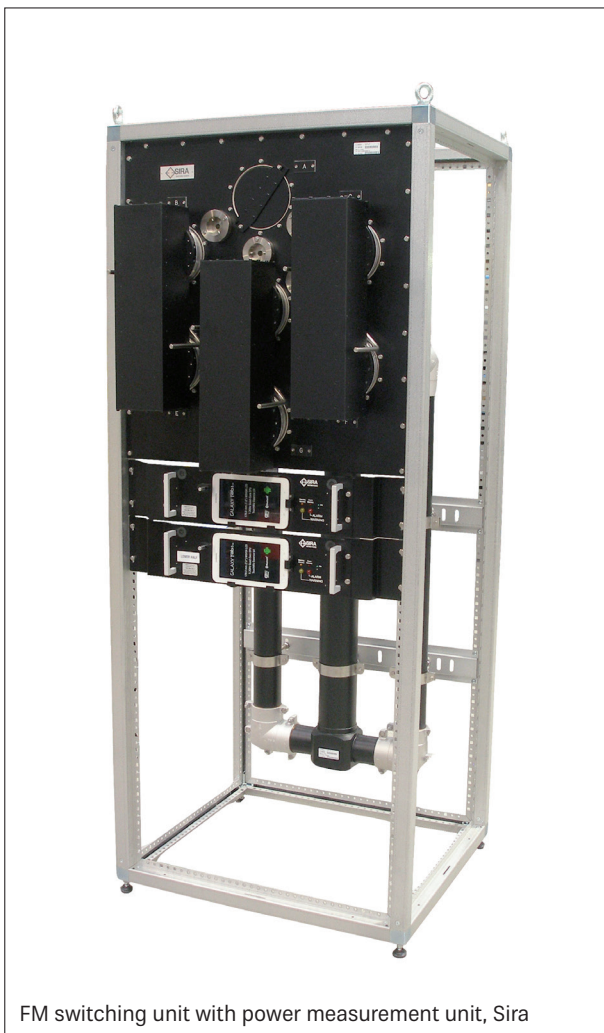
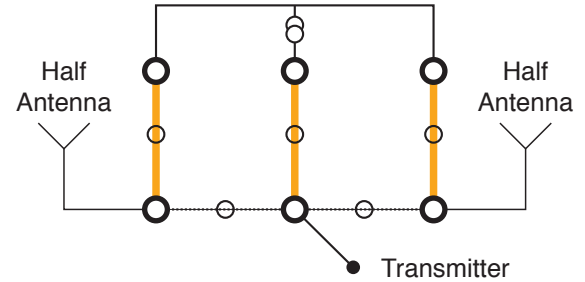

- KATHREIN supplies products of high quality brands.
- Continuous air pressure in RF transmission lines.
- Prevents the occurrence of humidity and condensation.
- Maintenance-free with fully automatic regeneration.
- 19" rack-mounted or wall-mounted.

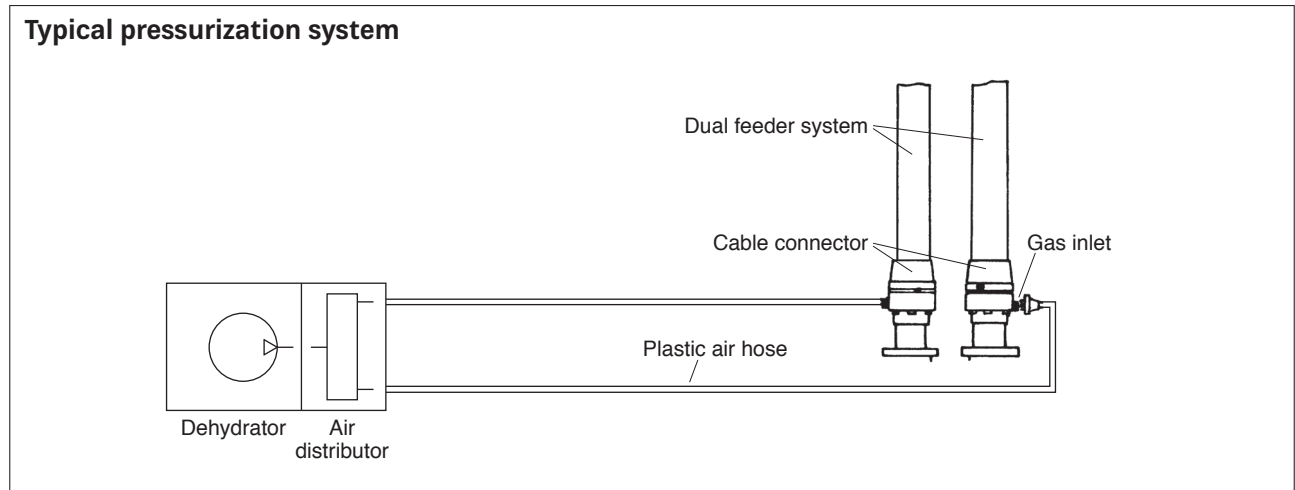

- KATHREIN supplies products of high quality brands.
- Branch cables completely configured, phase-adjusted and fully tested.
- Feeder cables incl. accessories up to 6 1/8".
- Fire retardant jacket available.
- Air or foam dielectric cables.

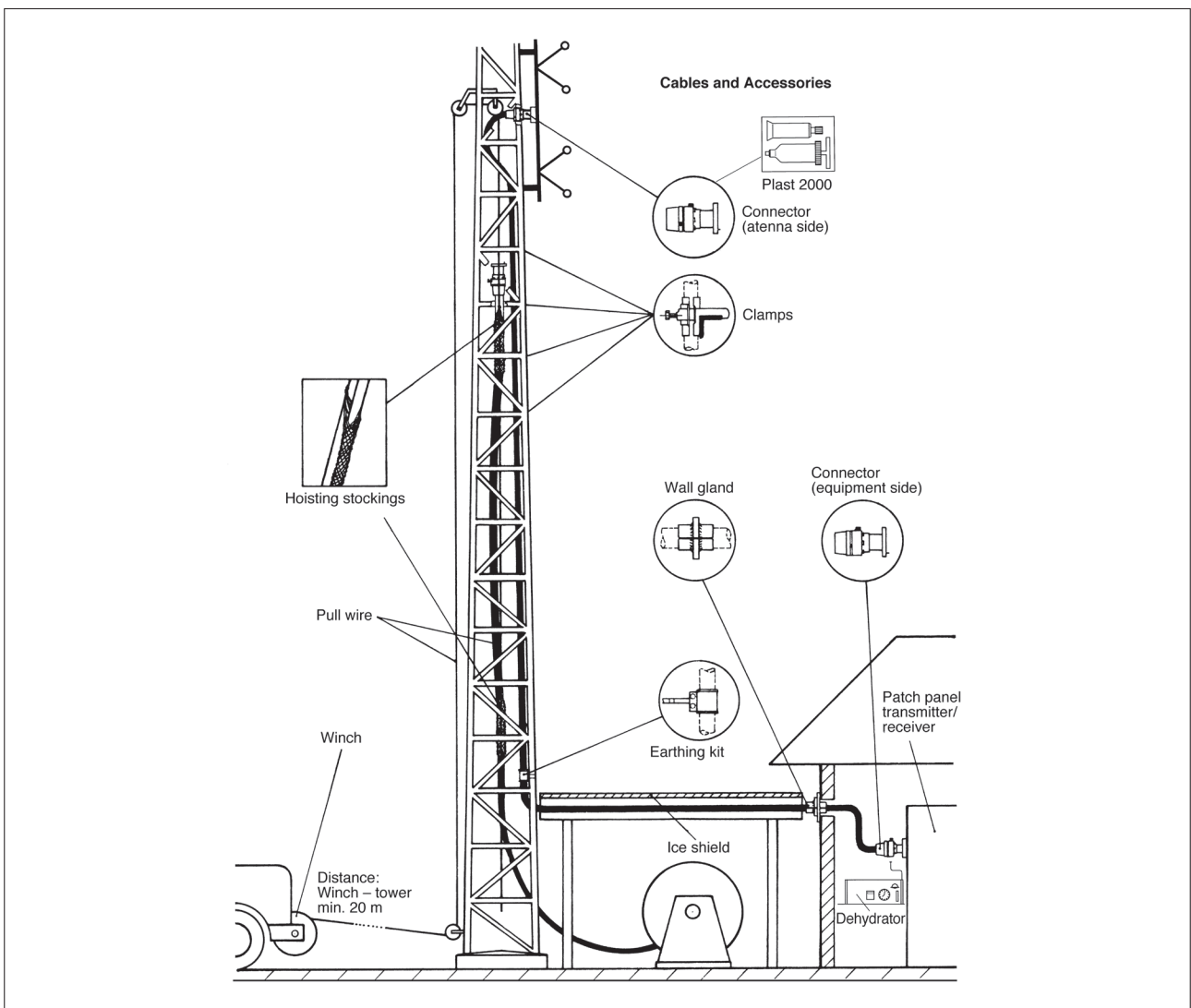

- KATHREIN supplies products of high quality brands.
- Quick and direct access to feeder cables.
- Accurate measurements of VSWR and electrical length.
- Antenna testing and tuning without dismantling the connected feeders.
- For outdoor application.
- Suitable for all broadcast standards.

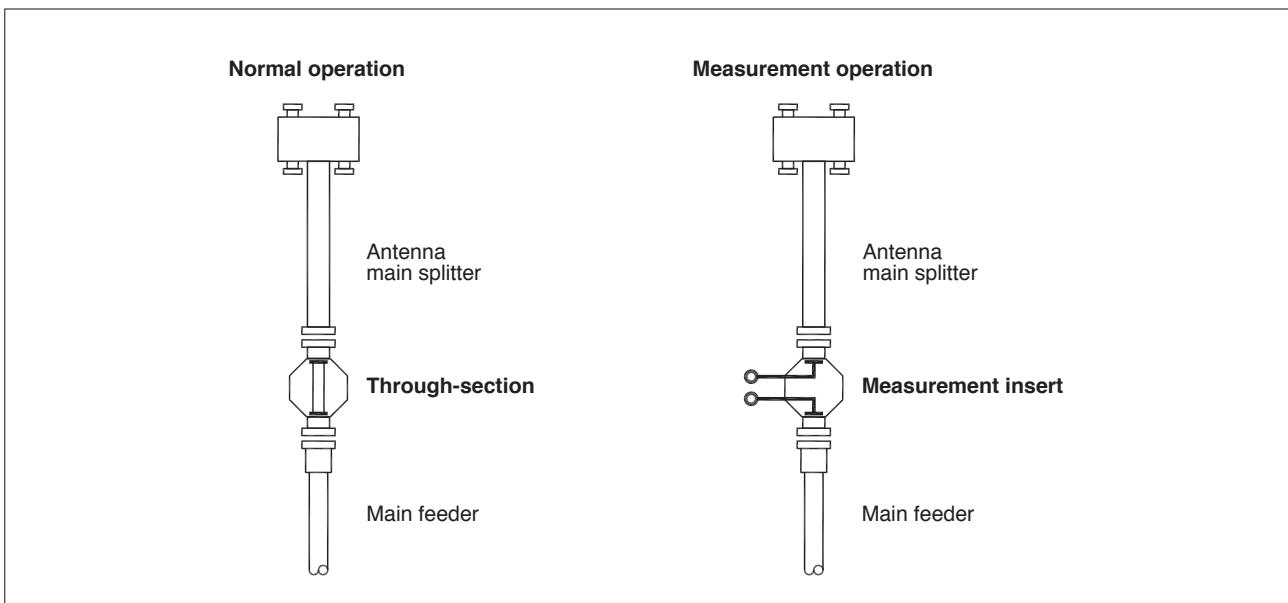

Mounting Hardware for FM Panels

KATHREIN

Components for mounting FM panels to tube masts.

Material: Hot-dip galvanized steel.
Stainless steel bolts and nuts are supplied.

Set of clamps for one horizontal polarized FM panel

Order No.	Suitable for FM panel	Suitable for tube mast of mm \varnothing	Weight kg
753000007	601278	60 – 115	12
	601629		
	715849		
	601694		
753000008	601768	115 – 245	28
	601979		
	75010008		
	752183		

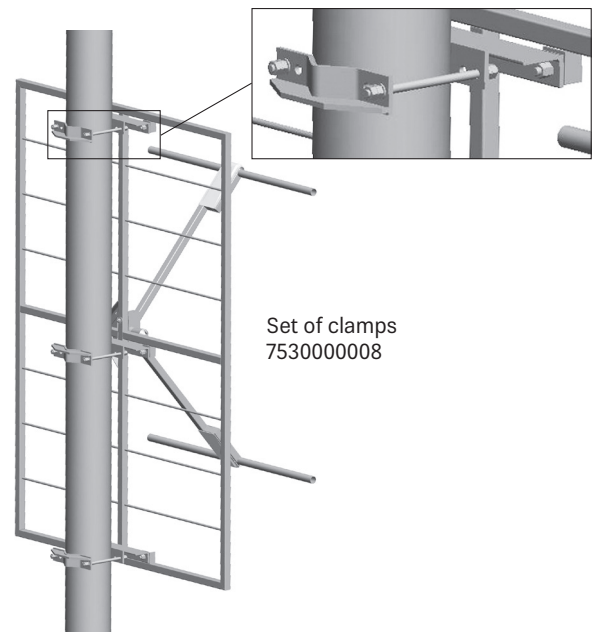

Components for mounting VHF antennas to tube masts.

Material: Hot-dip galvanized steel.
Stainless steel bolts and nuts are supplied.

Pair of clamps for one VHF panel

Order No.	Old type number*	Suitable for tube mast of mm \varnothing	Weight kg
75310466	K61120	60 – 115	3.4
75310465	K61130	115 – 210	4.5

* Number only for reference, do not use for ordering!

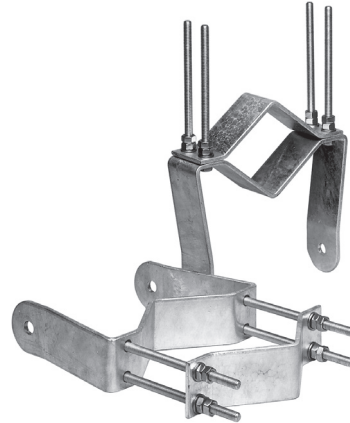

Two pairs of clamps for one VHF dipole

Order No.	Suitable for VHF dipole	Suitable for tube mast of mm \varnothing	Weight kg
75310386	75010295 75010296 75010297	88.9	1.5

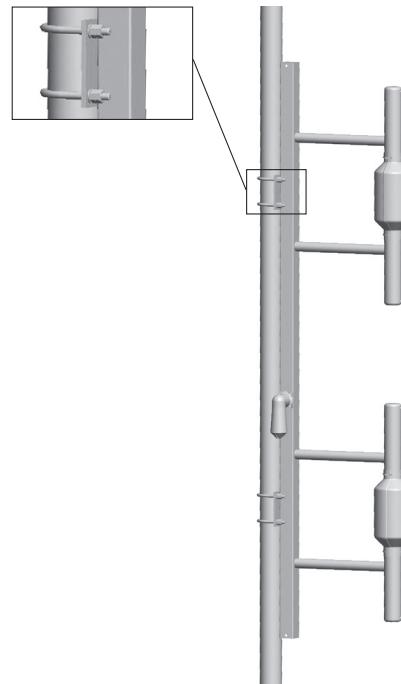

Mounting Hardware for UHF Panels with Attachment Bracket

KATHREIN

Components for mounting UHF panels to tube masts.

Material: Hot-dip galvanized steel.
Stainless steel bolts and nuts are supplied.

Pair of clamps for one UHF panel

Order No.	Old type number*	Suitable for tube mast of mm \varnothing	Weight kg
75310411	K611401	40 – 95	1.6
75310412	K611402	60 – 115	1.6
75310413	K611403	115 – 210	4.0
75310414	K611404	210 – 380	7.2
75310415	K611405	380 – 521	10.2

* Number only for reference, do not use for ordering!



Pair of clamps 75310413

Tilt brackets (pair)
Order No. 600504 (K61301)

For beam tilt down to 10°

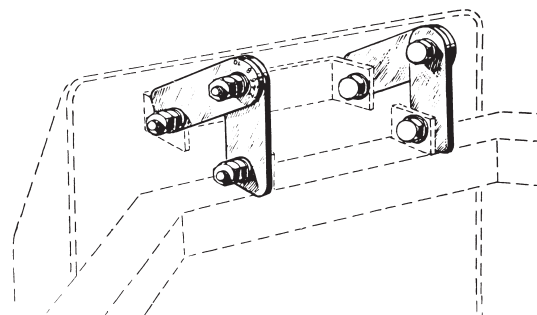

Mounting Hardware for UHF Panels with Attachment Plate

Components for mounting UHF panels to tube masts.

Material: Hot-dip galvanized steel.
Stainless steel bolts and nuts are supplied.

Pair of clamps for one UHF panel with attachment plate

Order No.	Suitable for tube mast of mm \varnothing	Weight kg
75310243	40 – 95	3.5 kg

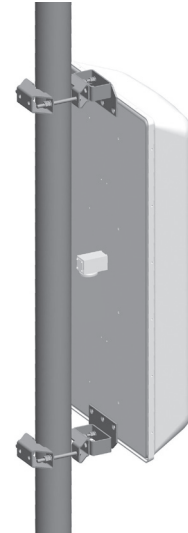

Pair of clamps for two UHF panels with attachment plate

Order No.	Suitable for tube mast of mm \varnothing	Weight kg	Distance A/mm	Angle α between directions of the two UHF panels
75310244	40 – 95	7.0 kg	261	90°

Remark: The radius from the center of the array to the reference point of the panel is given by the distance A.

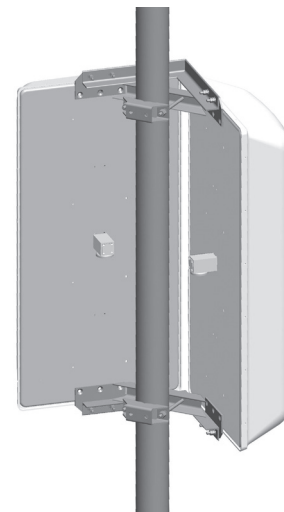

Pair of clamps for three UHF panels with attachment plate

Order No.	Suitable for tube mast of mm \varnothing	Weight kg	Distance A/mm	Angle α between directions of the three UHF panels
75310245	40 – 95	12 kg	261	90°

Remark: The radius from the center of the array to the reference point of the panel is given by the distance A.

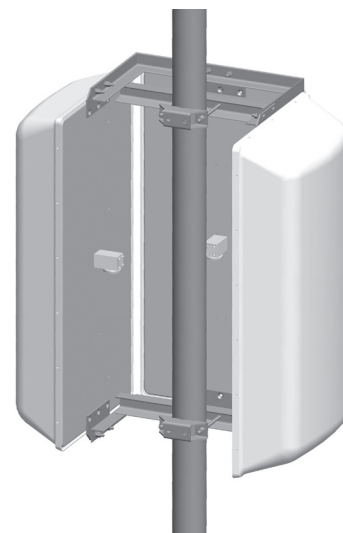

Mounting Hardware for UHF Panels with Attachment Plate

KATHREIN

Mechanical adapters

Pair of mechanical adapters

to convert a panel with attachment plate to attachment bracket version.

Order No. 753000006

Weight: 1.5 kg

Scope of supply: 2 attachment brackets

4 screws

4 washers

8 nuts

lubricant



Mechanical adapter mounted on UHF panel.

Mounting Hardware for UHF Panels with Attachment Bracket

Components for mounting UHF panels to tube masts.

Material: Hot-dip galvanized steel.
Stainless steel bolts and nuts are supplied.

Remark: The radius from the center of the array to the reference point of the panel is given by the distance A.

Pair of clamps for two UHF panels with attachment bracket

Order No.		Suitable for tube mast of mm \varnothing	Weight kg	Distance A/mm	Angle α between directions of the two UHF panels
600843	K611521	70 - 150	6.4	266	90°
600844	K611522	150 - 300	8.8		
600845	K611523	300 - 400	8.8		

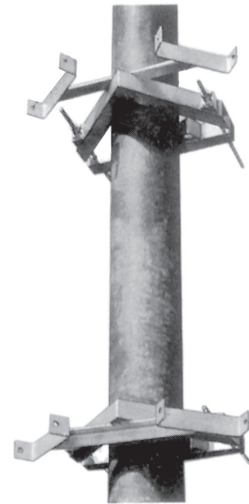

Pair of clamps for three UHF panels with attachment bracket

Order No.		Suitable for tube mast of mm \varnothing	Weight kg	Distance A/mm	Angle α between directions of the three UHF panels
600849	K611541	70 - 150	8.4	266	90°
600850	K611542	150 - 300	9.2		
600851	K611543	300 - 400	9.2		

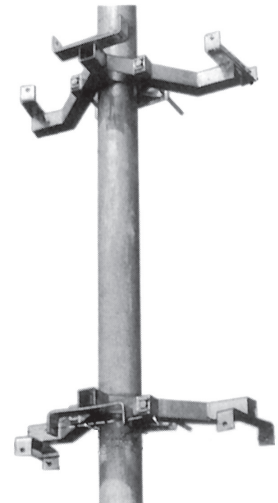

Pair of clamps for four UHF panels with attachment bracket

Order No.		Suitable for tube mast of mm \varnothing	Weight kg	Distance A/mm	Angle α between directions of the four UHF panels
600991	K611561	70 - 150	26	258	90°
600874	K611562	150 - 260	26	258	90°

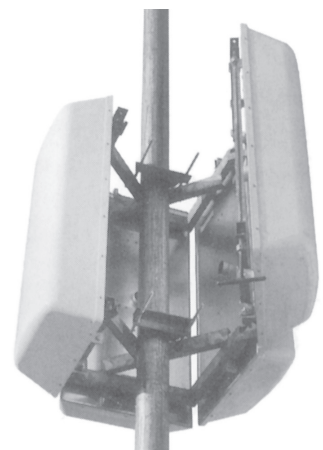

Special features: A part of the mount can be swivelled out for easier mast climbing.

Mounting Hardware for UHF Omnidirectional Antennas

KATHREIN

Order No.	Suitable for Antenna type	Clamp range mm	Weight kg
75310335	75010270	75 - 120	6.0
75310237	75010271	100 - 160	11.0
75310384	75010272	139 - 160	17.0
75310322	75010066 75010067	139 - 160	18.5
75310416	75010068 75010069	wall mount	65.0
75310426	75010068 75010069	top mount	54.0

Notes:

The selection of proper tube mast is under responsibility of the customer. It is necessary to carry out a static and dynamical analysis of the support structure (mast) with the antenna. Please contact us for the relevant mechanical parameters for the analysis, or refer to the antenna datasheet.

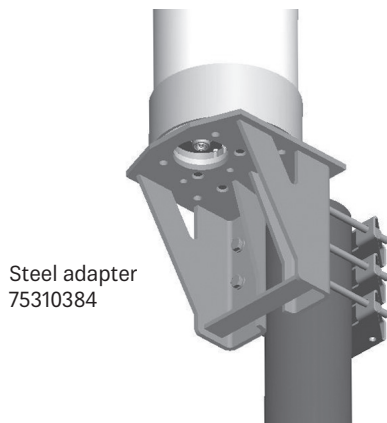

Components for mounting power splitters to tube masts.

Stainless steel bolts and nuts are supplied.

Tension band for mounting medium power splitters

Order No.	Suitable for tube mast of mm \varnothing	Weight kg
759044	30 - 340	0.65

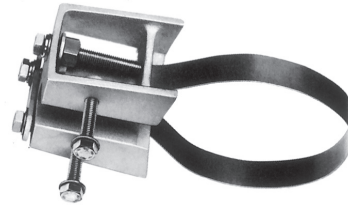

Electrical adapters

Adapters for straight connector to elbow connector

Examples:



7-16 female

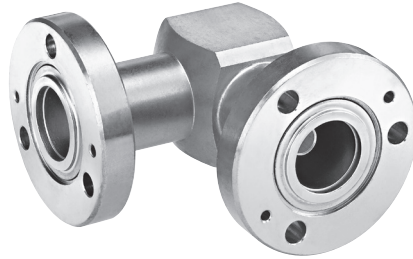

7/8" EIA flange

Order No.	Type	Remark
092930	7-16 m/f	EIA elbows do not include coupling element (bullet) - please order separately.
0922248	7/8" EIA f/f	
0921100	13-30 m/f	
0921262	1 1/8" EIA f/f	

Adapter for 7-16 connector to N-connector



Order No.	Type
092872	7-16 m to N f

The use of elbow adapters

1.

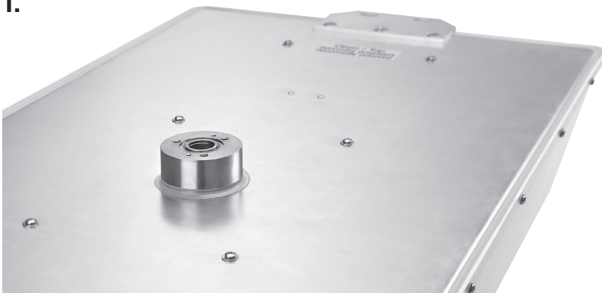

UHF-Panel with straight connector.

2.

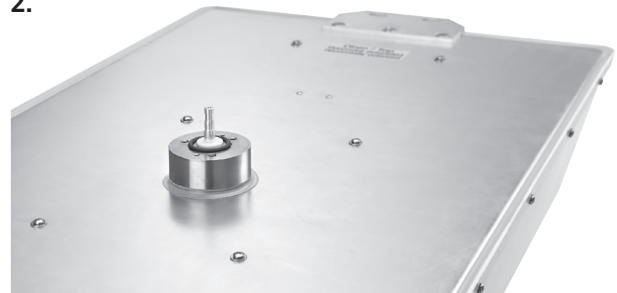

Do not forget to put bullet and O-ring for EIA connctions.

3.



UHF-Panel with straight connector and elbow adapter.

Monitoring of indoor and outdoor components of antenna systems

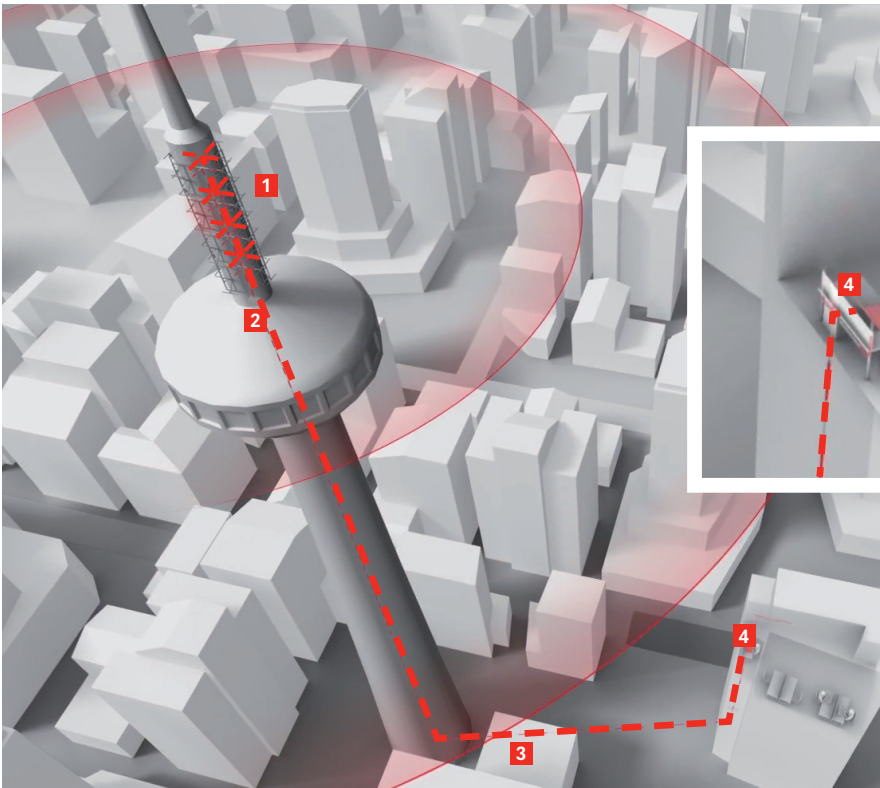

- 1 Sensors
- 2 Junction box (JB)
- 3 Data logger (DL)
- 4 Analytics software

Why antenna monitoring?

- Ensure antennas and components deliver best performance at all times
- Detect malfunctions directly in the tower
- Schedule proactive maintenance
- Optimise costs for regular maintenance

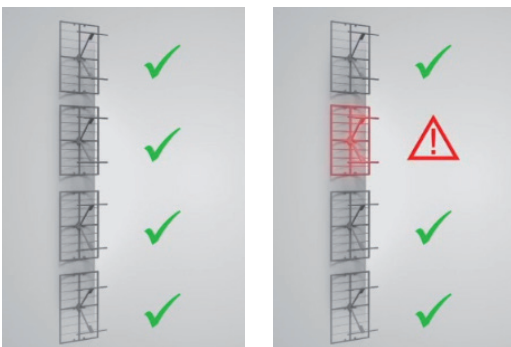

Real-time precision online monitoring

- Real-time detection of performance degradation
- Immediate failure detection and exact localisation
- Web-based application
- Push messages
- Configuration of alarm thresholds
- Interface to overall provider management system (SNMP)

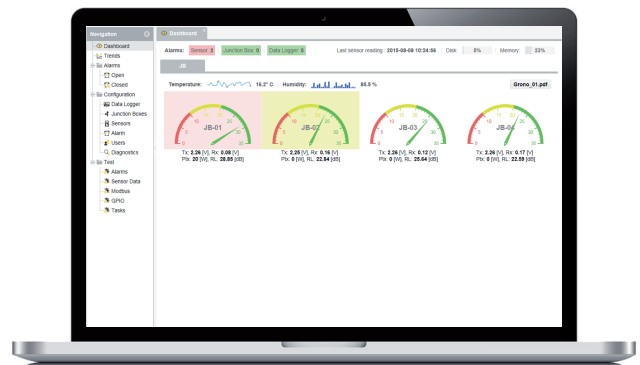

Powerful cockpit

- Power and return loss trend curves for preventive maintenance
- Analysis of antenna performance in relation to weather conditions
- Proof of service levels

For more information
please see
our detailed brochure

New product

Broadcast Signal Analysis System based on SDR and digital broadband receiver

Kathrein is presenting a high-performance solution to analyse your broadcasting networks. The measurement and investigation tool for analogue and digital broadcasting (Kathrein Signal Analyser) is a powerful and complete system to assist you through any phase of radio network planning, realisation and maintenance as well as in the quality assurance of your broadcasting networks.

Advanced digital signal processing algorithms

Kathrein Signal Analyser strictly follows the concept of SDR (Software Defined Radio). The input with high quality I/Q-data comes from a suitable test receiver. Demodulation, channel decoding and measurement of all relevant parameters, as well as generation of statistics and graphics, are performed by the Kathrein Signal Analyser software. Advanced digital signal processing algorithms allow robust and precise measurements, both in stationary and mobile environments.

Functionality

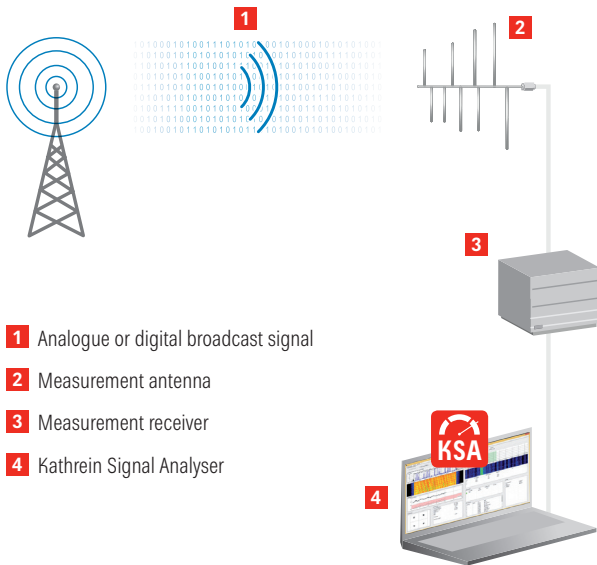

- 1 Analogue or digital broadcast signal
- 2 Measurement antenna
- 3 Measurement receiver
- 4 Kathrein Signal Analyser

Hardware

Kathrein Signal Analyser is hardware independent. We recommend professional equipment like R&S TSMW, NI PXI or IZT R3000.

Measure

All listed broadcast technologies can be measured in parallel with one hardware. The measurement system is suitable for mobile, as well as stationary and long-term measurements. The powerful channel-scans give a fast overview over the band. Radiation pattern and height profile can be recorded. Many other analysis features are included.

- FM
- DRM/DRM+
- DAB / DAB+
- DMB
- DVB-T
- DVB-T2
- LTE
- FeMBMS **NEW**

Export function

Create TAB separated files to visualise the measurement with all parameters individually. Import them into any geographic information system (GIS) such as MapInfo, ArcView or even GoogleEarth.

Optional: Replay software

After performing the measurements, measured data can be replayed and analysed in detail with the Replay software option. Measurement data are displayed on a topographic map and in trace charts. Spectrum, constellation, channel impulse response and many more parameters can be investigated in detail.

Optimised for mobile use

The concept of software-defined radio provides maximum flexibility and allows measurement of multiple technologies with one hardware setup. Together with flexible post-processing software and a user-friendly interface, radio frequency (RF) and quality of service (QoS) measurements can be carried out quickly and seamlessly for every technology.

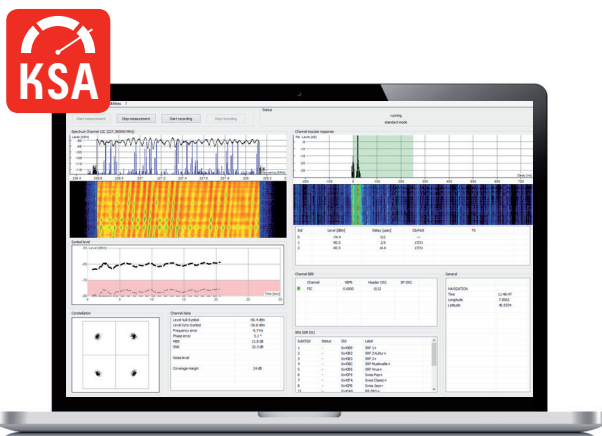

- Waterfall diagram
- Spectrum
- Constellation
- Channel impulse response
- and many more

Please contact us for more detailed information. Customized signal analyser configurations can be offered on request.

A full range of services for broadcast antennas and systems



> Planning

- Coverage calculations
- Network planning
- Site survey
- Technical proposals
- Structural calculations (static/dynamic)
- Site acquisition
- System planning

> Material Logistics

- Storing of consumable items
- Spare part management
- Accessories

> Implementation

- Project management
- System integration
- Turnkey projects
- Installation
- Commissioning
- Security management

> Operation

- Regular checks of RF-component and mechanical structure
- Troubleshooting and fault elimination
- Emergency service 24/7/365
- Regular supervision and maintenance
- Antenna realtime monitoring
- Repair service
- RF-measurements, data logging, reports

> Maintenance

- Technical support
- Hardware maintenance
- On-site support

> Training

- Antenna basics and technology training
- Service and measurement training
- Product handling and installation training (optionally on-site)

Please contact us for a customized service package exactly tailored to your requirements.

Technical Annex

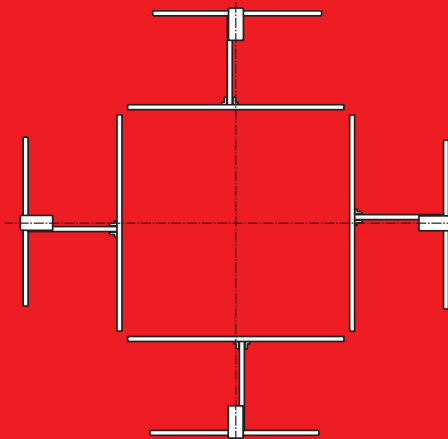
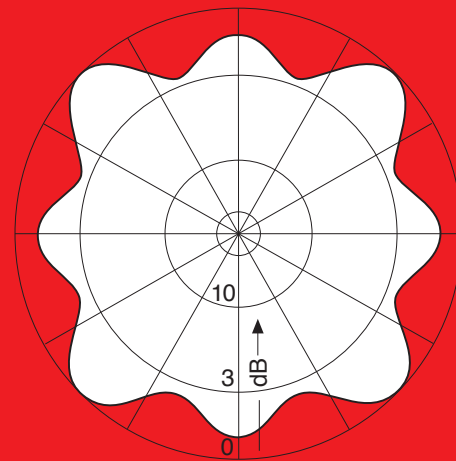
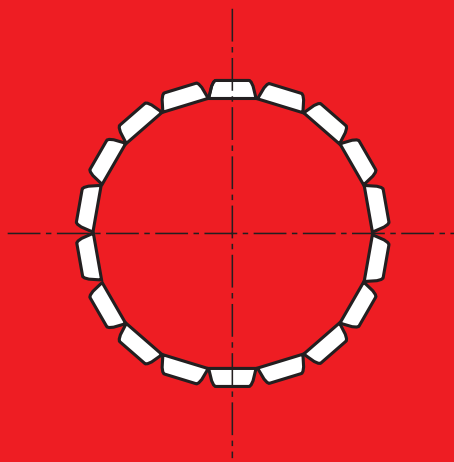

Kathrein offers a wide variety of antenna systems, allowing the broadcaster to select the optimum configuration for each station.

Following is an overview of various arrays and their typical characteristics and advantages.

Three-sided Panel Array

The individual panels are designed to cover an azimuth sector of 120 degrees and three panels fed with equal power will result in an omni-directional pattern. Directional horizontal radiation patterns can be achieved by using a different panel arrangement and/or feeding the panels with unequal power levels.

This arrangement is especially suitable for triangular and round towers or masts. These broadband systems are available with horizontal or circular polarization.

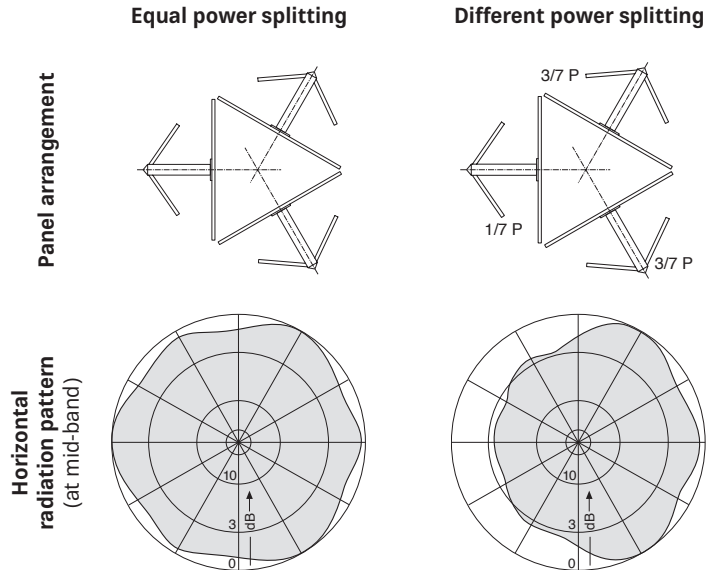

Four-sided Panel Array

The individual panels are designed to cover an azimuth sector of 90 degrees so that four panels fed with equal power will produce an omni-directional pattern. Again, directional horizontal radiation pattern can be produced with other panel arrangements and unequal power fed to various panels in the array.

This configuration is especially suitable for square towers or masts. These broadband systems can be supplied for any polarization.

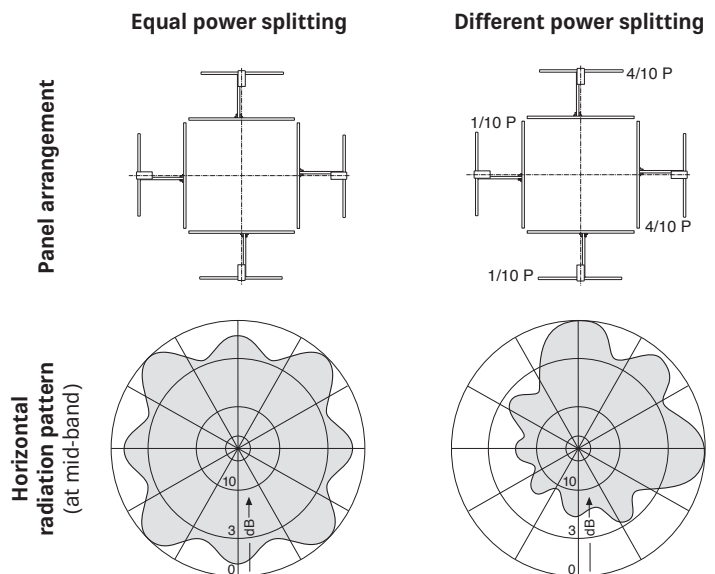

Turnstile and Superturnstile-Antennas

This type of antenna (also known as a "batwing") produces an excellent horizontally polarized omni-directional pattern.

A metal mast can be placed in the center of a turnstile-antenna as long as the mast has a small diameter relative to the wavelength of the signal.

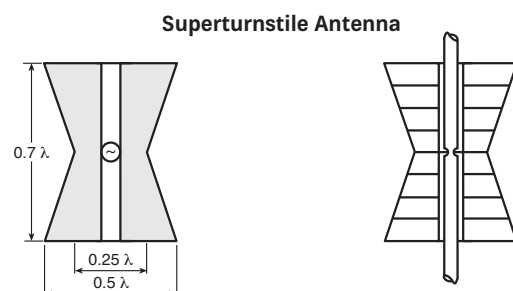
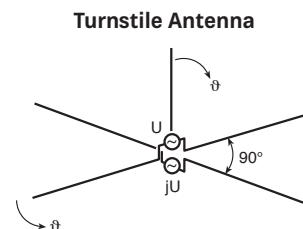

Multi-panel Array

If the cross section of the mast or tower is more than one wavelength it is impossible to obtain a satisfactory omni-directional horizontal radiation pattern using three or four panels per bay. However, an omni pattern can be achieved by increasing the number of panels per bay. The horizontal patterns of these "multi-panel" arrays will vary with frequency, but they can be designed for excellent omni performance over limited bandwidths. Multi-panel arrays are available with horizontal or vertical polarization.

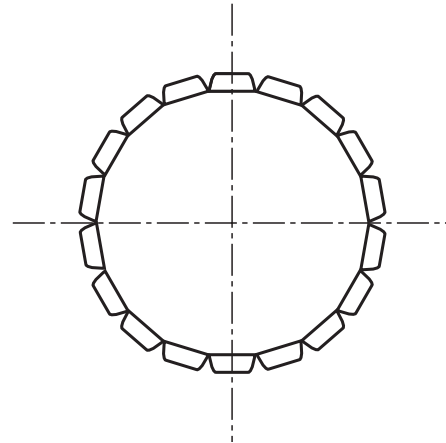

Special Antenna Systems Inside Self-supporting GRP Towers

A large-diameter GRP (Glass Reinforced Plastic) pipe can be utilized to substitute a metal support structure and enclose an antenna system. The GRP pipe is transparent to RF energy and it allows the antenna engineer to use an optimized antenna design with a small cross-section at the center of the pipe. Antenna elements may be dipoles or turnstiles. The GRP pipe also provides excellent protection against severe environmental conditions such as rain, ice, snow, wind and corrosive agents and it allows access for inspections and maintenance at any time. Horizontally and vertically polarized systems can be supplied.

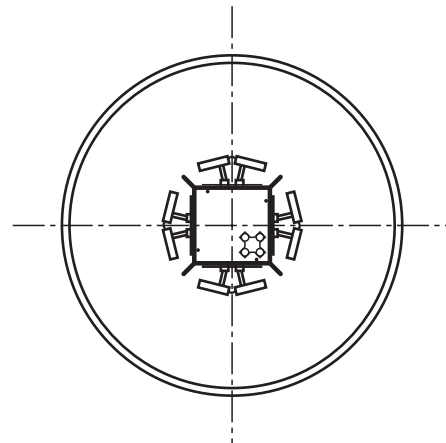

Examples for Radiation Patterns

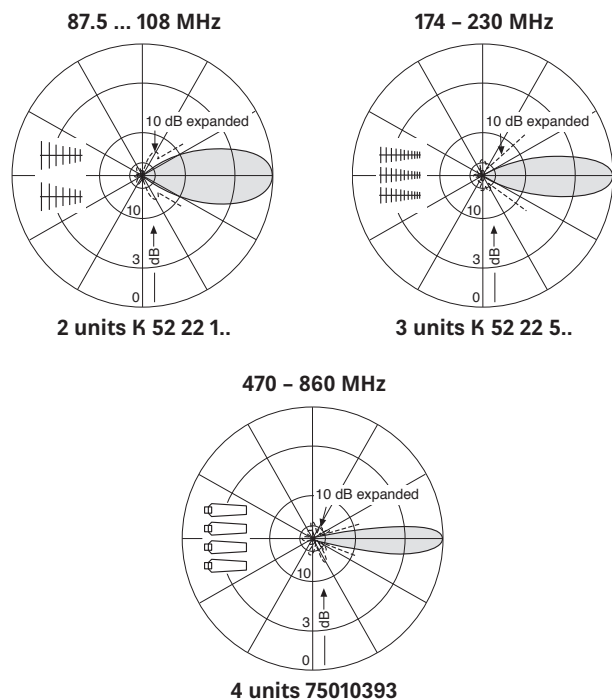

Relay Receiving Antennas

For professional receive applications such as transposer/translator inputs Kathrein offer a full range of antennas including yagis and logarithmic-periodic types. UHF models are equipped with radomes to assure reliable operation in icing conditions and to protect the antennas against weather damage.

Arrays of these antennas are available to provide very high gain, extremely narrow main lobes, and high rejection of co-channel and other interfering signals coming into the rear and sides of the array. Receiving antennas and arrays are available with either horizontal or vertical polarization.

Antenna Gain

The gain of an array describes the increase of signal in the main radiation direction which is produced by reducing radiation in all other directions and concentrating it in the main beam. The gain of a broadcast antenna system is normally increased by using a larger number of vertical bays (increasing the vertical aperture) and thereby forming a more narrow vertical radiation pattern.

In the case of a directional antenna system the gain is increased by reducing or eliminating radiation toward azimuth segments and re-directing it toward the areas where coverage is desired.

When calculating the gain of an array the losses in the feeder cables and the power splitters must be taken into account.

Downtilt in Panel Arrays

When transmitting antennas are located on elevated sites it is often beneficial to tilt the main beam of the vertical radiation pattern downward to provide higher signal levels in the areas to be served. There are two ways to accomplish downtilt (also known as "beam tilt"). The panels can be mechanically tilted to direct the beam downward, or phase differences can be introduced into the array feeder system to achieve electrical tilt.

Impedance Tuning

While the VSWR of a well-designed antenna system can be optimized by the use of tuning devices it is not possible to achieve broad bandwidth by compensating for poor components with tuners.

The characteristics of a truly high quality antenna system are established in many ways, beginning with proper component design and manufacture followed by competent system design and installation.

Mast or Tower Dimensions for Panel Arrays

The radiation pattern of a panel array depends on the relative positions of the individual panels in space and the relative amplitude and phase of the RF energy fed to each panel. Therefore it is necessary to have exact dimensional information about the supporting tower or mast if one is to optimize an array design.

The cross section of the mast or tower should be less than one wavelength for a good omni pattern. As the cross section increases beyond one wavelength nulls in the horizontal radiation pattern will rapidly become deeper.

Measurement Links

When large-diameter coax lines are used in an antenna system it is not possible to easily connect measurement equipment without disassembly of the coax system. In these cases it is advisable to install measurement links in the coax feeders to allow convenient connection of test equipment to the antenna system.

Mismatch Compensation

In a broadcast panel array the impedance match of individual panels can be disturbed by mutual coupling, icing and the presence of nearby obstacles. For this reason it is necessary to design the feed system so as to cancel reflections within the array and thereby minimize the presence of reflected signal at the antenna system input. This technique is also known as impedance compensation.

Null Fill

Panel arrays with multiple vertical bays will exhibit deep nulls in the vertical radiation pattern if all bays are fed with equal phase and amplitude. It is important to fill these nulls for proper signal coverage.

For analog TV systems it is not sufficient to provide the minimum signal level, but it is necessary to make the direct signal bigger than any reflexion to avoid ghost pictures.

There are three methods of introducing null fill in a panel array:

- Mechanically tilting some panels downward
- Using a non-linear phase taper between bays
- Using an unequal power split between bays

Since some energy is taken from the main beam to fill the null, the maximum gain of the antenna system will be reduced, typically 0.5 to 1.5 dB, when null fill is introduced.

Polarization

The polarization is defined as the direction of the electrical vector, in practice the plane of the dipoles.

The electric field of an antenna system can be split into a horizontal and a vertical component. If there is only one component, the polarization is pure horizontal or vertical (plane polarized). If there are two components which are not in phase, the polarization is elliptical.

For slant polarization both must exist and they must be in phase.

When an antenna produces vertically and horizontally polarized fields with equal amplitude and with a phase difference of exactly 90 degrees, the resulting signal is circularly polarized.

Power Rating of Components

Generally, the power rating of components refers to the maximum CW power (or mean power) level that can be applied to the input.

The maximum mean power output of an analog TV transmitter occurs during transmission of a black picture and it is typically equal to 70% of the nominal peak sync power level.

For DTV and DAB the nominal transmitter power will occur as the effective mean power level, however, special attention has also to be paid to the voltage load of the system (voltage “crest-factor” due to OFDM modulation).

Split Antenna Systems

An antenna system can usually be divided into upper and lower halves which can be operated separately.

This arrangement allows the use of one half for broadcast operations while the other half is available for painting or maintenance or other work that must be performed in close proximity to the antenna.

The signal level will be reduced by 6 dB if one half of the antenna is fed with one half of the normal transmitter power. If the full transmitter power is available, the use of one half of the antenna will reduce the signal level by only 3 dB.

It will be necessary to climb the mast or tower to perform antenna switching unless a coax patch panel is installed at the transmitter output with two main feeders up to the antenna inputs.

Introduction

Filters and combiners are essential components of many broadcasting antenna systems. They are used for selecting frequencies, suppressing disturbing emissions and noise sidebands. Several channels can be combined into one common antenna by using combiners. In certain cases, separate antenna diagrams for individual channels can also be generated.

Selection of parameters

According to their use as elements of a system, filters are constructed as two-port networks and are matched to the impedance of the other system elements (e.g. transmitter, receiver, antenna or connecting cables) at both the input and the output.

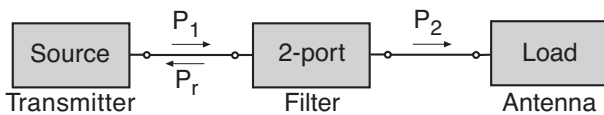

$$P_2 = P_1 - P_r - P_v$$

P_1 = Input power

P_r = Reflected power

P_v = Power loss through filter

P_2 = Power transmitted

Fig. 1: Filter as element of a system.

Frequency response

The attenuation usually depends on the frequency used. This relationship is illustrated in diagram 1, showing a typical attenuation curve for a filter. A plot of the attenuation vs frequency shows the typical filter curve. The attenuation a (1.1) is the logarithmic ratio between input power and transmitted power.

Matching

As a measurement of how a filter is matched the return loss, which is the logarithmic relationship between the input and reflected power a_r (1.2), is displayed in diagram 2.

The return loss a_r , reflection coefficient r and VSWR factor s (1.3 and 1.4) are all related according to the formulas.

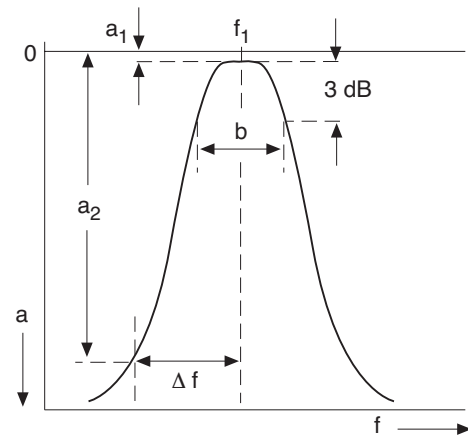

Diagram 1: Frequency response of a filter tuned to frequency f_1 with insertion loss a_1 , stop band attenuation a_2 at the frequency of $f_1 - \Delta f$ and with bandwidth b at 3 dB.

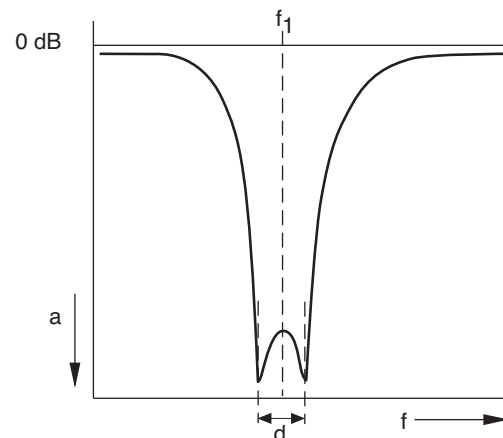

Diagram 2: Return loss of a 2-cavity band-pass filter, tuned to the frequency f_1 and with pass-band bandwidth d .

$$a / \text{dB} = 10 \log \frac{P_1}{P_2} \quad (1.1)$$

$$a_r / \text{dB} = 10 \log \frac{P_1}{P_r} \quad (1.2)$$

$$a_r = -20 \log |r| \quad s = \frac{1 + |r|}{1 - |r|} \quad (1.3)$$

$$(1.4)$$

Filters

Where used in broadcasting systems, filters are normally set up as a combination of several $\lambda/4$ resonators. The Q factor of the resonators is very important with regard to the electrical data and is influenced by the shape and volume of the filter as well as by the conductivity of the material used.

The selectivity of the filters used for combiners has a decisive influence on the minimum spacing required between the transmitters to be connected onto one common antenna. If the frequency spacing is narrow then the filters must similarly be tuned in a very narrow way. But this will cause an increase in the insertion loss resulting in the filters becoming hot (diagram 3). This problem can be avoided if filters of greater volume are used which have a relatively lower insertion loss.

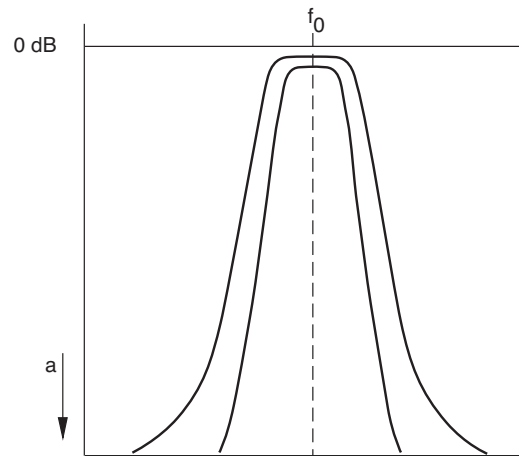

Diagram 3: Examples of two different tuning possibilities for a band-pass filter. Narrower tuning will result in higher insertion loss and steeper slopes.

Directional couplers

A directional coupler is a reciprocal four-port construction, whereby two of the ports are isolated from each other.

For example, the power fed in at port 1 is split up to ports 2 and 3, whereas port 4 is isolated. The power fed into the other ports is similarly split.

If the coupling range of a transmission-line coupler is $\lambda/4$ at the center frequency f_m then the coupling attenuation over a frequency range of $f_1/f_2 = 2$ is almost independent of the frequency (fig. 3).

For example, with a 3-dB directional coupler there is a divergence of ± 0.4 dB and phase difference of 90° occurs between the signals at ports 2 and 3, which is also almost independent of the frequency (fig. 2).

If every port is terminated with a reflection-free load, then the formulas for coupling attenuation and directivity apply.

Coupling attenuation

$$a_k = 10 \log \frac{P_1}{P_2}$$

Directivity

$$a_d = 10 \log \frac{P_2}{P_4}$$

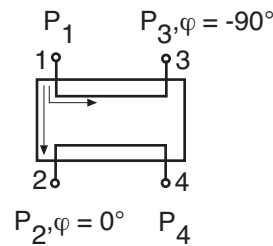

Fig. 2: Directional coupler.

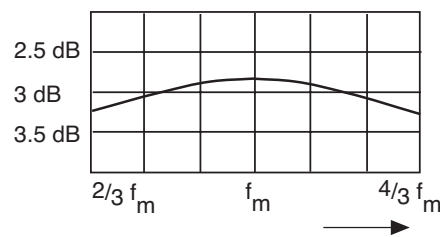

Fig. 3: Coupling attenuation for 3-dB transmission-line coupler of $\lambda/4$ length.

Combiners

Combiners are a combination of frequency-selecting components (e.g. filters, stretchlines) with nodes and connecting elements (e.g. directional couplers, starpoints).

In high quality combiners bandpass filters are used in preference to stop band filters.

Starpoint combiners

Starpoint combiners for n channels consist of n band-pass filters with outputs that are connected to a common starpoint.

The individual band-pass filters are tuned to the respective frequencies. Since the band-pass filters are mismatched outside their pass-bands (with inductive coupling the impedance approaches a short-circuit) the impedance can be transformed up to very high levels by selecting the appropriate length for the link between the filters and the starpoint.

This means that for every input the transformed impedances of all the other inputs are very high at the starpoint which produces a very low parallel load at the antenna output.

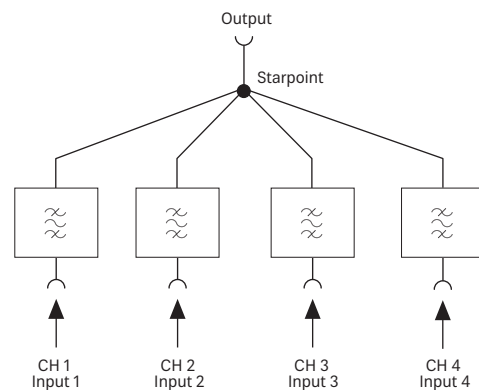

Fig. 4: Starpoint combiner for 4 channels

Directional filter combiner

Directional filter combiners are a combination of filters and 3-dB couplers. One module consists of two band-pass filters, two 3-dB couplers and a balancing load.

One input is narrowband, corresponding to the band-pass curve of the band-pass filter. The other input is broadband, corresponding to the operating range of the 3-dB coupler.

Compared to other types of combiners that can be produced at less expense, directional filters offer a number of useful advantages:

- Simple set-up of multiple combiners through cascading of modules
- Very high isolation between the inputs
- Broadband matching at all inputs
- Easy extension of existing combiners by adding new modules.

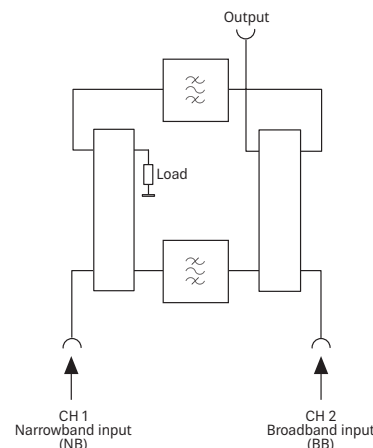

Fig. 5: Directional filter combiner

Function of module

The signal fed into the narrowband input is split into two halves by the 3-dB coupler. Both of these pass through one of the band-pass filters to the second 3-dB coupler where they are then added in equal phase at its output due to the 3-dB couplers function. At the broadband input the two partial signals are anti-phase and therefore practically no signal appears at this port. The broadband input is isolated from the narrowband input by the directional coupler. However the isolation depends on the band-pass filters being identically tuned.

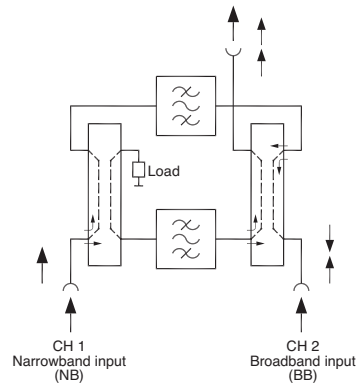

Fig. 6: Functioning of module

The frequency of a signal fed into the broadband input lies within the stop band of the band-pass filters. The signal is split into two halves by the 3-dB coupler and reflected completely by the band-pass filters and proceeds to the output after co-phase addition. The narrowband input is isolated from the broadband input by the directional coupler, as described above, but there is additional isolation due to the stop band attenuation of the band-pass filters.

Cascading of modules

Multiple combiners are easily set up by using several modules with the output of each module feeding the broadband input of the next module. The number of channels possible in a given frequency band is limited only by the minimum spacing between the signals. However limitation can also arise because the insertion loss for each additional module increases by 0.05 up to 0.2 dB and can assume intolerable values.

The power rating of the 3-dB coupler at the output also can limit the number of channels in practice.

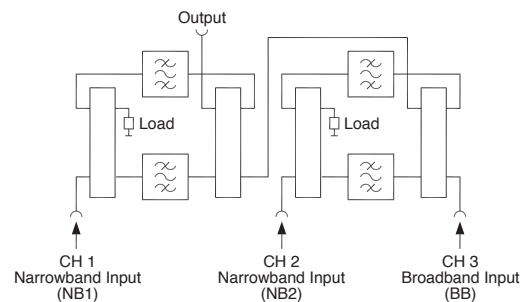

Fig. 7: Directional filter combiner with 2 modules

Multiplexer

Multiplexers consist of one or more directional filter modules and a starpoint combiner. The output of the starpoint combiner is connected to the broadband input of the directional filter combiner. It is advantageous to feed the channels with the largest possible frequency spacing into the starpoint combiner since this produces the optimal isolation. The isolation between the narrowband input to the starpoint combiners' inputs is determined by the directional couplers and additionally by the stop-band attenuation of the band-pass filters.

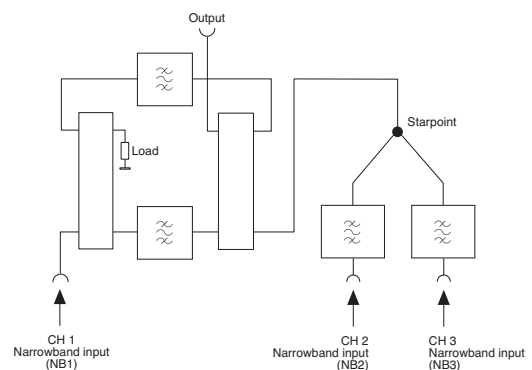

Fig. 8: Multiplexer for three channels

Comparison

Starpoint combiners / Directional filter combiners /
Multiplexers

Combiner Type	Starpoint combiner	Directional filter combiner	Multiplexer
Set-up	Band-pass filters + starpoint	Band-pass filters + 3-dB coupler	Directional filter + starpoint combiner
Spacing FM: 30 W – 1 kW FM: 3 kW – 20 kW	2.5 MHz 1.5 MHz – 2 MHz	2 MHz 0.8 MHz – 1 MHz	2 MHz 1 MHz
Matching (VSWR)	All inputs matched in pass-band range	All inputs broadband matched	Starpoint inputs: pass-band matched Directional filter inputs: broadband matched;
Frequency response	All inputs are narrow-band according to frequency response of the band-pass filters	Narrowband input: according to frequency response of the band-pass filters Broadband input: not selective	All inputs are narrowband according to frequency response of the band-pass filters
Isolation	According to stop-band attenuation of the band-pass filters	NB – BB: attenuation through 3-dB coupler BB – NB / NB – NB: Attenuation through 3-dB coupler + stop-band attenuation of band-pass filters	Between starpoint inputs: like starpoint combiner Directional filter inputs: attenuation through 3-dB coupler + stop band attenuation of band-pass filters
Extensions	With additional band-pass filter; new starpoint cabling necessary	Very simply by adding up a directional filter module; no altering of existing cabling	Simple by adding new directional filter module between starpoint and directional filter; altering of existing cabling necessary
Costs	Economical solution for wide frequency spacing	Sophisticated solution with several technical advantages	Costs between starpoint and directional filter combiner; smaller frequency spacing possible than with starpoint

VSWR, Return Loss Reflected Power, Reflection Coefficient

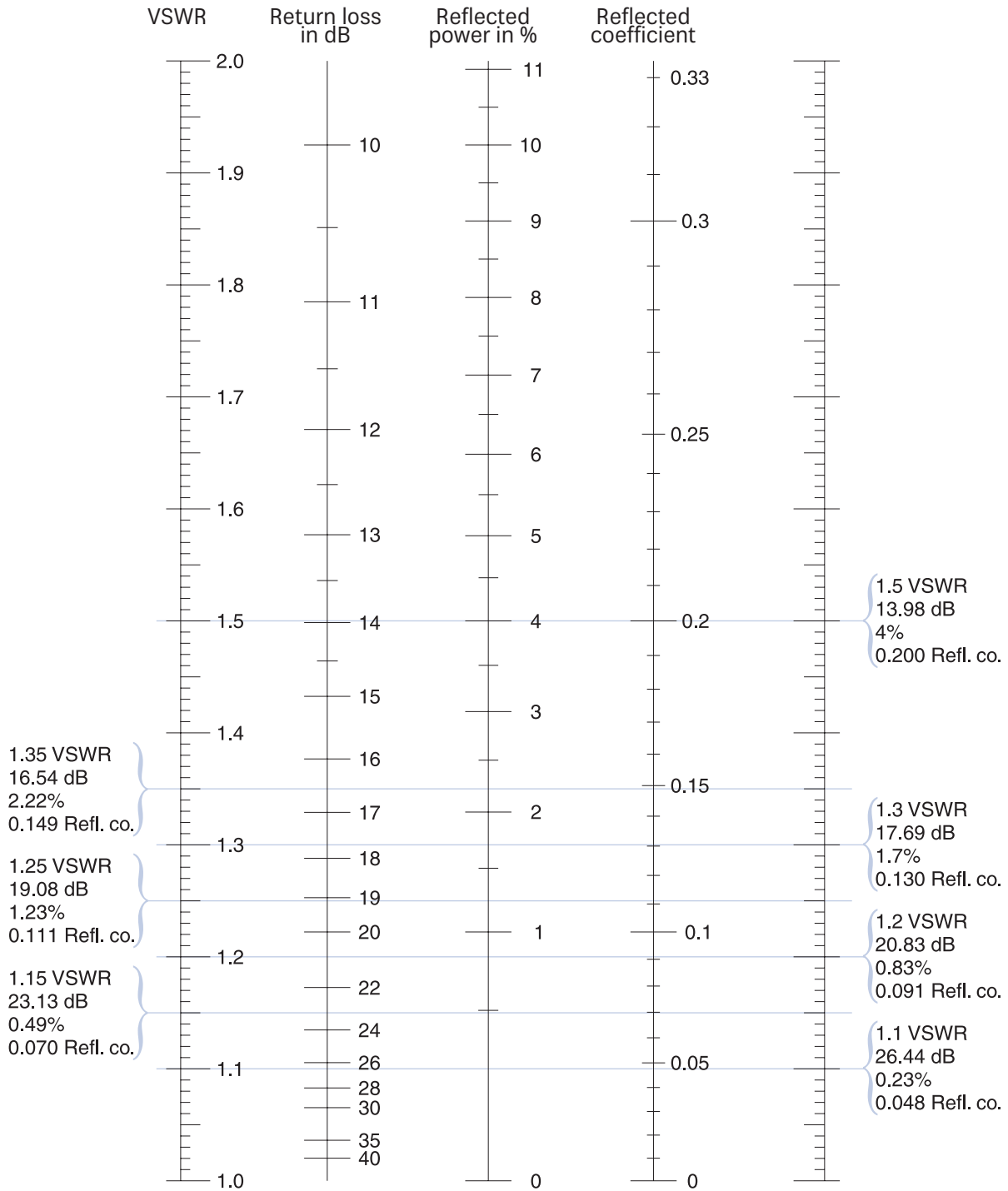

Locate the known value on the appropriate scale, then read across horizontally to find the equivalent values as shown in the examples above.

The following information is required to design an optimum antenna system for you:

Company information:

Company name:

Contact person:

Address:

Phone:

Fax:

E-mail:

Station information:

Station name:

Coordinates:

Station height (m):

Antenna height (m):

Project information:

Polarization: Horizontal Vertical Slant Circular Elliptical

Frequency (MHz) or channels:

Transmitter power (kW):

Min. power rating for system (kW):

Analog

Digital

Antenna gain:

Number of bays:

ERP:

Combiner: Yes No

Direct Access Unit: Yes No

Patch panel: Yes No

Half antenna mode No

Half power

Full power

1 Feeder

2 Feeders

Horizontal Radiation Pattern:

Omnidirectional or directional
(if directional specify requirements)

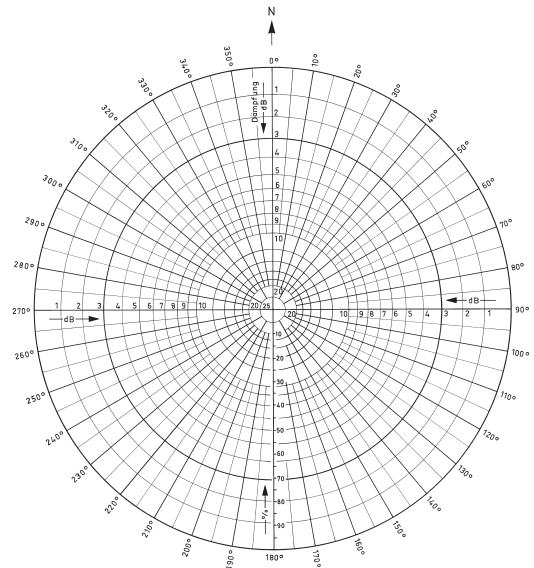

Vertical Radiation Pattern:

Beam tilt (in degrees):

Null-fill (in %):

Tower / Mast:

Square Triangular Round Pipe mast

Azimuth direction of tower face:

Side length or diameter:

Vertical antenna aperture:

Feeder cable:

Air Foam

Size:

Connectors:

Length (m):

Dehydrator: Yes No

Remarks:

e.g. special climatic conditions

Please contact: KATHREIN Broadcast GmbH | broadcast@kathrein.de
Fax +49 8031 184-495 | Ing.-Anton-Kathrein-Str. 1, 3, 5, 7 | 83101 Rohrdorf, Germany

Example for UHF Steel Carrier

KATHREIN has designed special solutions to combine maximum climbing space and safety with optimum horizontal pattern performance. Although very stringent technical specifications of some broadcasters require larger climbing areas, KATHREIN demonstrated that safe climbing and rescue is possible and was able to get approval for its solutions.

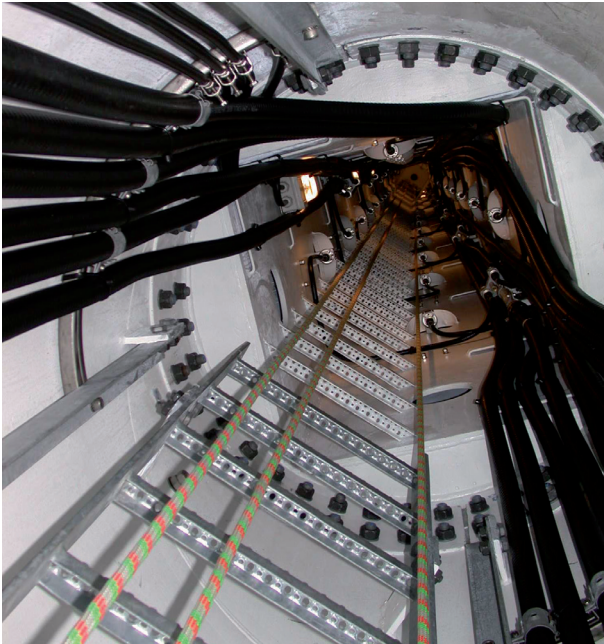

“Stacked Aperture” Configuration Examples

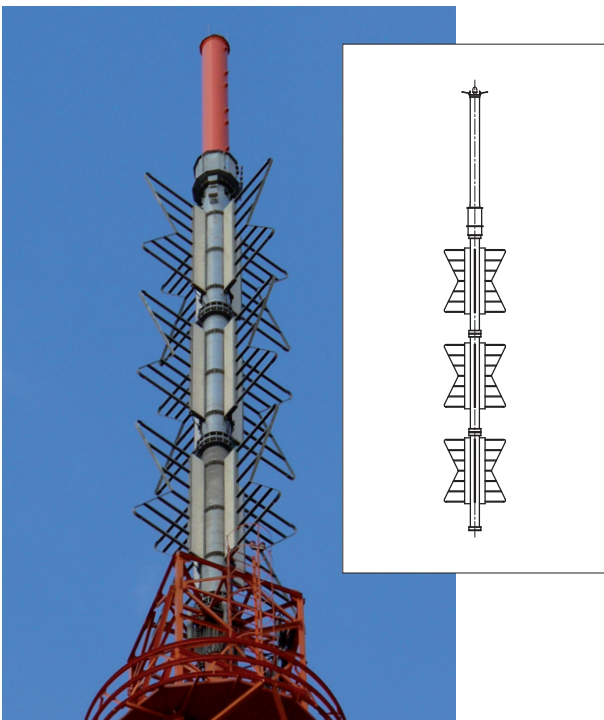

UHF Superturnstile (6 bays) in radome on top of VHF Band I Superturnstile (3 bays)

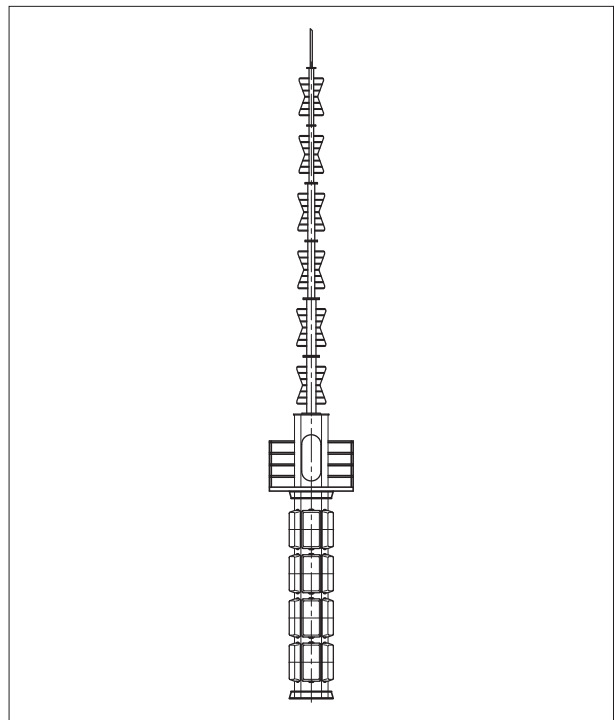

VHF Band III Superturnstile (6 bays) on top of pentagonal UHF panel antenna (4 bays)

KATHREIN Broadcast GmbH
Ing.-Anton-Kathrein-Str. 1, 3, 5, 7
83101 Rohrdorf, Germany
www.kathrein-bca.com
broadcast@kathrein.de