

LFC24-3-S US Damper Actuator Technical Data Sheet

On/Off, Floating Point, Spring Return, 24 V, Trane Voyager Retrofit



Technical Data	
Power Supply	24 VAC, ±20%, 50/60 Hz, 24 VDC, ±10%
Power consumption in operation	2.5 W
Power consumption in rest position	1 W
Transformer sizing	5 VA (class 2 power source)
Shaft Diameter	3/8...1/2" round, centers on 1/2"
Electrical Connection	(2) 18 GA appliance cables with 1/2" conduit connectors, 3 ft [1 m],
Overload Protection	electronic throughout 0...95° rotation
Electrical Protection	actuators are double insulated
Input Impedance	1000 Ω (0.6 W)
Angle of rotation	Max. 95°, adjustable with mechanical stop
Torque motor	35 in-lb [4 Nm]
Direction of motion motor	selectable with switch 0/1
Direction of motion fail-safe	reversible with cw/ccw mounting
Position indication	Mechanical
Running Time (Motor)	90 s
Running time fail-safe	<25 s @ -4...122°F [-20...50°C], <60 s @ -22°F [-30°C]
Ambient humidity	max. 95% r.H., non-condensing
Ambient temperature	-22...122°F [-30...50°C]
Storage temperature	-40...176°F [-40...80°C]
Degree of Protection	IP54, NEMA 2, UL Enclosure Type 2
Housing material	galvanized steel
Agency Listing	cULus acc. To UL 873 and CAN/CSA C22.2 No. 24-93
Noise level, motor	30 dB(A)
Noise level, fail-safe	62 dB(A)
Servicing	maintenance-free
Quality Standard	ISO 9001
Weight	3.5 lb [1.6 kg]
Auxiliary switch	1 x SPDT, 3 A resistive (0.5 A inductive) @ AC 250 V, adjustable 0...95°

†Rated Impulse Voltage 800V, Type of Action 1.AA.B, Control Pollution Degree 3.

Torque min. 35 in-lb, for control of air dampers.

Application

For modulation or On/Off, fail-safe control of dampers in HVAC systems. Actuator sizing should be done in accordance with the damper manufacturer's specifications. The actuator is mounted directly to a damper shaft from 3/8" up to 1/2" in diameter by means of its universal clamp, 1/2" shaft centered at delivery. For shafts up to 3/4" use K6-1 accessory. The ZG-LFC114 universal mounting kit can be used with the LFC24-3-S US actuator for retrofit of the economizer section of the Trane Voyager unit. Control is floating point from a triac or relay, or On/Off from an auxiliary contact from a fan motor contactor, controller or manual switch.

Operation

The LF series actuators provide true spring return operation for reliable fail-safe application and positive close-off on air tight dampers. The spring return system provides consistent torque to the damper with, and without, power applied to the actuator. The LF series provides 95° of rotation and is provided with a graduated position indicator showing 0 to 95°. The LFC24-3-S US uses a brushless DC motor which is controlled by an Application Specific Integrated Circuit (ASIC) and a microprocessor. The microprocessor provides the intelligence to the ASIC to provide a constant rotation rate. The ASIC monitors and controls the brushless DC motor's rotation and provides a digital rotation sensing function to prevent damage to the actuator in a stall condition. The actuator may be stalled anywhere in its normal rotation without the need of mechanical end switches. Power consumption is reduced in holding mode. The LFC24-3-S US version is provided with one built-in auxiliary switch. This SPDT switch is provided for safety interfacing or signaling, for example, for fan start-up. The switching function is adjustable between 0° and 95°. The auxiliary switch in the LFC24-3-S US is double insulated so an electrical ground is not necessary.

Dimensions (Inches[mm])

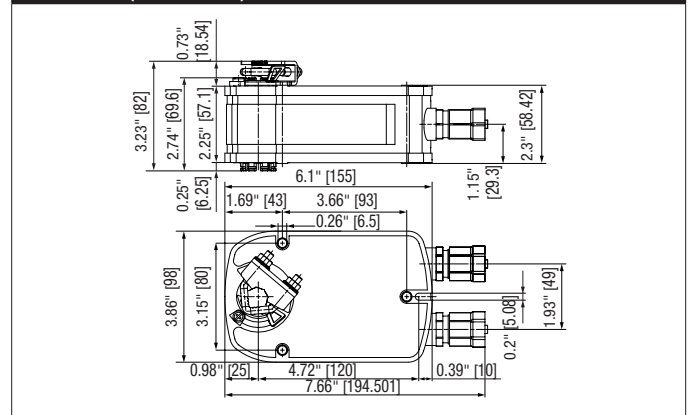

Date created, 02/10/2020 - Subject to change. © Belimo Aircontrols (USA), Inc.

Accessories	
20477-00001	Honeywell logic module bracket.
AV6-20	Shaft extension
K6 US	Standard LF clamp (3/8" to 1/2").
K6-1	Shaft clamp reversible
KG10A	Ball joint
KG8	Ball joint
KH8	Damper crank arm
KH-LF	Actuator arm
KH-LFV	V-bolt Kit for KH-LF.
LF-P	Anti-rotation bracket LF.
SH10	Push rod for KG10A ball joint (36" L, 3/8" diameter).
SH8	Push rod for KG6 & KG8 ball joints (36" L, 5/16" diameter).
TOOL-06	8 mm and 10 mm wrench.
ZDB-LF	Angle of rotation limiter
ZF8-LF	Form fit adapter
ZG-109	Right angle bracket for ZS-260.
ZG-110	Stand-off bracket for ZS-260.
ZG-112	LF right angle bracket 4-1/2x5-1/2x2-1/2" (HxWxD).
ZG-DC1	Damper clip for damper blade, 3.5" width.
ZG-DC2	Damper clip for damper blade, 6" width.
ZG-ECON1	Honeywell ECON retrofit kit with module bracket.
ZG-ECON2	Honeywell ECON retrofit kit without module bracket.
ZG-LF112	LF crankarm adaptor kit (includes ZG-112).
ZG-LF2	LF crankarm adaptor kit (T bracket included).
ZG-LFC114	LF Trane Voyager retrofit kit (incl. bracket and hardware).
ZG-LMSA-1	Shaft extension for 3/8" diameter shafts (4" L).
ZG-LMSA-1/2-5	Shaft extension for 1/2" diameter shafts (5" L).
ZS-100	Weather shield - galvanneal 13x8x6" (LxWxD).
ZS-101	Base plate for ZS-100.
ZS-150	Weather shield - PC w/ foam seal 16x8-3/8x4" (LxWxD).
ZS-260	Explosion proof housing.
ZS-300	NEMA 4X, 304 stainless steel enclosure.
ZS-300-5	NEMA 4X, 316L stainless steel enclosure.
ZS-300-C1	1/2" shaft adaptor, standard with ZS-300(-5).
ZS-300-C2	3/4" shaft adaptor for ZS-300(-5).
P475	Shaft mount, non-Mercury aux. switch for 1/2" dia. shafts.
P475-1	Shaft mount, non-Mercury aux. switch for 1" dia. shafts.
PS-100	Low voltage and control signal simulator.
ZG-CBLS	Electrical junction box for LF.
ZG-X40	120 to 24 VAC, 40 VA transformer.

Typical Specification



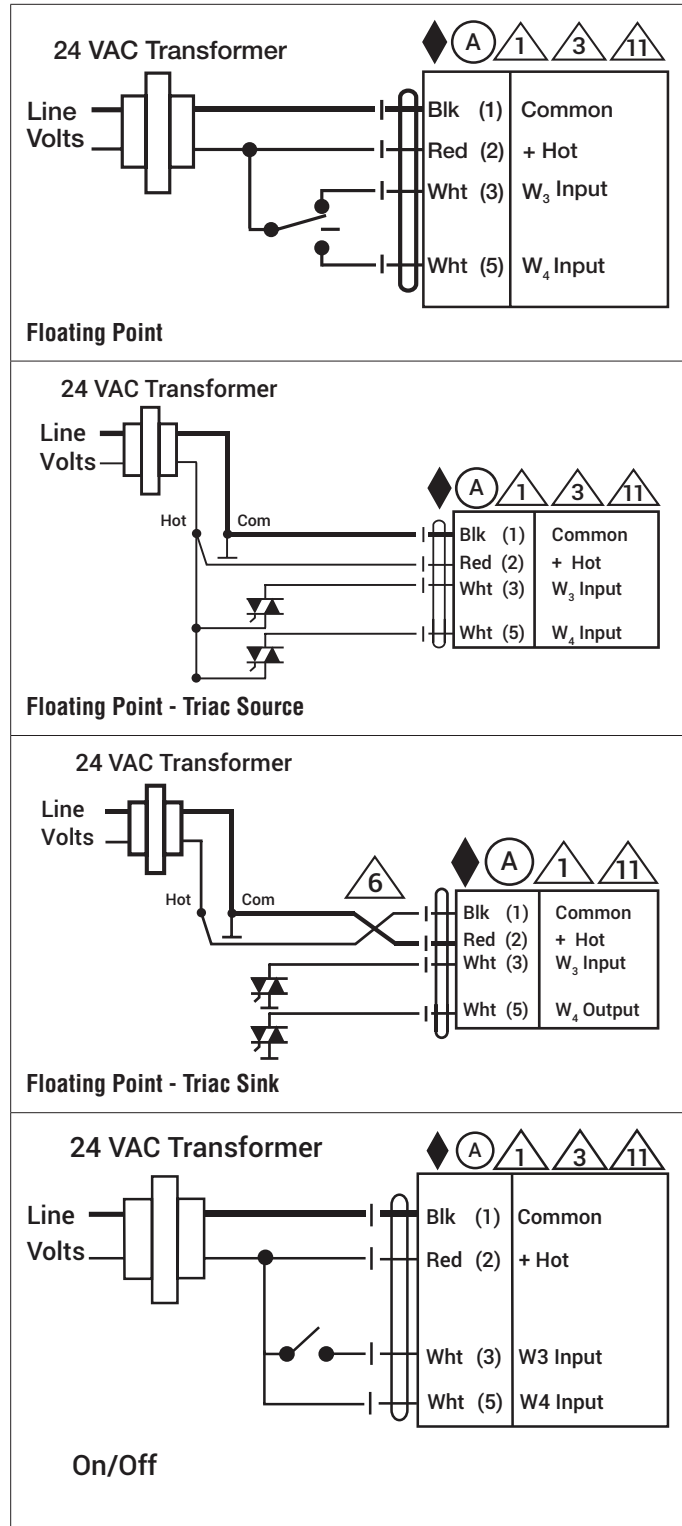





Floating point, On/Off spring return damper actuators shall be direct coupled type which require no crank arm and linkage and be capable of direct mounting to a shaft up to a 3/4" diameter and centers on a 1/2" shaft (default). The actuators must be designed so that they may be used for either clockwise or counter clockwise fail-safe operation. Actuators shall have an external direction of rotation switch to reverse control logic. Actuators shall use a brushless DC motor and be protected from overload at all angles of rotation. If required, one SPDT auxiliary switch shall be provided having the capability of being adjustable. Actuators with auxiliary switch must be constructed to meet the requirements for Double Insulation so an electrical ground is not required to meet agency listings. Run time shall be constant and independent of torque. Actuators shall be cULus listed, have a 5 year warranty, and be manufactured under ISO 9001 International Quality Control Standards. Actuators shall be as manufactured by Belimo.



LFC24-3-S US Damper Actuator Technical Data Sheet

On/Off, Floating Point, Spring Return, 24 V, Trane Voyager Retrofit

Wiring Diagrams

-  **WARNING! LIVE ELECTRICAL COMPONENTS!**
During installation, testing, servicing and troubleshooting of this product, it may be necessary to work with live electrical components. Have a qualified licensed electrician or other individual who has been properly trained in handling live electrical components perform these tasks. Failure to follow all electrical safety precautions when exposed to live electrical components could result in death or serious injury.
-  Meets cULus requirements without the need of an electrical ground connection.
-  Apply only AC line voltage or only UL-Class 2 voltage to the terminals of auxiliary switches. Mixed or combined operation of line voltage/safety extra low voltage is not allowed.
-  Actuators with appliance cables are numbered.
-  Provide overload protection and disconnect as required.
-  Actuators may also be powered by 24 VDC.
-  Actuators Hot wire must be connected to the control board common. Only connect common to neg. (-) leg of control circuits. Terminal models (-T) have no-feedback.
-  Actuators may be connected in parallel if not mechanically linked. Power consumption and input impedance must be observed.
-  One built-in auxiliary switch (1x SPDT), for end position indication, interlock control, fan startup, etc.

