



HIGH SPEED 2K X 8 DUAL-PORT STATIC RAM WITH INTERRUPTS

**IDT71321SA/LA
IDT71421SA/LA**

LEAD FINISH (SnPb) ARE IN EOL PROCESS - LAST TIME BUY EXPIRES JUNE 15, 2018

Features

- ◆ **High-speed access**
 - Commercial: 20/25/35/55ns (max.)
 - Industrial: 25/55ns (max.)
- ◆ **Low-power operation**
 - IDT71321/IDT71421SA
Active: 325mW (typ.)
Standby: 5mW (typ.)
 - IDT71321/421LA
Active: 325mW (typ.)
Standby: 1mW (typ.)
- ◆ **Two \overline{INT} flags for port-to-port communications**
- ◆ **MASTER IDT71321 easily expands data bus width to 16-or-more-bits using SLAVE IDT71421**
- ◆ **On-chip port arbitration logic (IDT71321 only)**
- ◆ **BUSY output flag on IDT71321; \overline{BUSY} input on IDT71421**
- ◆ **Fully asynchronous operation from either port**
- ◆ **Battery backup operation – 2V data retention (LA only)**
- ◆ **TTL-compatible, single 5V \pm 10% power supply**
- ◆ **Available in 52-Pin PLCC, 52-Pin STQFP, 64-Pin TQFP, and 64-Pin STQFP**
- ◆ **Industrial temperature range (-40°C to $+85^{\circ}\text{C}$) is available for selected speeds**
- ◆ **Green parts available, see ordering information**

Functional Block Diagram

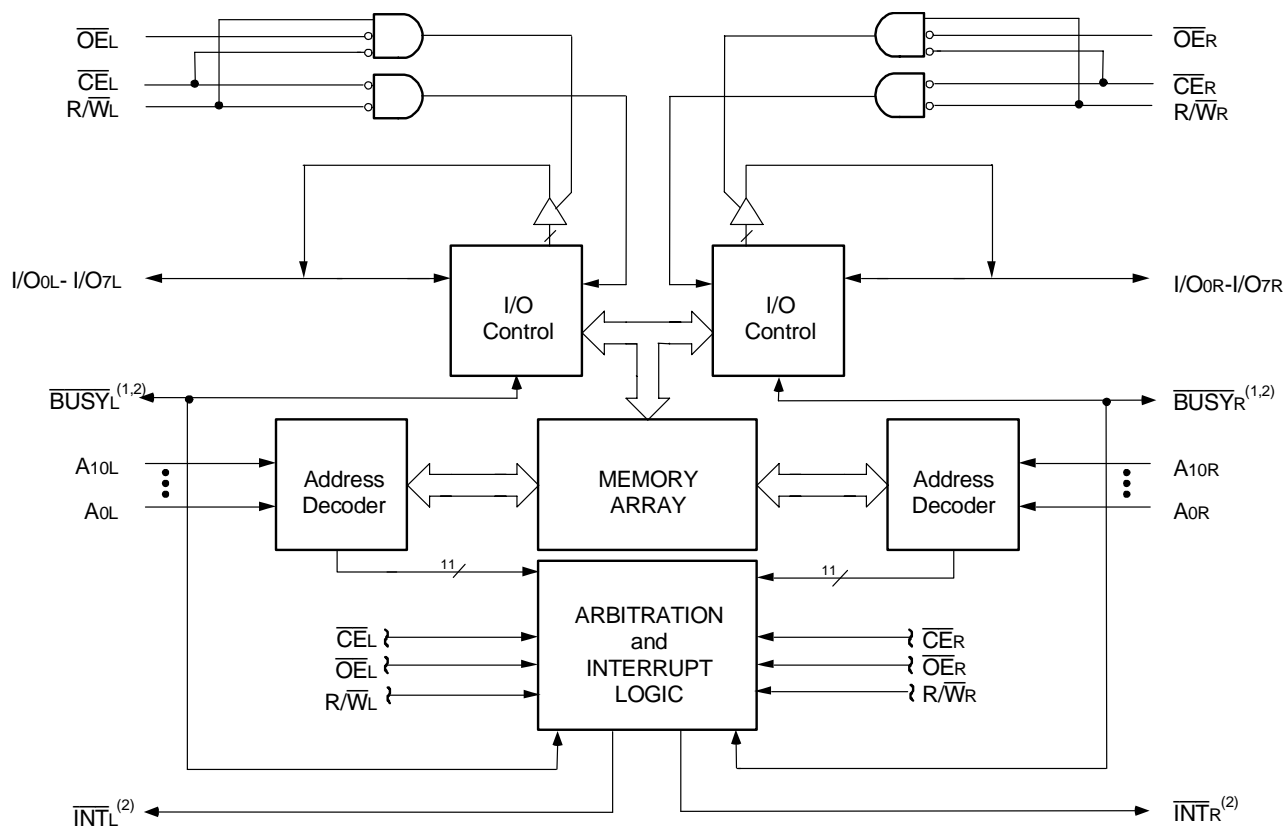

NOTES:

1. IDT71321 (MASTER): \overline{BUSY} is open drain output and requires pullup resistor of 270 Ω .
IDT71421 (SLAVE): \overline{BUSY} is input.
2. Open drain output: requires pullup resistor of 270 Ω .

2691 drw 01

FEBRUARY 2018

Description

The IDT71321/IDT71421 are high-speed 2K x 8 Dual-Port Static RAMs with internal interrupt logic for interprocessor communications. The IDT71321 is designed to be used as a stand-alone 8-bit Dual-Port Static RAM or as a "MASTER" Dual-Port Static RAM together with the IDT71421 "SLAVE" Dual-Port in 16-bit-or-more word width systems. Using the IDT MASTER/SLAVE Dual-Port Static RAM approach in 16-or-more-bit memory system applications results in full speed, error-free operation without the need for additional discrete logic.

Both devices provide two independent ports with separate control,

address, and I/O pins that permit independent, asynchronous access for reads or writes to any location in memory. An automatic power down feature, controlled by \overline{CE} , permits the on chip circuitry of each port to enter a very low standby power mode.

Fabricated using CMOS high-performance technology, these devices typically operate on only 325mW of power. Low-power (LA) versions offer battery backup data retention capability, with each Dual-Port typically consuming 200 μ W from a 2V battery.

The IDT71321/IDT71421 devices are packaged in 52-pin PLCC, 52-pin STQFP, 64-pin TQFP, and 64-pin STQFP.

Pin Configurations^(1,2,3)

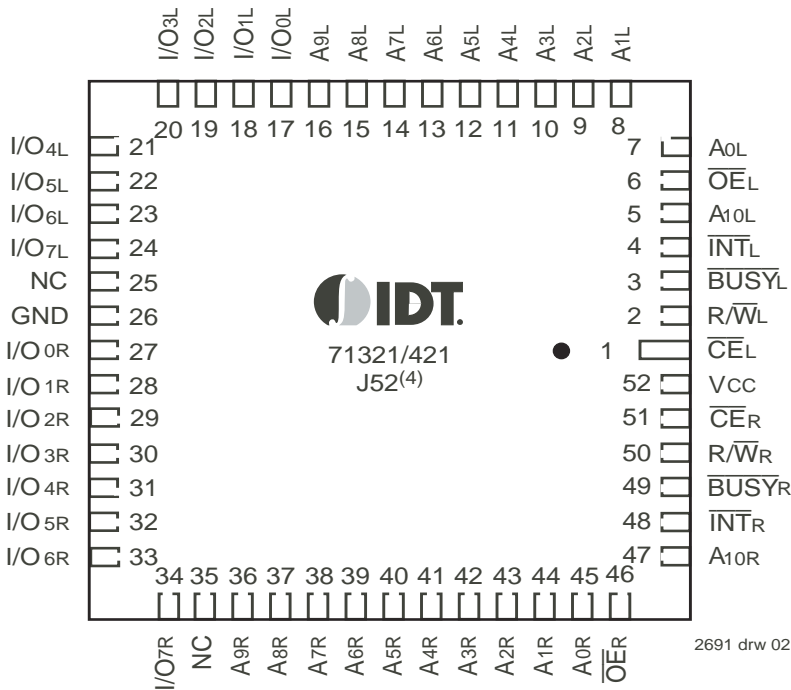

2691 drw 02

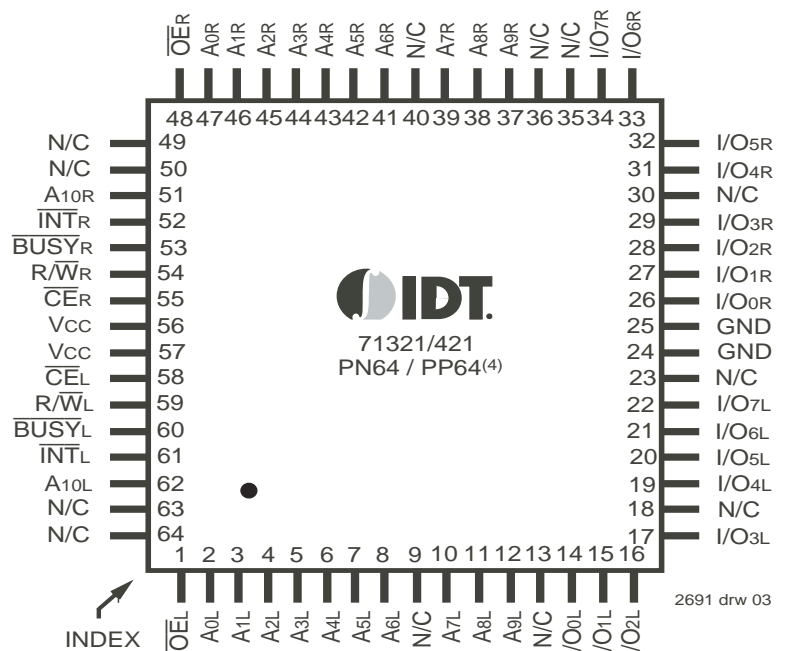

2691 drw 03

NOTES:

1. All Vcc pins must be connected to power supply.
2. All GND pins must be connected to ground supply.
3. J52 package body is approximately .75in x .75in x .17in.
 PN64 package body is approximately 14mm x 14mm x 1.4mm.
 PP64 package body is approximately 10mm x 10mm x 1.4mm.
4. This package code is used to reference the package diagram.

Pin Configurations (continued)^(1,2,3)

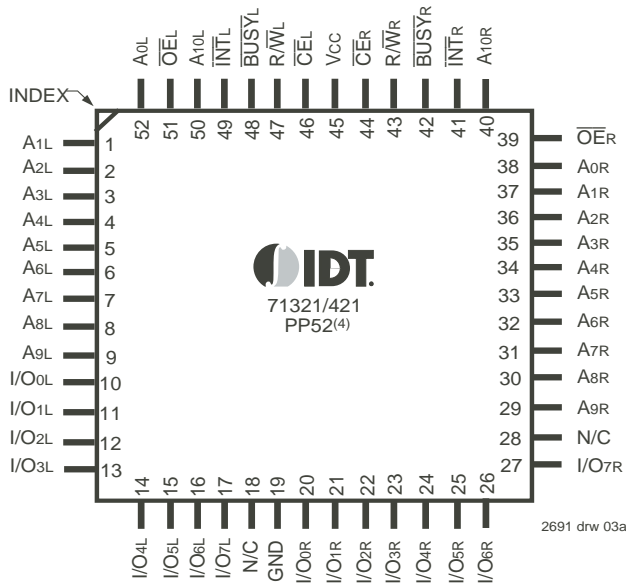

NOTES:

1. All Vcc pins must be connected to power supply.
2. All GND pins must be connected to ground supply.
3. PP52 package body is approximately 10mm x 10mm x 1.4mm.
4. This package code is used to reference the package diagram.

Capacitance⁽¹⁾ (TA = +25°C, f = 1.0MHz) TQFP Only

Symbol	Parameter	Conditions ⁽²⁾	Max.	Unit
C _{IN}	Input Capacitance	V _{IN} = 3dV	9	pF
C _{OUT}	Output Capacitance	V _{OUT} = 3dV	10	pF

NOTES:

1. This parameter is determined by device characterization but is not production tested.
2. 3dV references the interpolated capacitance when the input and output signals switch from 0V to 3V or from 3V to 0V.

Absolute Maximum Ratings⁽¹⁾

Symbol	Rating	Commercial & Industrial	Unit
V _{TERM} ⁽²⁾	Terminal Voltage with Respect to GND	-0.5 to +7.0	V
T _{BIAS}	Temperature Under Bias	-55 to +125	°C
T _{STG}	Storage Temperature	-65 to +150	°C
I _{OUT}	DC Output Current	50	mA

NOTES:

1. Stresses greater than those listed under ABSOLUTE MAXIMUM RATINGS may cause permanent damage to the device. This is a stress rating only and functional operation of the device at these or any other conditions above those indicated in the operational sections of the specification is not implied. Exposure to absolute maximum rating conditions for extended periods may affect reliability.
2. V_{TERM} must not exceed V_{CC} + 10% for more than 25% of the cycle time or 10ns maximum, and is limited to ≤ 20mA for the period of V_{TERM} ≥ V_{CC} + 10%.

Recommended Operating Temperature and Supply Voltage^(1,2)

Grade	Ambient Temperature	GND	Vcc
Commercial	0°C to +70°C	0V	5.0V ± 10%
Industrial	-40°C to +85°C	0V	5.0V ± 10%

NOTES:

1. This is the parameter TA. This is the "instant on" case temperature.
2. Industrial temperature: for specific speeds, packages and powers contact your sales office.

Recommended DC Operating Conditions

Symbol	Parameter	Min.	Typ.	Max.	Unit
V _{CC}	Supply Voltage	4.5	5.0	5.5	V
GND	Ground	0	0	0	V
V _{IH}	Input High Voltage	2.2	—	6.0 ⁽²⁾	V
V _{IL}	Input Low Voltage	-0.5 ⁽¹⁾	—	0.8	V

NOTES:

1. V_{IL} (min.) = -1.5V for pulse width less than 10ns.
2. V_{TERM} must not exceed V_{CC} + 10%.

DC Electrical Characteristics Over the Operating Temperature and Supply Voltage Range^(1,4) (V_{CC} = 5.0V ± 10%)

Symbol	Parameter	Test Condition	Version		71321X20 71421X20 Com'l Only		71321X25 71421X25 Com'l & Ind		Unit
					Typ.	Max.	Typ.	Max.	
I _{CC}	Dynamic Operating Current (Both Ports Active)	\overline{CE}_L and $\overline{CE}_R = V_{IL}$, Outputs Disabled $f = f_{MAX}^{(2)}$	COM'L	SA	110	250	110	220	mA
				LA	110	200	110	170	
I _{SB1}	Standby Current (Both Ports - TTL Level Inputs)	\overline{CE}_L and $\overline{CE}_R = V_H$ $f = f_{MAX}^{(2)}$	COM'L	SA	30	65	30	65	mA
				LA	30	45	30	45	
I _{SB2}	Standby Current (One Port - TTL Level Inputs)	$\overline{CE}^*A = V_{IL}$ and $\overline{CE}^*B = V_H^{(5)}$ Active Port Outputs Disabled, $f = f_{MAX}^{(2)}$	COM'L	SA	65	165	65	150	mA
				LA	65	125	65	115	
I _{SB3}	Full Standby Current (Both Ports - CMOS Level Inputs)	\overline{CE}_L and $\overline{CE}_R \geq V_{CC} - 0.2V$, $V_{IN} > V_{CC} - 0.2V$ or $V_{IN} \leq 0.2V$, $f = 0^{(3)}$	COM'L	SA	1.0	15	1.0	15	mA
				LA	0.2	5	0.2	5	
I _{SB4}	Full Standby Current (One Port - CMOS Level Inputs)	$\overline{CE}^*A < 0.2V$ and $\overline{CE}^*B > V_{CC} - 0.2V^{(5)}$ $V_{IN} \geq V_{CC} - 0.2V$ or $V_{IN} \leq 0.2V$ Active Port Outputs Disabled, $f = f_{MAX}^{(2)}$	COM'L	SA	60	155	60	145	mA
				LA	60	115	60	105	

2691 tbl 04a

Symbol	Parameter	Test Condition	Version		71321X35 71421X35 Com'l Only		71321X55 71421X55 Com'l & Ind		Unit
					Typ.	Max.	Typ.	Max.	
I _{CC}	Dynamic Operating Current (Both Ports Active)	\overline{CE}_L and $\overline{CE}_R = V_{IL}$, Outputs Disabled $f = f_{MAX}^{(2)}$	COM'L	SA	80	165	65	155	mA
				LA	80	120	65	110	
I _{SB1}	Standby Current (Both Ports - TTL Level Inputs)	\overline{CE}_L and $\overline{CE}_R = V_H$ $f = f_{MAX}^{(2)}$	COM'L	SA	25	65	20	65	mA
				LA	25	45	20	35	
I _{SB2}	Standby Current (One Port - TTL Level Inputs)	$\overline{CE}^*A = V_{IL}$ and $\overline{CE}^*B = V_H^{(5)}$ Active Port Outputs Disabled, $f = f_{MAX}^{(2)}$	COM'L	SA	50	125	40	110	mA
				LA	50	90	40	75	
I _{SB3}	Full Standby Current (Both Ports - CMOS Level Inputs)	\overline{CE}_L and $\overline{CE}_R \geq V_{CC} - 0.2V$, $V_{IN} > V_{CC} - 0.2V$ or $V_{IN} \leq 0.2V$, $f = 0^{(3)}$	COM'L	SA	1.0	15	1.0	15	mA
				LA	0.2	4	0.2	4	
I _{SB4}	Full Standby Current (One Port - CMOS Level Inputs)	$\overline{CE}^*A < 0.2V$ and $\overline{CE}^*B > V_{CC} - 0.2V^{(5)}$ $V_{IN} \geq V_{CC} - 0.2V$ or $V_{IN} \leq 0.2V$ Active Port Outputs Disabled, $f = f_{MAX}^{(2)}$	COM'L	SA	45	110	40	100	mA
				LA	45	85	40	70	

2691 tbl 04b

NOTES:

- 'X' in part numbers indicates power rating (SA or LA).
- At $f = f_{MAX}$, address and control lines (except Output Enable) are cycling at the maximum frequency read cycle of $1/t_{rc}$, and using "AC TEST CONDITIONS" of input levels of GND to 3V.
- $f = 0$ means no address or control lines change. Applies only to inputs at CMOS level standby.
- $V_{CC} = 5V$, $T_A = +25^\circ C$ for Typ and is not production tested. $V_{CC DC} = 100mA$ (Typ)
- Port "A" may be either left or right port. Port "B" is opposite from port "A".

DC Electrical Characteristics Over the Operating Temperature and Supply Voltage Range ($V_{CC} = 5.0V \pm 10\%$)

Symbol	Parameter	Test Conditions	71321SA 71421SA		71321LA 71421LA		Unit
			Min.	Max.	Min.	Max.	
$ I_{LI} $	Input Leakage Current ⁽¹⁾	$V_{CC} = 5.5V, V_{IN} = 0V \text{ to } V_{CC}$	—	10	—	5	μA
$ I_{LO} $	Output Leakage Current ⁽¹⁾	$\overline{CE} = V_{IH}, V_{OUT} = 0V \text{ to } V_{CC}, V_{CC} = 5.5V$	—	10	—	5	μA
V_{OL}	Output Low Voltage (I_{O0} - I_{O7})	$I_{OL} = 4mA$	—	0.4	—	0.4	V
V_{OL}	Open Drain Output Low Voltage ($\overline{BUSY}/\overline{INT}$)	$I_{OL} = 16mA$	—	0.5	—	0.5	V
V_{OH}	Output High Voltage	$I_{OH} = -4mA$	2.4	—	2.4	—	V

2691 tbl 05

NOTE:

- At $V_{CC} \leq 2.0V$ leakages are undefined.

Data Retention Characteristics (LA Version Only)

Symbol	Parameter	Test Condition	Min.	Typ. ⁽¹⁾	Max.	Unit	
V_{DR}	V_{CC} for Data Retention		2.0	—	0	V	
I_{CCDR}	Data Retention Current	$V_{CC} = 2.0V, \overline{CE} \geq V_{CC} - 0.2V$ $V_{IN} \geq V_{CC} - 0.2V \text{ or } V_{IN} \leq 0.2V$	COM'L	—	100	1500	μA
			IND	—	100	4000	μA
$t_{CDR}^{(3)}$	Chip Deselect to Data Retention Time		0	—	—	ns	
$t_R^{(3)}$	Operation Recovery Time		$t_{RC}^{(2)}$	—	—	ns	

2691 tbl 06

NOTES:

- $V_{CC} = 2V, T_A = +25^\circ C$, and is not production tested.
- t_{RC} = Read Cycle Time
- This parameter is guaranteed but not production tested.

Data Retention Waveform

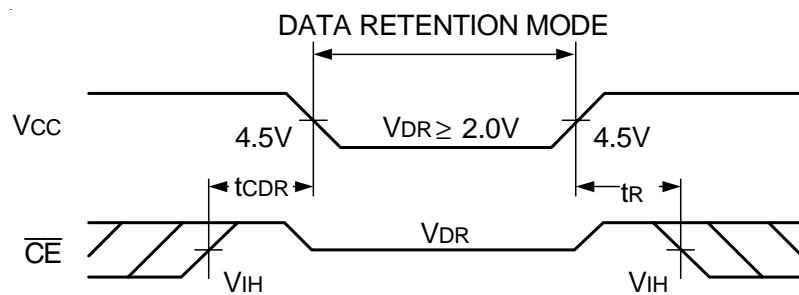

2691 drw 04

AC Test Conditions

Input Pulse Levels	GND to 3.0V
Input Rise/Fall Times	5ns
Input Timing Reference Levels	1.5V
Output Reference Levels	1.5V
Output Load	Figures 1,2 and 3

2691 tbl 07

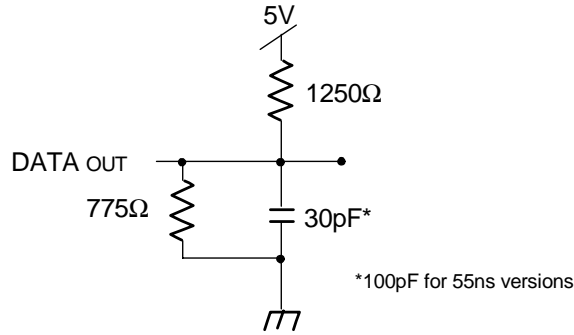

Figure 1. AC Output Test Load

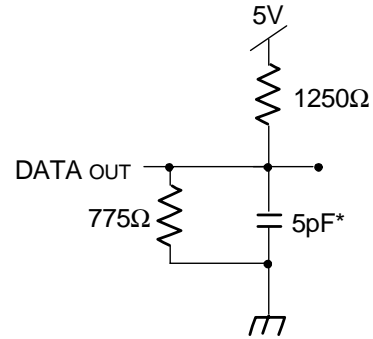

Figure 2. Output Test Load
(for t_{Hz}, t_{LZ}, t_{wZ}, and t_{ow})
* Including scope and jig.

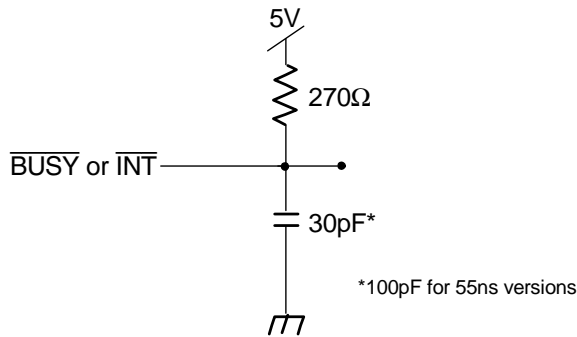

Figure 3. $\overline{\text{BUSY}}$ and $\overline{\text{INT}}$
AC Output Test Load

2691 drw 05

AC Electrical Characteristics Over the Operating Temperature Supply Voltage Range⁽²⁾

Symbol	Parameter	71321X20 71421X20 Com'l Only		71321X25 71421X25 Com'l & Ind		Unit
		Min.	Max.	Min.	Max.	
READ CYCLE						
t _{RC}	Read Cycle Time	20	—	25	—	ns
t _{AA}	Address Access Time	—	20	—	25	ns
t _{ACE}	Chip Enable Access Time	—	20	—	25	ns
t _{AOE}	Output Enable Access Time	—	11	—	12	ns
t _{OH}	Output Hold from Address Change	3	—	3	—	ns
t _{LZ}	Output Low-Z Time ^(1,3)	0	—	0	—	ns
t _{HZ}	Output High-Z Time ^(1,3)	—	10	—	10	ns
t _{PU}	Chip Enable to Power Up Time ⁽³⁾	0	—	0	—	ns
t _{PD}	Chip Disable to Power Down Time ⁽³⁾	—	20	—	25	ns

2691 tbl 08a

Symbol	Parameter	71321X35 71421X35 Com'l Only		71321X55 71421X55 Com'l & Ind		Unit
		Min.	Max.	Min.	Max.	
READ CYCLE						
t _{RC}	Read Cycle Time	35	—	55	—	ns
t _{AA}	Address Access Time	—	35	—	55	ns
t _{ACE}	Chip Enable Access Time	—	35	—	55	ns
t _{AOE}	Output Enable Access Time	—	20	—	25	ns
t _{OH}	Output Hold from Address Change	3	—	3	—	ns
t _{LZ}	Output Low-Z Time ^(1,3)	0	—	5	—	ns
t _{HZ}	Output High-Z Time ^(1,3)	—	15	—	25	ns
t _{PU}	Chip Enable to Power Up Time ⁽³⁾	0	—	0	—	ns
t _{PD}	Chip Disable to Power Down Time ⁽³⁾	—	35	—	50	ns

2691 tbl 08b

NOTES:

1. Transition is measured 0mV from Low or High-impedance voltage Output Test Load (Figure 2).
2. 'X' in part numbers indicates power rating (SA or LA).
3. This parameter is guaranteed by device characterization, but is not production tested.

Timing Waveform of Read Cycle No. 1, Either Side⁽¹⁾

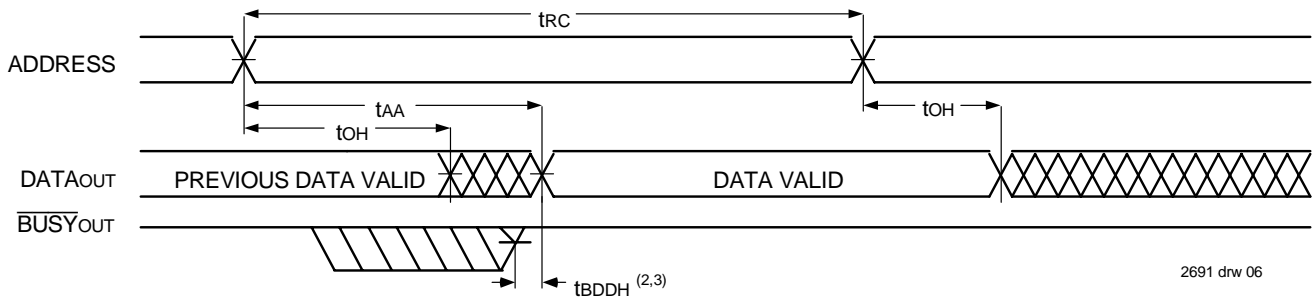

2691 drw 06

NOTES:

1. $R/\bar{W} = V_{IH}$, $\bar{CE} = V_{IL}$, and is $\bar{OE} = V_{IL}$. Address is valid prior to the coincidental with \bar{CE} transition LOW.
2. t_{BDD} delay is required only in the case where the opposite port is completing a write operation to the same address location. For simultaneous read operations $BUSY$ has no relationship to valid output data.
3. Start of valid data depends on which timing becomes effective last t_{AOE} , t_{ACE} , t_{AA} , and t_{BDD} .

Timing Waveform of Read Cycle No. 2, Either Side⁽³⁾

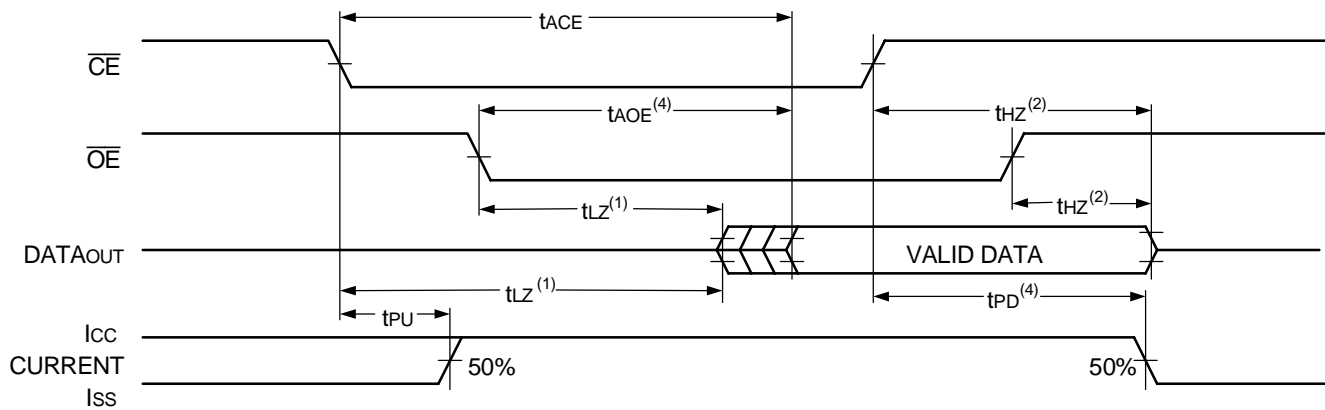

2691 drw 07

NOTES:

1. Timing depends on which signal is asserted last, \bar{OE} or \bar{CE} .
2. Timing depends on which signal is de-asserted first, \bar{OE} or \bar{CE} .
3. $R/\bar{W} = V_{IH}$ and $\bar{OE} = V_{IL}$, and the address is valid prior to or coincidental with \bar{CE} transition LOW.
4. Start of valid data depends on which timing becomes effective last t_{AOE} , t_{ACE} , t_{AA} , and t_{BDD} .

AC Electrical Characteristics Over the Operating Temperature and Supply Voltage Range⁽⁴⁾

Symbol	Parameter	71321X20 71421X20 Com'l Only		71321X25 71421X25 Com'l & Ind		Unit
		Min.	Max.	Min.	Max.	
WRITE CYCLE						
t _{wc}	Write Cycle Time ⁽²⁾	20	—	25	—	ns
t _{ew}	Chip Enable to End-of-Write	15	—	20	—	ns
t _{aw}	Address Valid to End-of-Write	15	—	20	—	ns
t _{as}	Address Set-up Time	0	—	0	—	ns
t _{wp}	Write Pulse Width ⁽³⁾	15	—	15	—	ns
t _{wr}	Write Recovery Time	0	—	0	—	ns
t _{dw}	Data Valid to End-of-Write	10	—	12	—	ns
t _{hz}	Output High-Z Time ⁽¹⁾	—	10	—	10	ns
t _{dh}	Data Hold Time	0	—	0	—	ns
t _{wz}	Write Enable to Output in High-Z ⁽¹⁾	—	10	—	10	ns
t _{ow}	Output Active from End-of-Write ⁽¹⁾	0	—	0	—	ns

2691 tbl 09a

Symbol	Parameter	71321X35 71421X35 Com'l Only		71321X55 71421X55 Com'l & Ind		Unit
		Min.	Max.	Min.	Max.	
WRITE CYCLE						
t _{wc}	Write Cycle Time ⁽²⁾	35	—	55	—	ns
t _{ew}	Chip Enable to End-of-Write	30	—	40	—	ns
t _{aw}	Address Valid to End-of-Write	30	—	40	—	ns
t _{as}	Address Set-up Time	0	—	0	—	ns
t _{wp}	Write Pulse Width ⁽³⁾	25	—	30	—	ns
t _{wr}	Write Recovery Time	0	—	0	—	ns
t _{dw}	Data Valid to End-of-Write	15	—	20	—	ns
t _{hz}	Output High-Z Time ⁽¹⁾	—	15	—	25	ns
t _{dh}	Data Hold Time	0	—	0	—	ns
t _{wz}	Write Enable to Output in High-Z ⁽¹⁾	—	15	—	30	ns
t _{ow}	Output Active from End-of-Write ⁽¹⁾	0	—	0	—	ns

2691 tbl 09b

NOTES:

- Transition is measured 0mV from Low or High-impedance voltage with Output Test Load (Figure 2). This parameter is guaranteed by device characterization but is not production tested.
- For Master/Slave combination, $t_{wc} = t_{BAA} + t_{wp}$, since $R/\overline{W} = V_{IL}$ must occur after t_{BAA} .
- If \overline{OE} is LOW during a R/\overline{W} controlled write cycle, the write pulse width must be the larger of t_{wp} or $(t_{wz} + t_{dw})$ to allow the I/O drivers to turn off data to be placed on the bus for the required t_{dw} . If \overline{OE} is HIGH during a R/\overline{W} controlled write cycle, this requirement does not apply and the write pulse can be as short as the specified t_{wp} .
- 'X' in part numbers indicates power rating (SA or LA).

Timing Waveform of Write Cycle No. 1, ($\overline{R/\overline{W}}$ Controlled Timing)^(1,5,8)

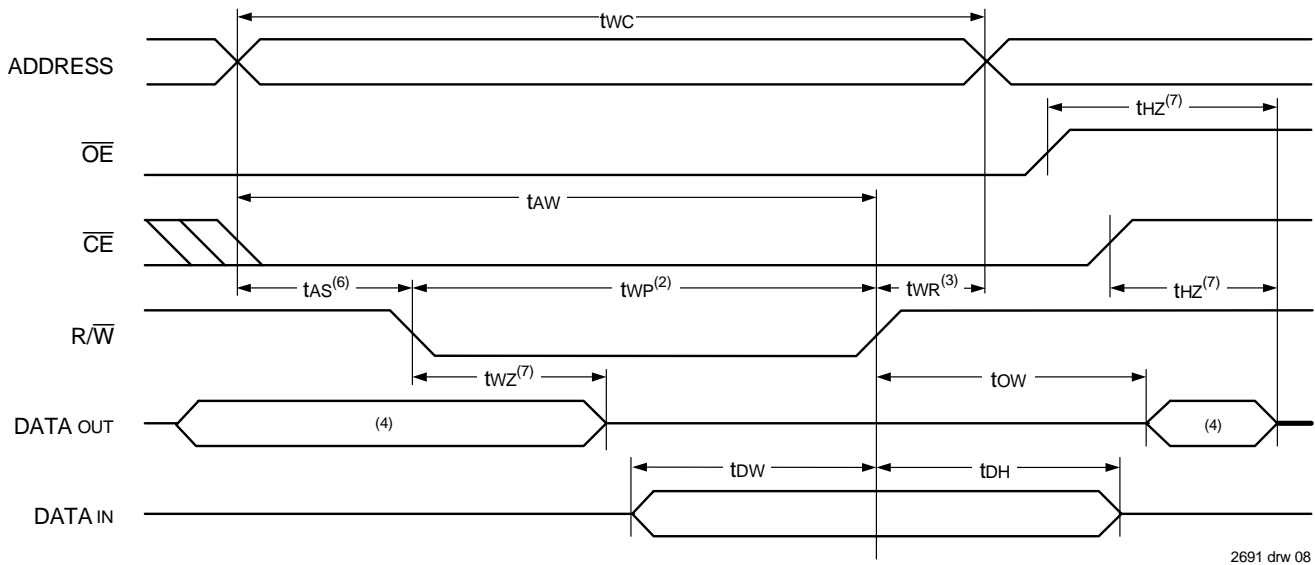

Timing Waveform of Write Cycle No. 2, (\overline{CE} Controlled Timing)^(1,5)

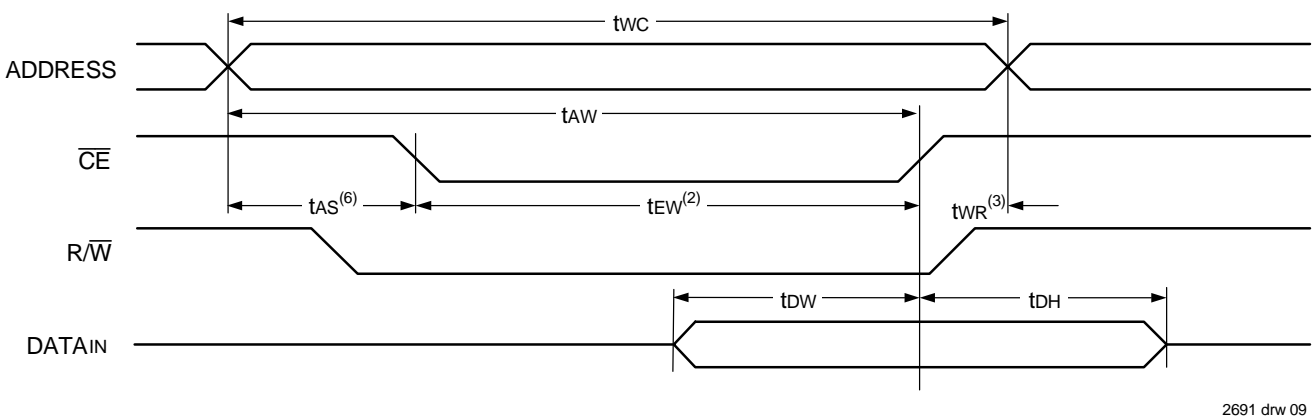

NOTES:

1. $\overline{R/\overline{W}}$ or \overline{CE} must be HIGH during all address transitions.
2. A write occurs during the overlap (t_{EW} or t_{WP}) of $\overline{CE} = V_{IL}$ and $\overline{R/\overline{W}} = V_{IL}$.
3. t_{WR} is measured from the earlier of \overline{CE} or $\overline{R/\overline{W}}$ going HIGH to the end of the write cycle.
4. During this period, the I/O pins are in the output state and input signals must not be applied.
5. If the \overline{CE} LOW transition occurs simultaneously with or after the $\overline{R/\overline{W}}$ LOW transition, the outputs remain in the High-impedance state.
6. Timing depends on which enable signal (\overline{CE} or $\overline{R/\overline{W}}$) is asserted last.
7. This parameter is determined to be device characterization, but is not production tested. Transition is measured 0mV from steady state with the Output Test Load (Figure 2).
8. If \overline{OE} is LOW during a $\overline{R/\overline{W}}$ controlled write cycle, the write pulse width must be the larger of t_{WP} or $(t_{WZ} + t_{DW})$ to allow the I/O drivers to turn off data to be placed on the bus for the required t_{OW} . If \overline{OE} is HIGH during a $\overline{R/\overline{W}}$ controlled write cycle, this requirement does not apply and the write pulse can be as short as the specified t_{WP} .

AC Electrical Characteristics Over the Operating Temperature and Supply Voltage Range⁽⁶⁾

Symbol	Parameter	71321X20 71421X20 Com'1 Only		71321X25 71421X25 Com'1 & Ind		Unit
		Min.	Max.	Min.	Max.	
BUSY TIMING (For MASTER 71321)						
tBAA	$\overline{\text{BUSY}}$ Access Time from Address	---	20	---	20	ns
tBDA	$\overline{\text{BUSY}}$ Disable Time from Address	---	20	---	20	ns
tBAC	$\overline{\text{BUSY}}$ Access Time from Chip Enable	---	20	---	20	ns
tBDC	$\overline{\text{BUSY}}$ Disable Time from Chip Enable	---	20	---	20	ns
tWH	Write Hold After $\overline{\text{BUSY}}^{(6)}$	12	---	15	---	ns
tWDD	Write Pulse to Data Delay ⁽¹⁾	---	50	---	50	ns
tDDD	Write Data Valid to Read Data Delay ⁽¹⁾	---	35	---	35	ns
tAPS	Arbitration Priority Set-up Time ⁽²⁾	5	---	5	---	ns
tBDD	$\overline{\text{BUSY}}$ Disable to Valid Data ⁽³⁾	---	25	---	35	ns
BUSY INPUT TIMING (For SLAVE 71421)						
tWB	Write to $\overline{\text{BUSY}}$ Input ⁽⁴⁾	0	---	0	---	ns
tWH	Write Hold After $\overline{\text{BUSY}}^{(6)}$	12	---	15	---	ns
tWDD	Write Pulse to Data Delay ⁽¹⁾	---	40	---	50	ns
tDDD	Write Data Valid to Read Data Delay ⁽¹⁾	---	30	---	35	ns

2691 tbl 10a

Symbol	Parameter	71321X35 71421X35 Com'1 Only		71321X55 71421X55 Com'1 & Ind		Unit
		Min.	Max.	Min.	Max.	
BUSY TIMING (For MASTER 71321)						
tBAA	$\overline{\text{BUSY}}$ Access Time from Address	---	20	---	30	ns
tBDA	$\overline{\text{BUSY}}$ Disable Time from Address	---	20	---	30	ns
tBAC	$\overline{\text{BUSY}}$ Access Time from Chip Enable	---	20	---	30	ns
tBDC	$\overline{\text{BUSY}}$ Disable Time from Chip Enable	---	20	---	30	ns
tWH	Write Hold After $\overline{\text{BUSY}}^{(6)}$	20	---	20	---	ns
tWDD	Write Pulse to Data Delay ⁽¹⁾	---	60	---	80	ns
tDDD	Write Data Valid to Read Data Delay ⁽¹⁾	---	35	---	55	ns
tAPS	Arbitration Priority Set-up Time ⁽²⁾	5	---	5	---	ns
tBDD	$\overline{\text{BUSY}}$ Disable to Valid Data ⁽³⁾	---	35	---	50	ns
BUSY INPUT TIMING (For SLAVE 71421)						
tWB	Write to $\overline{\text{BUSY}}$ Input ⁽⁴⁾	0	---	0	---	ns
tWH	Write Hold After $\overline{\text{BUSY}}^{(6)}$	20	---	20	---	ns
tWDD	Write Pulse to Data Delay ⁽¹⁾	---	60	---	80	ns
tDDD	Write Data Valid to Read Data Delay ⁽¹⁾	---	35	---	55	ns

2691 tbl 10b

NOTES:

- Port-to-port delay through RAM cells from the writing port to the reading port, refer to "Timing Waveform of Write with Port-to-Port Read and BUSY."
- To ensure that the earlier of the two ports wins.
- tBDD is a calculated parameter and is the greater of 0, tWDD – tWP (actual) or tDDD – tDW (actual).
- To ensure that a write cycle is inhibited on port "B" during contention on port "A".
- To ensure that a write cycle is completed on port "B" after contention on port "A".
- 'X' in part numbers indicates power rating (SA or LA)..

Timing Waveform of Write with Port-to-Port Read and **BUSY**^(2,3,4)

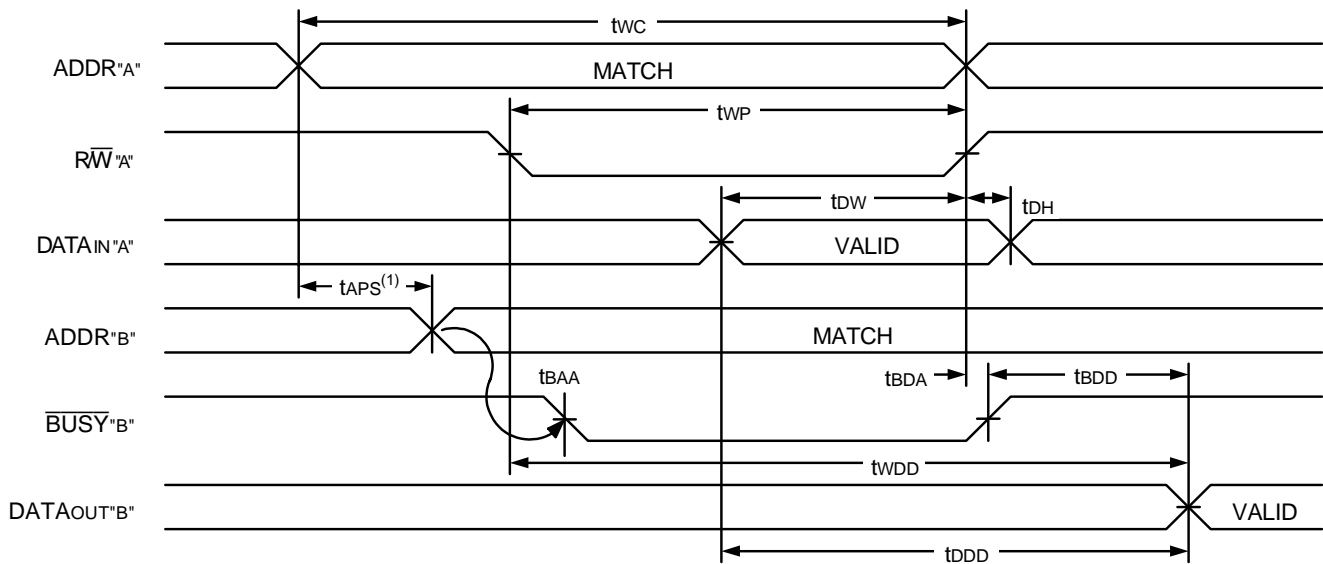

NOTES:

1. To ensure that the earlier of the two ports wins. tAPS is ignored for Slave (IDT71421).
2. $\overline{CE}_L = \overline{CE}_R = V_{IL}$
3. $\overline{OE} = V_{IL}$ for the reading port.
4. All timing is the same for the left and right ports. Port "A" may be either the left or right port. Port "B" is opposite from port "A".

2691 drw 10

Timing Waveform of Write with **BUSY**⁽⁴⁾

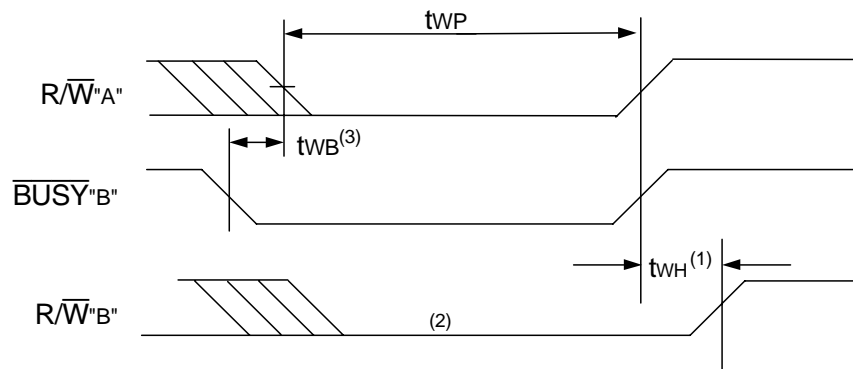

NOTES:

1. tWH must be met for both \overline{BUSY} input (IDT71421, slave) or output (IDT71321, Master).
2. \overline{BUSY} is asserted on port "B" blocking $\overline{R/W}$ "B", until \overline{BUSY} "B" goes HIGH.
3. tWB is only for the slave version (IDT71421).
4. All timing is the same for the left and right ports. Port "A" may be either the left or right port. Port "B" is opposite from port "A".

2691 drw 11

Timing Waveform of $\overline{\text{BUSY}}$ Arbitration Controlled by $\overline{\text{CE}}$ Timing⁽¹⁾

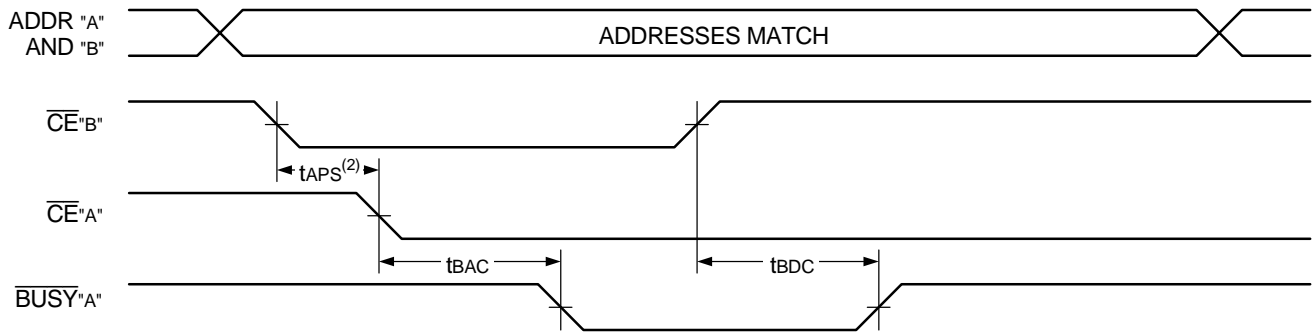

2691 drw 12

Timing Waveform of $\overline{\text{BUSY}}$ Arbitration Controlled by Address Match Timing⁽¹⁾

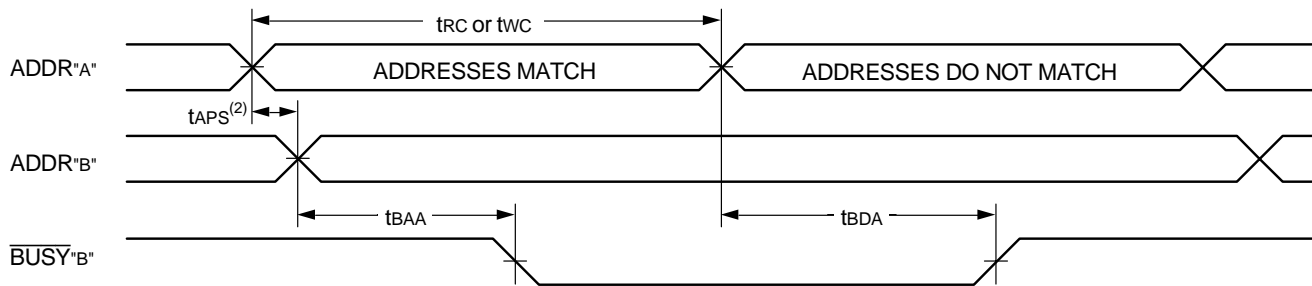

2691 drw 13

NOTES:

1. All timing is the same for left and right ports. Port "A" may be either left or right port. Port "B" is the opposite from port "A".
2. If tAPS is not satisfied, the $\overline{\text{BUSY}}$ will be asserted on one side or the other, but there is no guarantee on which side $\overline{\text{BUSY}}$ will be asserted (IDT71321 only).

AC Electrical Characteristics Over the Operating Temperature and Supply Voltage Range⁽¹⁾

Symbol	Parameter	71321X20 71421X20 Com'l Only		71321X25 71421X25 Com'l & Ind		Unit
		Min.	Max.	Min.	Max.	
INTERRUPT TIMING						
tAS	Address Set-up Time	0	—	0	—	ns
tWR	Write Recovery Time	0	—	0	—	ns
tNS	Interrupt Set Time	—	20	—	25	ns
tNR	Interrupt Reset Time	—	20	—	25	ns

2691 tbl 11a

NOTE:

1. 'X' in part numbers indicates power rating (SA or LA).

AC Electrical Characteristics Over the Operating Temperature Supply Voltage Range⁽¹⁾

Symbol	Parameter	71321X35 71421X35 Com'l Only		71321X55 71421X55 Com'l & Ind		Unit
		Min.	Max.	Min.	Max.	
INTERRUPT TIMING						
tAS	Address Set-up Time	0	—	0	—	ns
tWR	Write Recovery Time	0	—	0	—	ns
tINS	Interrupt Set Time	—	25	—	45	ns
tNR	Interrupt Reset Time	—	25	—	45	ns

2691 tbl 11b

NOTE:

1. 'X' in part numbers indicates power rating (SA or LA).

Timing Waveform of Interrupt Mode⁽¹⁾

Set $\overline{\text{INT}}$

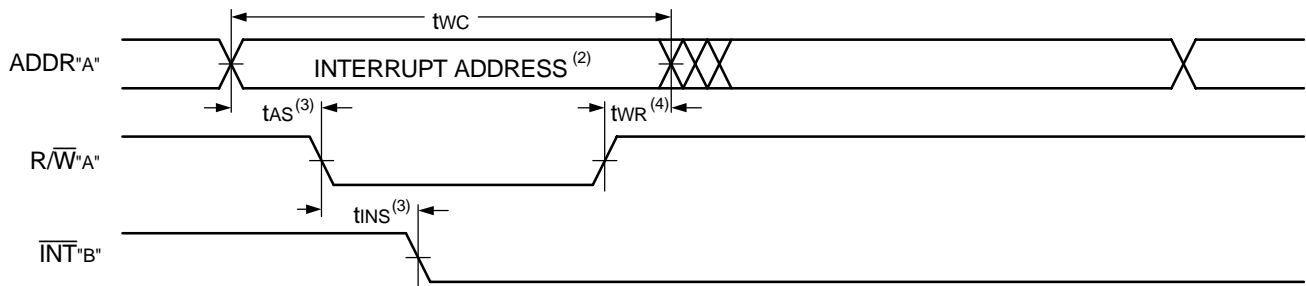

2691 drw 14

Clear $\overline{\text{INT}}$

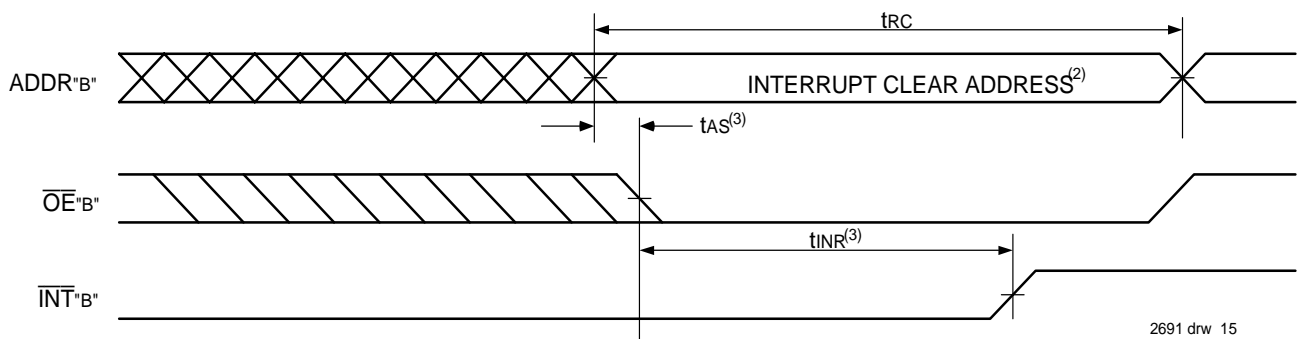

2691 drw 15

NOTES:

1. All timing is the same for left and right ports. Port "A" may be either left or right port. Port "B" is the opposite from port "A".
2. See Interrupt Truth Table.
3. Timing depends on which enable signal ($\overline{\text{CE}}$ or $\text{R}/\overline{\text{W}}$) is asserted last.
4. Timing depends on which enable signal ($\overline{\text{CE}}$ or $\text{R}/\overline{\text{W}}$) is de-asserted first.

Truth Tables

Truth Table I. Non-Contention Read/Write Control⁽⁴⁾

Left or Right Port ⁽¹⁾				Function
R/W	\overline{CE}	\overline{OE}	D ₀₋₇	
X	H	X	Z	Port Disabled and in Power-Down Mode, ISB ₂ or ISB ₄
X	H	X	Z	$\overline{CE}_R = \overline{CE}_L = V_{IH}$, Power-Down Mode, ISB ₁ or ISB ₃
L	L	X	DATA _{IN}	Data on Port Written Into Memory ⁽²⁾
H	L	L	DATA _{OUT}	Data in Memory Output on Port ⁽³⁾
H	L	H	Z	High Impedance Outputs

2691 tbl 12

NOTES:

1. $A_{0L} - A_{10L} \neq A_{0R} - A_{10R}$.
2. If $\overline{BUSY} = L$, data is not written.
3. If $\overline{BUSY} = L$, data may not be valid, see t_{WDD} and t_{DD} timing.
4. 'H' = V_{IH} , 'L' = V_{IL} , 'X' = DON'T CARE, 'Z' = HIGH IMPEDANCE

Truth Table II. Interrupt Flag^(1,4)

Left Port					Right Port					Function
R/WL	\overline{CE}_L	\overline{OE}_L	A _{10L} -A _{0L}	\overline{INT}_L	R/WR	\overline{CE}_R	\overline{OE}_R	A _{10R} -A _{0R}	\overline{INT}_R	
L	L	X	7FF	X	X	X	X	X	L ⁽²⁾	Set Right \overline{INT}_R Flag
X	X	X	X	X	X	L	L	7FF	H ⁽³⁾	Reset Right \overline{INT}_R Flag
X	X	X	X	L ⁽³⁾	L	L	X	7FE	X	Set Left \overline{INT}_L Flag
X	L	L	7FE	H ⁽²⁾	X	X	X	X	X	Reset Left \overline{INT}_L Flag

2691 tbl 13

NOTES:

1. Assumes $\overline{BUSY}_L = \overline{BUSY}_R = V_{IH}$
2. If $\overline{BUSY}_L = V_{IL}$, then No Change.
3. If $\overline{BUSY}_R = V_{IL}$, then No Change.
4. 'H' = HIGH, 'L' = LOW, 'X' = DON'T CARE

Truth Table III — Address \overline{BUSY} Arbitration

Inputs			Outputs		Function
\overline{CE}_L	\overline{CE}_R	A _{0L} -A _{10L} A _{0R} -A _{10R}	\overline{BUSY}_L ⁽¹⁾	\overline{BUSY}_R ⁽¹⁾	
X	X	NO MATCH	H	H	Normal
H	X	MATCH	H	H	Normal
X	H	MATCH	H	H	Normal
L	L	MATCH	(2)	(2)	Write Inhibit ⁽³⁾

2691 tbl 14

NOTES:

1. Pins \overline{BUSY}_L and \overline{BUSY}_R are both outputs for IDT71321 (Master). Both are inputs for IDT71421 (Slave). \overline{BUSY}_x outputs on the IDT71321 are open drain, not push-pull outputs. On slaves the \overline{BUSY}_x input internally inhibits writes.
2. 'L' if the inputs to the opposite port were stable prior to the address and enable inputs of this port. 'H' if the inputs to the opposite port became stable after the address and enable inputs of this port. If t_{APS} is not met, either \overline{BUSY}_L or $\overline{BUSY}_R = LOW$ will result. \overline{BUSY}_L and \overline{BUSY}_R outputs can not be LOW simultaneously.
3. Writes to the left port are internally ignored when \overline{BUSY}_L outputs are driving LOW regardless of actual logic level on the pin. Writes to the right port are internally ignored when \overline{BUSY}_R outputs are driving LOW regardless of actual logic level on the pin.

Ordering Information

XXXX	A	999	A	A	A	A		
Device Type	Power	Speed	Package		Process/ Temperature Range			
							Blank 8	Tube or Tray Tape and Reel
							Blank I ⁽¹⁾	Commercial (0°C to +70°C) Industrial (-40°C to +85°C)
							G ⁽²⁾	Green
							J	52-pin PLCC (J52)
							PF	64-pin TQFP (PN64)
							PP	52-pin STQFP (PP52)
							TF	64-pin STQFP (PP64)
							20	Commercial Only
							25	Commercial & Industrial
							35	Commercial Only
							55	Commercial & Industrial
							LA	Low Power
							SA	Standard Power
							71321	16K (2K x 8-Bit) MASTER Dual-Port SRAM w/ Interrupt
							71421	16K (2K x 8-Bit) SLAVE Dual-Port SRAM w/ Interrupt

Speed in nanoseconds

2691 drw 17 PP52

NOTES:

- Contact your sales office for industrial temperature range availability in other speeds, packages and powers.
- Green parts available. For specific speeds, packages and powers contact your local sales office.

LEAD FINISH (SnPb) parts are in EOL process. Product Discontinuation Notice - PDN# SP-17-02

Datasheet Document History

03/24/99:		Initiated datasheet document history Converted to new format Cosmetic typographical corrections
	Pages 2 and 3	Added additional notes to pin configurations
06/07/99:		Changed drawing format
11/10/99:		Replaced IDT logo
08/23/01:	Page 3	Increased storage temperature parameters Clarified TA parameter
	Page 4	DC Electrical parameters—changed wording from "open" to "disabled"
	Page 16	Fixed part numbers in "Width Expansion" paragraph Changed ±500mV to 0mV in notes
	Page 4	Industrial temperature range offering added to DC Electrical Characteristics for 25ns and removed for 35ns
	Page 7 and 9	Industrial temperature range added to AC Electrical Characteristics for 25ns
	Page 17	Industrial offering removed for 35ns ordering information
01/17/06:	Page 1	Added green availability to features
	Page 17	Added green indicator to ordering information
	Page 1 & 17	Replaced old IDT™ with new IDT™ logo

Datasheet Document History (continued)

08/25/06:	Page 14	Changed $\overline{\text{INT}}\text{"A"}$ to $\overline{\text{INT}}\text{"B"}$ in the CLEAR $\overline{\text{INT}}$ drawing in the Timing Waveform of Interrupt Mode
10/29/08:	Page 17	Removed "IDT" from orderable part number
09/10/12:	Page 1 & 2	52-pin STQFP added to the features and description
	Page 3	PP52-1 pin configuration added
	Page 9	Typo corrected
	Page 17	Added T&R indicator and PP52-1 package information to the ordering information
06/10/16:	Page 2	Changed diagram for the J52 pin configuration by rotating package pin labels and pin numbers 90 degrees clockwise to reflect pin 1 orientation and added pin 1 dot at pin 1 Removed J52 chamfers and aligned the top and bottom pin labels in the standard direction Changed diagram for the PN64/PP64 pin configuration by rotating package pin labels and pin numbers 90 degrees counter clockwise to reflect pin 1 orientation and added pin 1 dot at pin 1
	Page 3	PP52 pin configuration. Added the IDT logo, changed the text to be in alignment with new diagram marking specs Removed footnote 5 and its references
	Pages 2 & 17	In pin configuration footnotes and in the Ordering Information: The package codes J52-1, PN64-1, PP64-1 and PP52-1 changed to J52, PN64, PP64 & PP52 respectively to match standard package codes
02/20/18:		Product Discontinuation Notice - PDN# SP-17-02 Last time buy expires June 15, 2018



CORPORATE HEADQUARTERS
6024 Silver Creek Valley Road
San Jose, CA 95138

for SALES:
800-345-7015 or 408-284-8200
fax: 408-284-2775
www.idt.com

for Tech Support:
408-284-2794
DualPortHelp@idt.com

The IDT logo is a registered trademark of Integrated Device Technology, Inc.