



Power Your Critical Mission Today

VHR5-2800S SERIES

HIGH RELIABILITY COTS DC-DC CONVERTERS

Models Available

Input: 15 V to 50 V continuous, 80 V transient
 5 W, single output of 3.3 V, 5 V, 12 V, 15 V
 -40 °C to 100 °C Operation

DATASHEET

1.0 DESCRIPTION

The VHR series of industrial grade DC-DC converters provides cost effective, high reliability solutions for use in defense, avionics and manufacturing industries. The VHR industrial grade products leverage decades of VPT's proven heritage in military and aerospace electronics.

VPT's VHR5-2800S series is ideal for non flight-critical solutions in military, avionics, unmanned systems as well as manufacturing equipment and controls. A wide input voltage range which accommodates nominal 28 V inputs, low input and output ripple, fixed operating frequency and companion EMI filters simplify system design while ensuring operating success in the most rugged of environments.

These converters are designed and manufactured in a facility certified to ISO9001, J-STD-001 and IPC-A-610.

This product may incorporate one or more of the following U.S. patents:

- 5,784,266
- 5,790,389
- 5,963,438
- 5,999,433
- 6,005,780
- 6,084,792
- 6,118,673



1.1 FEATURES

- High Reliability at Low Cost
- 5 Watts Output Power
- Wide Input Voltage Range: 15 to 50 Volts per MIL-STD-704 and MIL-STD-1275
- High Input Transient Voltage: 80 Volts for 1 sec per MIL-STD-704A
- Input Undervoltage Lockout
- Fixed Frequency
- Output Soft Start
- Current Limit Protection
- Short Circuit Protection
- Magnetic Feedback, no Optoisolators
- Wide Temperature Range, -40 °C to 100 °C
- Internally Conformal Coated
- Standard Six Sided Non-Hermetic Rugged Metal Package

1.2 COMPLIANCE

- MIL-STD-1275
- MIL-STD-704
- Meets MIL-STD-461C-F and EN55022 when used with an appropriate VHR EMI Filter

1.3 PACKAGING

- Low-profile: 1.110" x 1.110" x 0.400"
- Max weight: 22 g

1.4 SIMILAR PRODUCTS AND ACCESSORIES

- [DVSA](#) 5 W single output DC-DC Converter
- [VXR7](#) 7 W single output COTS DC-DC Converter
- [VPT5](#) 5 W single output COTS DC-DC Converter
- [EMI filters, Thermal Pads, Front-End Modules and Accessories](#)

2.0 DESCRIPTION

2.1 BLOCK DIAGRAM

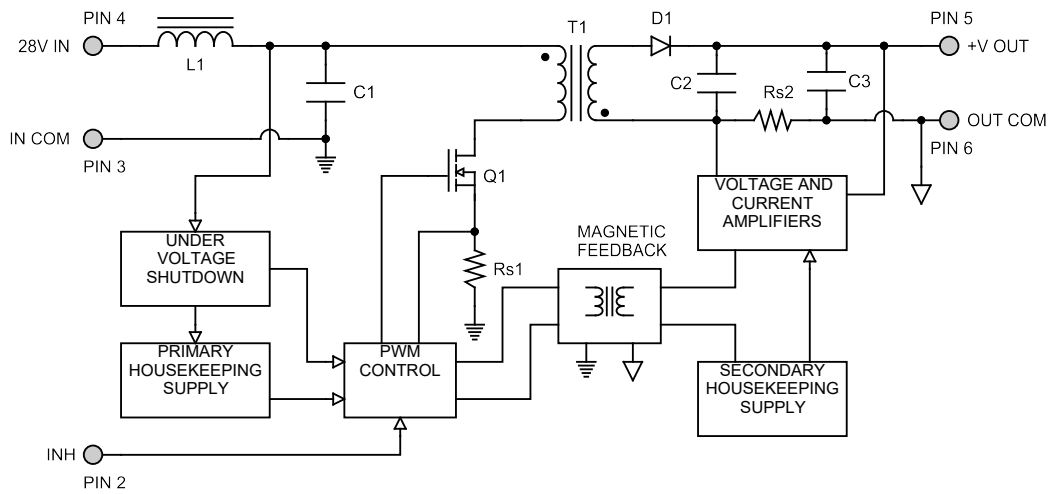

2.2 CONNECTION DIAGRAM

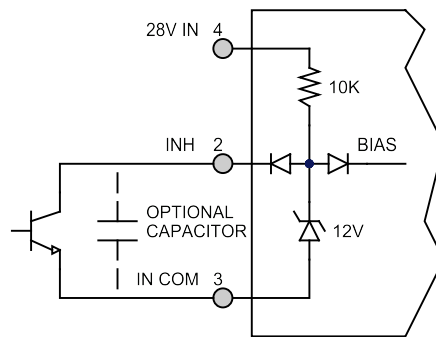
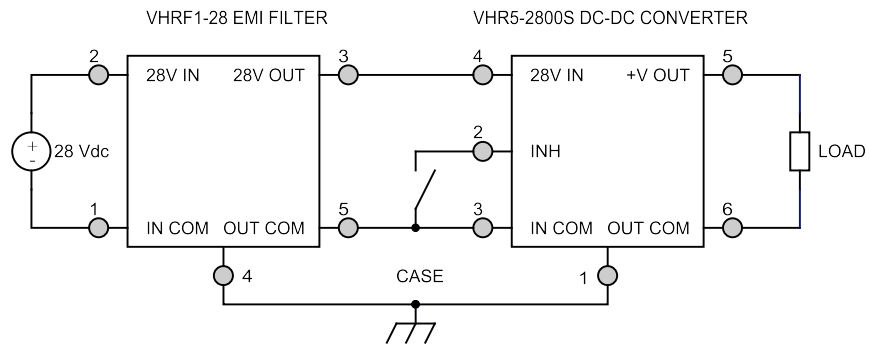

Inhibit Circuit (Shown with optional capacitor for turn-on delay)

3.0 SPECIFICATIONS

3.1 ABSOLUTE MAXIMUM RATINGS

Absolute Maximum Ratings

Input Voltage (Continuous):	50 V	Operating Temperature (Full Load):	-40 °C to 100 °C
Input Voltage (Transient, 1 second):	80 V	Storage Temperature:	-55 °C to 125 °C
		Lead Solder Temperature (10 seconds):	300 °C

3.2 PERFORMANCE SPECIFICATIONS

Tcase = -40 °C to 100 °C, Vin = +28 V ± 5%, Full Load, Unless Otherwise Specified

Parameter	Conditions	VHR5-283R3S			VHR5-2805S			Units
		Min	Typ	Max	Min	Typ	Max	
INPUT								
Voltage	Continuous	15	28	50	15	28	50	V
	Transient, 1 sec ³	-	-	80	-	-	80	V
Current	INH < 1.5 V	-	4	6	-	4	6	mA
	No Load	-	40	60	-	40	60	mA
Ripple Current	20 Hz to 10 MHz	-	30	50	-	30	50	mApp
Undervoltage Lockout	Turn On	12	-	14.8	12	-	14.8	V
	Turn Off ³	11	-	14.5	11	-	14.5	V
OUTPUT STATIC								
Voltage	Tcase = 25 °C	3.25	3.3	3.35	4.92	5	5.08	V
	Tcase = -40 °C to 100 °C	3.21	3.3	3.38	4.87	5	5.13	V
Power ²		0	-	5	0	-	5	W
Current ²		0	-	1.52	0	-	1	A
Ripple Voltage	20 Hz to 10 MHz	-	45	60	-	25	40	mVpp
Line Regulation	Vin = 15 V to 50 V	-	1	10	-	1	10	mV
Load Regulation	No Load to Full Load	-	1	10	-	1	10	mV
Load Fault Power Dissipation	Overload ³	-	-	3.7	-	-	3.3	W
	Short Circuit	-	-	3	-	-	3	W
OUTPUT DYNAMIC								
Load Step, Half to Full Load	Output Transient	-	150	250	-	100	300	mVpk
	Recovery ¹	-	400	600	-	300	500	µs
Line Step ³ , Vin = 16 V to 40 V	Output Transient	-	200	400	-	200	500	mVpk
	Recovery ¹	-	400	600	-	400	600	µs
Turn On, Vin = 0 to 28 V	Delay	-	10	20	-	10	20	ms
	Overshoot	-	0	15	-	0	25	mVpk
FUNCTION								
INH Pin Input ³	Output Inhibited	0	-	1.5	0	-	1.5	V
INH Pin Open Circuit Voltage ³	Output Enabled	9	11	13	9	11	13	V
GENERAL								
Efficiency		62	66	-	70	74	-	%
Capacitive Load ³		-	-	1000	-	-	1000	µF
Switching Frequency		425	500	550	425	500	550	kHz
Isolation	500 V DC, Tcase = 25 °C	100	-	-	100	-	-	MΩ
Weight		-	-	22	-	-	22	g
MTBF (MIL-HDBK-217F)	GM @ Tcase = 55 °C	-	468	-	-	468	-	kHr

1. Time for output voltage to settle within 1% of its nominal value

2. Derate linearly to 0 at 110 °C

3. Verified by qualification testing

3.2 PERFORMANCE SPECIFICATIONS (CONTINUED)

Tcase = -40 °C to 100 °C, Vin = +28 V ± 5%, Full Load, Unless Otherwise Specified

Parameter	Conditions	VHR5-2812S			VHR5-2815S			Units
		Min	Typ	Max	Min	Typ	Max	
INPUT								
Voltage	Continuous	15	28	50	15	28	50	V
	Transient, 1 sec ³	-	-	80	-	-	80	V
Current	INH < 1.5 V	-	4	6	-	4	6	mA
	No Load	-	40	60	-	40	60	mA
Ripple Current	20 Hz to 10 MHz	-	30	50	-	30	50	mApp
Undervoltage Lockout	Turn On	12	-	14.8	12	-	14.8	V
	Turn Off ³	11	-	14.5	11	-	14.5	V
OUTPUT STATIC								
Voltage	Tcase = 25 °C	11.82	12	12.18	14.77	15	15.23	V
	Tcase = -40 °C to 100 °C	11.7	12	12.3	14.62	15	15.38	V
Power ²		0	-	5	0	-	5	W
Current ²		0	-	0.42	0	-	0.33	A
Ripple Voltage	20 Hz to 10 MHz	-	15	30	-	15	30	mVpp
Line Regulation	Vin = 15 V to 50 V	-	1	10	-	1	10	mV
Load Regulation	No Load to Full Load	-	1	10	-	1	10	mV
Load Fault Power Dissipation	Overload ³	-	-	3	-	-	3	W
	Short Circuit	-	-	3	-	-	3	W
OUTPUT DYNAMIC								
Load Step, Half to Full Load	Output Transient	-	200	400	-	200	400	mVpk
	Recovery ¹	-	200	400	-	200	400	µs
Line Step ³ , Vin = 16 V to 40 V	Output Transient	-	450	700	-	450	700	mVpk
	Recovery ¹	-	300	500	-	300	500	µs
Turn On, Vin = 0 to 28 V	Delay	-	10	20	-	10	20	ms
	Overshoot	-	0	50	-	0	50	mVpk
FUNCTION								
INH Pin Input ³	Output Inhibited	0	-	1.5	0	-	1.5	V
INH Pin Open Circuit Voltage ³	Output Enabled	9	11	13	9	11	13	V
GENERAL								
Efficiency		71	75	-	71	76	-	%
Capacitive Load ³		-	-	500	-	-	500	µF
Switching Frequency		425	500	550	425	500	550	kHz
Isolation	500 VDC, Tcase = 25 °C	100	-	-	100	-	-	MΩ
Weight		-	-	22	-	-	22	g
MTBF (MIL-HDBK-217F)	GM @ Tcase = 55 °C	-	468	-	-	468	-	kHr

1. Time for output voltage to settle within 1% of its nominal value
2. Derate linearly to 0 at 110 °C
3. Verified by qualification testing

4.0 PERFORMANCE CURVES

T_{case} = 25 °C, Full Load, Unless Otherwise Specified

4.1 EFFICIENCY PERFORMANCE CURVES

4.1.1 VHR5-283R3S Efficiency (%) vs. Output Power (W)

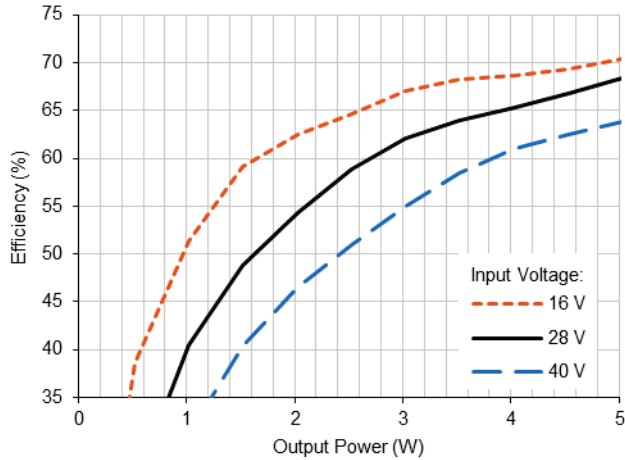

4.1.2 VHR5-2805S Efficiency (%) vs. Output Power (W)

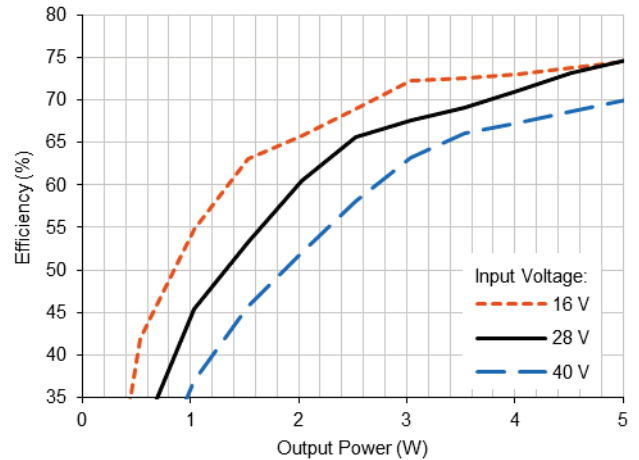

4.1.3 VHR5-2812S Efficiency (%) vs. Output Power (W)

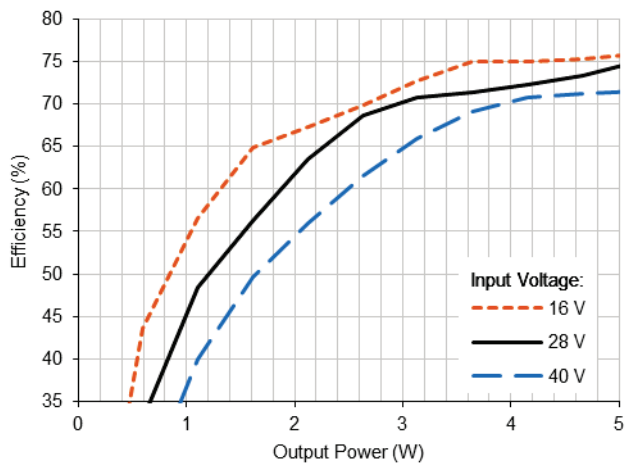

4.1.4 VHR5-2815S Efficiency (%) vs. Output Power (W)

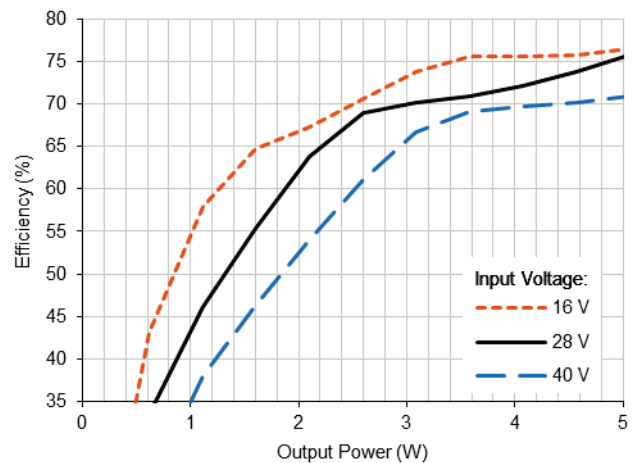

5.0 MECHANICAL OUTLINES AND PINOUT

Standard Package:

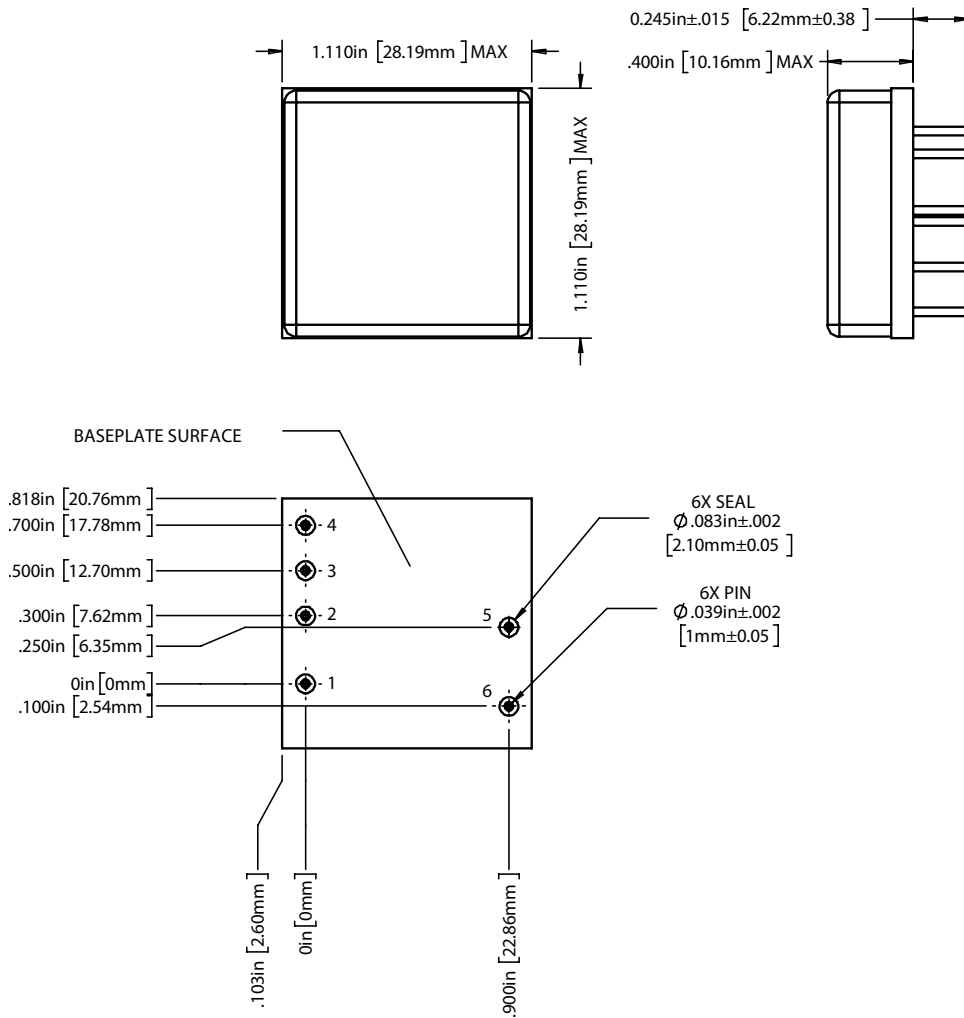

1. Case temperature is measured on the center of the baseplate surface.
2. Materials: Baseplate (Aluminum, conductive conversion coating); Cover (Nickel Plated); Pins (Copper, gold over nickel plating)
3. This Package is not hermetic. VPT offers a wide range of hermetic products. Please contact VPT for details if hermetic products are required.
4. For applications requiring exposure to liquid cleaning, please contact VPT.

Pin	Function	Pin	Function
1	CASE	4	28VIN
2	INHIBIT	5	+VOUT
3	INCOM	6	OUTCOM



6.0 PACKAGE PIN DESCRIPTION

Pin	Function	Description
1	CASE	Case Connection
2	INHIBIT	This is an open collector input. Logic Low = Disabled Output. Connect the inhibit pin to input common to disable the output. Unconnected, open collector or open drain = Enabled Output.
3	INCOM	Input Return Connection
4	28VIN	Positive Input Voltage Connection
5	+VOUT	Positive Output Voltage Connection
6	OUTCOM	Output Return Connection

7.0 ENVIRONMENTAL SCREENING

Screening	Condition
Internal Visual	IPC-A-610, Class 3
Final Electrical	100% at 25 °C
External Visual	Internal Procedure

8.0 ORDERING INFORMATION

VHR5-	28	05	S
1	2	3	4

(1) Product Series	(2) Nominal Input Voltage	(3) Output Voltage	(4) Number of Outputs
VHR5-	28 28 Volts	3R3 3.3 Volts 05 5 Volts 12 12 Volts 15 15 Volts	S Single

Please contact your sales representative or the VPT Inc. Sales Department for more information concerning additional environmental screening and testing, different input voltage, output voltage, power requirements, and source inspection.

9.0 CONTACT INFORMATION

To request a quotation or place orders please contact your sales representative or the VPT, Inc. Sales Department at:

Phone: (425) 353-3010
 Fax: (425) 353-4030
 E-mail: vptsales@vptpower.com

All information contained in this datasheet is believed to be accurate, however, no responsibility is assumed for possible errors or omissions. The products or specifications contained herein are subject to change without notice. VPT, its logo and tagline are registered trademarks in the U.S. Patent and Trademark Office.

10.0 ADDITIONAL INFORMATION

Visit the [VPT website](http://www.vptpower.com) for additional technical resources, including:

[Product Literature](#)



[Application Notes and White Papers](#)

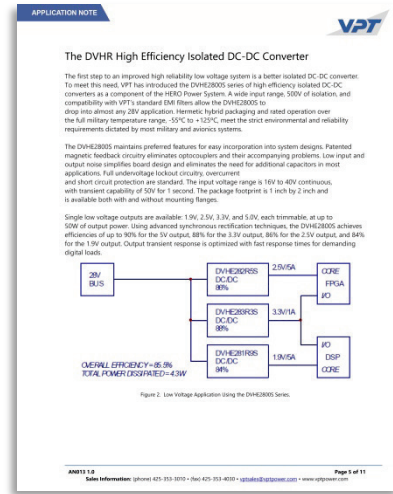

[Technical Video Labs](#)



[Additional Products For Avionics/Military, Hi-Temp, Hi-Rel COTS, and Space Applications](#)

