

## ASA306B Data Sheet

*50 ~ 1200 MHz Gain Adjustable Trans-impedance Amplifier MMIC*

### 1. Product Overview

#### 1.1 General Description

ASA306B, a trans-impedance amplifier (TIA) with voltage controlled attenuator, has a high linearity and low noise over a wide range of frequency up to 1.2 GHz, being suitable for use in the FTTH, optical receiver, distribution amplifiers, and drop-in amplifiers of CATV systems. The amplifier is available in a QFN24 plastic encapsulated package and passes through the stringent DC, RF, and reliability tests.

#### 1.2 Features

- Operating Frequency at 50 ~ 1200 MHz
- Optical Input from -7 dBm to +1 dBm
- EIN: 3.1 pA/rtHz
- Trans-impedance Gain Adjustable from 38 dB to 18 dB @  $V_{ctrl} = 0.0 \sim 4.3$  V (adjustable)
- Gain Flatness:  $\pm 1.2$  dB over  $V_{ctrl} = 0.0 \sim 4.3$  V and 50 ~ 1200 MHz
- Output Power: 86 dB $\mu$ V @ NTSC 79 channels
- Single +5 V, 290 mA

#### 1.3 Applications

- FTTH
- Optical Receiver
- Distribution Amplifier
- Drop-in Amplifier

#### 1.4 Package Profile & RoHS Compliance

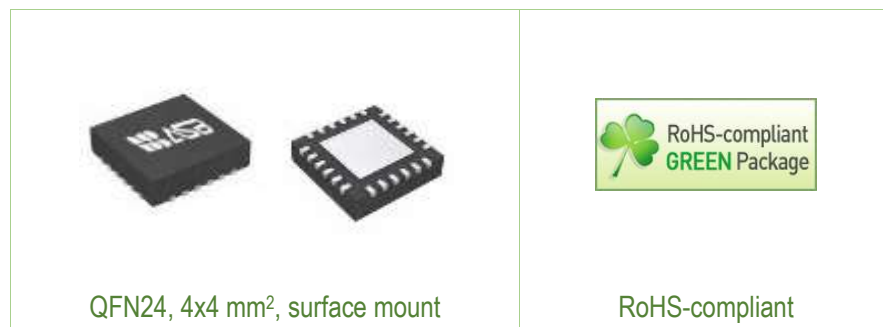

## 2. Summary on Product Performances

### 2.1 Typical Performance

Supply voltage = +5 V,  $T_A = +25\text{ }^\circ\text{C}$ ,  $Z_0 = 75\ \Omega$ .

Parameters	Test Conditions	Min	Typ	Max	Units
Frequency		50		1200	MHz
Gain (W/O Atten)	541.25 MHz, $V_{ctrl} = 0.0\text{ V}$		38		dB
Gain Adjustable Range	Over $V_{ctrl} = 0.0 \sim 4.3\text{ V}^{1)}$		20		dB
Gain Flatness	50 ~ 1200 MHz, over $V_{ctrl} = 0.0 \sim 4.3\text{ V}$		$\pm 1.2$		dB
Output Return Loss	50 ~ 1200 MHz, over $V_{ctrl} = 0.0 \sim 4.3\text{ V}$			-15	dB
EIN	50 ~ 1200 MHz, $V_{ctrl} = 0.0\text{ V}$		3.1		pA/rHz
CN	541.25 MHz, Optical input -5 dBm		48		dBc
CSO <sup>2)</sup>		57			dBc
CTB <sup>2)</sup>		53			dBc
XMOD <sup>2)</sup>		55			
Current Consumption	$V_{device} = +5\text{ V}$		290	330	mA

1)  $V_{ctrl}$  can be adjusted by R21, R22, and R23 in the application circuit.

2) OMI = 3.5 %, for  $P_{out} = 86\text{ dB}\mu\text{V}$ , 541.25 MHz of NTSC 79 channels in the optical input range of -7 ~ +1 dBm.

### 2.2 Product Specification

Supply voltage = +5 V,  $T_A = +25\text{ }^\circ\text{C}$ ,  $Z_0 = 75\ \Omega$ .

Parameter	Min	Typ	Max	Unit
Frequency		541.25		MHz
Gain		38		dB
Output Return Loss		-15		dB
Current Consumption		290		mA

### 2.3 Application Block Diagram

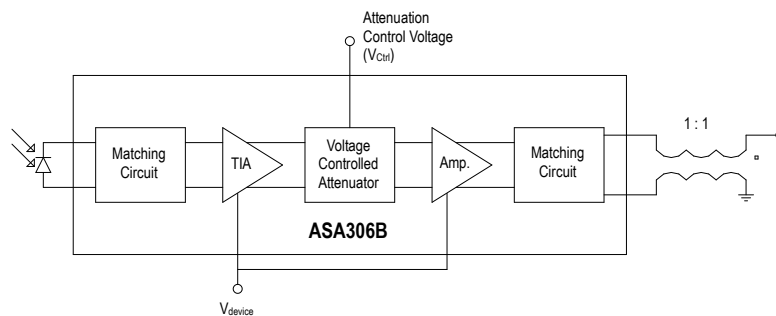

## 2.4 Absolute Maximum Ratings

Parameters	Max. Ratings
Operation Case Temperature	-40 to +85 °C
Storage Temperature	-40 to +150 °C
Device Voltage	+8 V
Operation Junction Temperature	+160 °C
Input RF Power (CW)	+26 dBm
Maximum Current	500 mA

## 2.5 Thermal Resistance

Symbol	Description	Typ	Unit
$R_{th}$	Thermal resistance from junction to lead	18	°C/W

## 2.6 Pin Descriptions

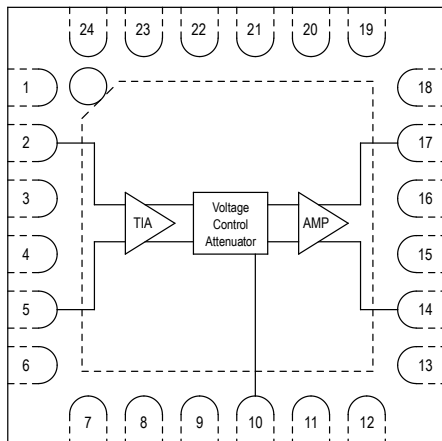

(NOTE)

The left schematic is the top view of QFN24 plastic package with a circled pin 1 mark and a dotted lead & metal exposed paddle on its bottom.

Pin	Pin Name	Description	Pin	Pin Name	Description
1	NC	No connection	14	AMP OUT B	AMP output B
2	TIA IN A	TIA input A	15	AMP I <sub>ADJ2</sub>	AMP B current adjust
3	TIA I <sub>ADJ1</sub>	TIA A current adjust	16	AMP I <sub>ADJ1</sub>	AMP A current adjust
4	TIA I <sub>ADJ2</sub>	TIA B current adjust	17	AMP OUT A	AMP output A
5	TIA IN B	TIA input B	18	NC	No connection
6	NC	No connection	19	AMP IN A	AMP input A
7	TIA OUT B	TIA output B	20	VCA OUT B	VCA output B
8	VCA IN B	VCA input B	21	NC	No connection
9	NC	No connection	22	NC	No connection
10	V <sub>ctrl</sub>	Gain control voltage	23	VCA IN A	VCA input A
11	VCA OUT B	VCA output B	24	TIA OUT A	TIA output A
12	AMP IN B	AMP input B	25	Paddle	RF & DC Ground
13	NC	No connection			

## 3. Application: 50 ~ 1200 MHz

### 3.1 Application Circuit & Evaluation Board

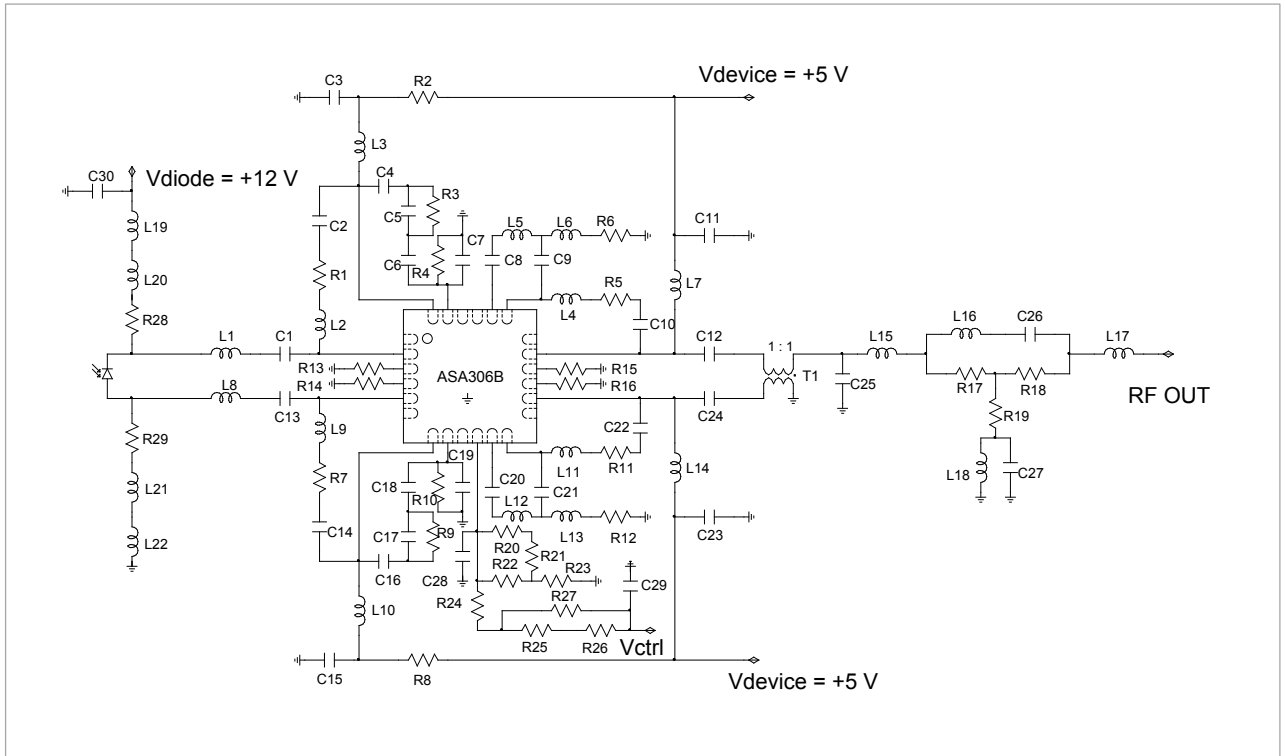

\* Note: C28 must be placed to Pin10(Vctrl) as close as possible.

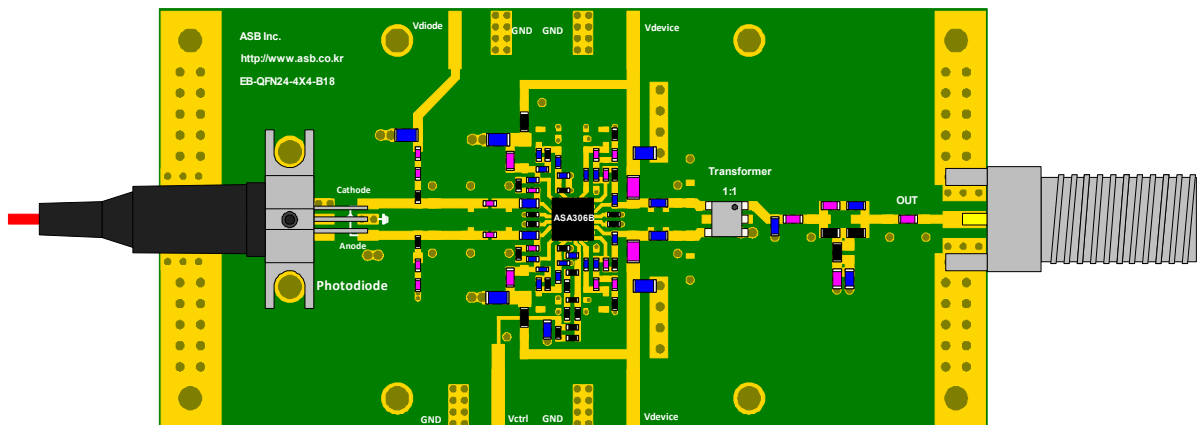

[PCB Gerber and DXF File can be downloaded.](#)

## Bill of Material, $V_{ctrl} = 0.0 \sim 4.3 V^{1)}$ (adjustable)

Symbol	Size	Value	Manufacturer	Symbol	Size	Value	Manufacturer
ASA306B	-	-	ASB	R19	1608	62 $\Omega$	SAMSUNG
C5, C17	1005	3.3 pF	MURATA	R23 <sup>1)</sup>	1005	2.2 k $\Omega$	SAMSUNG
C2, C4, C6, C8, C9, C10, C14, C16, C18, C20, C21, C22, C28	1005	1 $\mu$ F	MURATA	R22 <sup>1)</sup> , R27	1005	3 k $\Omega$	SAMSUNG
C1, C12, C13, C24, C29	1608	1 $\mu$ F	MURATA	R21 <sup>1)</sup>	1005	750 $\Omega$	SAMSUNG
C7, C19	1005	0.75 pF	MURATA	R24	1005	7.8 k $\Omega$	SAMSUNG
C26	1608	1.5 pF	MURATA	R20 <sup>2)</sup> , R25 <sup>2)</sup>	1005	3.3 k $\Omega$	MURATA
C27	1608	0.5 pF	MURATA	L5, L12	1005	2.7 nH	MURATA
C25	1608	1 pF	MURATA	L18	1608	27nH	MURATA
C3, C11, C15, C23, C30	2012	10 $\mu$ F	MURATA	L1, L8	1005	5.6 nH	MURATA
R2, R8	1608	0 $\Omega$	SAMSUNG	L4, L11	1005	15 nH	MURATA
R3, R9	1005	33 $\Omega$	SAMSUNG	L2, L9	1005	39 nH	MURATA
R13, R14	1005	82 $\Omega$	SAMSUNG	L3, L10	1608	680 nH	SAMSUNG
R6, R12, R15, R16	1005	200 $\Omega$	SAMSUNG	L7, L14	3216	1 $\mu$ H	MURATA
R4, R10	1005	100 $\Omega$	SAMSUNG	L6, L13	1005	47 nH	MURATA
R26	1005	0 $\Omega$	SAMSUNG	L16	1608	12 nH	MURATA
R28, R29	1005	1 k $\Omega$	SAMSUNG	L15, L17	1608	4.7 nH	MURATA
R1, R5, R7, R11	1005	1.2 k $\Omega$	SAMSUNG	L19 <sup>3)</sup> , L20 <sup>3)</sup> , L21 <sup>3)</sup> , L22 <sup>3)</sup>	1005	Ferrite Bead	MURATA
R17, R18	1608	18 $\Omega$	SAMSUNG	T1 <sup>4)</sup>	SM-164	1 : 1	MACOM

1)  $V_{ctrl}$  adjusting resistors. ex) For  $V_{ctrl} = 0.0 \sim 3.3 V$ , R21 = 390  $\Omega$ , R22 = 4.3 k $\Omega$ , and R23 = 3.9 k $\Omega$ .

2) NCP15XQ332J03RC

3) BLM15HD182SN

4) MABACT0040

*(Intentionally Blanked)*

### 3.2 Plots of Performances, $V_{ctrl} = 0.0 \sim 4.3 \text{ V}$

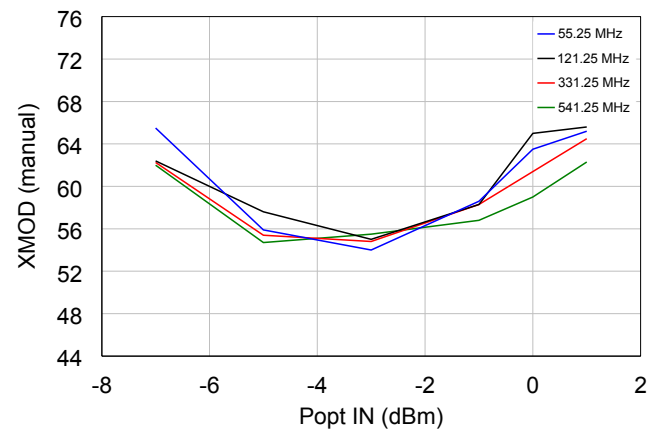
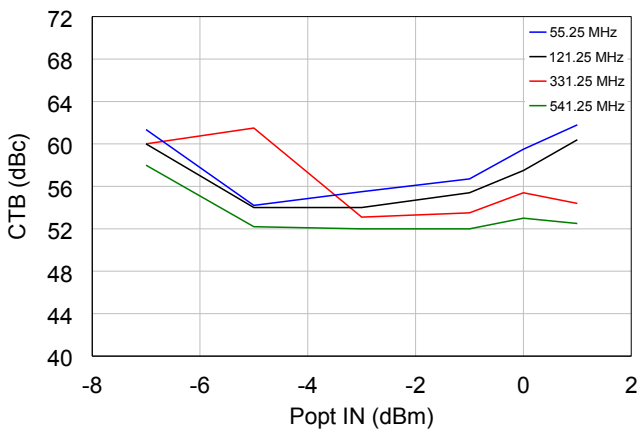
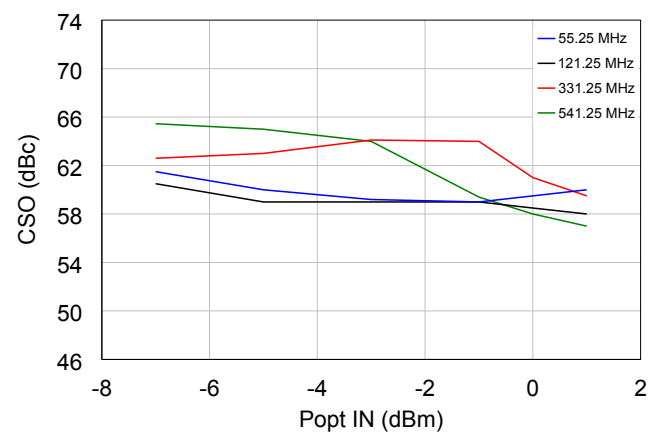
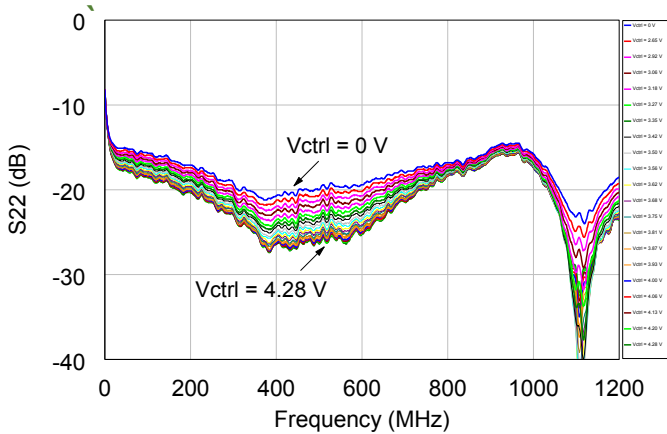
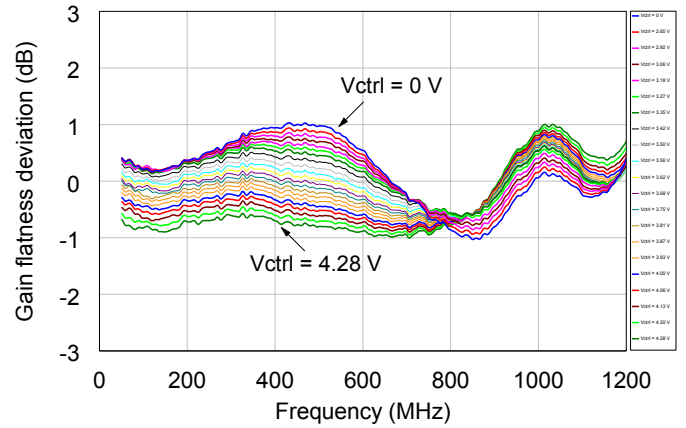
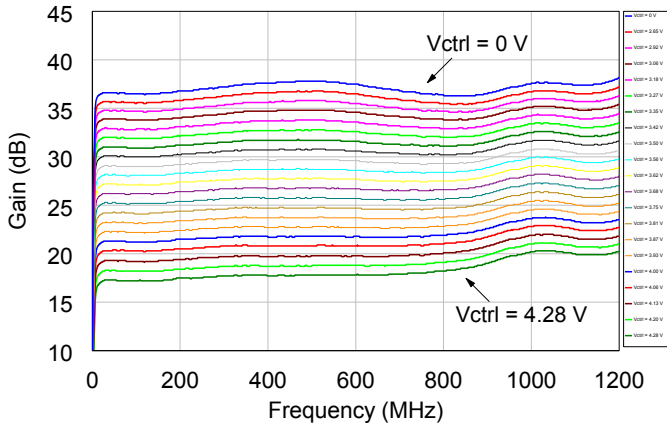

## 3.3 Plots of Performances with Temperature, $V_{ctrl} = 0.0 \sim 4.3$ V

Gain Flatness Deviation @ -40 °C

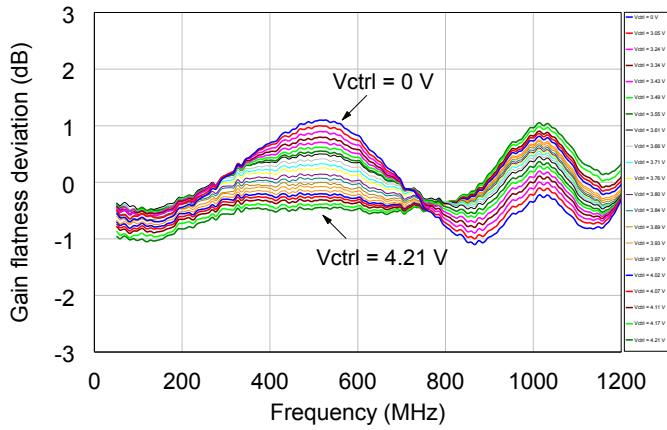

Gain Flatness Deviation @ 85 °C

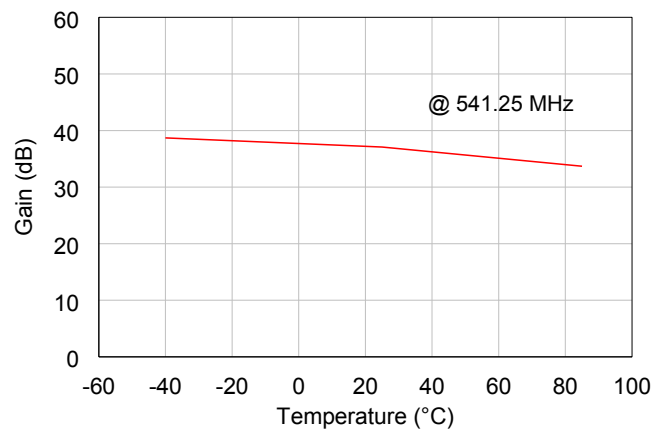
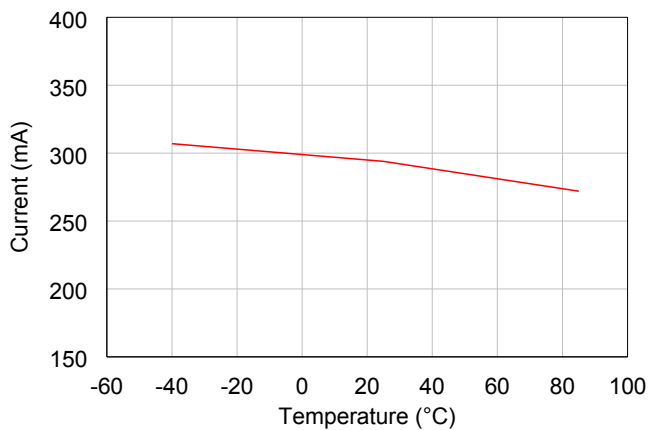
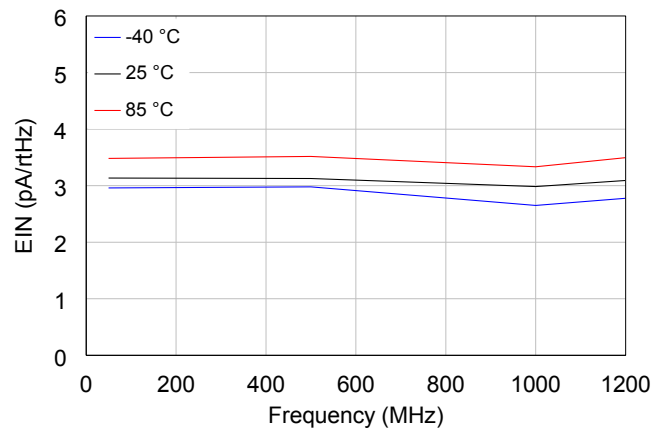
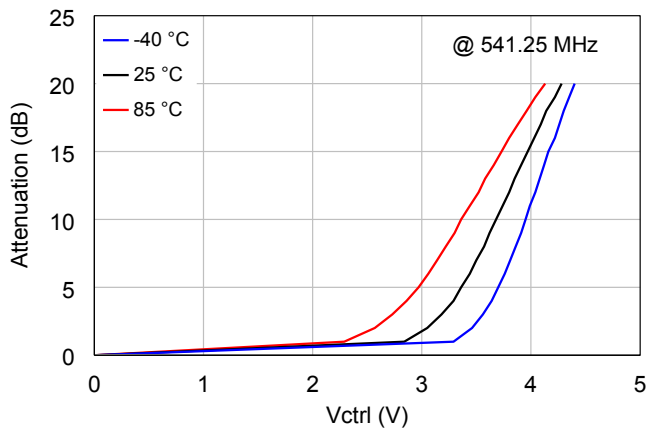
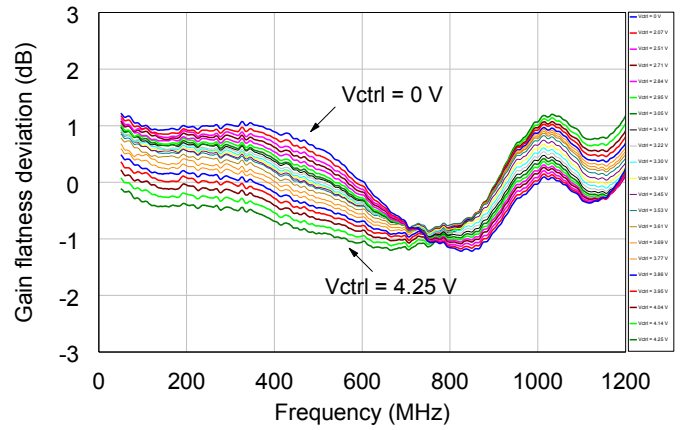

## 4. Package Outline (QFN24, 4.0x4.0x1.5 mm<sup>3</sup>)

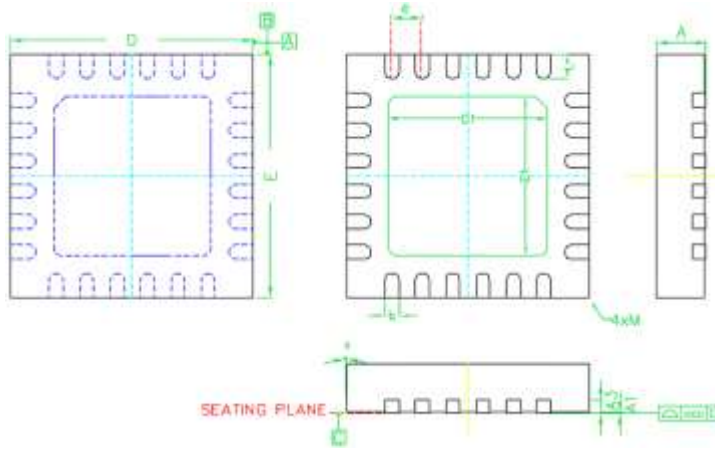

Symbols	Dimensions (In mm)		
	MIN	NOM	MAX
A	0.80	0.85	0.90
A1	0	0.010	0.030
A3	---	0.20REF	---
b	0.18	0.23	0.28
D	3.95	4.00	4.03
D1	---	2.60BSC	---
E	3.95	4.00	4.03
E1	---	2.60BSC	---
e	---	0.50BSC	---
L	0.35	0.40	0.45
θ	-12	---	0
ccc	---	0.08	---
M	---	---	0.05
Burr	0	0.030	0.060

## 5. Surface Mount Recommendation (In mm)

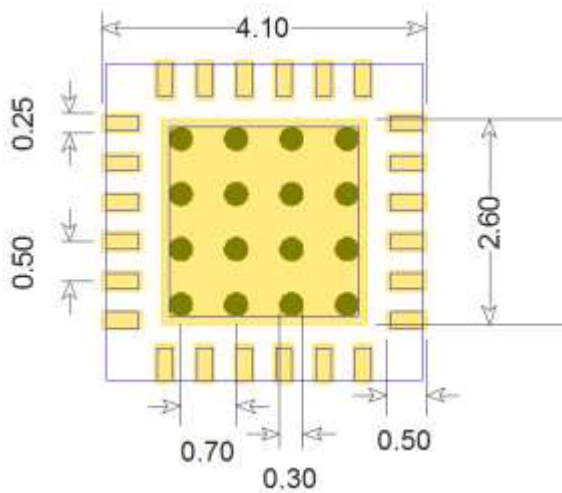

### NOTE

1. The number and size of ground via holes in a circuit board is critical for thermal and RF grounding considerations.
2. Recommended is that the ground via holes be placed on the bottom of the exposed pad of the device for better RF and thermal performance, as shown in the drawing at the left side.

## 6. ESD Classification & Moisture Sensitivity Level

### ESD Classification

HBM	Class 1B	Voltage Level: 750 V
-----	----------	----------------------

CAUTION: Gallium Arsenide Integrated Circuits are sensitive to electrostatic discharge (ESD) and can be damaged by static electricity. Proper ESD control techniques should be used when handling these devices.

### Moisture Sensitivity Level

MSL 3 at 260 °C reflow
------------------------

## 7. Recommended Soldering Reflow Profile

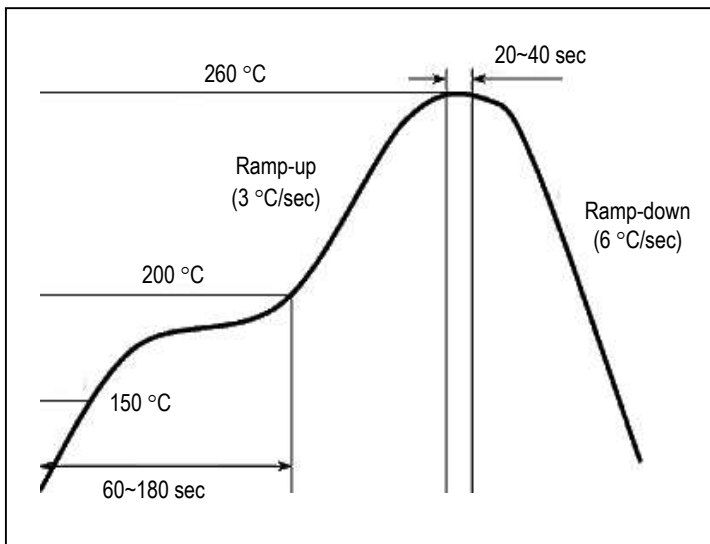

(End of Datasheet)