

### 1. Mechanical Dimensions:

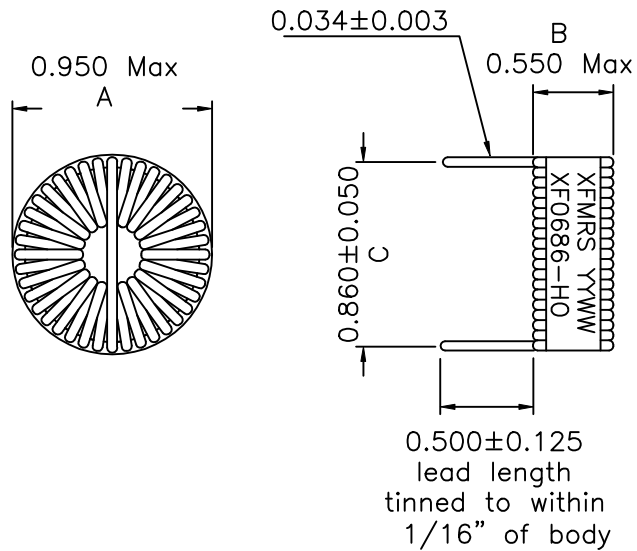

### 2. Schematic:

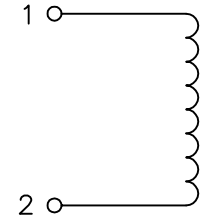

### 3. Electrical Specifications:

Inductance: 68.0uH ±15% @10KHz, 0.1V

Inductance: 45.7uH Typ @10KHz, 0.1V with 4.9Adc

DC Resistance: 0.046 Ohms Max

#### Note:

1. Solderability: Leads shall meet MIL-STD-202, Method 208D for solderability.
2. Flammability: UL94V-0,
3. ASTM oxygen index: > 28% ,
4. Temperature rating: 155°C. UL file E151556,
5. Operating Temperature Range: -30°C to +130°C

Doc Rev: A/1

XFMR5 Inc.	Title: Inductor			
	UNLESS OTHERWISE SPECIFIED	P/N: XF0686-HO		REV. A
TOLERANCES:	DWN.	李小锋	Dec-14-01	
.xx ±0.01	CHK.	廖玉坤	Dec-14-01	
Dimensions in Inch	APP.	BW	Dec-14-01	
SHEET 1 OF 1				