



LIGITEK ELECTRONICS CO.,LTD.
Property of Ligitek Only

SURFACE MOUNT LED TAPE AND REEL



Lead-Free Parts

LG-3228WK-T-A02

DATA SHEET

DOC. NO : QW0905-LG-3228WK-T-A02

REV. : A

DATE : 19 - Oct. - 2017



Features:

1. Top view white LED.
2. Leadframe package with individual 4 pin.
3. Wide viewing angle.
4. Feature of the device:more light due to higher optical efficiency;extremely wide viewing angle;ideal for backlighting and coupling in light guide.
5. High Luminous Intensity.
6. High Efficiency.

Descriptions:

The LG-3228 has wide viewing angle and optimized light coupling by inter reflector,The low current requirement makes this device ideal for portable equipment or any other application where power is at a premium.

Applications:

1. LCD back light.
2. Mobile phones.
3. Indicators.
4. Switch lights.
5. Lighting.

Device Selection Guide:

PART NO	MATERIAL	COLOR	
		Emitted	Lens
LG-3228WK-T-A02	InGaN	White	Yellow Diffused

Package Dimensions

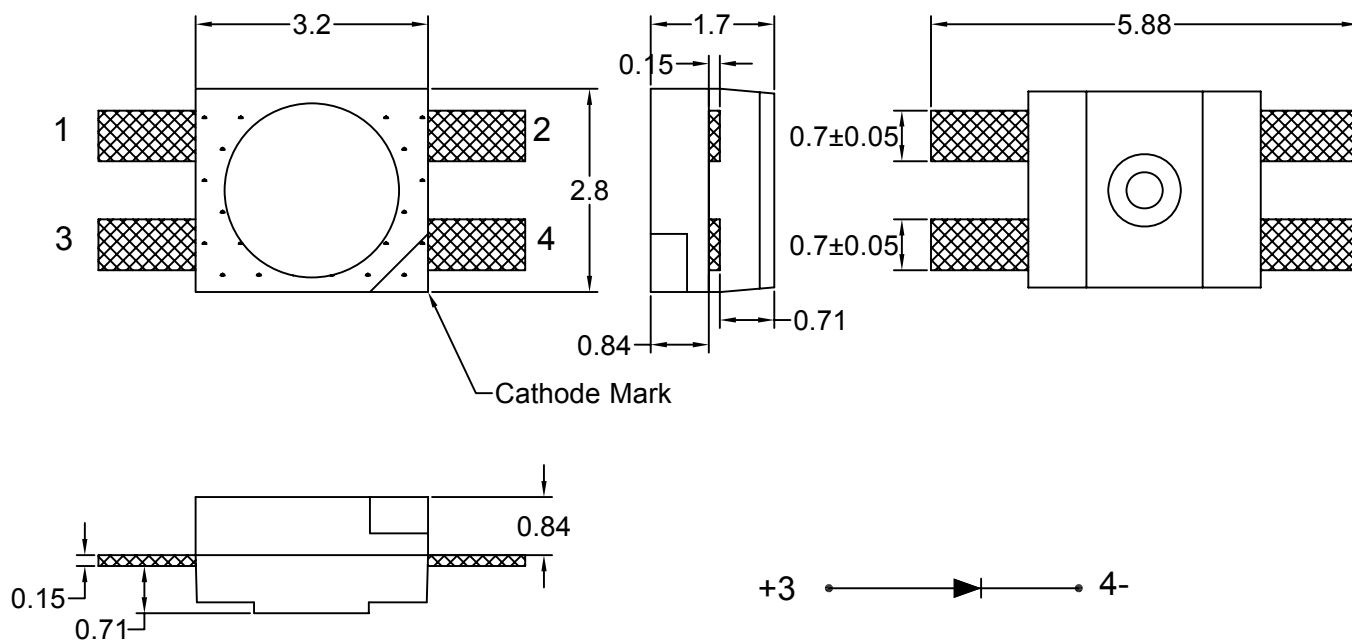

Note : 1.All dimension are in millimeter tolerance is $\pm 0.2\text{mm}$ unless otherwise noted.
2.Specifications are subject to change without notice.

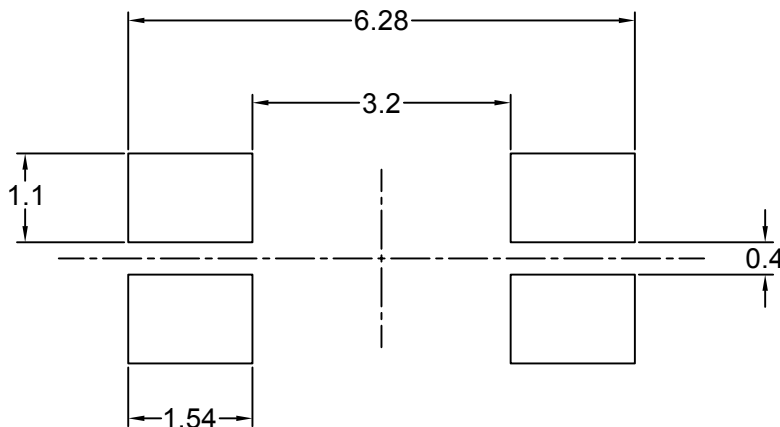

Note : The tolerances unless mentioned is $\pm 0.1\text{mm}$, Angle ± 0.5 . Unit=mm.

Absolute Maximum Ratings at Ta=25°C

Parameter	Symbol	Ratings	UNIT
Forward Current	IF	30	mA
Peak Forward Current Duty 1/10@10KHz	IFP	100	mA
Power Dissipation	PD	96	mW
Reverse Current @5V	Ir	50	μA
Electrostatic Discharge	ESD	500	V
Operating Temperature	Topr	- 40 ~ + 85	°C
Storage Temperature	Tstg	- 40 ~ + 100	°C

Typical Electrical & Optical Characteristics (Ta=25°C)

Items	Symbol	Min.	Typ.	Max.	UNIT	CONDITION
Luminous Intensity	Iv	500	600	900	mcd	IF=5mA
Chromaticity Coordinates	X	0.26	----	0.29	----	IF=5mA
	Y	0.255	----	0.31	----	IF=5mA
Forward Voltage	V _F	2.6	----	3.2	V	IF=5mA
Viewing Angle	2θ 1/2	----	120	----	deg	IF=5mA

Note : 1.The forward voltage data did not including ±0.1V testing tolerance.
 2.The luminous intensity data did not including ±15% testing tolerance.
 3.The color coordinates measurement allowance is ±0.01 testing tolerance

Luminous Intensity Classification

BIN CODE	Iv(mcd) at5mA	
	Min.	Max.
U21U22	500	600
U23U24	600	700
U25U26	700	800
V11V12	800	900

Forward Voltage Classification

BIN CODE	Vf(v) at5mA	
	Min.	Max.
1	2.6	2.7
2	2.7	2.8
3	2.8	2.9
4	2.9	3
5	3	3.1
6	3.1	3.2

Chromaticity Coordinates Specifications For Bin Grading

Color Coordiante at 5mA								
BIN CODE	1		2		3		4	
	X	Y	X	Y	X	Y	X	Y
B1	0.26	0.265	0.26	0.225	0.27	0.24	0.27	0.28
B2	0.27	0.28	0.27	0.24	0.28	0.255	0.28	0.295
B3	0.28	0.295	0.28	0.255	0.29	0.27	0.29	0.31

CIE Chromaticity Diagram

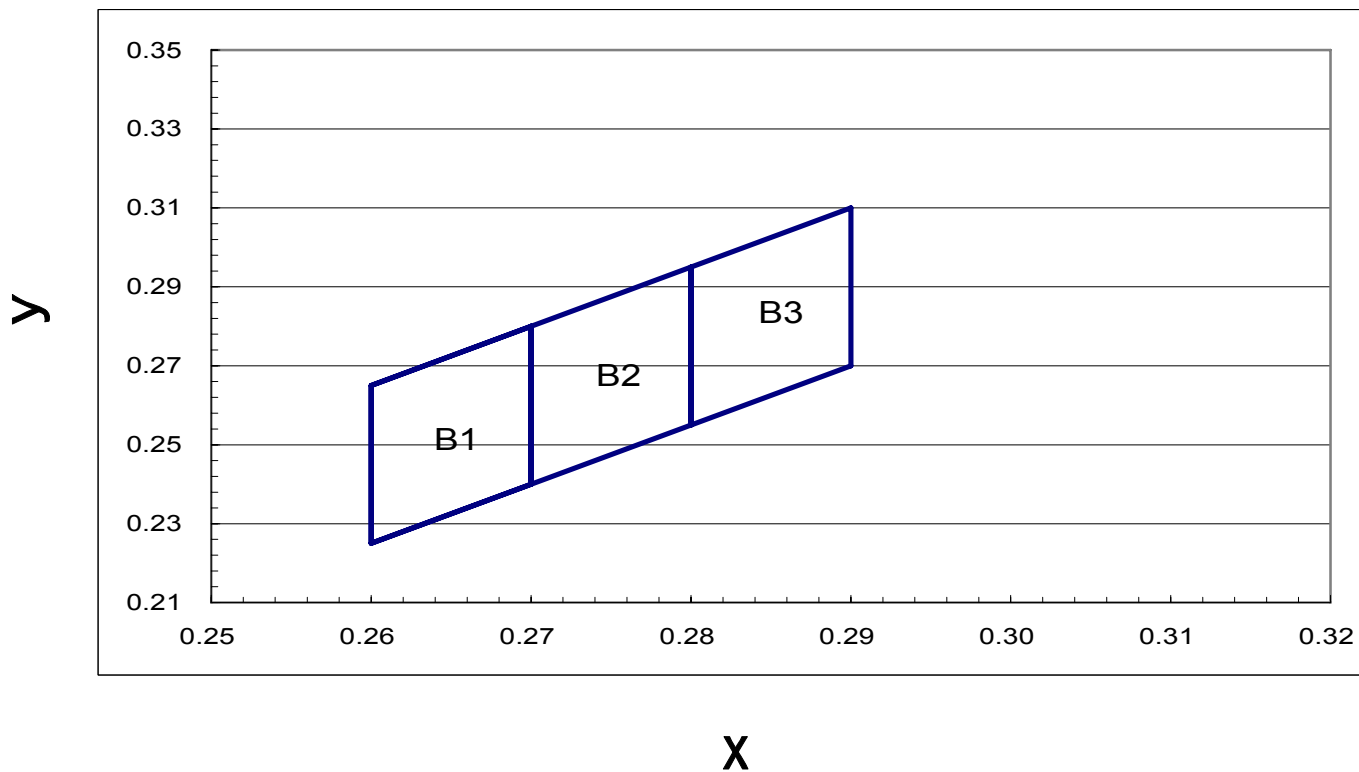

Typical Electro-Optical Characteristics Curve

WK CHIP

Fig.1 Forward current vs. Forward Voltage

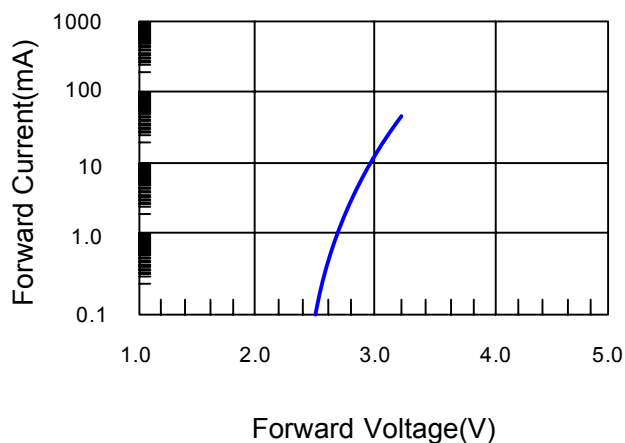

Fig.2 Relative Intensity vs. Forward Current

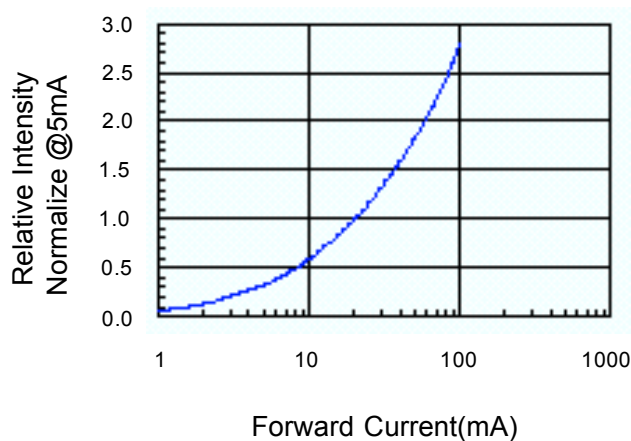

Fig.3 Forward Voltage vs. Temperature

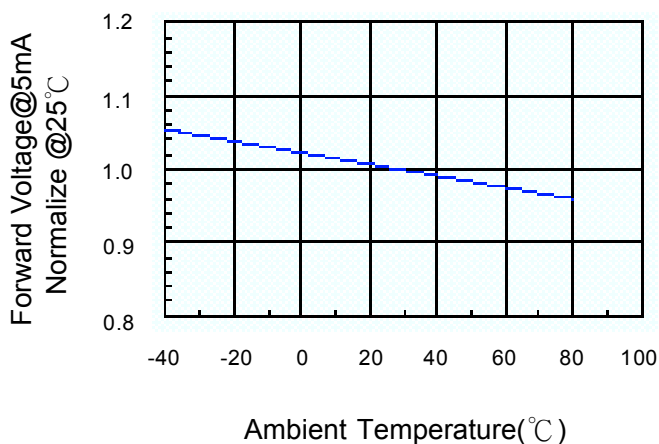

Fig.4 Relative Intensity vs. Temperature

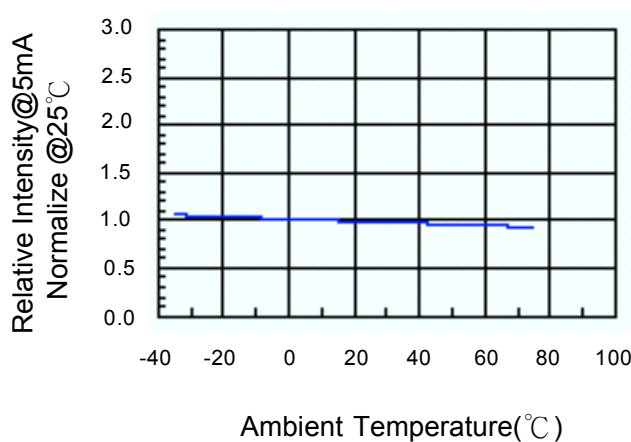

Fig.5 Luminous Spectrum (Ta=25°C)

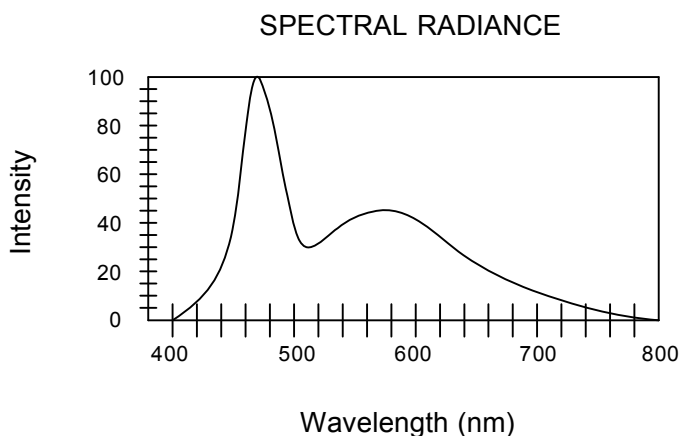
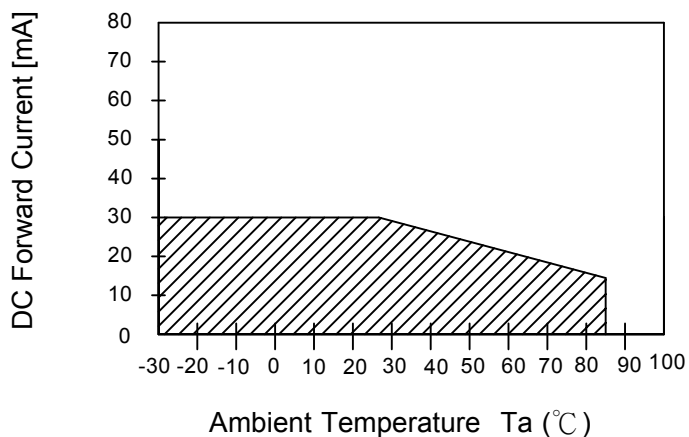
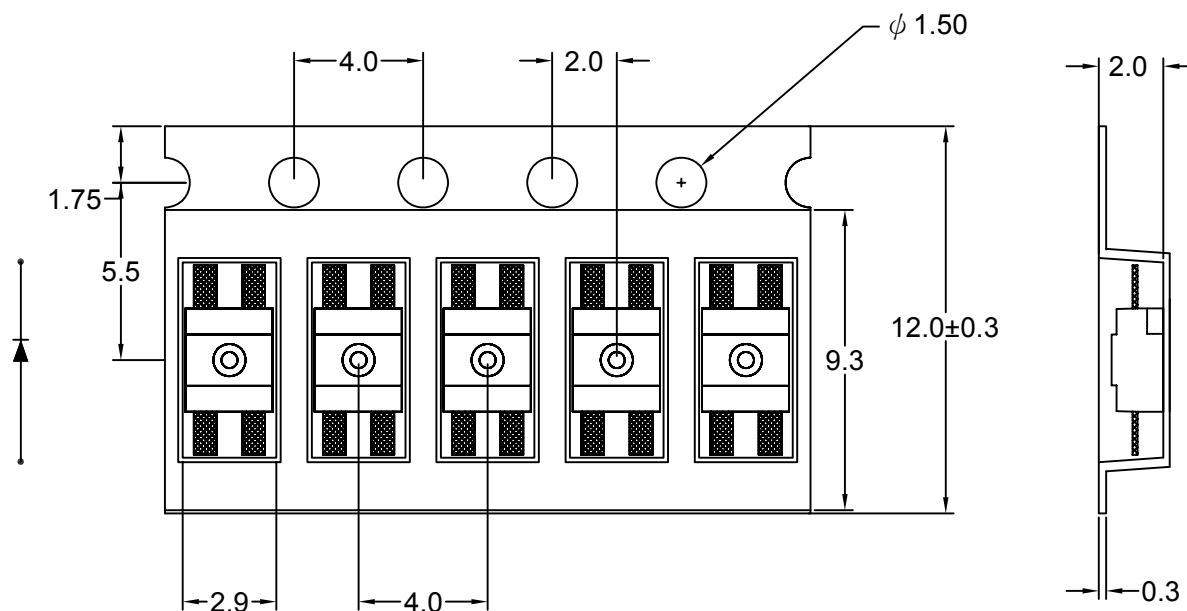

Fig.6 Forward Current vs. Temperature



Carrier Tape Dimensions







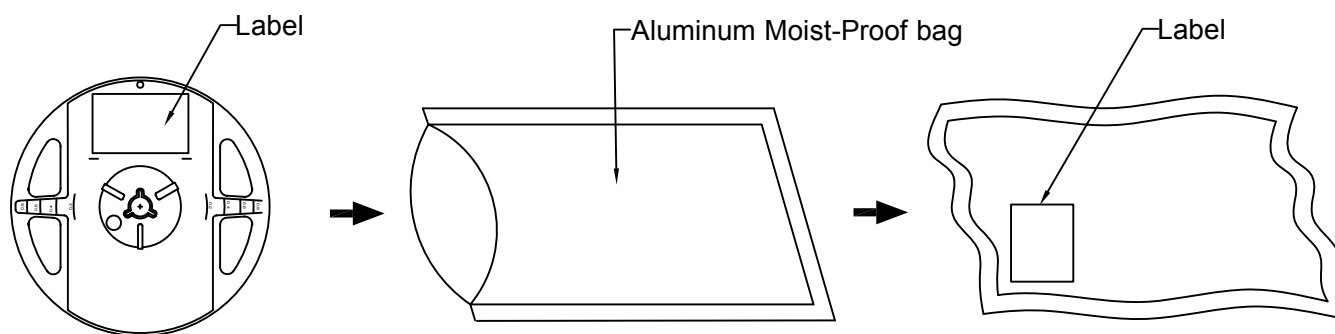

Note : The tolerances unless mentioned is ± 0.1 mm, Angle ± 0.5 . Unit=mm.

• Packing Specifications



Part No.	Description	Quantity/Reel
LG-3228WK-T-A02	12mm tape, 7" reel	2000 PCS

Label Explanation

	LIGITEK ELECTRONICS CO., LTD.	
PART :		LG-3228WK-T-A02
LOT :		GS11610168
QTY(PCS):		2000
BIN/HUE :		U23U24/B2
		VF:2.7-2.8

BIN : Luminous Intensity

HUE : Dominant Wavelength

VF : Forward Voltage

Reel Dimensions

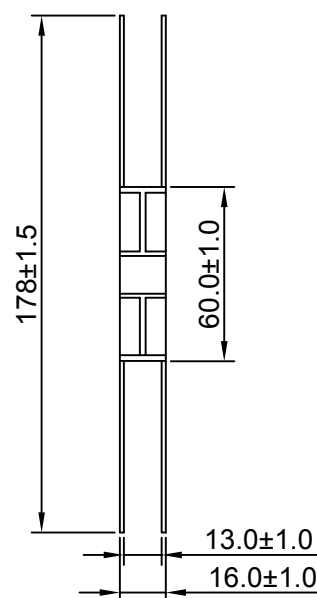
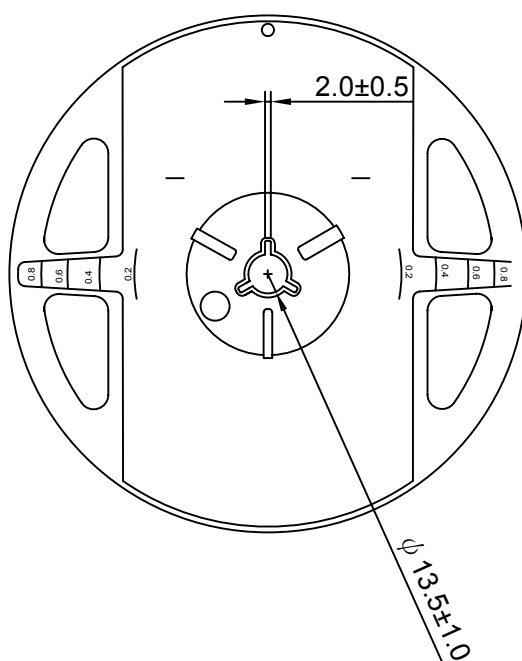

Box Explanation

1. 4 BAG / INNER BOX
2. INNER BOX SIZE : L X W X H 23cm X 8.5cm x 26cm

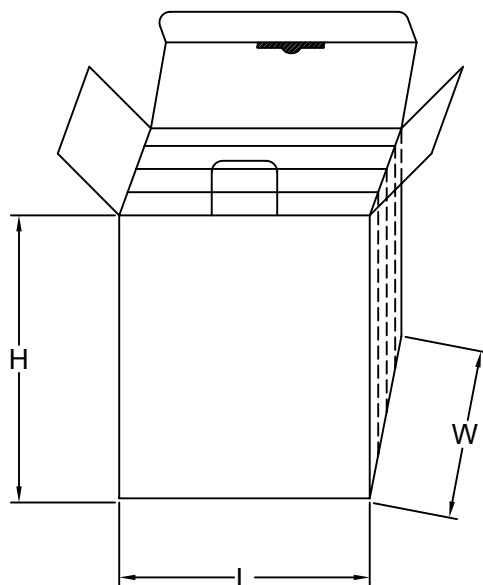

3. 10 INNER BOXES / CARTON
4. CARTON SIZE : L X W X H 58cm X 34cm x 35cm

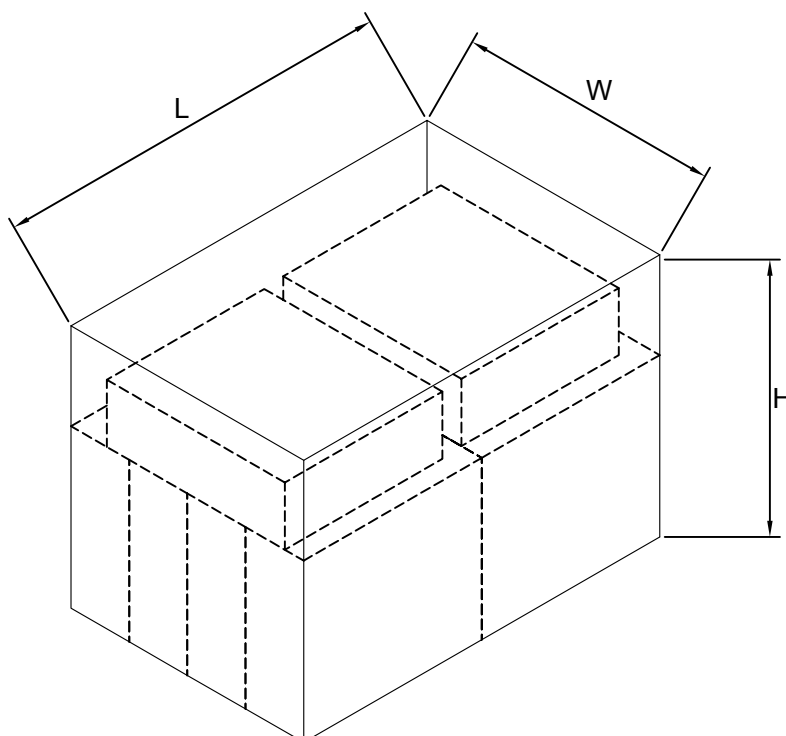

Recommended Soldering Conditions**1. Hand Solder**

Basic spec is $\leq 320^{\circ}\text{C}$ 3 sec one time only.

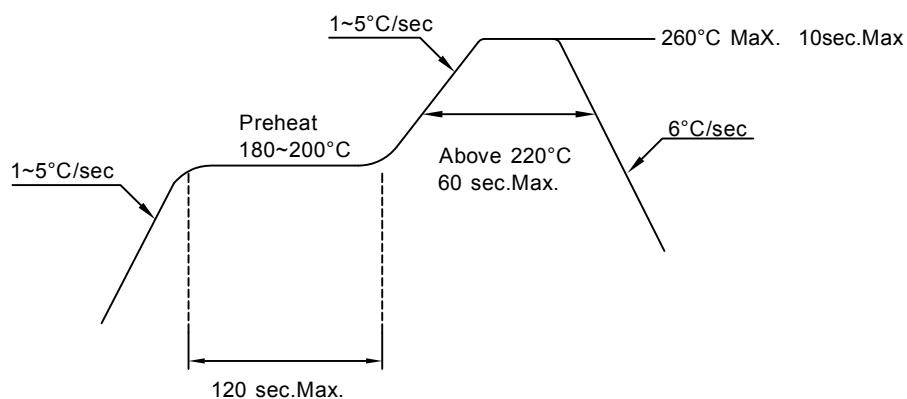
2. PB-Free Reflow Solder**Note:**

- 1.Reflow soldering should not be done more than two times.
- 2.When soldering,do not put stress on the LEDs during heating.
- 3.After soldering,do not warp the circuit board.

Precautions For Use:**Storage time:**

1. Calculated shelf life before opening is 18 months at $< 30^{\circ}\text{C}$ and $< 90\%$ relative humidity (RH)
2. After bag is opened, devices which will be subjected to reflow soldering or other high temperature processes must be
 - a) Assembled within one years in an environment of $\leq 30^{\circ}\text{C} / 60\%$ RH, or
 - b) Stored at ambient of 10% RH or less
3. Devices are required baking before assembly if:
 - a) Humidity Indicator Card reads $>10\%$ (for level 2a -5a) or $>60\%$ (for level 2) at ambient temperature $23\pm 5^{\circ}\text{C}$
 - b) 2.a) or 2.b) doesn't meet
4. If baking is required, devices should be baked for >72 hours at $60\pm 5^{\circ}\text{C} / 5\%$ RH. Performing baking only once, and using the baked devices within 72 hours..

Drive Method:

LED is a current operated device, and therefore, requires some kind of current limiting incorporated into the driver circuit. This current limiting typically takes the form of a current limiting resistor placed in series with the LED.

Consider worst case voltage variations than could occur across the current limiting resistor. The forward current should not be allowed to change by more than 40% of its desired value.

Circuit model A

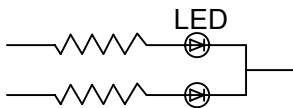

Circuit model B

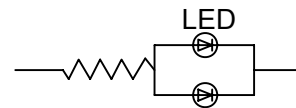

(A) Recommended circuit.

(B) The difference of brightness between LED could be found due to the VF-IF characteristics of LED.

Cleaning:

Use alcohol-based cleaning solvents such as isopropyl alcohol to clean the LED.

ESD(Electrostatic Discharge):

Static Electricity or power surge will damage the LED. Use of a conductive wrist band or anti-electrostatic glove is recommended when handling these LED. All devices, equipment and machinery must be properly grounded.

Reliability Test:

Classification	Test Item	Test Condition	Sample Size
Endurance Test	Operating Life Test	1.Ta=25°C 2.If=5mA 3.t=1000 hrs (-24hrs,+72hrs)	22
	High Temperature Storage Test	1.Ta=100°C±5°C 2.t=1000 hrs (-24hrs,+72hrs)	22
	Low Temperature Storage Test	1.Ta=-40°C±5°C 2.t=1000 hrs (-24hrs,+72hrs)	22
	High Temperature High Humidity Storage Test	1.Ta=85°C 2.RH=85% 3.t=1000hrs(-24hrs,+72hrs)	22
Environmental Test	Thermal Shock Test	1.Ta=100°C±5°C ~ -40°C±5°C 20min/ 10sec / 20min 2.total 100 cycles	22
	Temperature Cycling	1.100°C±5°C ~ -40°C±5°C 30mins / 5mins / 30mins 2.100 Cyeles	22
	IR Reflow	1.T=260°C Max. 10sec.Max. 2. 6 Min	22