

1.5MHz, 1A Synchronous Buck Regulator

Features

- **1A Output Current**
- **Wide 2.7V~6.0V Input Voltage**
- **Fixed 1.5MHz Switching Frequency**
- **Low Dropout Operating at 100% Duty Cycle**
- **Synchronous Rectifier**
- **0.6V Reference Voltage**
- **<0.5mA Input Current During Shutdown**
- **Short-Circuit Protection**
- **Over-Temperature Protection**
- **Available in TDFN2x2-6 Packages**
- **Lead Free and Green Devices Available (RoHS Compliant)**

General Description

APW7178A is a 1.5MHz high efficiency monolithic synchronous buck regulator. Design with current mode scheme, the APW7178A is stable with ceramic output capacitor. Input voltage from 2.7V to 6.0V makes the APW7178A ideally suited for single Li-Ion battery powered applications. 100% duty cycle provides low dropout operation, extending battery life in portable electrical devices. The internally fixed 1.5MHz operating frequency allows the using of small surface mount inductors and capacitors. The synchronous switches included inside increase the efficiency and eliminate the need of an external Schottky diode.

The APW7178A is available in TDFN2x2-6 packages.

Simplified Application Circuit

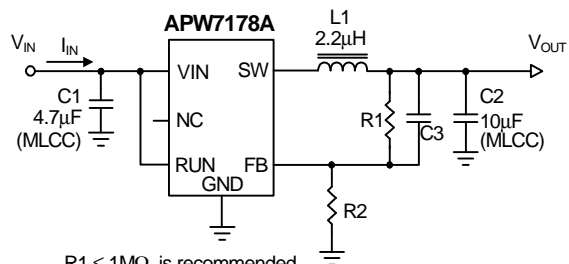

$R1 \leq 1M\Omega$ is recommended

$R2 \leq 200K\Omega$ is recommended

Place C1 closed VIN/GND. Without via hole is recommended.

Applications

- **HD STB**
- **BT Mouse**
- **PND Instrument**
- **Portable Instrument**

Pin Configuration

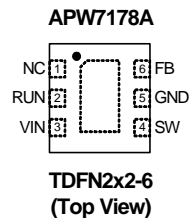

ANPEC reserves the right to make changes to improve reliability or manufacturability without notice, and advise customers to obtain the latest version of relevant information to verify before placing orders.

Ordering and Marking Information

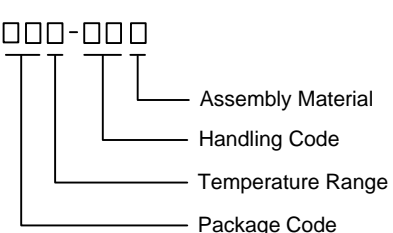
<p>APW7178A □□□-□□□</p>  <p>Assembly Material Handling Code Temperature Range Package Code</p>	<p>Package Code QB: TDFN2x2-6 Operating Ambient Temperature Range I : -40 to 85 °C Handling Code TR : Tape & Reel Assembly Material G : Halogen and Lead Free Device</p>		
<p>APW7178AQB : <table border="1" style="display: inline-table; vertical-align: middle;"><tr><td style="padding: 2px;">78A</td></tr><tr><td style="padding: 2px;">X</td></tr></table> X - Date Code</p>		78A	X
78A			
X			

Note: ANPEC lead-free products contain molding compounds/die attach materials and 100% matte tin plate termination finish; which are fully compliant with RoHS. ANPEC lead-free products meet or exceed the lead-free requirements of IPC/JEDEC J-STD-020D for MSL classification at lead-free peak reflow temperature. ANPEC defines "Green" to mean lead-free (RoHS compliant) and halogen free (Br or Cl does not exceed 900ppm by weight in homogeneous material and total of Br and Cl does not exceed 1500ppm by weight).

Absolute Maximum Ratings (Note 1)

Symbol	Parameter	Rating	Unit
V_{IN}	Input Bias Supply Voltage (VIN to GND)	-0.3 ~ 7	V
	RUN, FB, SW to GND Voltage	-0.3 ~ $V_{IN}+0.3$	V
P_D	Power Dissipation	Internally Limited	W
	Maximum Junction Temperature	150	°C
T_{STG}	Storage Temperature	-65 ~ 150	°C
T_{SDR}	Maximum Lead Soldering Temperature, 10 Seconds	260	°C

Note1: Stresses beyond those listed under "absolute maximum ratings" may cause permanent damage to the device. These are stress ratings only and functional operation of the device at these or any other conditions beyond those indicated under "recommended operating conditions" is not implied. Exposure to absolute maximum rating conditions for extended periods may affect device reliability.

Thermal Characteristics

Symbol	Parameter	Typical Value	Unit
θ_{JA}	Junction-to-Ambient Resistance in Free Air ^(Note 2) TDFN2x2-6	165	°C/W

Note 2: θ_{JA} is measured with the component mounted on a high effective thermal conductivity test board in free air.

Recommended Operating Conditions (Note 3)

Symbol	Parameter	Range	Unit
V_{IN}	Input Bias Supply Voltage (VIN to GND)	2.7 ~ 6	V
V_{OUT}	Converter Output Voltage	0.6 ~ V_{IN}	V
I_{OUT}	Converter Output Current	0 ~ 1	A
L1	Converter Output Inductor	1.0 ~ 10	μH

Recommended Operating Conditions (Note 3) (Cont.)

Symbol	Parameter	Range	Unit
C _{IN}	Converter Input Capacitor	4.7 ~100	μF
C _{OUT}	Converter Output Capacitor	4.7 ~100	μF
T _A	Ambient Temperature	-40 ~ 85	°C
T _J	Junction Temperature	-40 ~ 125	°C

Note 3: Refer to the typical application circuit

Electrical Characteristics

Unless otherwise specified, these specifications apply over V_{IN}=3.6V and T_A= 25 °C.

Symbol	Parameter	Test Conditions	APW7178A			Unit
			Min.	Typ.	Max.	
SUPPLY VOLTAGE AND CURRENT						
V _{IN}	Input Voltage Range		2.7	-	6	V
I _{SD}	Shutdown Input Current	RUN = GND	-	-	0.5	μA
POWER-ON-RESET (POR) and LOCKOUT VOLTAGE THRESHOLDS						
	UVLO Threshold		2.1	2.35	2.6	V
	UVLO Hysteresis		-	0.1	-	V
REFERENCE VOLTAGE						
V _{REF}	Reference Voltage	V _{IN} =2.7V~6V, T _A = -40~85 °C	0.588	0.6	0.612	V
	Output Voltage Accuracy	0A < I _{OUT} < 1A	-2.5	-	+2.5	%
I _{FB}	FB Input Current		-50	-	50	nA
INTERNAL POWER MOSFETS						
F _{SW}	Switching Frequency		1.2	1.5	1.8	MHz
	Foldback Frequency	V _{FB} = 0.1V	-	210	-	kHz
	Foldback Threshold Voltage on FB	V _{FB} Falling	-	0.2	-	V
	Foldback Hysteresis		-	50	-	mV
R _{P-FET}	High Side N-FET Switch ON Resistance	I _{SW} =200mA	-	0.28	-	Ω
R _{N-FET}	Low Side P-FET Switch ON Resistance	I _{SW} =200mA	-	0.25	-	Ω
	Minimum On-Time		-	-	100	ns
	Maximum Duty Cycle		-	-	100	%
PROTECTION						
I _{LIM}	Maximum Inductor Current-Limit	I _{P-FET} , 2.7V V _{IN} 6V	1.4	1.6	-	A
T _{OTP}	Over-Temperature Protection	T _J Rising	-	150	-	°C
	Over-Temperature Protection Hysteresis	T _J Falling	-	30	-	

Electrical Characteristics (Cont.)

Unless otherwise specified, these specifications apply over $V_{IN}=3.6V$ and $T_A=25\text{ }^\circ\text{C}$.

Symbol	Parameter	Test Conditions	APW7178A			Unit
			Min.	Typ.	Max.	
START-UP AND SHUTDOWN						
T_{SS}	Soft-Start Duration	(Note 4)	-	0.7	-	ms
	RUN Input High Threshold	$V_{IN} = 2.7V\sim 6V$	-	-	1	V
	RUN Input Low Threshold	$V_{IN} = 2.7V\sim 6V$	0.4	-	-	V
	RUN Leakage Current	$V_{RUN} = 5V, V_{IN} = 5V$	-1	-	1	μA

Typical Operating Characteristics

(Refer to the application circuit in the section “Typical Application Circuits”, $V_{IN}=3.6V$, $V_{OUT}=1.8V$, $T_A=25^{\circ}C$ unless otherwise specified)

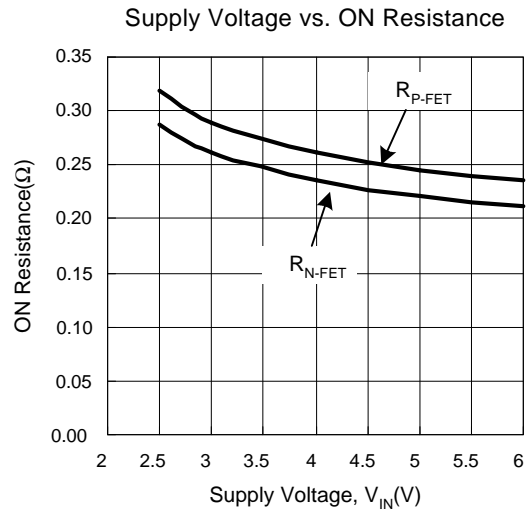
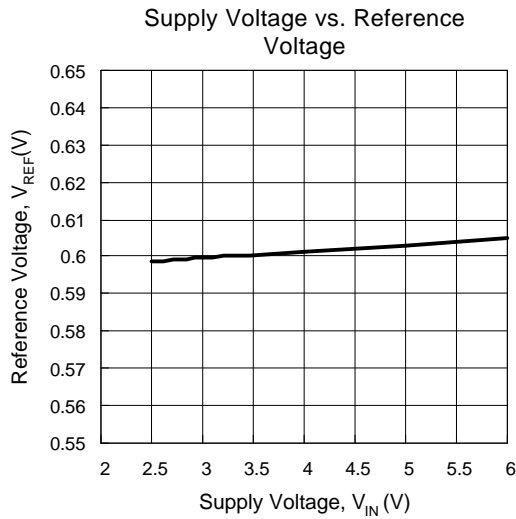
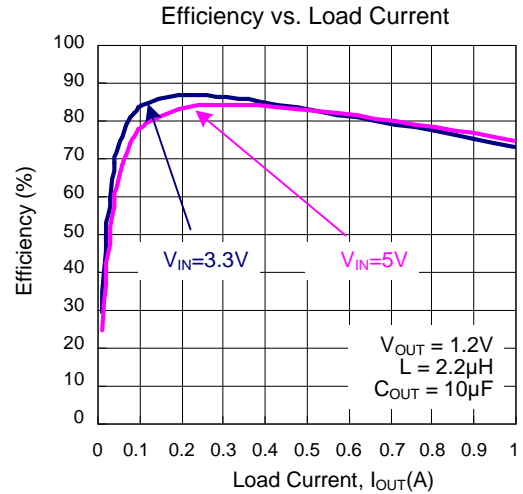
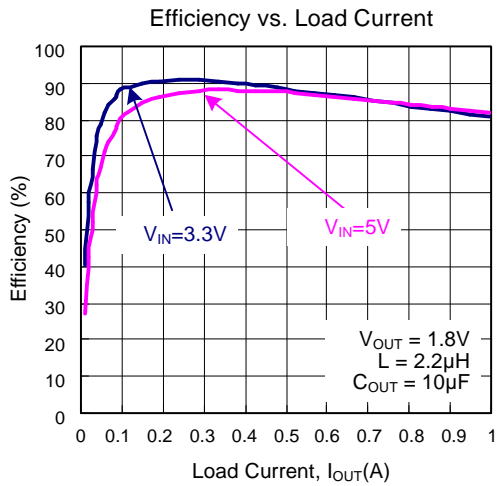

Operating Waveforms

(Refer to the application circuit in the section "Typical Application Circuits", $V_{IN}=3.6V$, $V_{OUT}=1.8V$, $T_A=25^\circ C$ unless otherwise specified)

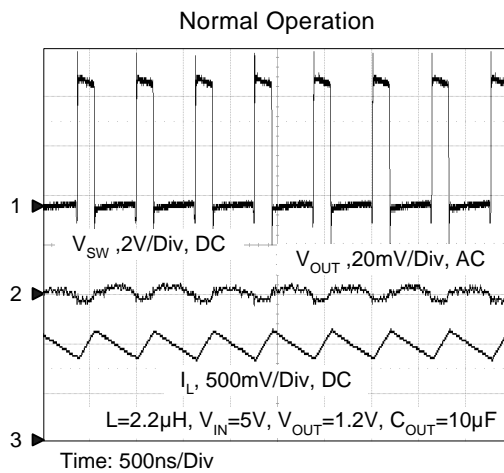
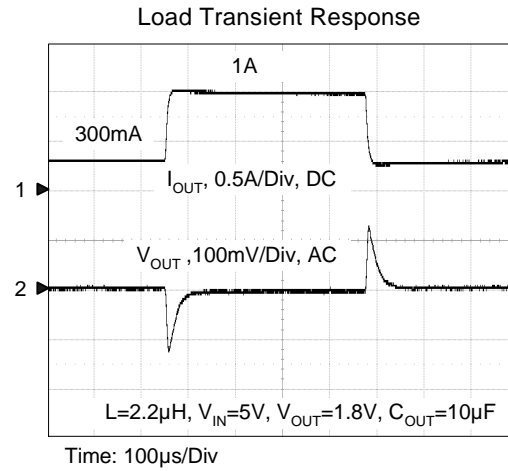
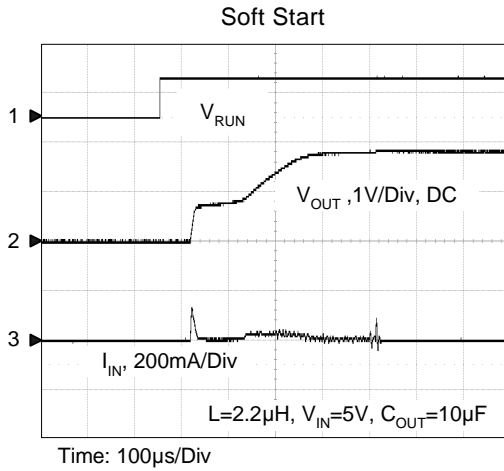

Pin Description

PIN		FUNCTION
NO.	NAME	
1	NC	No Internal Connection.
2	RUN	Enable Control Input. Forcing this pin above 1.0V enables the device. Forcing this pin below 0.4V shuts it down. In shutdown, all functions are disabled to decrease the supply current below 0.5μA. Do not leave RUN pin floating.
3	VIN	Device and Converter Supply Pin. Must be closely decoupled to GND with a 4.7μF or greater ceramic capacitor.
4	SW	Switch Node Connected to Inductor. This pin connects to the drains of the internal main and synchronous power MOSFETs switches.
5	GND	Power and Signal Ground.
6	FB	The feedback voltage is decided by an external resistive divider across the output.

Block Diagram

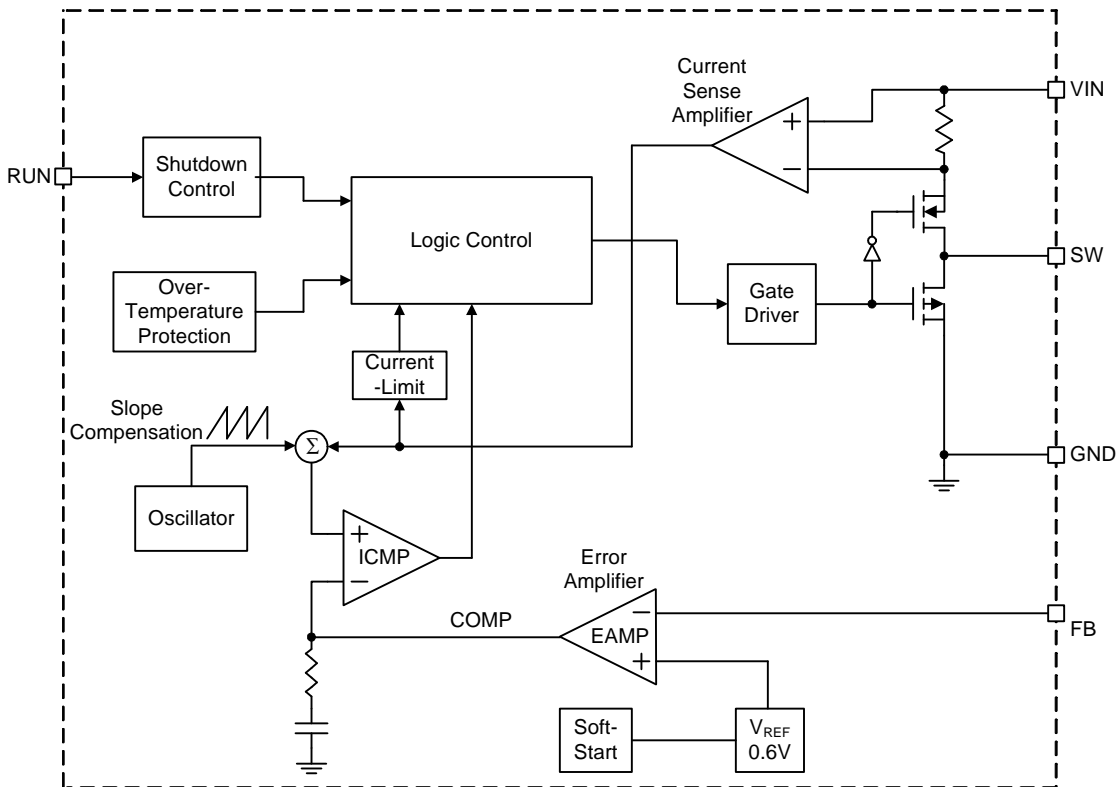

Typical Application Circuit

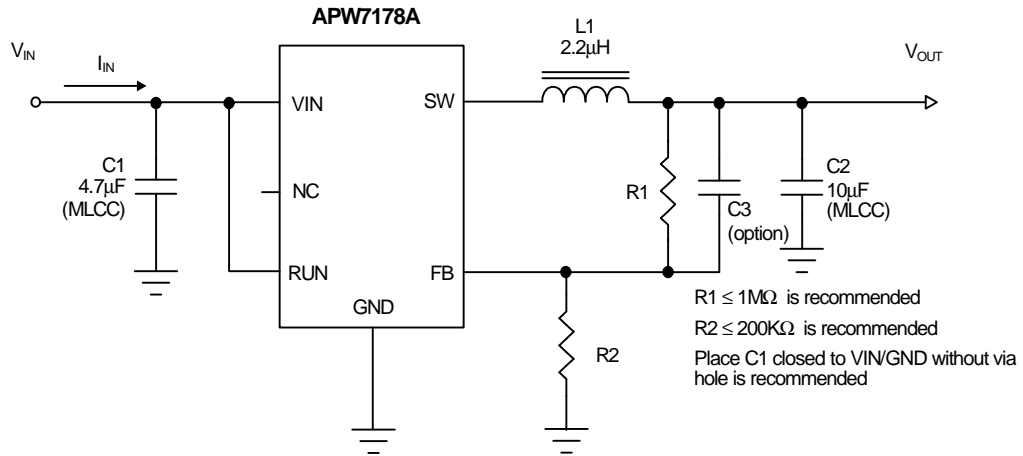

Function Description

Main Control Loop

The APW7178A is a constant frequency, synchronous rectifier and current-mode switching regulator. In normal operation, the internal P-channel power MOSFET is turned on each cycle. The peak inductor current at which ICMP turn off the P-FET is controlled by the voltage on the COMP node, which is the output of the error amplifier (EAMP). An external resistive divider connected between V_{OUT} and ground allows the EAMP to receive an output feedback voltage V_{FB} at FB pin. When the load current increases, it causes a slightly decrease in V_{FB} relative to the 0.6V reference, which in turn causes the COMP voltage to increase until the average inductor current matches the new load current.

Enable/Shutdown

Driving RUN to the ground places the APW7178A in shutdown mode. When in shutdown, the internal power MOSFETs turn off, all internal circuitry shuts down and the quiescent supply current reduces to 0.5 μ A maximum.

Slope Compensation and Inductor Peak Current

The APW7178A is a peak current mode PWM step down converter. To prevent sub-harmonic oscillations, the APW7178A sense the peak current and add slope compensation to stable the converter. It is accomplished internally by adding a compensating ramp to the inductor current signal at duty cycles in excess of 40%. Normally, this results in a reduction of maximum inductor peak current for duty cycles > 40%. However, the APW7178A uses a special scheme that counteracts this compensating ramp, which allows the maximum inductor peak current to remain unaffected throughout all duty cycles.

Over-Temperature Protection (OTP)

The over-temperature circuit limits the junction temperature of the APW7178A. When the junction temperature exceeds 150°C, a thermal sensor turns off the both power MOSFETs, allowing the devices to cool. The thermal sensor allows the converters to start a soft-start process and regulate the output voltage again after the junction temperature cools by 30°C. The OTP is designed with a 30°C hysteresis to lower the average Junction Temperature (T_J) during continuous thermal overload conditions, increasing the lifetime of the device.

Dropout Operation

As the input supply voltage decreases to a value approaching the output voltage, the duty cycle increases toward the maximum on time. Further, reduction of the supply voltage forces the main switch to remain on for more than one cycle until it reaches 100% duty cycle. The input voltage minus the voltage drop will determine the output voltage across the P-FET and the inductor.

An important detail to remember is that on resistance of P-FET switch will increase at low input supply voltage. Therefore, the user should calculate the power dissipation when the APW7178A is used at 100% duty cycle with low input voltage.

Application Information

Input Capacitor Selection

Because buck converters have a pulsating input current, a low ESR input capacitor is required. This results in the best input voltage filtering, minimizing the interference with other circuits caused by high input voltage spikes. Also, the input capacitor must be sufficiently large to stabilize the input voltage during heavy load transients. For good input voltage filtering, usually a 4.7μF input capacitor is sufficient. It can be increased without any limit for better input-voltage filtering. Ceramic capacitors show better performance because of the low ESR value, and they are less sensitive against voltage transients and spikes compared to tantalum capacitors. Place the input capacitor as close as possible to the input and GND pin of the device for better performance.

Inductor Selection

For high efficiencies, the inductor should have a low DC resistance to minimize conduction losses. Especially at high-switching frequencies the core material has a higher impact on efficiency. When using small chip inductors, the efficiency is reduced mainly due to higher inductor core losses. This needs to be considered when selecting the appropriate inductor. The inductor value determines the inductor ripple current. The larger the inductor value, the smaller the inductor ripple current and the lower the conduction losses of the converter. Conversely, larger inductor values cause a slower load transient response. A reasonable starting point for setting ripple current, ΔI_L , is 40% of maximum output current. The recommended inductor value can be calculated as below:

$$L \geq \frac{V_{OUT} \left(1 - \frac{V_{OUT}}{V_{IN}}\right)}{F_{SW} \cdot \Delta I_L}$$

$$I_{L(MAX)} = I_{OUT(MAX)} + 1/2 \times \Delta I_L$$

To avoid the saturation of the inductor, the inductor should be rated at least for the maximum output current of the converter plus the inductor ripple current.

Output Voltage Setting

In the adjustable version, the output voltage is set by a resistive divider. The external resistive divider is connected to the output, allowing remote voltage sensing as

shown in “Typical Application Circuits”. A suggestion of maximum value of R2 is 200kΩ to keep the minimum current that provides enough noise rejection ability through the resistor divider. The output voltage can be calculated as below:

$$V_{OUT} = V_{REF} \cdot \left(1 + \frac{R1}{R2}\right) = 0.6 \cdot \left(1 + \frac{R1}{R2}\right)$$

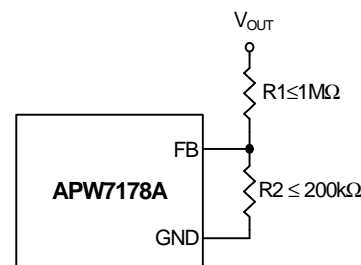

Output Capacitor Selection

The current-mode control scheme of the APW7178A allows the use of tiny ceramic capacitors. The higher capacitor value provides the good load transients response. Ceramic capacitors with low ESR values have the lowest output voltage ripple and are recommended. If required, tantalum capacitors may be used as well. The output ripple is the sum of the voltages across the ESR and the ideal output capacitor.

$$\Delta V_{OUT} \cong \frac{V_{OUT} \cdot \left(1 - \frac{V_{OUT}}{V_{IN}}\right)}{F_{SW} \cdot L} \cdot \left(ESR + \frac{1}{8 \cdot F_{SW} \cdot C_{OUT}}\right)$$

When choosing the input and output ceramic capacitors, choose the X5R or X7R dielectric formulations. These dielectrics have the best temperature and voltage characteristics of all the ceramics for a given value and size.

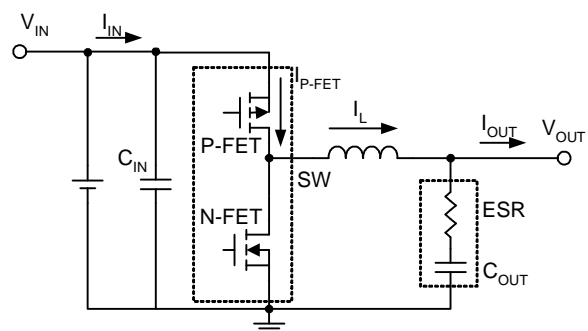

Application Information (Cont.)

Output Capacitor Selection (Cont.)

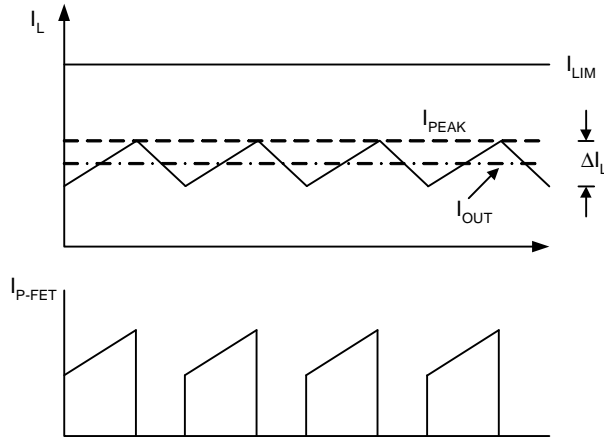

Thermal Consideration

In most applications, the APW7178A does not dissipate much heat due to its high efficiency. But, in applications where the APW7178A is running at high ambient temperature with low supply voltage and high duty cycles, the heat dissipated may exceed the maximum junction temperature of the part. If the junction temperature reaches approximately 150°C, both power switches will be turned off and the SW node will become high impedance.

To avoid the APW7178A from exceeding the maximum junction temperature, the user will need to do some thermal analysis. The goal of the thermal analysis is to determine whether the power dissipated exceeds the maximum junction temperature of the part. The power dissipated by the part is approximated:

$$P_D \cong I_{OUT}^2 \times (R_{P-FET} \times D + R_{N-FET} \times (1-D))$$

The temperature rise is given by:

$$T_R = (P_D)(\theta_{JA})$$

Where P_D is the power dissipated by the regulator, D is duty cycle of main switch

$$D = V_{OUT}/V_{IN}$$

The θ_{JA} is the thermal resistance from the junction of the die to the ambient temperature. The junction temperature, T_J , is given by:

$$T_J = T_A + T_R$$

Where T_A is the ambient temperature.

The maximum power dissipation on the device can be shown as the following figure:

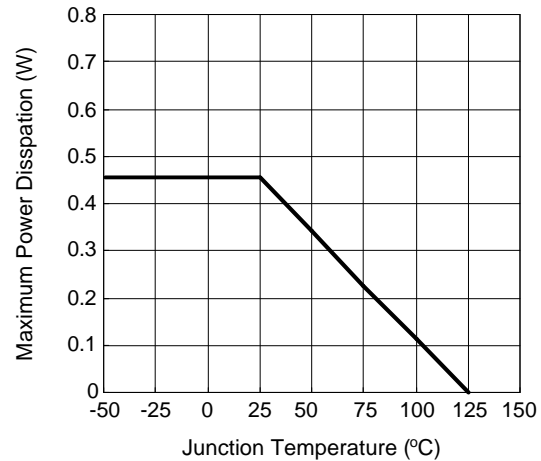

Layout Consideration

For all switching power supplies, the layout is an important step in the design; especially at high peak currents and switching frequencies. If the layout is not carefully done, the regulator might show noise problems and duty cycle jitter.

1. The input capacitor should be placed close to the VIN and GND. Connecting the capacitor and VIN/GND with short and wide trace without any via holes for good input voltage filtering. The distance between VIN/GND to capacitor less than 2mm respectively is recommended.
2. To minimize copper trace connections that can inject noise into the system, the inductor should be placed as close as possible to the SW pin to minimize the noise coupling into other circuits.
3. The output capacitor should be placed close to VOUT and GND.
4. Since the feedback pin and network is a high impedance circuit the feedback network should be routed away from the inductor. The feedback pin and feedback network should be shielded with a ground plane or trace to minimize noise coupling into this circuit.
5. A star ground connection or ground plane minimizes ground shifts and noise is recommended.

Package Information

TDFN2x2-6

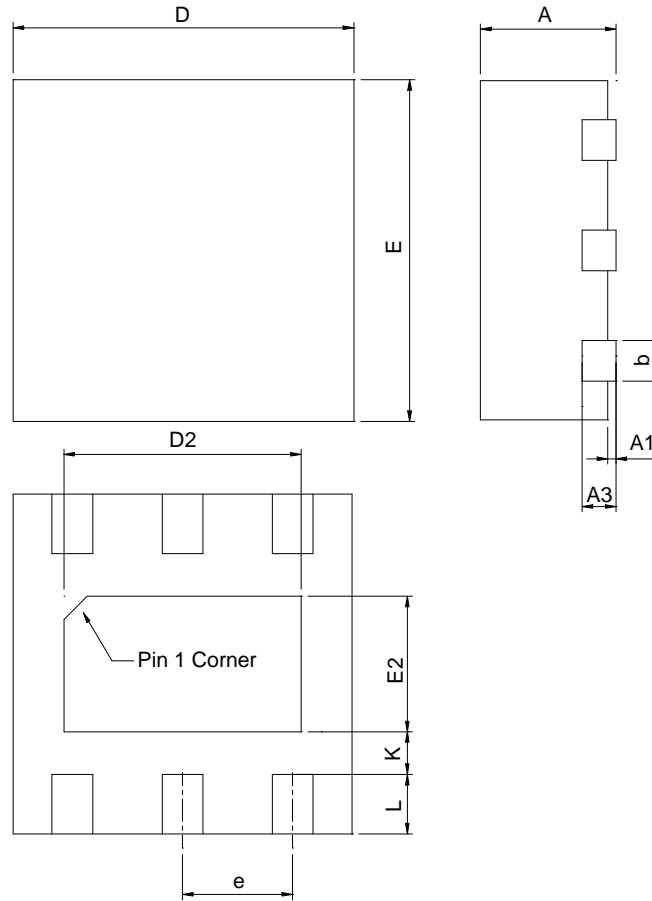

SYMBOL	TDFN2x2-6			
	MILLIMETERS		INCHES	
	MIN.	MAX.	MIN.	MAX.
A	0.70	0.80	0.028	0.031
A1	0.00	0.05	0.000	0.002
A3	0.20 REF		0.008 REF	
b	0.18	0.30	0.007	0.012
D	1.90	2.10	0.075	0.083
D2	1.00	1.60	0.039	0.063
E	1.90	2.10	0.075	0.083
E2	0.60	1.00	0.024	0.039
e	0.65 BSC		0.026 BSC	
L	0.30	0.45	0.012	0.018
K	0.20		0.008	

Note : 1. Followed from JEDEC MO-229 WCCC.

Carrier Tape & Reel Dimensions

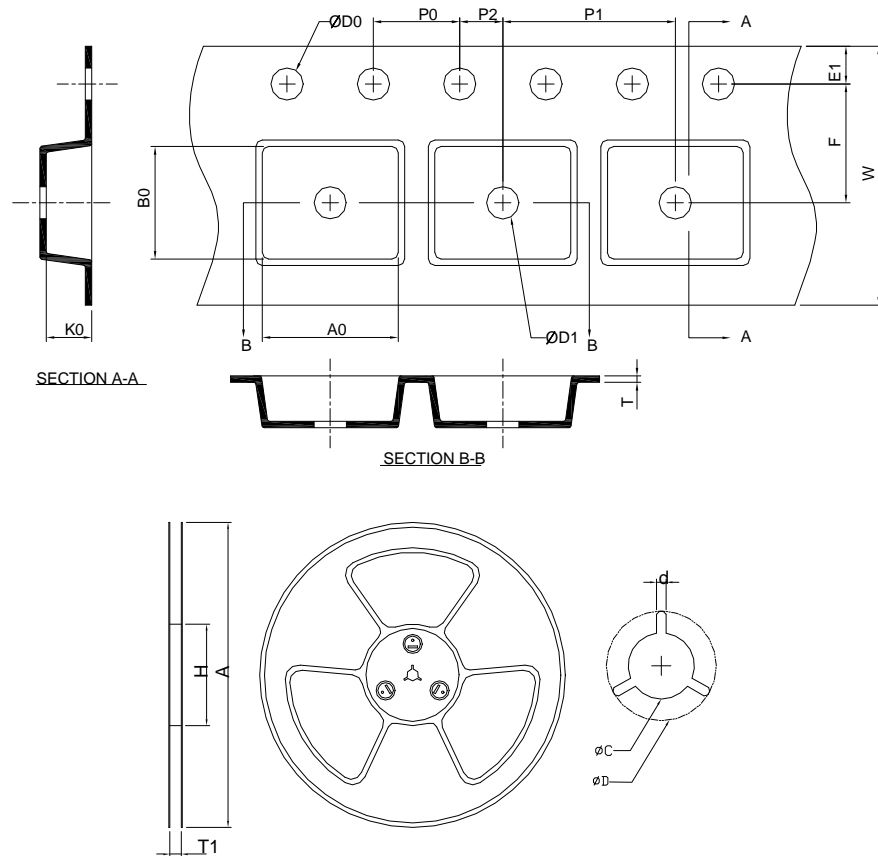

Application	A	H	T1	C	d	D	W	E1	F
TDFN2x2-6	178.0 ±0.00	50 MIN.	8.4+2.00 -0.00	13.0+0.50 -0.20	1.5 MIN.	20.2 MIN.	8.0 ±0.20	1.75 ±0.10	3.5 ±0.05
	P0	P1	P2	D0	D1	T	A0	B0	K0
	4.0 ±0.10	4.0 ±0.10	2.0 ±0.05	1.5+0.10 -0.00	1.5 MIN.	0.6+0.00 -0.40	2.35 MIN	2.35 MIN	1.30 ±0.20

(mm)

Devices Per Unit

Package Type	Unit	Quantity
TDFN2x2-6	Tape & Reel	3000

Taping Direction Information

TDFN2x2-6

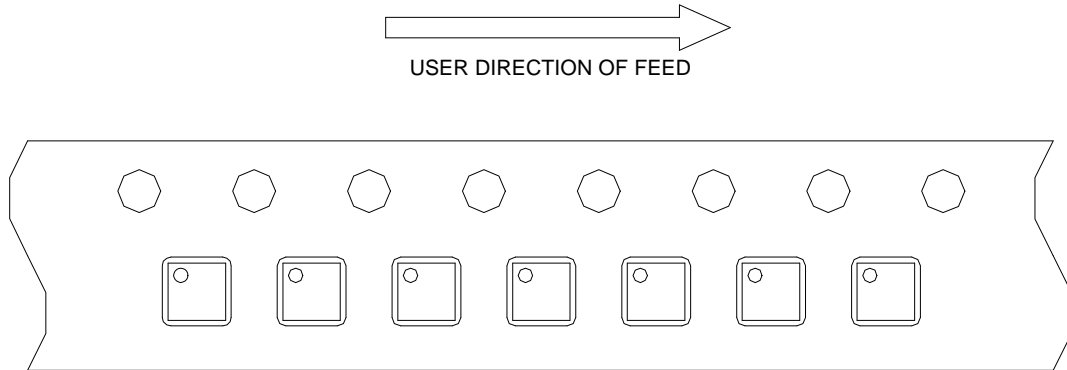

Classification Profile

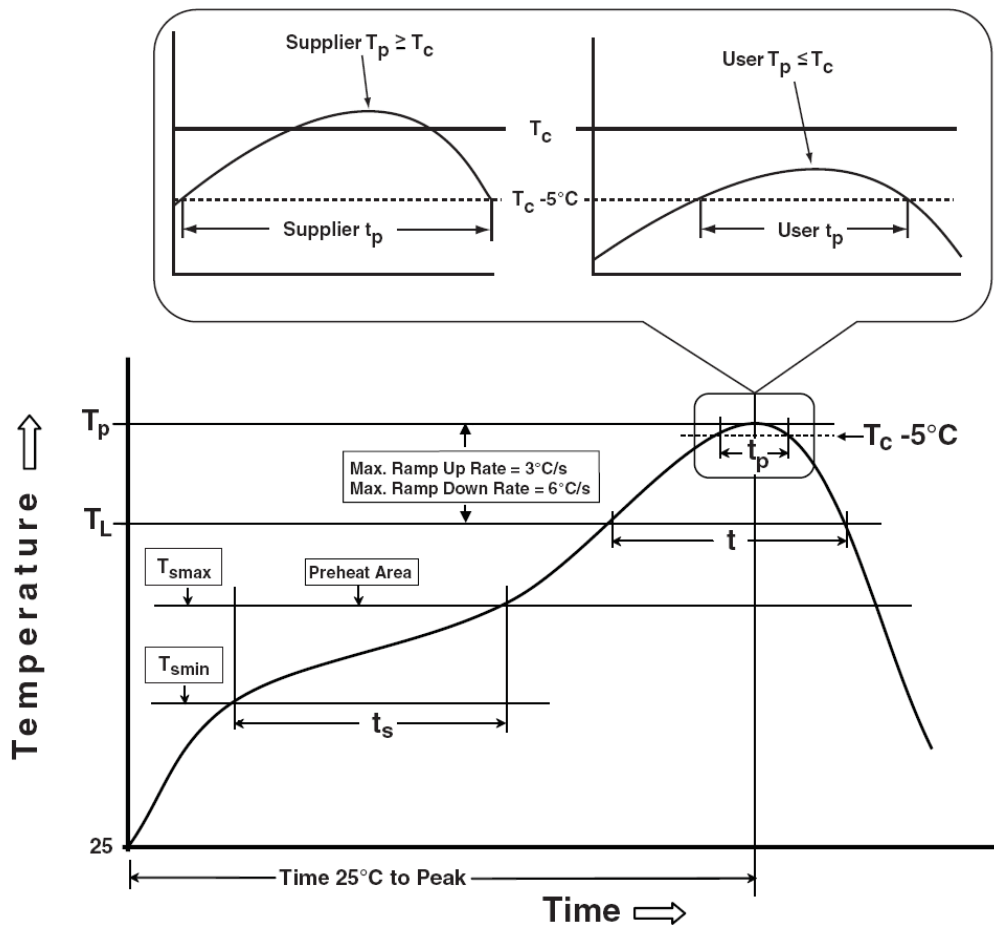

Classification Reflow Profiles

Profile Feature	Sn-Pb Eutectic Assembly	Pb-Free Assembly
Preheat & Soak Temperature min (T_{smin}) Temperature max (T_{smax}) Time (T_{smin} to T_{smax}) (t_s)	100 °C 150 °C 60-120 seconds	150 °C 200 °C 60-120 seconds
Average ramp-up rate (T_{smax} to T_p)	3 °C/second max.	3 °C/second max.
Liquidous temperature (T_L) Time at liquidous (t_L)	183 °C 60-150 seconds	217 °C 60-150 seconds
Peak package body Temperature (T_p)*	See Classification Temp in table 1	See Classification Temp in table 2
Time (t_p)** within 5°C of the specified classification temperature (T_c)	20** seconds	30** seconds
Average ramp-down rate (T_p to T_{smax})	6 °C/second max.	6 °C/second max.
Time 25°C to peak temperature	6 minutes max.	8 minutes max.
* Tolerance for peak profile Temperature (T_p) is defined as a supplier minimum and a user maximum. ** Tolerance for time at peak profile temperature (t_p) is defined as a supplier minimum and a user maximum.		

Table 1. SnPb Eutectic Process – Classification Temperatures (T_c)

Package Thickness	Volume mm ³ <350	Volume mm ³ ≥350
<2.5 mm	235 °C	220 °C
≥2.5 mm	220 °C	220 °C

Table 2. Pb-free Process – Classification Temperatures (T_c)

Package Thickness	Volume mm ³ <350	Volume mm ³ 350-2000	Volume mm ³ >2000
<1.6 mm	260 °C	260 °C	260 °C
1.6 mm – 2.5 mm	260 °C	250 °C	245 °C
≥2.5 mm	250 °C	245 °C	245 °C

Reliability Test Program

Test item	Method	Description
SOLDERABILITY	JESD-22, B102	5 Sec, 245°C
HOLT	JESD-22, A108	1000 Hrs, Bias @ $T_j=125^\circ\text{C}$
PCT	JESD-22, A102	168 Hrs, 100%RH, 2atm, 121°C
TCT	JESD-22, A104	500 Cycles, -65°C~150°C
HBM	MIL-STD-883-3015.7	VHBM 2KV
MM	JESD-22, A115	VMM 200V
Latch-Up	JESD 78	10ms, 1 _{tr} 100mA

Customer Service

Anpec Electronics Corp.

Head Office :

No.6, Dusing 1st Road, SBIP,
Hsin-Chu, Taiwan, R.O.C.
Tel : 886-3-5642000
Fax : 886-3-5642050

Taipei Branch :

2F, No. 11, Lane 218, Sec 2 Jhongsing Rd.,
Sindian City, Taipei County 23146, Taiwan
Tel : 886-2-2910-3838
Fax : 886-2-2917-3838