



REV.	ECN NO.	REVISED	DATE

NOTE:

1.MATERIAL:

- a.HOUSING:LCP UL94V-0
- b.CONTACT:PHOSPHOR BRONZE
(SURFACE PLATING:Sn100u"-120u")

2.ELECTRIC:

- a.CONTACT RESISTANCE: 30 MILLIOHMS MAX
- b.INSULATION RESISTANCE: 1000 MEGA OHMS MIN
- c.DIELECTNIC VOLTAGE: 500V AC ONE SEC LEVEL
- d.OPERATING TEMPERATURE: -25°C~ +85°C

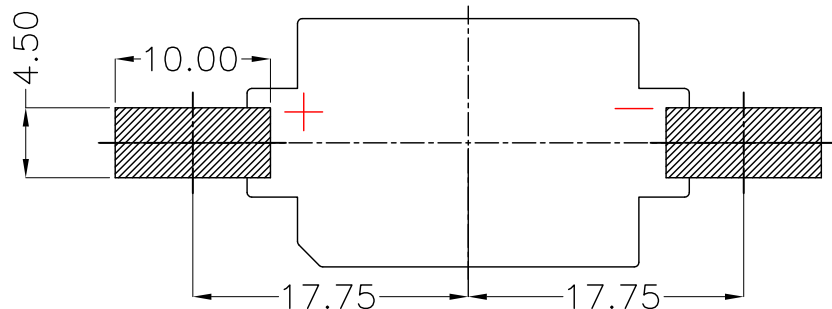
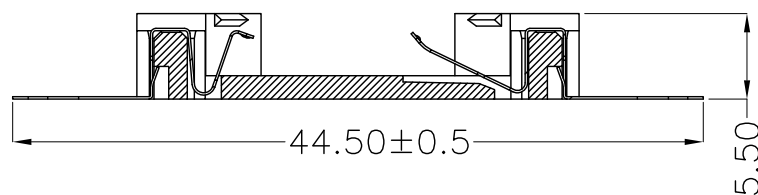
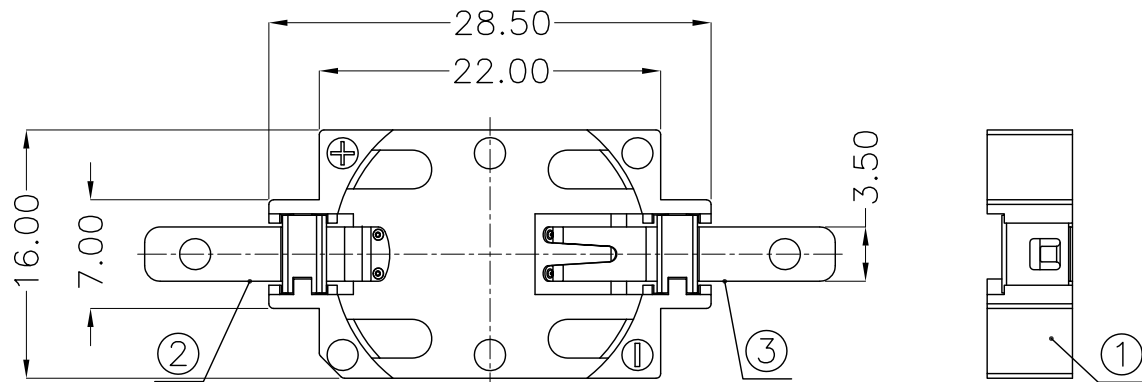

PCB Layout Diagram
Top View

ORDERING INFORMATION
BS-06-B***007

电池座系列

BS-06系列

SMT 180° TYPE

PLATING:
A-Au1U"
J-Ni100U"~120U"
K-Sn100U"~120U"

MATERIAL:
1A-PBT BLACK
1B-PA66 BLACK
2A-PPA BROWN
2B-PPA BLACK
3A-PPS BROWN
3B-PPS BLACK
4A-LCP WHITE
4B-LCP BLACK
5A-PA6T WHITE
5B-PA6T BLACK



UNLESS OTHERWISE SPECIFIED TOLERANCES		MYOUNG 美阳 www.meiyangdz.com			
DECIMALS: X :±0.30 X.X :±0.25 X.XX :±0.20 X.XXX :±0.10	ANGLES: X :±1° X.X :±0.5°	DSND	YangFeng	DATE	2019-07-11
WEIGHT: 1.49g		CHKD	ZhouRuicai	DATE	2019-07-11
SHEET 1 OF 1		APVD	XueShunyong	DATE	2019-07-11
SCALE: 2:1		SIZE: A4	VIEW:	TITLE: BS-2032-6KCI Sn SMT	
UNIT: mm		REV.: A/1	OBJECT: MY	PART NO.: BS-06-B4BK007	
				DRAW NO.:MY-CP-0160	

NO.	PART NAME	Q'TY	MATERIAL	PLATING & COLOR
3	TERMINAL(-)	1	PHOSPHOR BRONZE, T=0.15mm	Sn Plating
2	TERMINAL(+)	1	PHOSPHOR BRONZE, T=0.15mm	Sn Plating
1	HOUSING	1	LCP	BLACK