

产品规格书

PRODUCT SPECIFICATION

Customer:

Customer's part number: KH-DW-K580-WZ

Product description: BD + GPS Antenna

Uni Link's part number: MS-BD+GPS-3

Issue Date: 2018-12-30

Note: 1575.42 / 1561MHz, SMA male , RG174 3m

Application and Features

Applications :

- 1: 1575.42 / 1561Mhz System
- 2: Global Positioning System
- 3: Vehicle fixing position

Features :

- 1: Weight is light
- 2: RHCP Polarization
- 3: RoHS compliant

INDEX

- 1、 PRODUCT TECHNICAL SPECIFICATION
- 2、 PRODUCT PICTURE
- 3、 PRODUCT SPECIFICATION CHART
- 4、 MECHANICAL CHARACTERISTICS
- 5、 DURABILITY
- 6、 PATCH TEST CURVE
- 7、 LAN TEST CURVE

1、PRODUCT TECHNICAL SPECIFICATION

Electrical Specifications	
Frequency Range (MHz)	1575.42 ± 2 / 1561 ± 2
Bandwidth (MHz)	4
Noise Figure (Typical)	1.5(+25°C±10°C)
DC current (Typical)	9.5mA(At 3.0V)
Input Impedance (Ω)	50
V.S.W.R	≤ 2.0
Gain (dBi)	28
Max Input Power (w)	5
Mechanical Specifications	
Antenna Dimension-mm (mm)	49*38
Connect Type	SMA male
Input Voltage (V)	3-5
Work Temperature °C	-40- +80
Pole Diameter-mm	Φ 40-50
Cable length-mm	3000 + / - 30
Weight (g)	90

2、PRODUCT PICTURE



3、PRODUCT SPECIFICATION CHART.

单位: mm

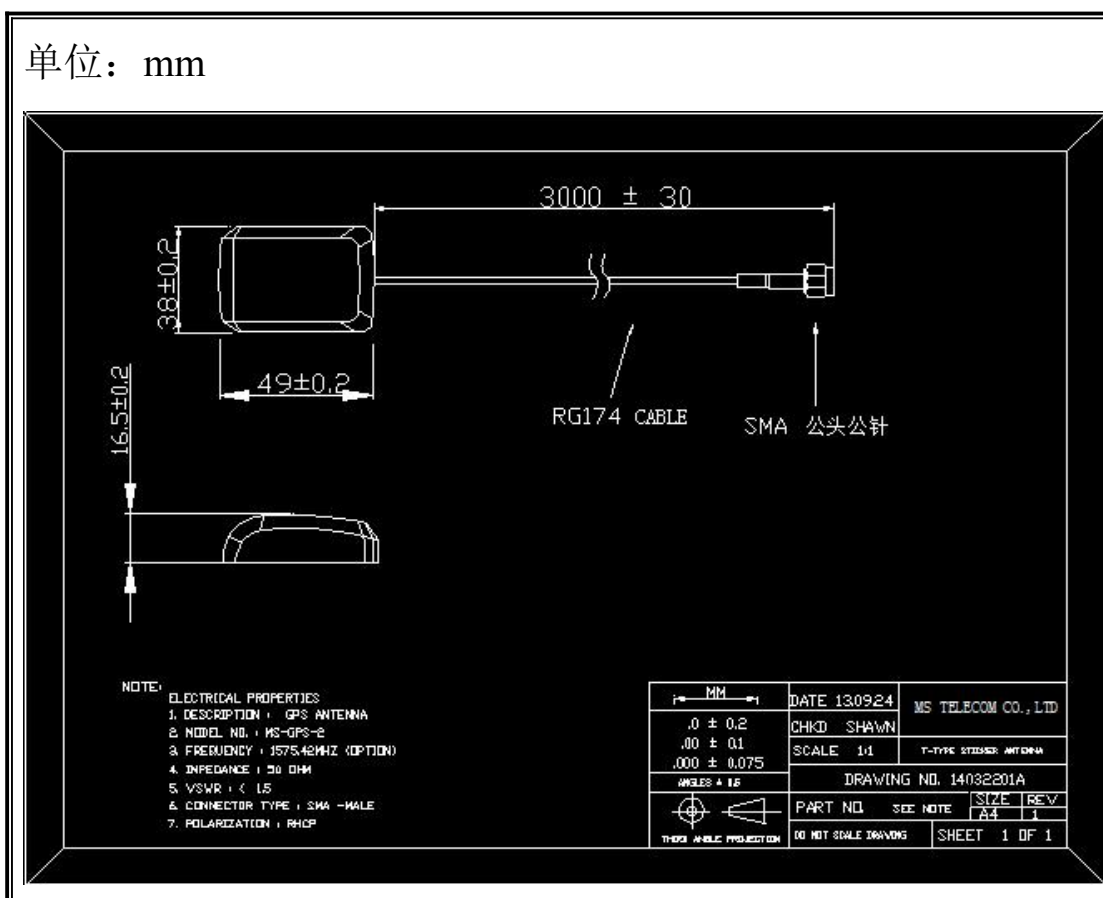

4、MECHANICAL CHARACTERISTICS)

1	BENDING TEST	Put load 120g to 30cm cable from the end of the connector, fixed joints, swaying test at an angle of 60 degrees , test features after 1000 times	after 1000 times test no visible damage
2	STRENG TEST	Put 15pounds static load to the end of the cable continue 1 minute	After test no visible damage
3	VIBRATION TEST	the X-axis direction for 120 minutes, and the Y-axis direction 120 minutes, the Z-axis direction 240 minutes as vibration testing of 1.1mm amplitude and 33.30Hz/sec of frequency	After test no visible damage

5、DURABILITY

1	HEAT TEST	85+2 °C for 24 hours, after keep in normal condition for 30min the to test.	All characteristic range is 30% of the initial value
2	HUMIDITY TEST	40+2 °C 90-95%RH for 24hours, after keep in normal condition for 30min the to test.	
3	COLD TEST	-40+2 °C for 24hours, after keep in normal condition for 30min the to test.	

6、Patch Test Curve

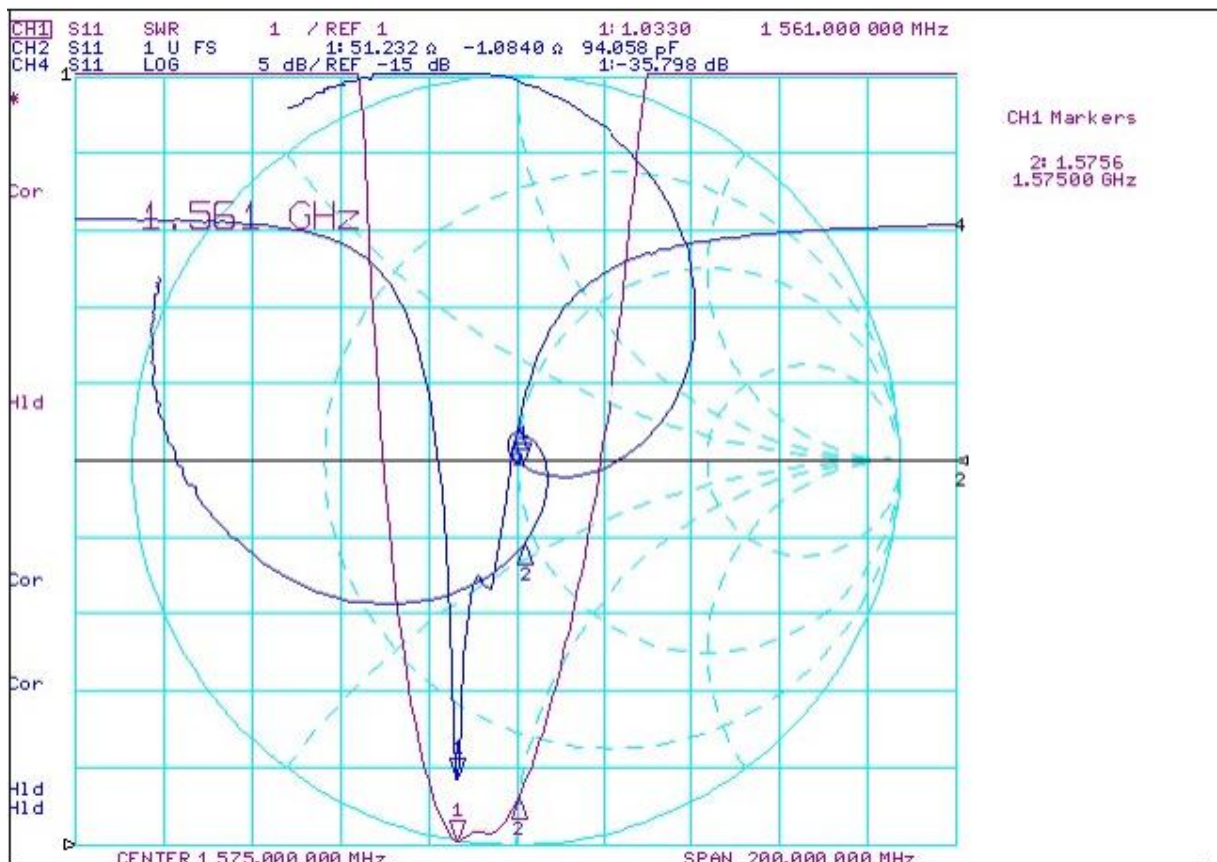

7、LAN Test Curve

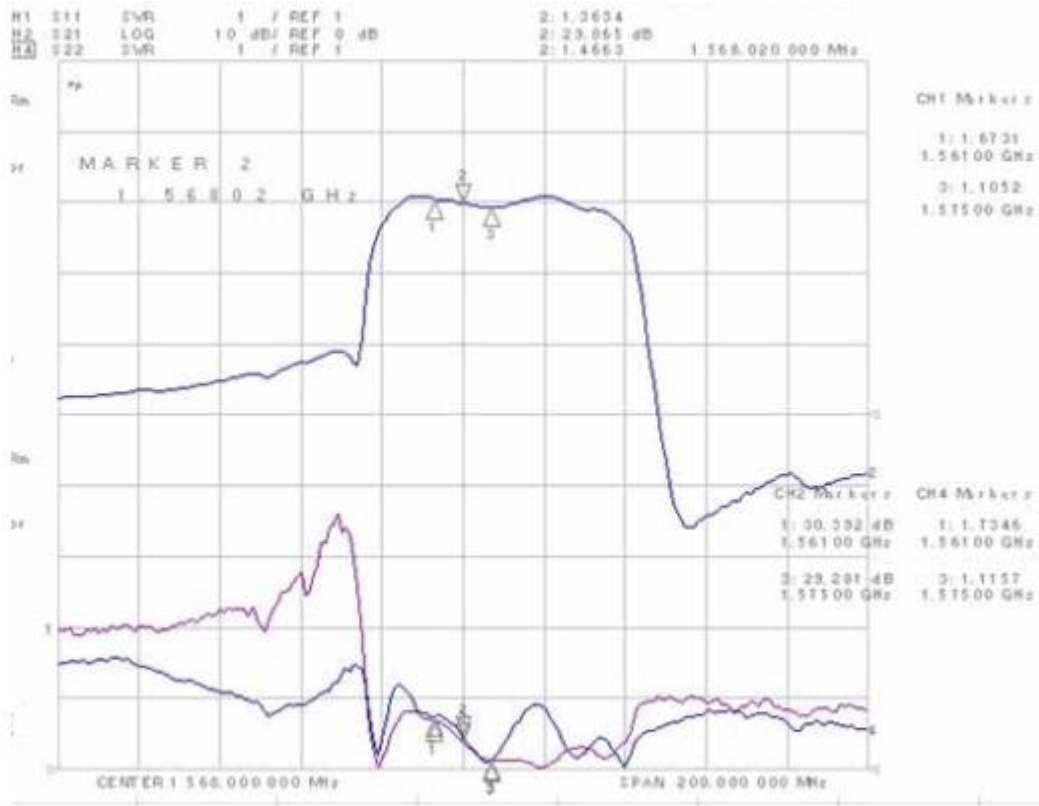

Gain Figure :S21=29dB

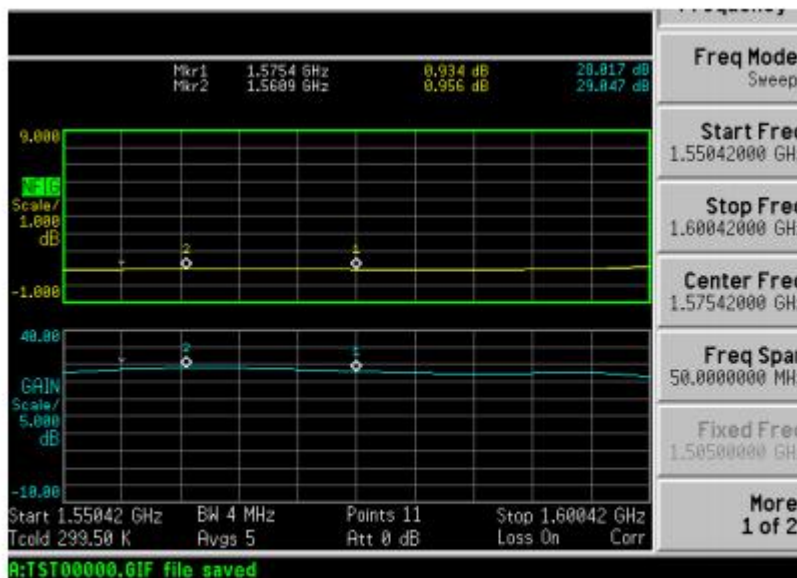

Noise Figure:N=0.95