

ACGRAT101-HF Thru. ACGRAT105-HF

Glass Passivated Type

Reverse Voltage: 200 to 1000 Volts

Forward Current: 1.0 Amp

RoHS Device

Halogen Free



Features

- Glass passivated cavity-free junction.
- Lead less chip form, no lead damage.
- Low forward voltage drop.
- Plastic package has UL 94V-0.
- Comply with AEC-Q101

Mechanical data

- Case: Packed with FRP substrate and epoxy underfilled.
- Terminals: Pure Tin plated (Lead-Free), solderable per MIL-STD-750, method 2026.
- Polarity: Cathode Band, Laser marking.
- Weight: 0.02 grams(approx).

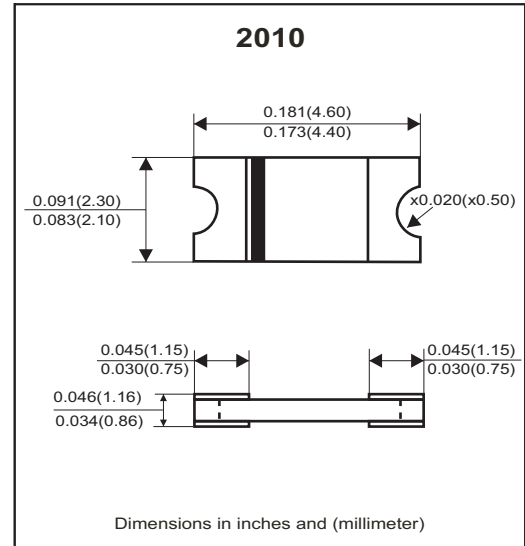

Circuit Diagram



Absolute Maximum Ratings (at Ta=25°C unless otherwise noted)

Parameter	Symbol	ACGRAT 101-HF	ACGRAT 102-HF	ACGRAT 103-HF	ACGRAT 104-HF	ACGRAT 105-HF	Units
Repetitive peak reverse voltage	V _{RRM}	200	400	600	800	1000	V
Peak forward surge current, 8.3ms single half sine-wave superimposed on rate load (JEDEC method)	I _{FSM}	30					A
Average forward current	I _{F(AV)}	1.0					A
Operating junction temperature	T _J	-65 to +175					°C
Storage temperature	T _{STG}	-65 to +175					°C

Electrical Characteristics (at TA=25°C unless otherwise noted)

Parameter	Conditions	Symbol	MIN.	TYP.	MAX.	Unit
Forward voltage	I _F = 1.0A	V _F	-	0.95	1	V
Repetitive peak reverse current	V _R =Max. V _{RRM} , TA=25°C	I _{RRM}	-	0.10	5	uA
Junction capacitance	V _R =4V, f=1.0MHz	C _J	-	8	-	pF
Thermal Resistance	Junction to ambient (Note)	R _{θJA}	-	65	-	°C/W
	Junction to lead (Note)	R _{θJL}	-	15	-	

Notes: Thermal resistance from junction to ambient and from junction to lead P.C.B. mounted on 0.2×0.2”(5.0*5.0mm) copper pad areas.

RATING AND CHARACTERISTIC CURVES (ACGRAT101-HF thru. ACGRAT105-HF)

FIG.1 - FORWARD CURRENT DERATING CURVE

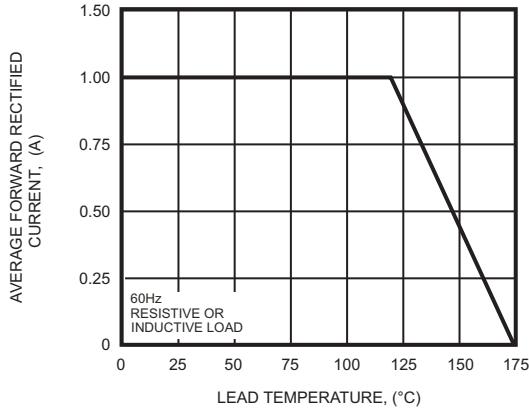

FIG.2 - MAXIMUM NON-REPETITIVE PEAK FORWARD SURGE CURRENT

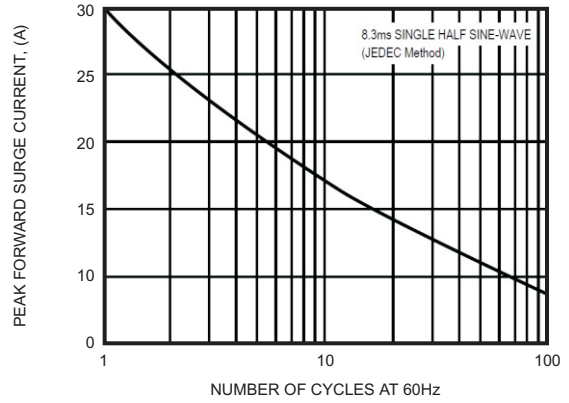

FIG.3 - TYPICAL INSTANTANEOUS FORWARD CHARACTERISTICS

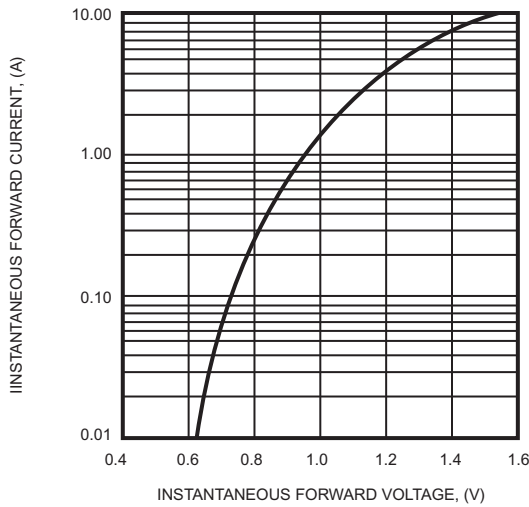

FIG.4 - TYPICAL REVERSE CHARACTERISTICS

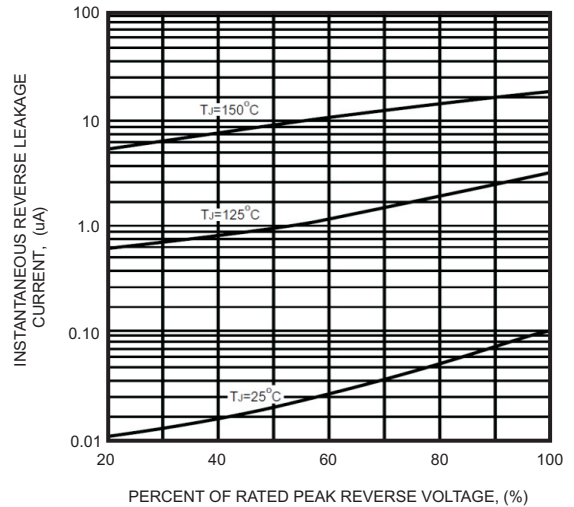
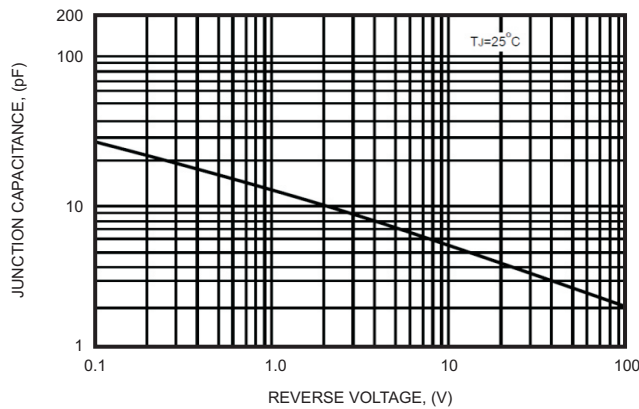
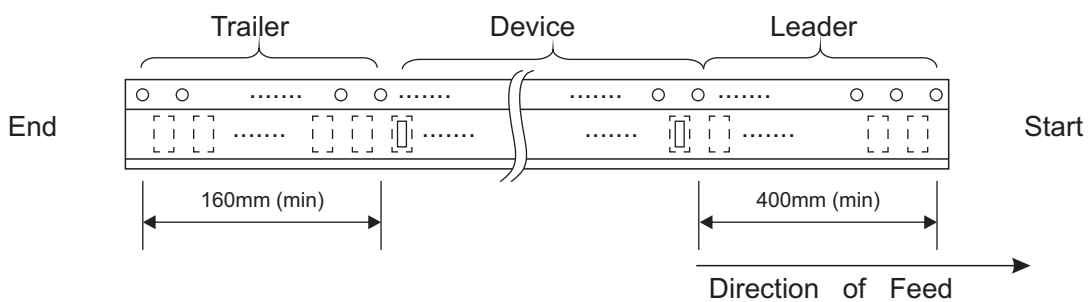
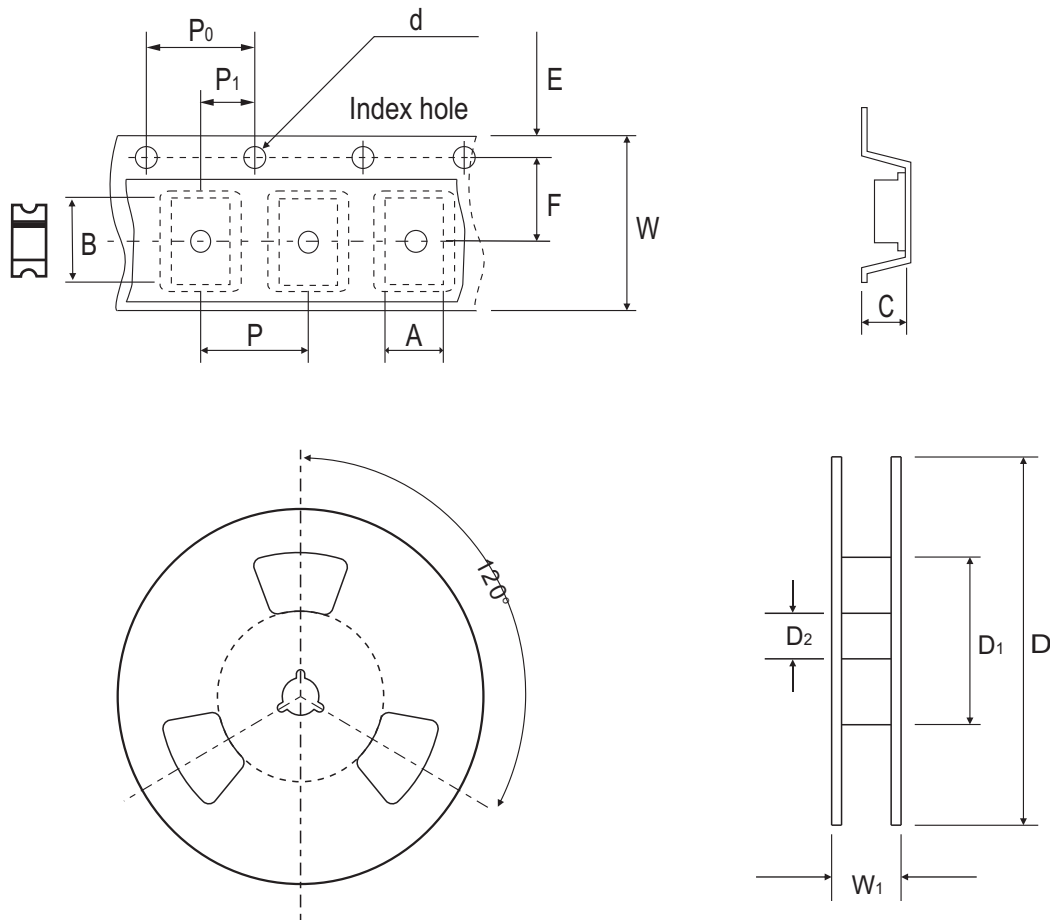

FIG.5 - TYPICAL JUNCTION CAPACITANCE



Reel Taping Specification



2010	SYMBOL	A	B	C	d	D	D ₁	D ₂
	(mm)	4.75 ± 0.10	2.45 ± 0.10	1.30 ± 0.10	1.50 ± 0.10	178.00 ± 2.00	50.00 MIN.	13.00 ± 0.50
	(inch)	0.187 ± 0.004	0.096 ± 0.004	0.051 ± 0.004	0.059 ± 0.004	7.008 ± 0.079	1.969 MIN.	0.512 ± 0.020

2010	SYMBOL	E	F	P	P ₀	P ₁	W	W ₁
	(mm)	1.75 ± 0.10	5.50 ± 0.05	4.00 ± 0.10	4.00 ± 0.10	2.00 ± 0.10	12.00 ± 0.30	18.70 MAX.
	(inch)	0.069 ± 0.004	0.217 ± 0.002	0.157 ± 0.004	0.157 ± 0.004	0.079 ± 0.004	0.472 ± 0.012	0.736 MAX.

Marking Code

Part Number	Marking Code
ACGRAT101-HF	10D
ACGRAT102-HF	10G
ACGRAT103-HF	10J
ACGRAT104-HF	10K
ACGRAT105-HF	10M



XXX = Product type marking code

Suggested PAD Layout

SIZE	2010	
	(mm)	(inch)
A	1.47MIN.	0.058MIN.
B	1.27MIN.	0.050MIN.
C	2.60MAX.	0.102MAX.
D	5.14REF.	0.202 REF.

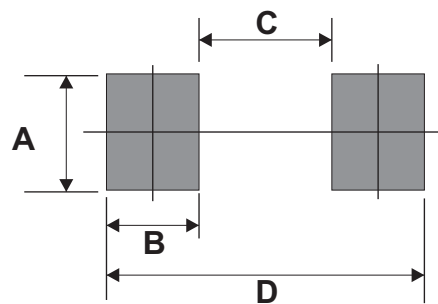

Standard Packaging

Case Type	REEL PACK	
	REEL (pcs)	Reel Size (inch)
2010	3,000	7