

### General Description

The ICS844201I-45 is a PCI Express<sup>™</sup> Clock Generator. The ICS844201I-45 can synthesize 100MHz or 125MHz reference clock frequencies with a 25MHz crystal. The ICS844201I-45 has excellent phase jitter performance and is packaged in a small 16-pin VFQFN, making it ideal for use in systems with limited board space.

### Features

- One differential LVDS output pair
- Crystal oscillator interface designed for 18pF, 25MHz parallel resonant crystal
- VCO range: 490MHz – 680MHz
- RMS phase jitter at 100MHz (12kHz – 20MHz): 0.792ps (typical)
- RMS phase jitter at 125MHz (12kHz – 20MHz): 0.773ps (typical)
- Full 3.3V output supply mode
- PCI Express (2.5Gb/s) and Gen 2 (5Gb/S) jitter compliant
- -40°C to 85°C ambient operating temperature
- Lead-free (RoHS 6) packaging

### Frequency Table

Inputs					Output Frequency Range (MHz)
Crystal Frequency (MHz)	M	FSEL	N	Multiplication Value M/N	
25	20	1	4	5	125 (default)
25	20	0	5	4	100

### Block Diagram

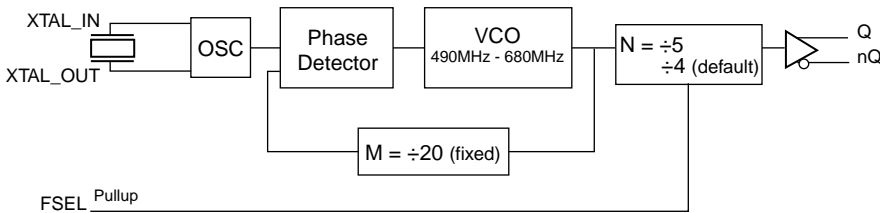

### Pin Assignment

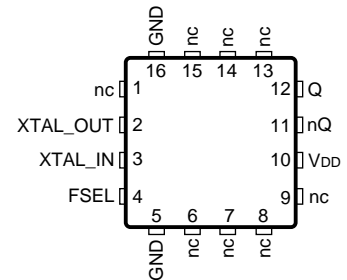

**ICS844201I-45**  
**16-Lead VFQFN**  
**Top View**

## Pin Descriptions and Characteristics

**Table 1. Pin Descriptions**

Number	Name	Type		Description
1, 6, 7, 8, 9, 13, 14, 15	nc	Unused		No connect.
2, 3	XTAL_OUT XTAL_IN	Input		Crystal oscillator interface. XTAL_IN is the input, XTAL_OUT is the output.
4	FSEL	Input	Pullup	Frequency select pin. LVCMOS/LVTTL interface levels.
5, 16	GND	Power		Power supply ground.
10	V <sub>DD</sub>	Power		Power supply pin.
11, 12	nQ, Q	Output		Differential output pair. LVDS interface levels.

NOTE: *Pullup* refers to internal input resistors. See Table 2, *Pin Characteristics*, for typical values.

**Table 2. Pin Characteristics**

Symbol	Parameter	Test Conditions	Minimum	Typical	Maximum	Units
C <sub>IN</sub>	Input Capacitance			4		pF
R <sub>PULLUP</sub>	Input Pullup Resistor			51		kΩ

## Absolute Maximum Ratings

NOTE: Stresses beyond those listed under *Absolute Maximum Ratings* may cause permanent damage to the device. These ratings are stress specifications only. Functional operation of the product at these conditions or any conditions beyond those listed in the *DC Characteristics* or *AC Characteristics* is not implied. Exposure to absolute maximum rating conditions for extended periods may affect product reliability.

Item	Rating
Supply Voltage, V <sub>DD</sub>	4.6V
Inputs, V <sub>I</sub> XTAL_IN Other Inputs	0V to V <sub>DD</sub> -0.5V to V <sub>DD</sub> + 0.5V
Outputs, I <sub>O</sub> Continuous Current Surge Current	10mA 15mA
Package Thermal Impedance, θ <sub>JA</sub>	74.9°C/W (0 mps)
Storage Temperature, T <sub>STG</sub>	-65°C to 150°C

## DC Electrical Characteristics

**Table 3A. Power Supply DC Characteristics,  $V_{DD} = 3.3V \pm 10\%$ ,  $T_A = -40^\circ\text{C}$  to  $85^\circ\text{C}$**

Symbol	Parameter	Test Conditions	Minimum	Typical	Maximum	Units
$V_{DD}$	Power Supply Voltage		2.97	3.3	3.63	V
$I_{DD}$	Power Supply Current				95	mA

**Table 3B. LVC MOS/LVTTL DC Characteristics,  $V_{DD} = 3.3V \pm 10\%$ ,  $T_A = -40^\circ\text{C}$  to  $85^\circ\text{C}$**

Symbol	Parameter	Test Conditions	Minimum	Typical	Maximum	Units
$V_{IH}$	Input High Voltage		2		$V_{DD} + 0.3$	V
$V_{IL}$	Input Low Voltage		-0.3		0.8	V
$I_{IH}$	Input High Current	$V_{DD} = V_{IN} = 3.63V$			5	$\mu\text{A}$
$I_{IL}$	Input Low Current	$V_{DD} = 3.63V, V_{IN} = 0V$	-150			$\mu\text{A}$

**Table 3C. LVDS DC Characteristics,  $V_{DD} = 3.3V \pm 10\%$ ,  $T_A = -40^\circ\text{C}$  to  $85^\circ\text{C}$**

Symbol	Parameter	Test Conditions	Minimum	Typical	Maximum	Units
$V_{OD}$	Differential Output Voltage		247		454	mV
$\Delta V_{OD}$	$V_{OD}$ Magnitude Change				50	mV
$V_{DIFF\_OUT}$	Peak-to-Peak Differential Output Voltage		494		908	mV
$V_{OS}$	Offset Voltage		1.3		1.63	V
$\Delta V_{OS}$	$V_{OS}$ Magnitude Change				50	mV

**Table 4. Crystal Characteristics**

Parameter	Test Conditions	Minimum	Typical	Maximum	Units
Mode of Oscillation		Fundamental			
Frequency		24.5	25	34	MHz
Equivalent Series Resistance (ESR)				50	$\Omega$
Shunt Capacitance				7	pF

## AC Electrical Characteristics

**Table 5. AC Characteristics,  $V_{DD} = 3.3V \pm 10\%$ ,  $T_A = -40^\circ C$  to  $85^\circ C$**

Symbol	Parameter	Test Conditions	Minimum	Typical	Maximum	Units
$f_{OUT}$	Output Frequency			125		MHz
				100		MHz
$f_{jit}(\emptyset)$	RMS Phase Jitter, Random; NOTE 1	125MHz, Integration Range: 12kHz – 20MHz		0.773		ps
		100MHz, Integration Range: 12kHz – 20MHz		0.792		ps
$t_j$	Phase Jitter Peak-to-Peak; NOTE 2	125MHz, (1.2MHz – 21.9MHz) 25MHz crystal input Evaluation Band: 0Hz - Nyquist (clock frequency/2)		12.51		ps
		100MHz, (1.2MHz – 21.9MHz) 25MHz crystal input Evaluation Band: 0Hz - Nyquist (clock frequency/2)		13.48		ps
$t_{REFCLK\_HF\_RMS}$	Phase Jitter RMS; NOTE 3	125MHz, (1.2MHz – 21.9MHz) 25MHz crystal input High Band: 1.5MHz - Nyquist (clock frequency/2)		1.13		ps
		100MHz, (1.2MHz – 21.9MHz) 25MHz crystal input High Band: 1.5MHz - Nyquist (clock frequency/2)		1.25		ps
$t_{REFCLK\_LF\_RMS}$	Phase Jitter RMS; NOTE 3	125MHz, (1.2MHz – 21.9MHz) 25MHz crystal input Low Band: 10kHz - 1.5MHz		0.32		ps
		100MHz, (1.2MHz – 21.9MHz) 25MHz crystal input Low Band: 10kHz - 1.5MHz		0.33		ps
$t_R / t_F$	Output Rise/Fall Time	20% to 80%	250		450	ps
odc	Output Duty Cycle	$f_{OUT} = 125MHz$	48		52	%
		$f_{OUT} = 100MHz$	46		54	%

NOTE: Electrical parameters are guaranteed over the specified ambient operating temperature range, which is established when the device is mounted in a test socket with maintained transverse airflow greater than 500 lfm. The device will meet specifications after thermal equilibrium has been reached under these conditions.

NOTE: Characterized using a 25MHz crystal.

NOTE 1: Refer to Phase Noise Plots.

NOTE 2: Peak-to-Peak jitter after applying system transfer function for the Common Clock Architecture. Maximum limit for PCI Express Gen 1 is 86ps peak-to-peak for a sample size of  $10^6$  clock periods. See IDT Application Note *PCI Express Reference Clock Requirements* and also the PCI Express Application section of this datasheet which show each individual transfer function and the overall composite transfer function.

NOTE 3: RMS jitter after applying the two evaluation bands to the two transfer functions defined in the Common Clock Architecture and reporting the worst case results for each evaluation band. Maximum limit for PCI Express Generation 2 is 3.1ps rms for  $t_{REFCLK\_HF\_RMS}$  (High Band) and 3.0 ps RMS for  $t_{REFCLK\_LF\_RMS}$  (Low Band). See IDT Application Note *PCI Express Reference Clock Requirements* and also the PCI Express Application section of this datasheet which show each individual transfer function and the overall composite transfer function.

### Typical Phase Noise at 100MHz

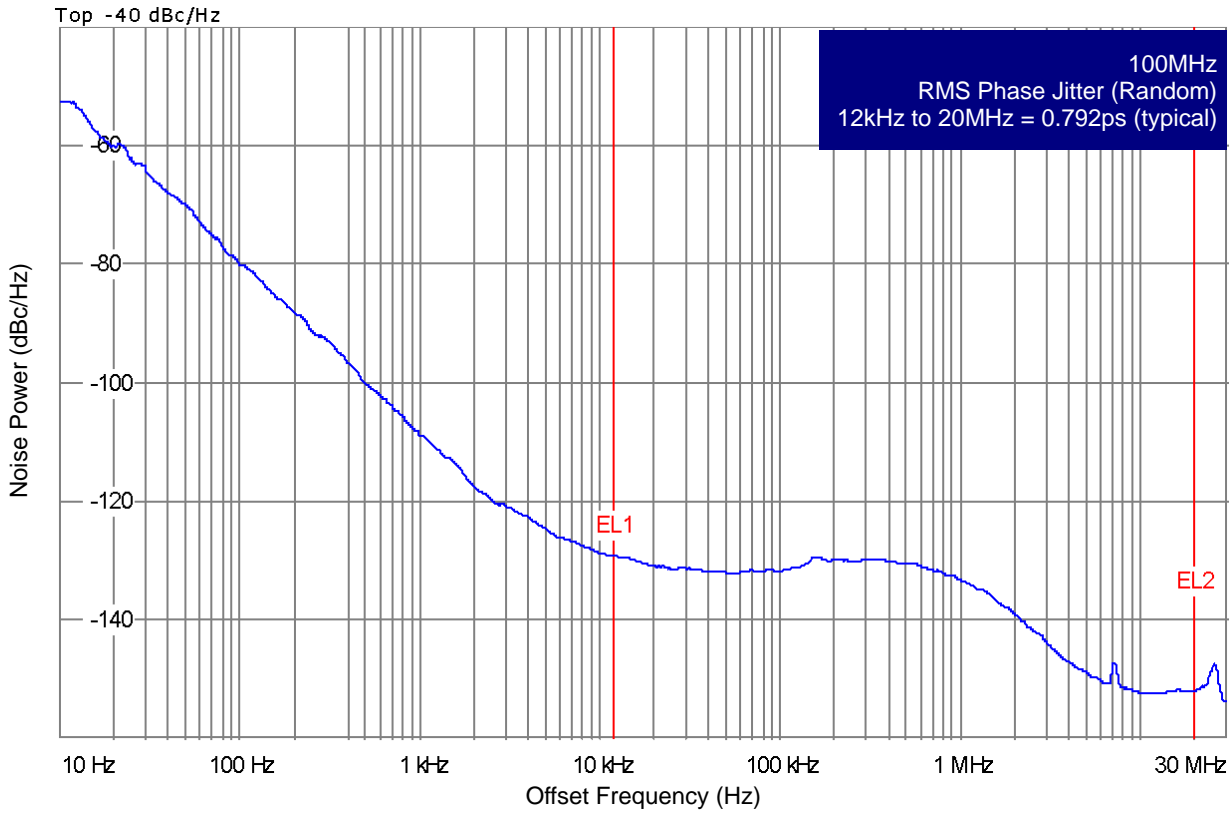

### Typical Phase Noise at 125MHz

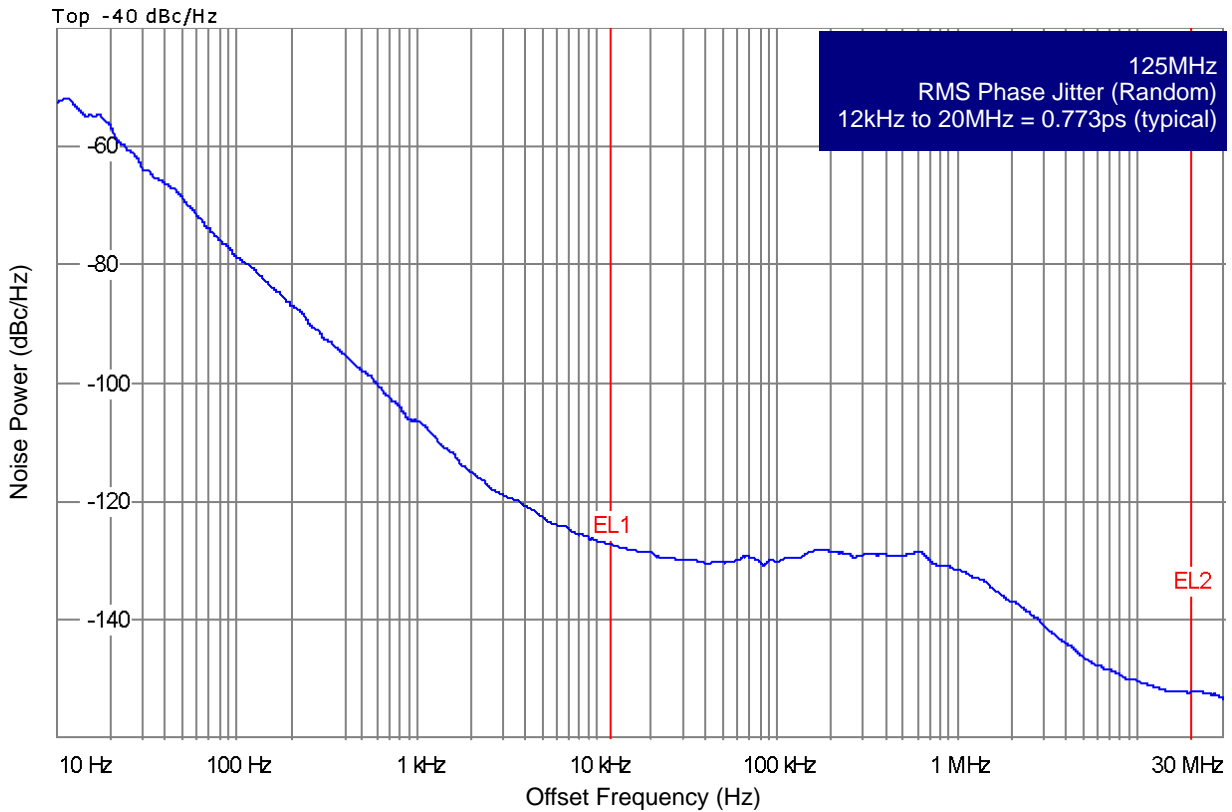

### Parameter Measurement Information

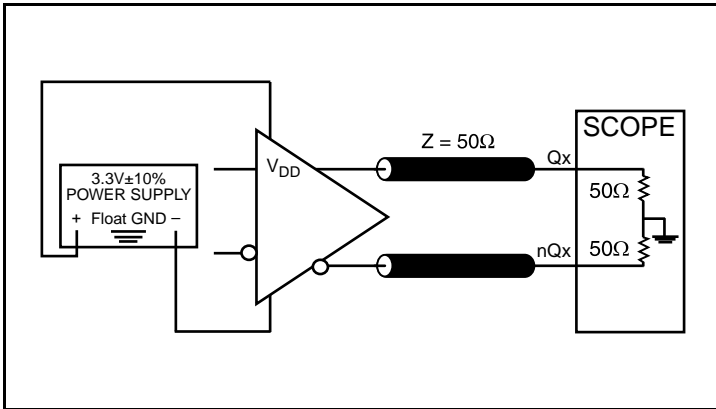

3.3V LVDS Output Load AC Test Circuit

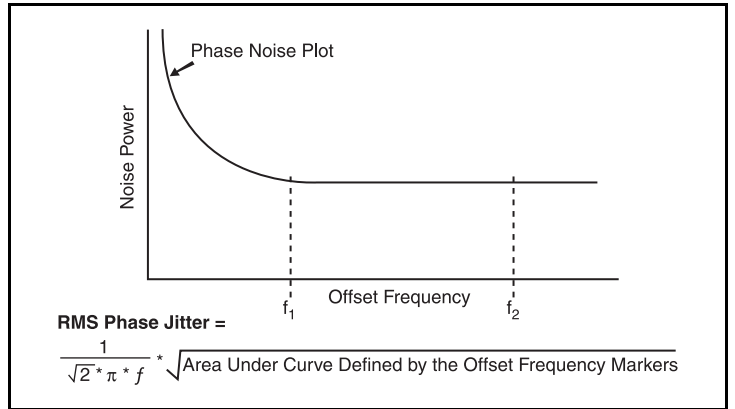

RMS Phase Jitter

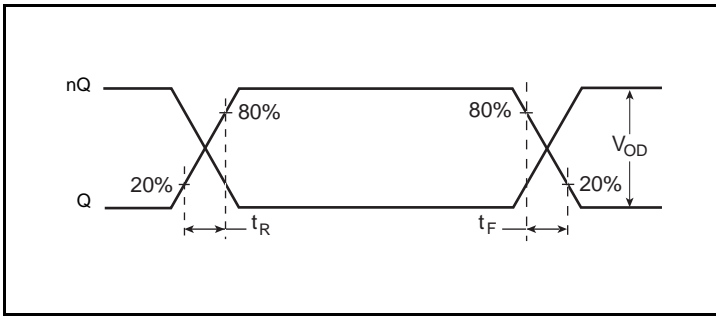

Output Rise/Fall Time

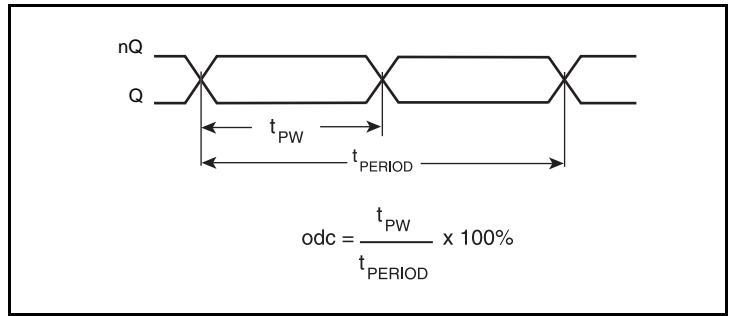

Output Duty Cycle/Pulse Width/Period

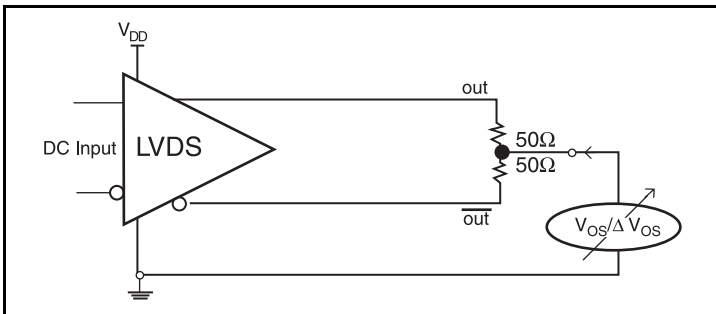

Offset Voltage Setup

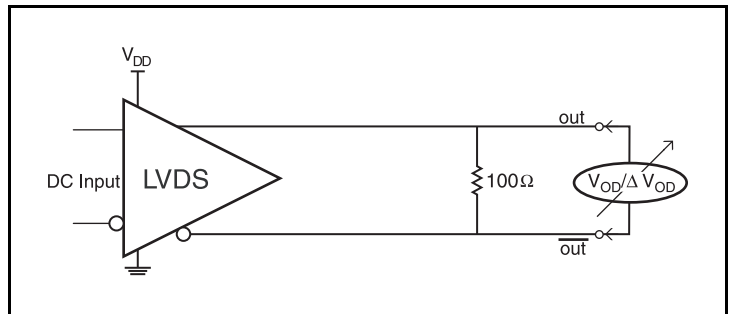

Differential Output Voltage Setup

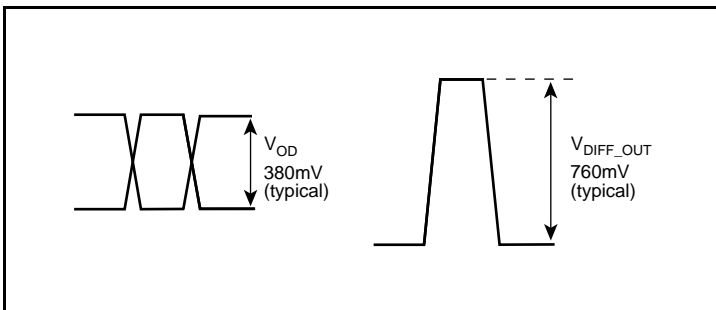

Differential Output Voltage

## Application Information

### Crystal Input Interface

The ICS844201I-45 has been characterized with 18pF parallel resonant crystals. The capacitor values, C1 and C2, shown in *Figure 1* below were determined using a 25MHz, 18pF parallel resonant crystal and were chosen to minimize the ppm error. The optimum C1 and C2 values can be slightly adjusted for different board layouts.

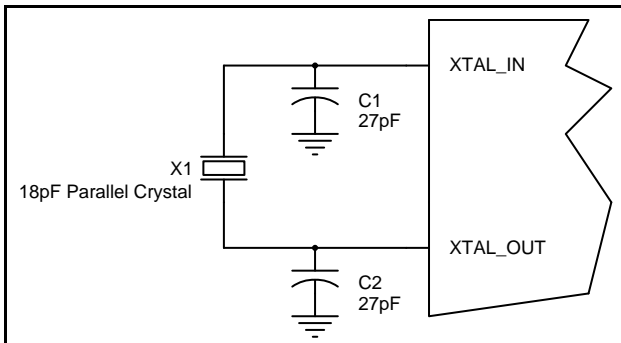

**Figure 1. Crystal Input Interface**

## Overdriving the XTAL Interface

The XTAL\_IN input can be overdriven by an LVCMOS driver or by one side of a differential driver through an AC coupling capacitor. The XTAL\_OUT pin can be left floating. The amplitude of the input signal should be between 500mV and 1.8V and the slew rate should not be less than 0.2V/ns. For 3.3V LVCMOS inputs, the amplitude must be reduced from full swing to at least half the swing in order to prevent signal interference with the power rail and to reduce internal noise. *Figure 2A* shows an example of the interface diagram for a high speed 3.3V LVCMOS driver. This configuration requires that the sum of the output impedance of the driver ( $R_o$ ) and the series resistance ( $R_s$ ) equals the transmission line impedance. In addition, matched termination at the crystal input will attenuate the signal in half. This

can be done in one of two ways. First,  $R_1$  and  $R_2$  in parallel should equal the transmission line impedance. For most 50Ω applications,  $R_1$  and  $R_2$  can be 100Ω. This can also be accomplished by removing  $R_1$  and changing  $R_2$  to 50Ω. The values of the resistors can be increased to reduce the loading for a slower and weaker LVCMOS driver. *Figure 2B* shows an example of the interface diagram for an LVPECL driver. This is a standard LVPECL termination with one side of the driver feeding the XTAL\_IN input. It is recommended that all components in the schematics be placed in the layout. Though some components might not be used, they can be utilized for debugging purposes. The datasheet specifications are characterized and guaranteed by using a quartz crystal as the input.

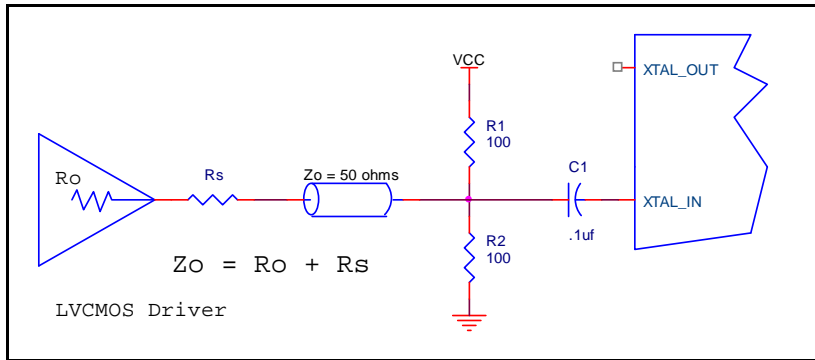

Figure 2A. General Diagram for LVCMOS Driver to XTAL Input Interface

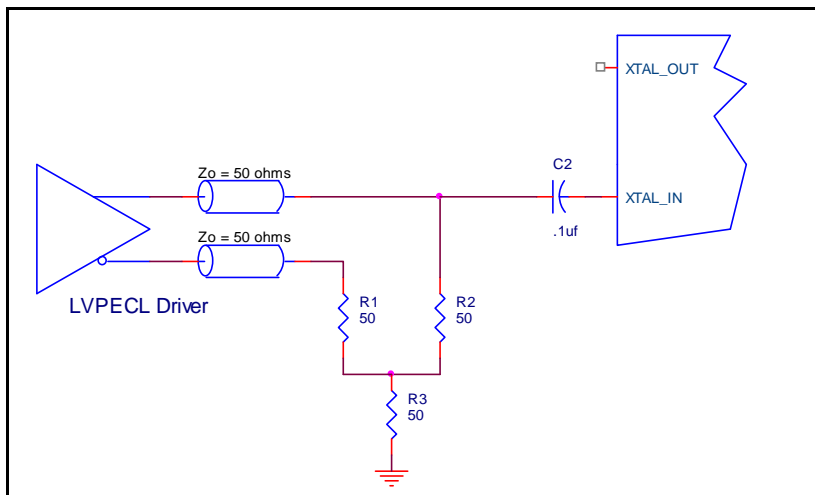

Figure 2B. General Diagram for LVPECL Driver to XTAL Input Interface



## LVDS Driver Termination

For a general LVDS interface, the recommended value for the termination impedance ( $Z_T$ ) is between  $90\Omega$  and  $132\Omega$ . The actual value should be selected to match the differential impedance ( $Z_0$ ) of your transmission line. A typical point-to-point LVDS design uses a  $100\Omega$  parallel resistor at the receiver and a  $100\Omega$  differential transmission-line environment. In order to avoid any transmission-line reflection issues, the components should be surface mounted and must be placed as close to the receiver as possible. IDT offers a full line of LVDS compliant devices with two types of output structures: current source and voltage source. The

standard termination schematic as shown in *Figure 3A* can be used with either type of output structure. *Figure 3B*, which can also be used with both output types, is an optional termination with center tap capacitance to help filter common mode noise. The capacitor value should be approximately  $50\text{pF}$ . If using a non-standard termination, it is recommended to contact IDT and confirm if the output structure is current source or voltage source type. In addition, since these outputs are LVDS compatible, the input receiver's amplitude and common-mode input range should be verified for compatibility with the output.

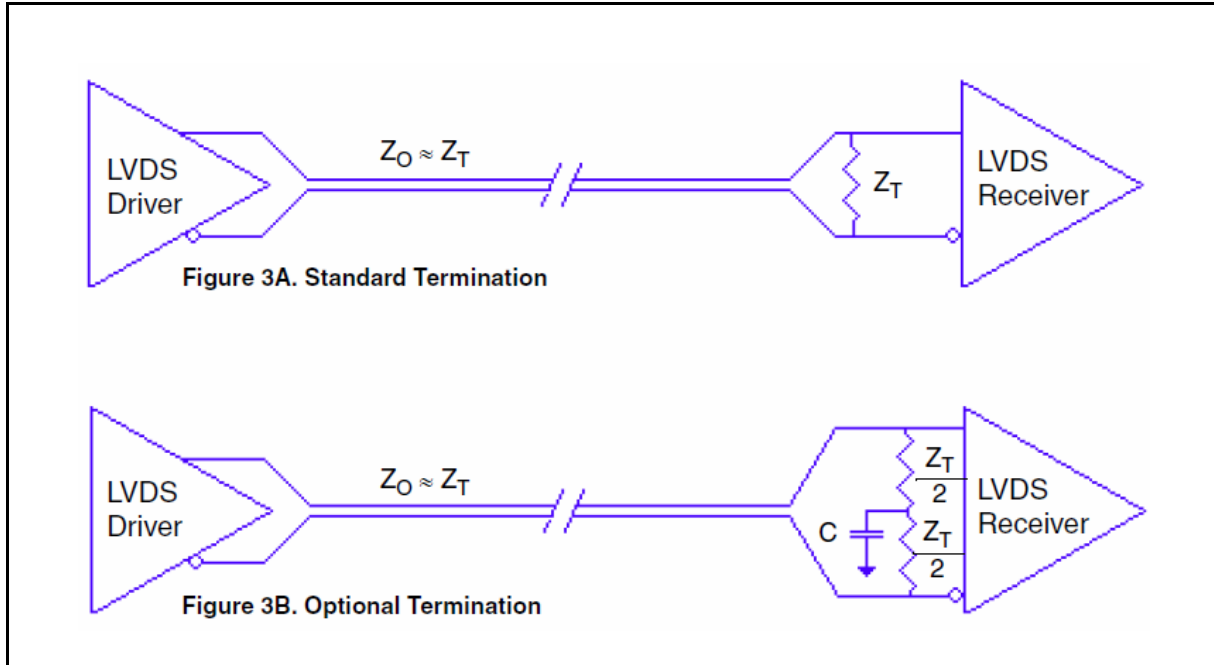

### LVDS Termination

### PCI Express Application Note

PCI Express jitter analysis methodology models the system response to reference clock jitter. The block diagram below shows the most frequently used *Common Clock Architecture* in which a copy of the reference clock is provided to both ends of the PCI Express Link.

In the jitter analysis, the transmit (Tx) and receive (Rx) serdes PLLs are modeled as well as the phase interpolator in the receiver. These transfer functions are called H1, H2, and H3 respectively. The overall system transfer function at the receiver is:

$$H_t(s) = H_3(s) \times [H_1(s) - H_2(s)]$$

The jitter spectrum seen by the receiver is the result of applying this system transfer function to the clock spectrum X(s) and is:

$$Y(s) = X(s) \times H_3(s) \times [H_1(s) - H_2(s)]$$

In order to generate time domain jitter numbers, an inverse Fourier Transform is performed on X(s)\*H3(s) \* [H1(s) - H2(s)].

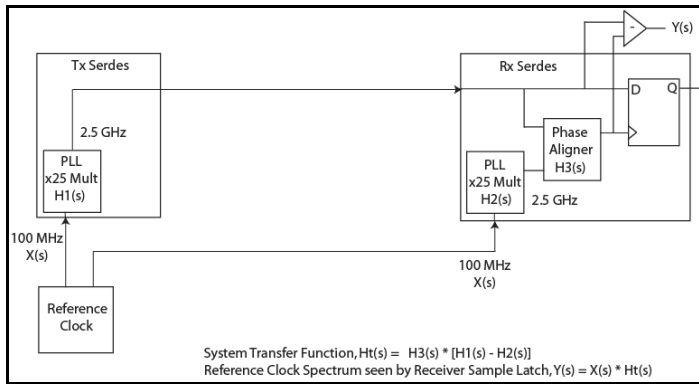

#### PCI Express Common Clock Architecture

For **PCI Express Gen 1**, one transfer function is defined and the evaluation is performed over the entire spectrum: DC to Nyquist (e.g for a 100MHz reference clock: 0Hz – 50MHz) and the jitter result is reported in peak-peak.

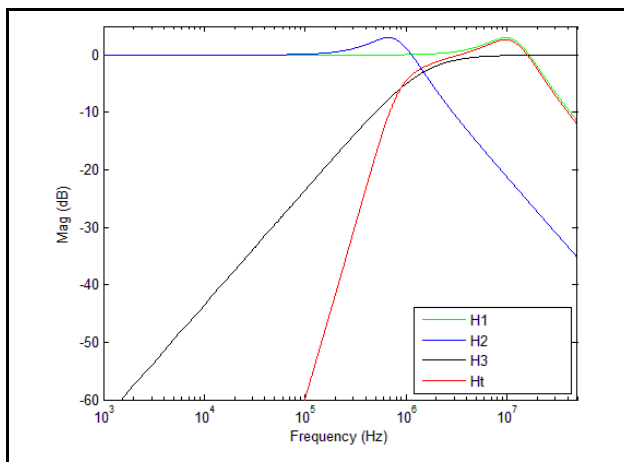

#### PCI Gen 1 Magnitude of Transfer Function

For **PCI Express Gen 2**, two transfer functions are defined with 2 evaluation ranges and the final jitter number is reported in rms. The two evaluation ranges for PCI Express Gen 2 are 10kHz – 1.5MHz (Low Band) and 1.5MHz – Nyquist (High Band). The plots show the individual transfer functions as well as the overall transfer function Ht.

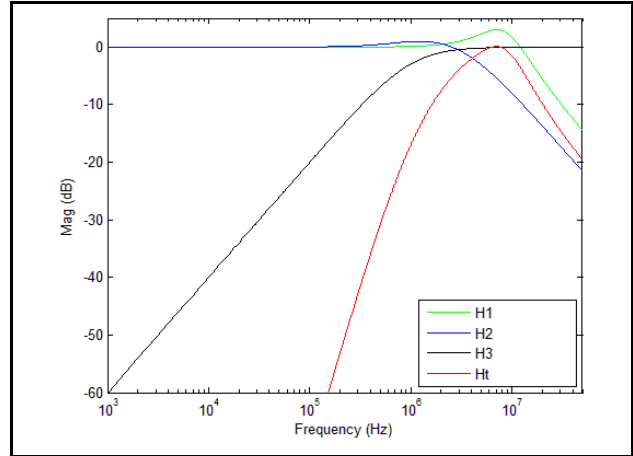

#### PCIe Gen 2A Magnitude of Transfer Function

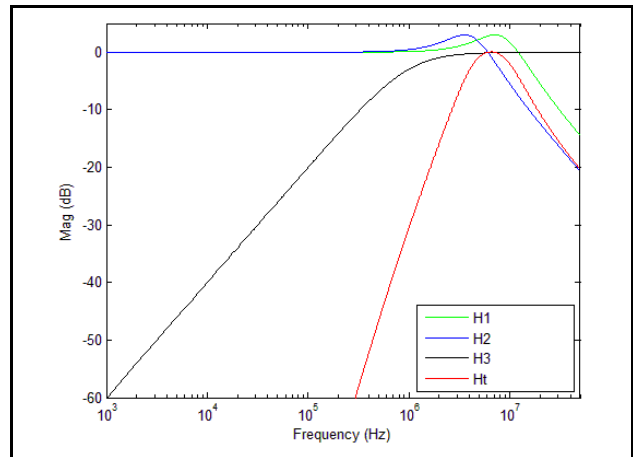

#### PCIe Gen 2B Magnitude of Transfer Function

For **PCI Express Gen 3**, one transfer function is defined and the evaluation is performed over the entire spectrum. The transfer function parameters are different from Gen 1 and the jitter result is reported in RMS.

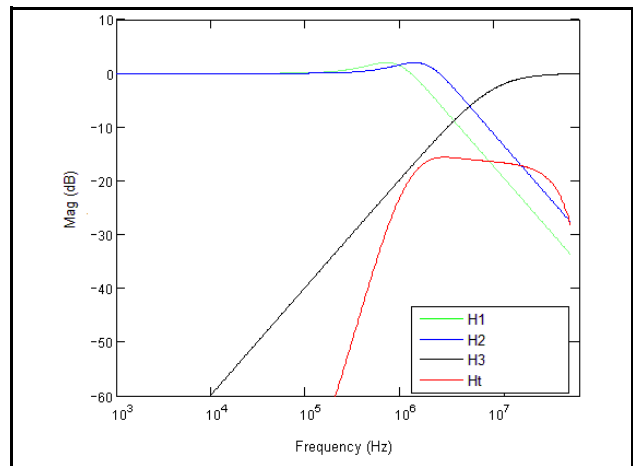

#### PCIe Gen 3 Magnitude of Transfer Function

For a more thorough overview of PCI Express jitter analysis methodology, please refer to IDT Application Note *PCI Express Reference Clock Requirements*.

### Schematic Example

Figure 4 shows an example of ICS844201I-45 application schematic. In this example, the device is operated at  $V_{DD} = 3.3V$ . The 18pF parallel resonant 25MHz crystal is used. The  $C1 = 27pF$  and  $C2 = 27pF$  are recommended for frequency accuracy. For different board

layouts, the  $C1$  and  $C2$  may be slightly adjusted for optimizing frequency accuracy. Two examples of LVDS for receiver without built-in termination are shown in this schematic.

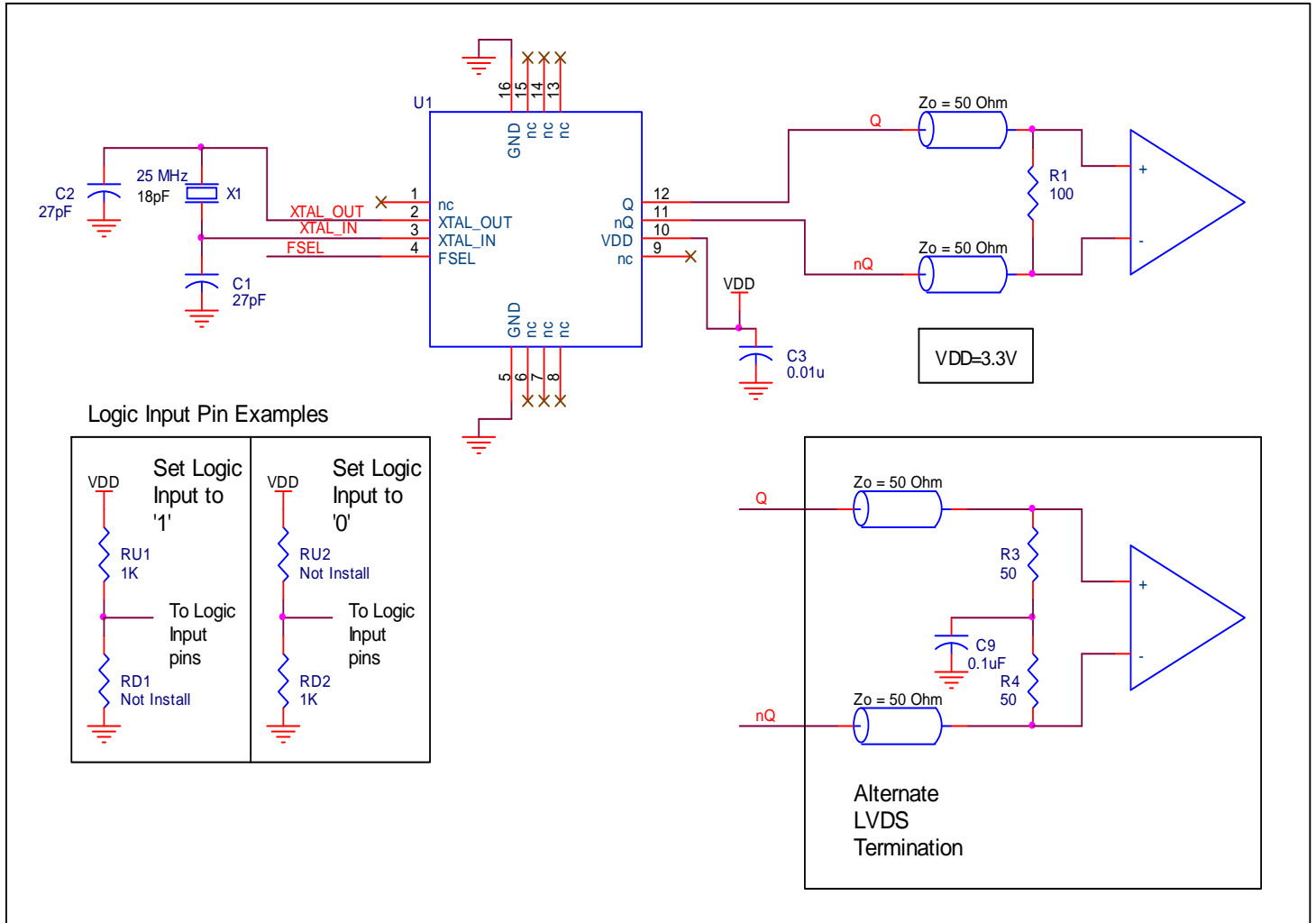

Figure 4. ICS844201I-45 Schematic Example

## Power Considerations

This section provides information on power dissipation and junction temperature for the ICS844201I-45. Equations and example calculations are also provided.

### 1. Power Dissipation.

The total power dissipation for the ICS844201I-45 is the sum of the core power plus the power dissipation in the load(s). The following is the power dissipation for  $V_{DD} = 3.3V + 10\% = 3.63V$ , which gives worst case results.

- Power (core)<sub>MAX</sub> =  $V_{DD\_MAX} * I_{DD\_MAX} = 3.63V * 95mA = \mathbf{344.85mW}$

### 2. Junction Temperature.

Junction temperature,  $T_j$ , is the temperature at the junction of the bond wire and bond pad, and directly affects the reliability of the device. The maximum recommended junction temperature is 125°C. Limiting the internal transistor junction temperature,  $T_j$ , to 125°C ensures that the bond wire and bond pad temperature remains below 125°C.

The equation for  $T_j$  is as follows:  $T_j = \theta_{JA} * Pd\_total + T_A$

$T_j$  = Junction Temperature

$\theta_{JA}$  = Junction-to-Ambient Thermal Resistance

$Pd\_total$  = Total Device Power Dissipation (example calculation is in section 1 above)

$T_A$  = Ambient Temperature

In order to calculate junction temperature, the appropriate junction-to-ambient thermal resistance  $\theta_{JA}$  must be used. Assuming no air flow and a multi-layer board, the appropriate value is 74.9°C/W per Table 6 below.

Therefore,  $T_j$  for an ambient temperature of 85°C with all outputs switching is:

$$85^\circ\text{C} + 0.345\text{W} * 74.9^\circ\text{C/W} = 110.8^\circ\text{C}. \text{ This is below the limit of } 125^\circ\text{C}.$$

This calculation is only an example.  $T_j$  will obviously vary depending on the number of loaded outputs, supply voltage, air flow and the type of board (multi-layer).

**Table 6. Thermal Resistance  $\theta_{JA}$  for 16 Lead VFQFN, Forced Convection**

$\theta_{JA}$ vs. Air Flow			
Meters per Second	0	1	2.5
Multi-Layer PCB, JEDEC Standard Test Boards	74.9°C/W	65.5°C/W	58.8°C/W

## Reliability Information

Table 7.  $\theta_{JA}$  vs. Air Flow Table for a 16 Lead VFQFN

$\theta_{JA}$ vs. Air Flow			
Meters per Second	0	1	2.5
Multi-Layer PCB, JEDEC Standard Test Boards	74.9°C/W	65.5°C/W	58.8°C/W

## Transistor Count

The transistor count for ICS844201I-45 is: 1986

# Package Outline Drawings (Sheet 1)

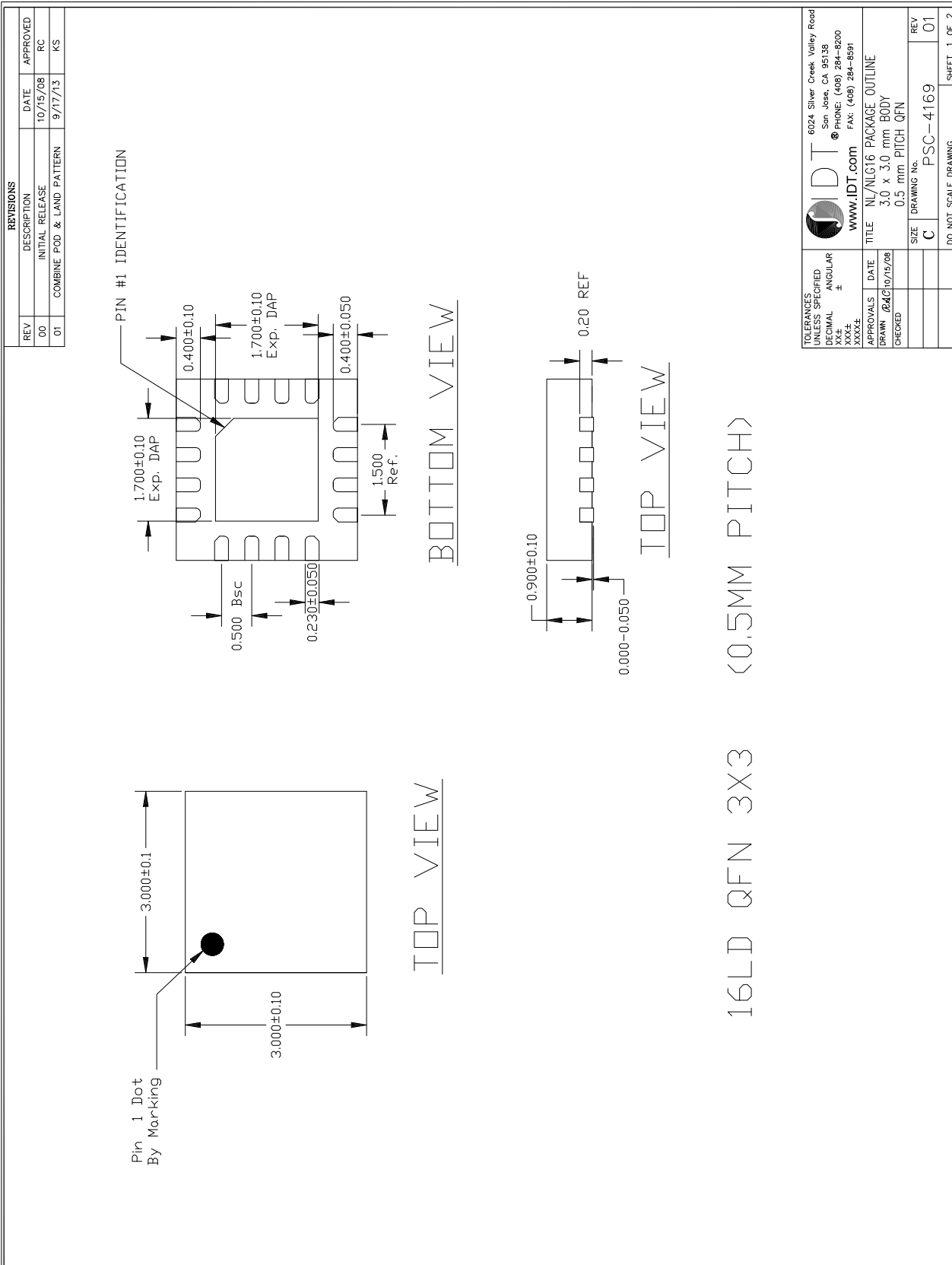

Package Outline Drawings (Sheet 2)

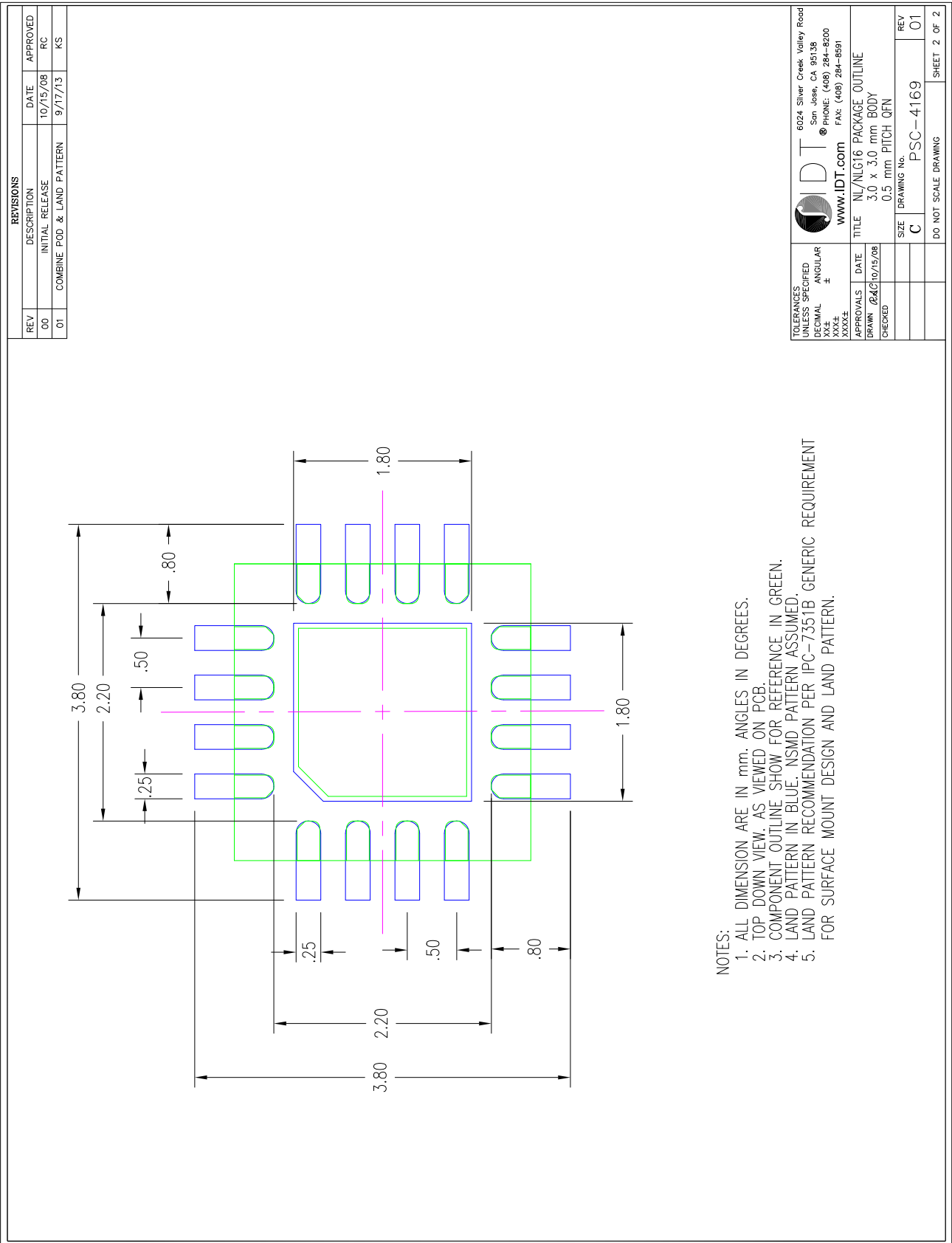

## Ordering Information

Table 9. Ordering Information

Part/Order Number	Marking	Package	Shipping Packaging	Temperature
844201BKI-45LF	B15L	"Lead-Free" 16 Lead VFQFN	Tube	-40°C to 85°C
844201BKI-45LFT	B15L	"Lead-Free" 16 Lead VFQFN	Tape & Reel	-40°C to 85°C

## Revision History Sheet

Rev	Table	Page	Description of Change	Date
A	-	-	Initial release.	10/07/2013
B	-	11/12	Updated the package outline drawings.	5/27/2017



Corporate Headquarters  
6024 Silver Creek Valley Road  
San Jose, CA 95138 USA  
[www.IDT.com](http://www.IDT.com)

Sales  
1-800-345-7015 or 408-284-8200  
Fax: 408-284-2775  
[www.IDT.com/go/sales](http://www.IDT.com/go/sales)

Tech Support  
[www.IDT.com/go/support](http://www.IDT.com/go/support)

DISCLAIMER Integrated Device Technology, Inc. (IDT) and its affiliated companies (herein referred to as "IDT") reserve the right to modify the products and/or specifications described herein at any time, without notice, at IDT's sole discretion. Performance specifications and operating parameters of the described products are determined in an independent state and are not guaranteed to perform the same way when installed in customer products. The information contained herein is provided without representation or warranty of any kind, whether express or implied, including, but not limited to, the suitability of IDT's products for any particular purpose, an implied warranty of merchantability, or non-infringement of the intellectual property rights of others. This document is presented only as a guide and does not convey any license under intellectual property rights of IDT or any third parties.

IDT's products are not intended for use in applications involving extreme environmental conditions or in life support systems or similar devices where the failure or malfunction of an IDT product can be reasonably expected to significantly affect the health or safety of users. Anyone using an IDT product in such a manner does so at their own risk, absent an express, written agreement by IDT.

Integrated Device Technology, IDT and the IDT logo are trademarks or registered trademarks of IDT and its subsidiaries in the United States and other countries. Other trademarks used herein are the property of IDT or their respective third party owners. For datasheet type definitions and a glossary of common terms, visit [www.idt.com/go/glossary](http://www.idt.com/go/glossary). Integrated Device Technology, Inc.. All rights reserved.