

WHITE CODING  
P/N 0988221040

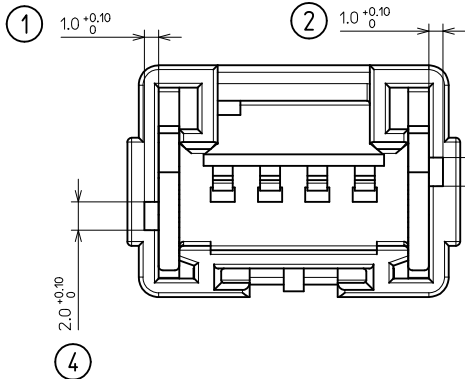

BLACK CODING  
P/N 0988221041

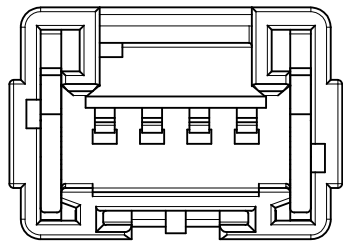

GREEN CODING  
P/N 0988221045

CODING 4:1

HANDLING AREA

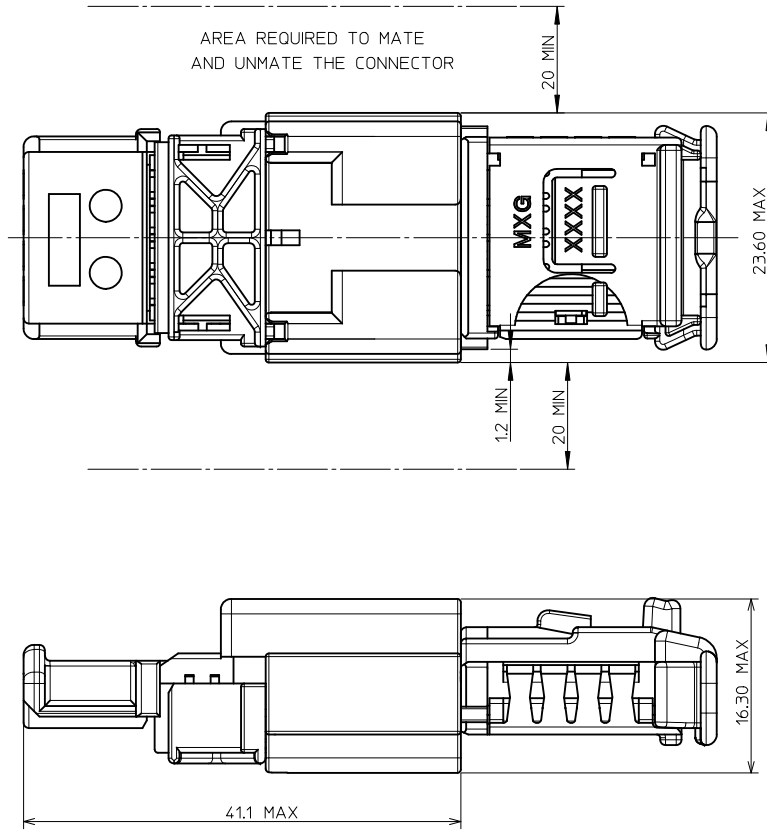

NOTE : 1 - The using conditions are shown in the MOLEX specification n°AS-98821-001.

2 - Male terminal used : SICMA 3 1.5mm

3 - Male connector will mate with female connector P/N 098817104x

AREA REQUIRED WHEN THE CONNECTOR IS MATED

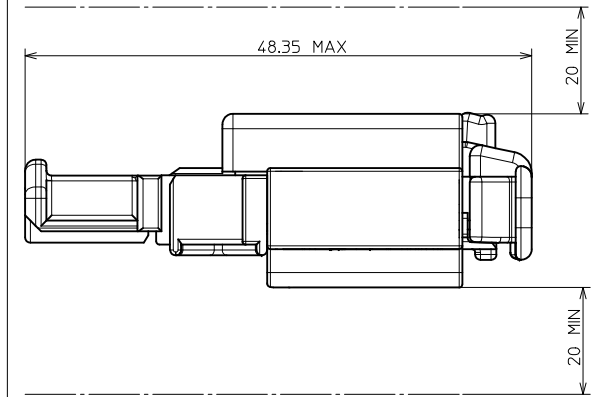

| <b>FIRST RELEASE</b><br>EC NO: G2012-0092<br>DRAWN: LPOUCHAUD 2009/03/02<br>CHKD: VJOLAS 2012/01/09<br>APPR: OPLESSIS 2012/01/31<br>REV: A | QUALITY SYMBOLS<br>▽=0<br>▽=0<br>▽=0 | GENERAL TOLERANCES (UNLESS SPECIFIED)<br><table border="1"> <thead> <tr> <th></th> <th>mm</th> <th>INCH</th> </tr> </thead> <tbody> <tr> <td>4 PLACES</td> <td>± ---</td> <td>± ---</td> </tr> <tr> <td>3 PLACES</td> <td>± ---</td> <td>± ---</td> </tr> <tr> <td>2 PLACES</td> <td>± ---</td> <td>± ---</td> </tr> <tr> <td>1 PLACE</td> <td>± 0.1</td> <td>± ---</td> </tr> </tbody> </table> |                       | mm                 | INCH                                                                                                                          | 4 PLACES | ± --- | ± --- | 3 PLACES | ± --- | ± --- | 2 PLACES | ± --- | ± --- | 1 PLACE | ± 0.1 | ± --- | DIMENSION STYLE<br><b>MM ONLY</b> | SCALE<br><b>3:1</b> | DESIGN UNITS<br><b>METRIC</b> | FIRST ANGLE PROJECTION |
|--------------------------------------------------------------------------------------------------------------------------------------------|--------------------------------------|--------------------------------------------------------------------------------------------------------------------------------------------------------------------------------------------------------------------------------------------------------------------------------------------------------------------------------------------------------------------------------------------------|-----------------------|--------------------|-------------------------------------------------------------------------------------------------------------------------------|----------|-------|-------|----------|-------|-------|----------|-------|-------|---------|-------|-------|-----------------------------------|---------------------|-------------------------------|------------------------|
|                                                                                                                                            |                                      | mm                                                                                                                                                                                                                                                                                                                                                                                               | INCH                  |                    |                                                                                                                               |          |       |       |          |       |       |          |       |       |         |       |       |                                   |                     |                               |                        |
|                                                                                                                                            | 4 PLACES                             | ± ---                                                                                                                                                                                                                                                                                                                                                                                            | ± ---                 |                    |                                                                                                                               |          |       |       |          |       |       |          |       |       |         |       |       |                                   |                     |                               |                        |
|                                                                                                                                            | 3 PLACES                             | ± ---                                                                                                                                                                                                                                                                                                                                                                                            | ± ---                 |                    |                                                                                                                               |          |       |       |          |       |       |          |       |       |         |       |       |                                   |                     |                               |                        |
| 2 PLACES                                                                                                                                   | ± ---                                | ± ---                                                                                                                                                                                                                                                                                                                                                                                            |                       |                    |                                                                                                                               |          |       |       |          |       |       |          |       |       |         |       |       |                                   |                     |                               |                        |
| 1 PLACE                                                                                                                                    | ± 0.1                                | ± ---                                                                                                                                                                                                                                                                                                                                                                                            |                       |                    |                                                                                                                               |          |       |       |          |       |       |          |       |       |         |       |       |                                   |                     |                               |                        |
|                                                                                                                                            |                                      |                                                                                                                                                                                                                                                                                                                                                                                                  | DRAWN BY<br>LPOUCHAUD | DATE<br>2009/03/02 | TITLE<br><b>NSCC PIN CONN 1.5 4KT</b>                                                                                         |          |       |       |          |       |       |          |       |       |         |       |       |                                   |                     |                               |                        |
|                                                                                                                                            |                                      |                                                                                                                                                                                                                                                                                                                                                                                                  | CHECKED BY<br>YIGEL   | DATE<br>2009/03/02 | APPROVED BY<br>OPLESSIS                                                                                                       |          |       |       |          |       |       |          |       |       |         |       |       |                                   |                     |                               |                        |
|                                                                                                                                            |                                      |                                                                                                                                                                                                                                                                                                                                                                                                  | DATE<br>2012/01/31    |                    | <b>MOLEX INCORPORATED</b><br>MATERIAL NO.<br><b>SEE SHEET 2</b>                                                               |          |       |       |          |       |       |          |       |       |         |       |       |                                   |                     |                               |                        |
|                                                                                                                                            |                                      |                                                                                                                                                                                                                                                                                                                                                                                                  |                       |                    | DOCUMENT NO.<br><b>SD-98822-005</b>                                                                                           |          |       |       |          |       |       |          |       |       |         |       |       |                                   |                     |                               |                        |
|                                                                                                                                            |                                      |                                                                                                                                                                                                                                                                                                                                                                                                  |                       |                    | SHEET NO.<br><b>1 OF 2</b>                                                                                                    |          |       |       |          |       |       |          |       |       |         |       |       |                                   |                     |                               |                        |
|                                                                                                                                            |                                      |                                                                                                                                                                                                                                                                                                                                                                                                  |                       |                    | THIS DRAWING CONTAINS INFORMATION THAT IS PROPRIETARY TO MOLEX INCORPORATED AND SHOULD NOT BE USED WITHOUT WRITTEN PERMISSION |          |       |       |          |       |       |          |       |       |         |       |       |                                   |                     |                               |                        |

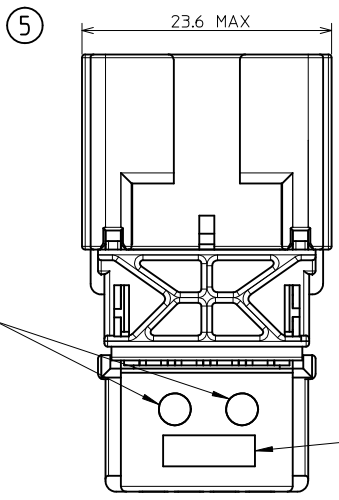

|                              |       |
|------------------------------|-------|
| 0988221045                   | GREEN |
| 0988221041                   | BLACK |
| 0988221040                   | WHITE |
| PART NUMBER<br>ASSEMBLY PART | COLOR |

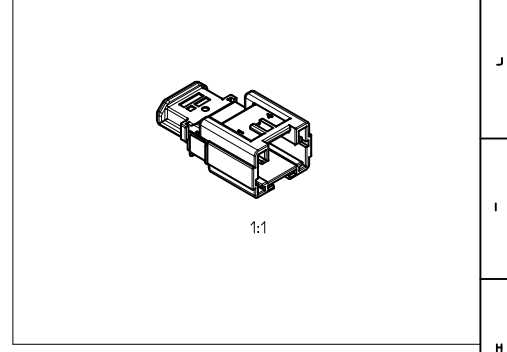

DATUM MONTH/YEAR

SUPPLIER ENGINEERING CONTROL ID

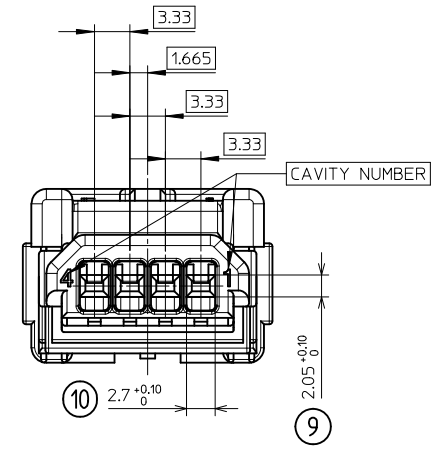
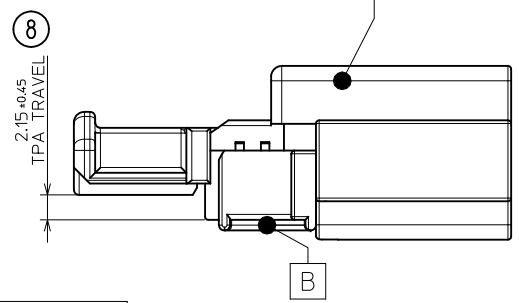
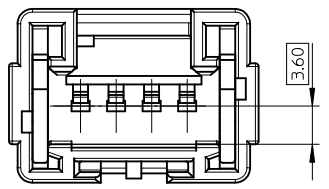
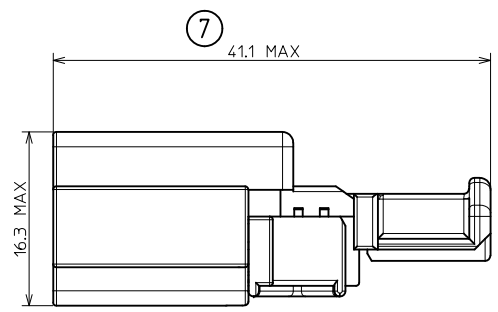

SUPPLIER PART NUMBER

PRINT NUMBER

RAW MATERIAL

BLACK CODING (P/N 0988221041) IS SHOWN.

SUPPLIER MODIFICATION LEVEL

CAVITY NUMBER

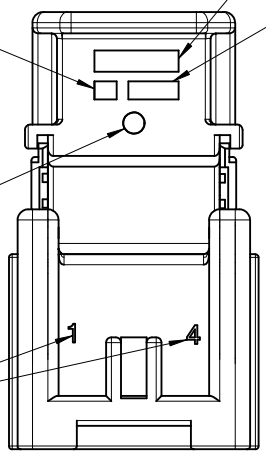

|                                                                                                                           |                                      |                                                                                                                                                         |                            |                                                                                                                               |                        |
|---------------------------------------------------------------------------------------------------------------------------|--------------------------------------|---------------------------------------------------------------------------------------------------------------------------------------------------------|----------------------------|-------------------------------------------------------------------------------------------------------------------------------|------------------------|
| B                                                                                                                         | SCC Pin Conn 1.5x0.8 TPA 4Ckt        | 0988220144                                                                                                                                              | Yellow                     | POLYAMIDE<br>>PA66-GF20<                                                                                                      | 5.370                  |
| A                                                                                                                         | SCC Pin Conn Unsealed 1.5x0.8 4Ckt   | 0988220045                                                                                                                                              | Green                      | POLYESTER<br>>PBT<                                                                                                            |                        |
|                                                                                                                           |                                      | 0988220041                                                                                                                                              | Black                      |                                                                                                                               |                        |
|                                                                                                                           |                                      | 0988220040                                                                                                                                              | White                      |                                                                                                                               |                        |
| Item                                                                                                                      | Description                          | Part-number                                                                                                                                             | Color                      | Raw Material                                                                                                                  | Weight effective (g)   |
| FIRST RELEASE<br>EC NO: G2012-0092<br>DRAWN: LPOUCHAUD 2009/03/02<br>CHKD: VJOUAS 2012/01/31<br>APPR: OPLESSIS 2012/01/31 | QUALITY SYMBOLS<br>▽=0<br>▽=0<br>▽=0 | GENERAL TOLERANCES (UNLESS SPECIFIED)<br>mm INCH<br>4 PLACES ±--- ±---<br>3 PLACES ±--- ±---<br>2 PLACES ±--- ±---<br>1 PLACE ±0.1 ±---<br>ANGULAR ± 1° | DIMENSION STYLE<br>MM ONLY | SCALE<br>3:1                                                                                                                  | DESIGN UNITS<br>METRIC |
|                                                                                                                           |                                      |                                                                                                                                                         |                            |                                                                                                                               | FIRST ANGLE PROJECTION |
|                                                                                                                           |                                      |                                                                                                                                                         |                            | DRAWN BY DATE<br>LPOUCHAUD 2009/03/02                                                                                         |                        |
|                                                                                                                           |                                      |                                                                                                                                                         |                            | CHECKED BY DATE<br>YIGEL 2009/03/02                                                                                           |                        |
|                                                                                                                           |                                      |                                                                                                                                                         |                            | APPROVED BY DATE<br>OPLESSIS 2012/01/31                                                                                       |                        |
|                                                                                                                           |                                      |                                                                                                                                                         |                            | MATERIAL NO. DOCUMENT NO.                                                                                                     |                        |
|                                                                                                                           |                                      |                                                                                                                                                         |                            | SEE CHART SD-98822-005                                                                                                        |                        |
|                                                                                                                           |                                      |                                                                                                                                                         |                            | THIS DRAWING CONTAINS INFORMATION THAT IS PROPRIETARY TO MOLEX INCORPORATED AND SHOULD NOT BE USED WITHOUT WRITTEN PERMISSION |                        |