

QLSP01WCF-119
(Sideview 3014)



Product Outline:

These high output reflector type Tube LEDs are available in warm white /neutral white / pure white / and cold white to suit customer's application. This LEDs can be use as a side emitter for directional lighting needs. With special binning technology, these LEDs are ideal for architecture lighting and special lighting needs.

Features:

- High brightness output @ 60mA
- Package Dimension = 3.0mmX1.4mmX1.2mm
- CRI = 80 and above
- Available in warm white / neutral white / pure white / and cold white
- RoHS compliant
- MSL 3
- Custom Bin available upon special request

Application:

- Architecture Lighting
- Garden Lighting
- Interior Lighting
- Special application lighting

Compliance and Certification:



Mechanical Property: (Dimension)

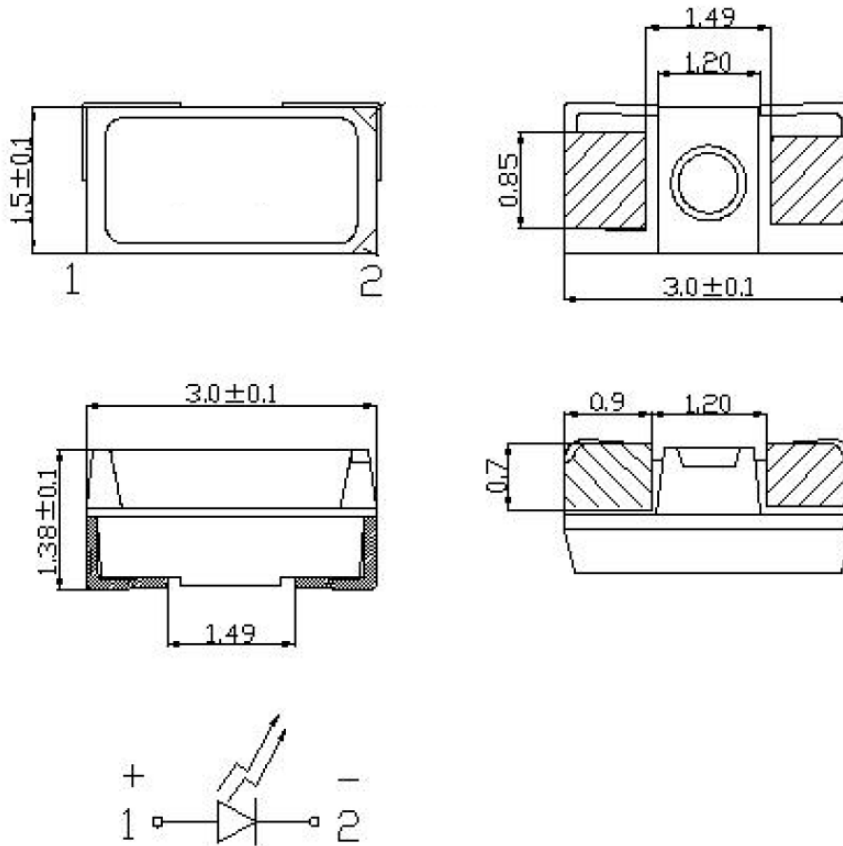

* All dimensions are in millimeters, * Tolerances are ± 0.10 mm.

Recommended Solder footprint:

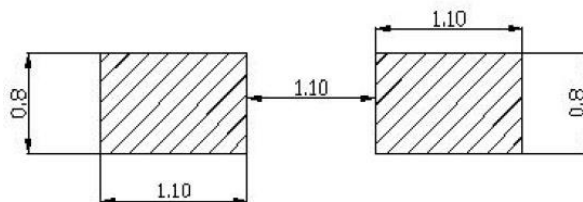

- * All dimensions are in millimeters.
- * The LEDs is designed to be reflow soldered on to a PCB. IF dip soldered that QL cannot guarantee its reliability.
- * Reflow soldering must not be performed more than twice.



Characteristics

■ Absolute Maximum Ratings

(Ta=25°C)

Parameter	Symbol	Rating	Unit
DC Forward Current	If	60	mA
Power Dissipation	Pd	0.2	W
Pulse Forward Current	Ifp	90	mA
LED Junction Temperature	TJ	120	°C
Storage Temperature	Tstg	-40 ~ 80	°C
Operation Temperature	Topr	-40 ~ 85	°C
Soldering Temperature	Tsol	260 < 5 sec	°C

- (1) Proper current rating must be observed to maintain junction temperature below maximum at all time
 (2) Ifp Condition: t < 100 μs ; D = 0.001 ; Ta= 25 °C

■ Electrical / Optical Characteristic

(Ta=25 oC)

Parameter	Symbol	Condition	Min.	Typ.	Max.	Unit
Forward Voltage	Vf	60mA	2.8		3.4	V
Color Rendering Index	Ra		80			
View Angle	θ			120		deg
Thermal Resistance	Rth			45		oC/W

- (1) Tolerance of measurement: VF=+/- 0.1V
 (2) The CRI tolerance is ±2.
 (3) Thermal resistance is calculated from junction to solder



■ Specification Chromaticity Coordinates

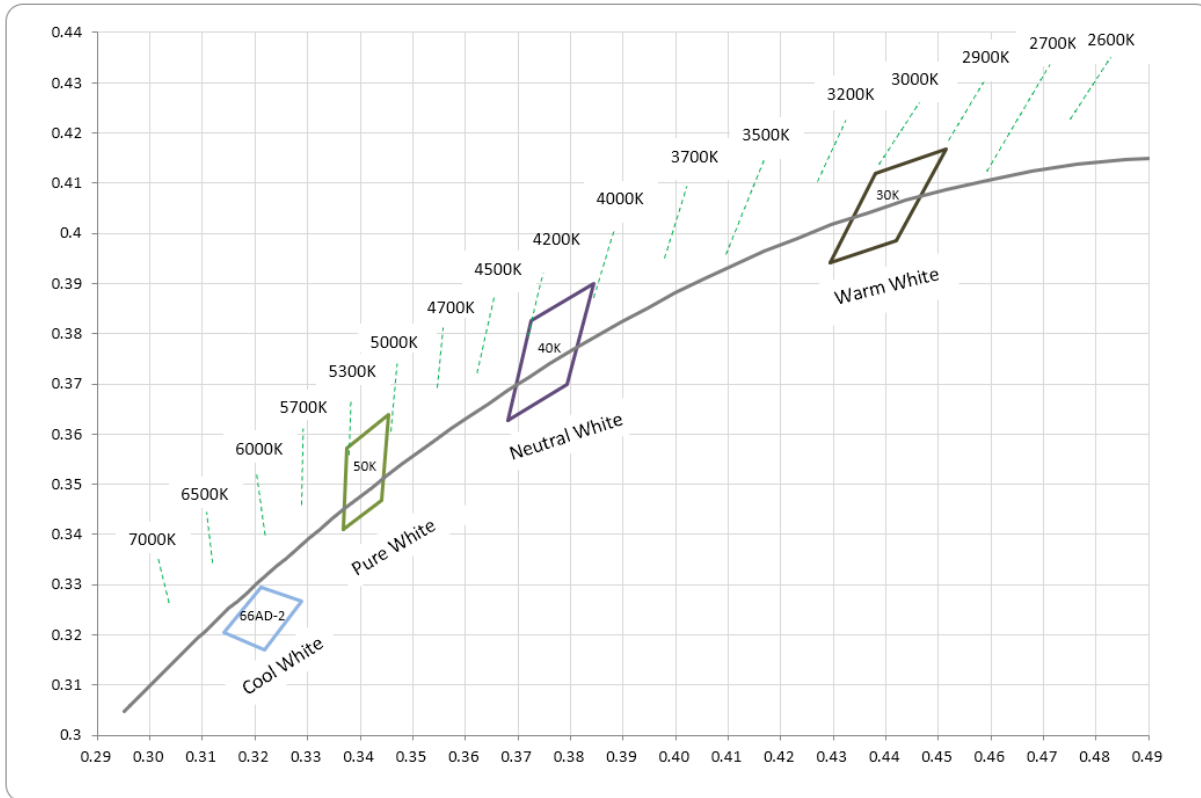

CCT 6000k		CCT 5000k		CCT 4000k		CCT 3000k	
66AD-2		50K		40K		30K	
CIE X	CIE Y	CIE X	CIE Y	CIE X	CIE Y	CIE X	CIE Y
0.3212	0.3295	0.3368	0.341	0.3681	0.3627	0.4295	0.3941
0.3289	0.3267	0.3374	0.3571	0.3725	0.3825	0.4381	0.412
0.3218	0.3171	0.3454	0.364	0.3845	0.39	0.4515	0.4168
0.3141	0.3204	0.3441	0.3468	0.3794	0.37	0.442	0.3985
0.3212	0.3295	0.3368	0.341	0.3681	0.3627	0.4295	0.3941



Forward Voltage (V_F) Bin:

VF Rank @ 60mA			
Code name	Min.	Max.	Units
01	2.8	3.0	V
23	3.0	3.2	
45	3.2	3.4	

The forward voltage tolerance is $\pm 0.1V$

Luminous Intensity Bin:

Intensity Rank (mcd) @ 60mA			
Code name	Min.	Max.	Units
QI	18	20	lm
QJ	20	22.5	
QK	22.5	25	

Luminous intensity tolerance is $\pm 7\%$



■ Characteristic Curves

(1) Color Spectrum

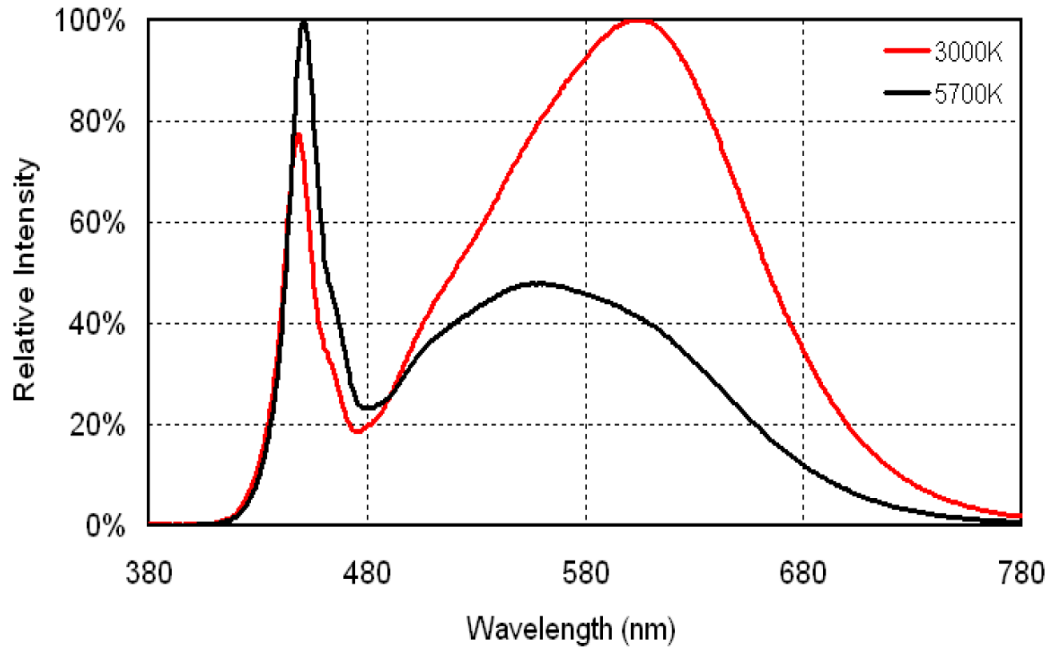

(2). Typical Representative Spatial Radiation Pattern

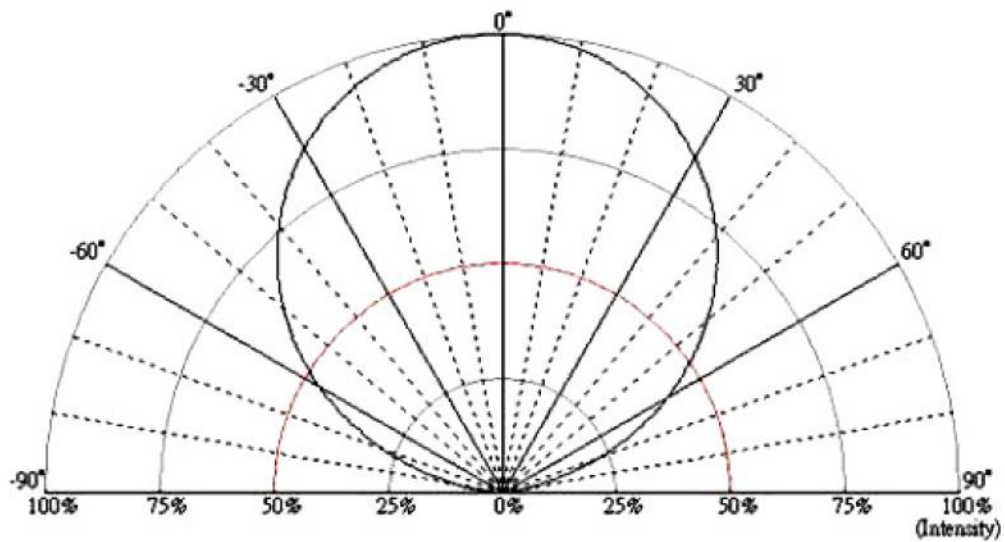

(3). Forward Current vs Relative Luminous Intensity

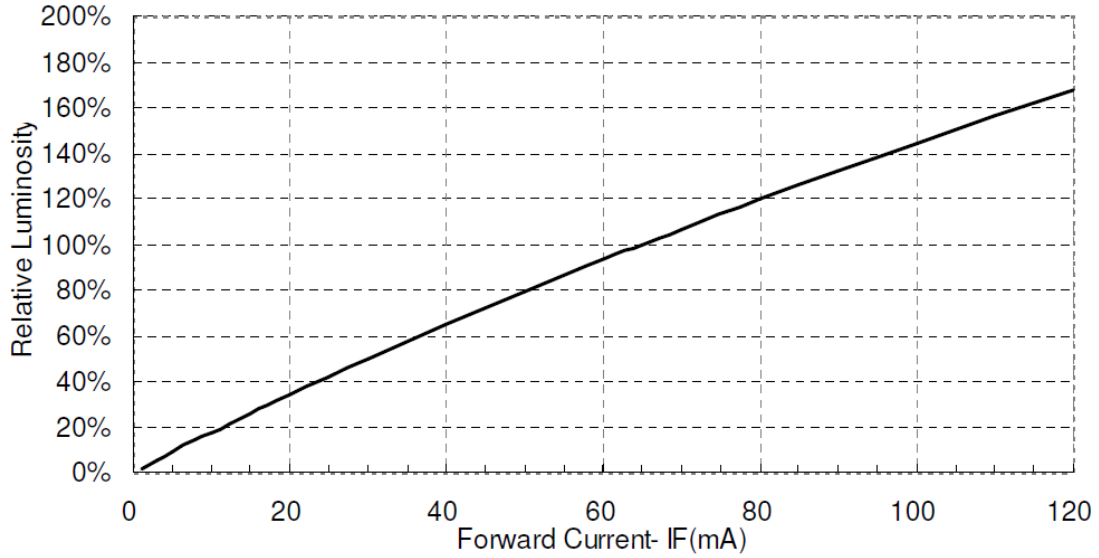

(4). Forward Current vs Forward Voltage

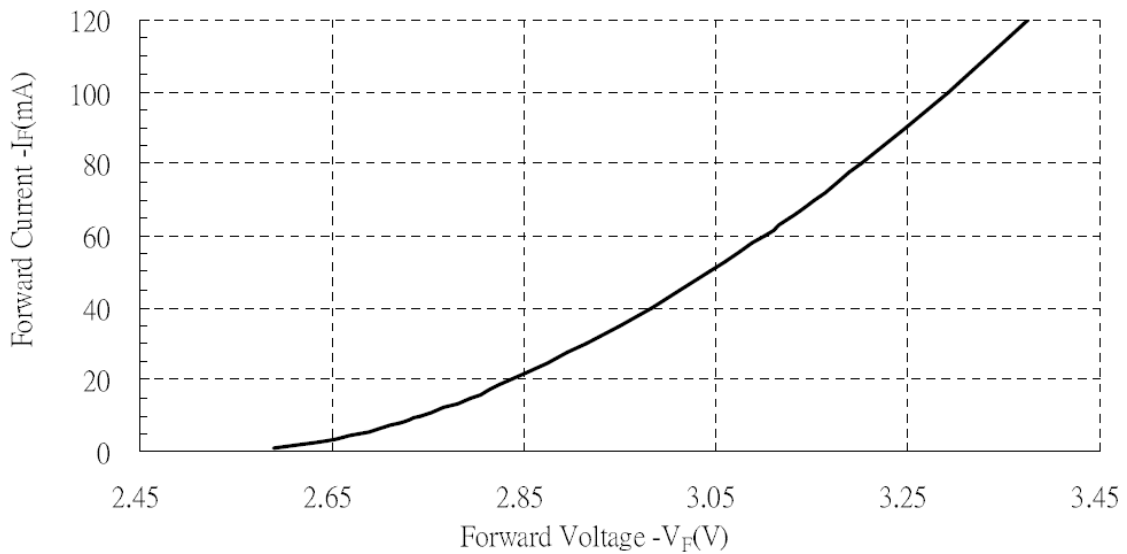

■ Reliability test:

No	Item	Condition	Time/Cycle	Sample size
1	Steady State Operating Life of Room Temperature	25°C Operating	1000 Hrs	20 pcs
2	Steady State Operating Life of Low Temperature -40°C	-40°C Operating	1000 Hrs	20 pcs
3	Steady State Operating Life of Low Temperature 60°C	60°C Operating	1000 Hrs	20 pcs
4	Steady State Operating Life of Low Temperature 85°C	85°C Operating	1000 Hrs	20 pcs
5	Low temperature storage -40°C	-40°C Storage	1000 Hrs	20 pcs
6	High temperature storage 100°C	100°C Storage	1000 Hrs	20 pcs
7	Steady State Operating Life of High Humidity Heat 60°C/90%	60°C/90% Operating	1000 Hrs	20 pcs
8	Steady State Pulse Operating Life Condition	25°C 10Hz duty=1/10 Operating	200 Cycle	20 pcs
9	Resistance to soldering heat on PCB (JEDEC MSL3)	pre-store@60°C, 60%RH for 52hrs Tslid max.=260 10sec	3 Times	20 pcs
10	Heat Cycle Test (JEDEC MRC)	25°C~65°C~-10°C, 90%RH, 24hr/1cycle	10 Cycle	20 pcs
11	Thermal shock	-40°C/ 20minr~ 5minr~100°C /20min	300 Cycle	20 pcs

■ Judgment Criteria:

Item	Symbol	Test Condition	Judgment Criteria
Forward Voltage	Vf	60 mA	$\Delta Vf < 10\%$
Luminous Flux	Iv	60 mA	$\Delta Iv < 30\%$



■ Solder Profile:

-The recommended reflow soldering profile is as follows (temperatures indicated are as measured on the surface of the LED resin):

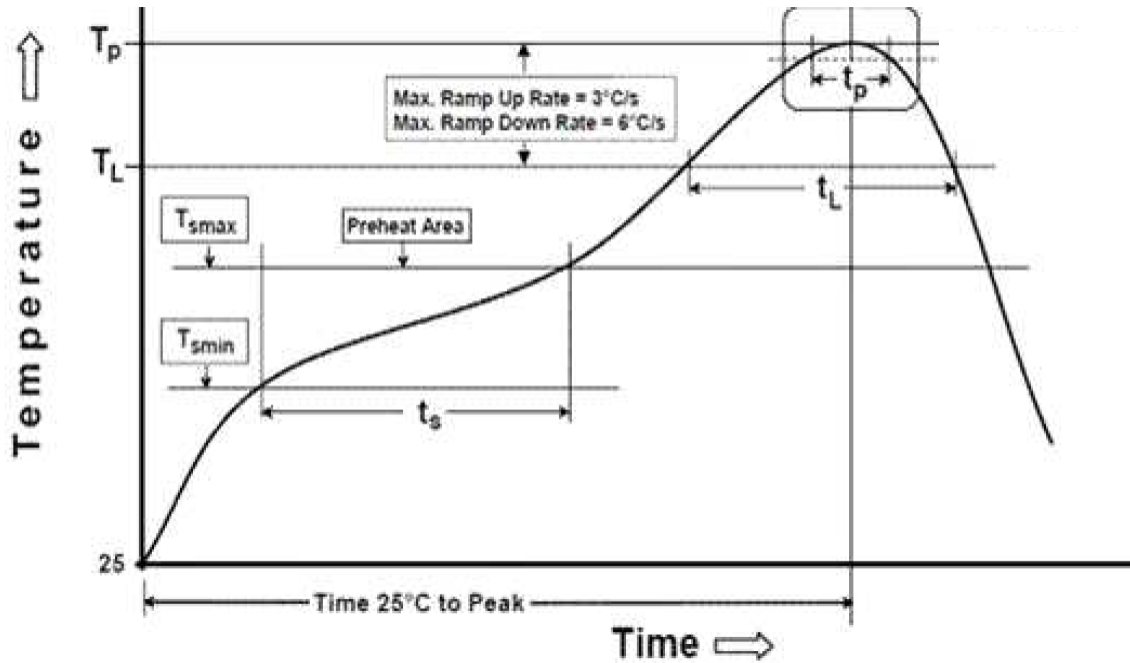

Profile Feature	Sn-Pb Eutectic Assembly	Pb-Free Assembly
Temperature Min(T_{smin})	100°C	150°C
Temperature Max(T_{smax})	150°C	200°C
Time(t_a) from (T_{smin} to T_{smax})	60-120 seconds	60-120 seconds
Ramp-up rate(T_L to T_p)	3°C/second max.	3°C/second max.
Liquidous Temperature(T_L)	183°C	217°C
Time(t_L) maintained above T_L	60-150 seconds	60-150 seconds
Peak package body temperature(T_p)	235°C	260°C
Time within 5°C of Actual Peak temperature (t_p)	20seconds*	30 seconds*
Ramp-down rate(T_p to T_L)	6°C/second max.	6°C/second max.
Time 25°C to peak temperature	6 minutes max.	8 minutes max.

* Tolerance for peak profile temperature (T_p) is defined as a supplier minimum and a user maximum.



■ Taping & Packing:

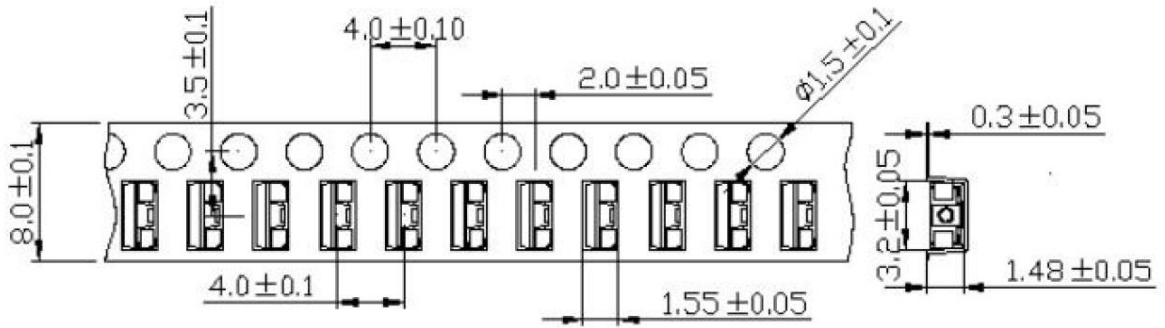

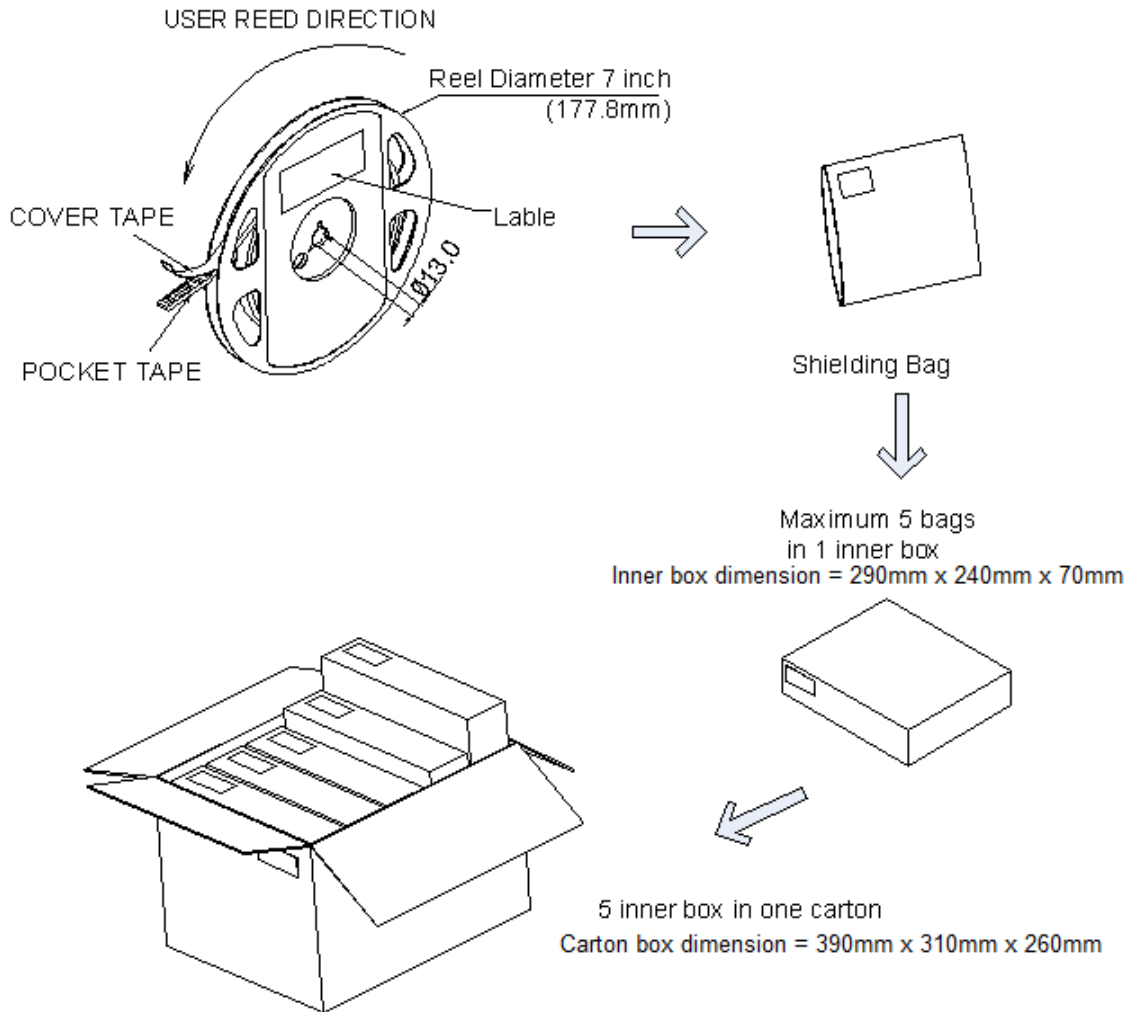

Unit : mm



■ Labeling

 Quantity: XXXX



 Quelighting P/N: XXXXXX

 Lot number: XXXXX

Iv Bin: XX

Color Bin: XX

Vf Bin: XX

Date Code: XXXX

■ Ordering Information:

Part #	Multiple Quantities	Quantity per Reel
QLSP01WCF-119		3000 pcs

■ Revision History:

Revision Date:	Changes:	Version #:
1-29-2016	Initial release	1.0
08-26-2019	Update the led performance, operation current and CIE binning	1.1

