

**ESD protected N-Channel Enhancement Mode MOSFET**

# MTNK5C3

|                        |       |
|------------------------|-------|
| BV <sub>DSS</sub>      | 30V   |
| I <sub>D</sub>         | 100mA |
| R <sub>DS(on)MAX</sub> | 8Ω    |

**Description**

- Low voltage drive(2.5V drive) makes this device ideal for portable equipment.
- High speed switching
- ESD protected device
- Pb-free lead plating & halogen-free package

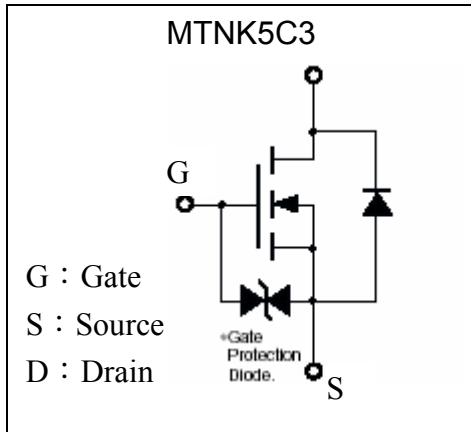
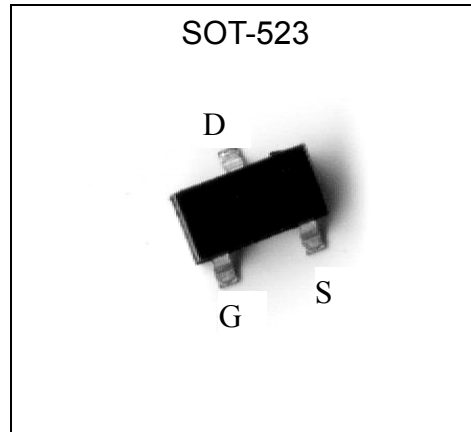
**Symbol**

**Outline**

**Absolute Maximum Ratings (Ta=25°C)**

| Parameter  |            | Symbol                            | Limits   | Unit |
|--|------------|-----------------------------------|----------|------|
| Drain-Source Voltage                             |            | BV <sub>DSS</sub>                 | 30       | V    |
| Gate-Source Voltage                              |            | V <sub>GS</sub>                   | ±20      | V    |
| Drain Current                                    | Continuous | I <sub>D</sub>                    | ±100     | mA   |
|  | Pulsed     | I <sub>DP</sub>                   | ±200 *1  | mA   |
| Reverse Drain Current                            | Continuous | I <sub>DR</sub>                   | ±100     | mA   |
|  | Pulsed     | I <sub>DRP</sub>                  | ±200 *1  | mA   |
| Total Power Dissipation                          |            | P <sub>D</sub>                    | 150 *2   | mW   |
| ESD susceptibility                               |            |                                   | 750 *3   | V    |
| Operating Junction and Storage Temperature Range |            | T <sub>j</sub> ; T <sub>stg</sub> | -55~+150 | °C   |
| Thermal Resistance, Junction-to-Ambient          |            | R <sub>th,ja</sub>                | 833      | °C/W |

- Note : \*1. Pulse Width ≤ 10μs, Duty cycle ≤ 1%  
 \*2. With each pin mounted on the recommended lands.  
 \*3. Human body model, 1.5kΩ in series with 100pF



**Electrical Characteristics (Ta=25°C)**

| Symbol                    | Min. | Typ. | Max. | Unit | Test Conditions  |
|---------------------------|------|------|------|------|--|
| <b>Static</b>             |      |      |      |      |  |
| BV <sub>DSS</sub>         | 30   | -    | -    | V    | V <sub>GS</sub> =0, I <sub>D</sub> =100μA  |
| V <sub>GS(th)</sub>       | 0.8  | 1.3  | 1.5  | V    | V <sub>DS</sub> =3V, I <sub>D</sub> =100μA   |
| I <sub>GSS</sub>          | -    | -    | ±1   | μA   | V <sub>GS</sub> =±20V, V <sub>DS</sub> =0  |
| I <sub>DSS</sub>          | -    | -    | 100  | nA   | V <sub>DS</sub> =30V, V <sub>GS</sub> =0   |
| R <sub>DSON</sub>         | -    | 3.4  | 8    | Ω    | V <sub>GS</sub> =4V, I <sub>D</sub> =10mA  |
|                           | -    | 6.9  | 13   |      | V <sub>GS</sub> =2.5V, I <sub>D</sub> =1mA   |
| GFS                       | 20   | 50   | -    | mS   | V <sub>DS</sub> =3V, I <sub>D</sub> =10mA  |
| <b>Dynamic</b>            |      |      |      |      |  |
| C <sub>iss</sub>          | -    | 12.5 | -    | pF   | V <sub>DS</sub> =5V, V <sub>GS</sub> =0, f=1MHz  |
| C <sub>oss</sub>          | -    | 7.3  | -    |      |  |
| C <sub>rss</sub>          | -    | 3.5  | -    |      |  |
| t <sub>d(on)</sub>        | -    | 15   | -    | ns   | V <sub>DD</sub> ≐ 5V, I <sub>D</sub> =10mA, V <sub>GS</sub> =5V, R <sub>L</sub> =500Ω, R <sub>G</sub> =10Ω |
| t <sub>r</sub>            | -    | 35   | -    |      |  |
| t <sub>d(off)</sub>       | -    | 75   | -    |      |  |
| t <sub>f</sub>            | -    | 75   | -    |      |  |
| <b>Source-Drain Diode</b> |      |      |      |      |  |
| *V <sub>SD</sub>          | -    | 0.88 | 1.2  | V    | V <sub>GS</sub> =0V, I <sub>S</sub> =100mA   |

\*Pulse Test : Pulse Width ≤300μs, Duty Cycle ≤2%

**Ordering Information**

| Device  | Package  | Shipping               | Marking |
|---------|--|------------------------|---------|
| MTNK5C3 | SOT-523<br>(Pb-free lead plating & halogen-free package) | 3000 pcs / Tape & Reel | KN      |



**Typical Characteristics**

Typical Output Characteristics

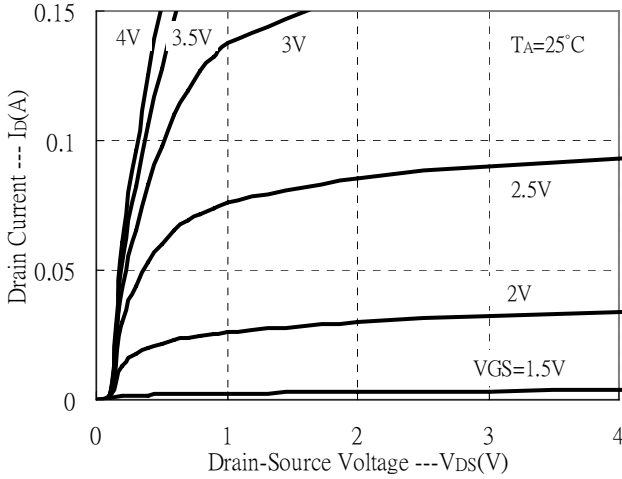

Gate Threshold Voltage vs Channel Temperature

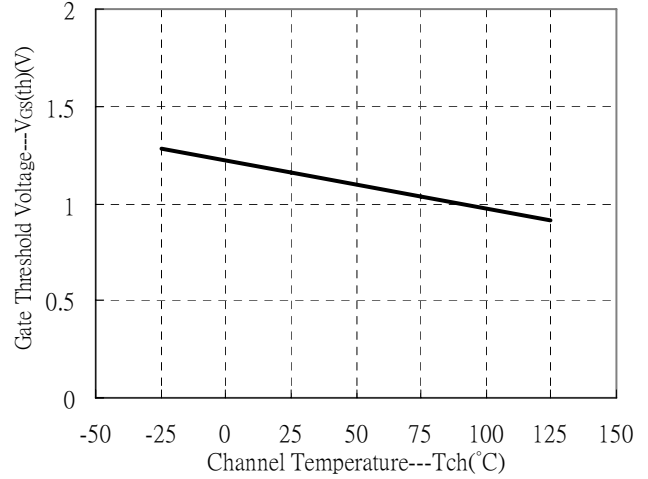

Typical Transfer Characteristics

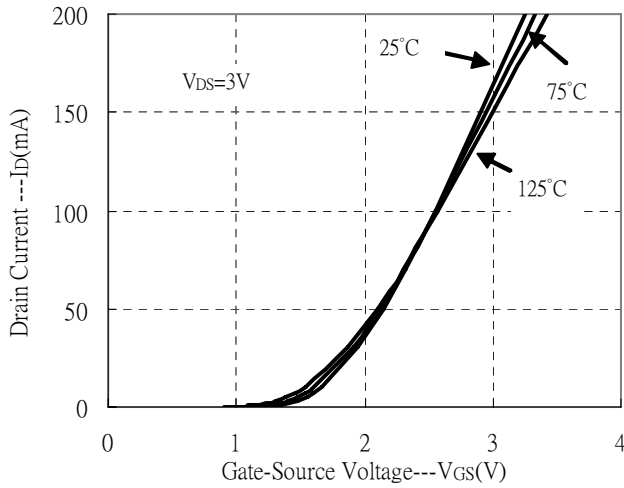

Static Drain-Source On-state Resistance with Temperature

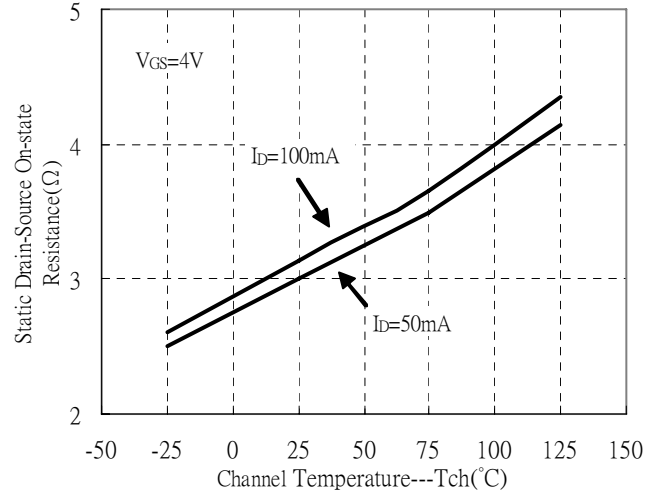

Static Drain-Source On-State resistance vs Drain Current

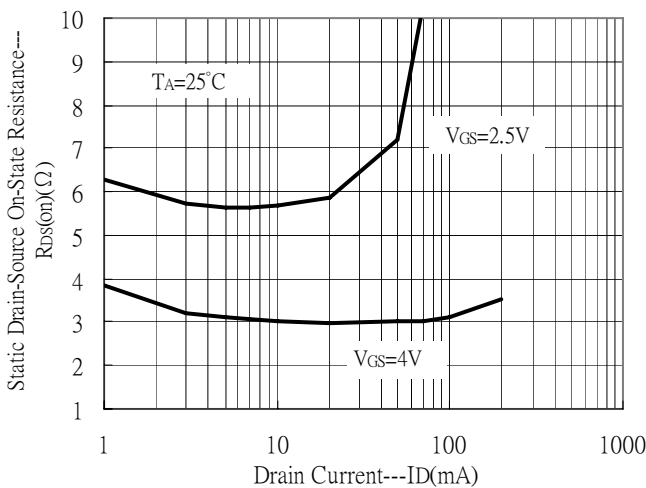

Static Drain-Source On-State resistance vs Drain Current

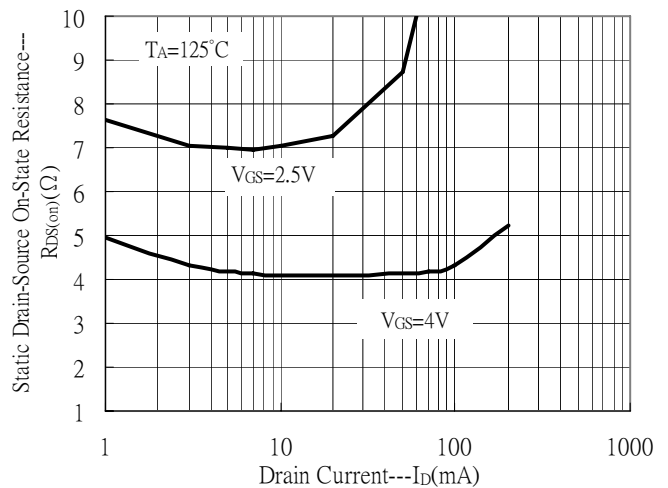

**Typical Characteristics(Cont.)**

Static Drain-Source On-State Resistance vs Drain Current

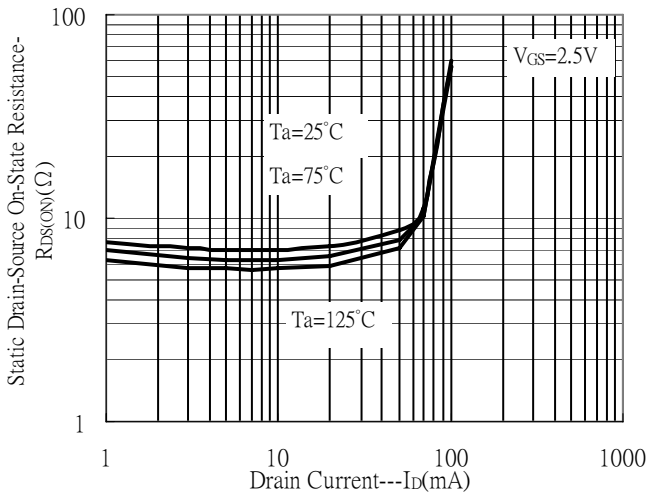

Static Drain-Source On-State Resistance vs Drain Current

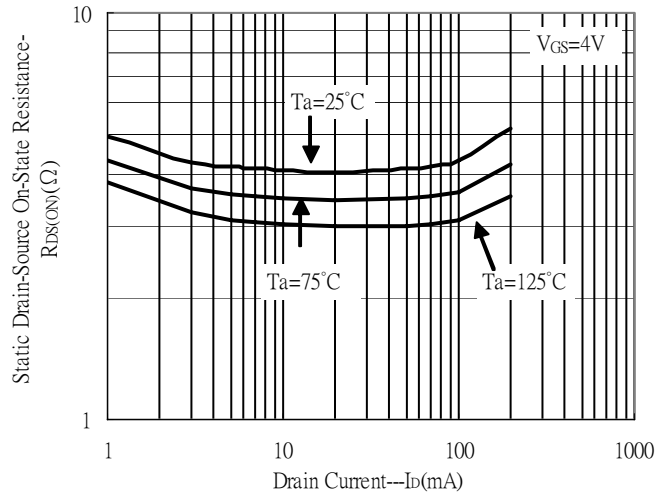

Static Drain-Source On-State Resistance vs Gate-Source Voltage

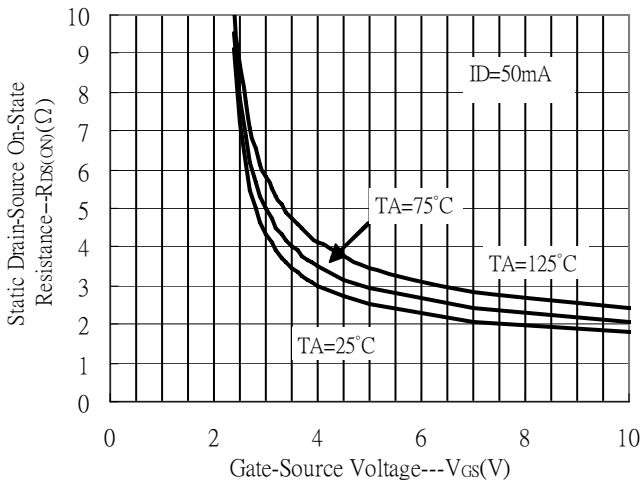

Static Drain-Source On-State Resistance vs Gate-Source Voltage

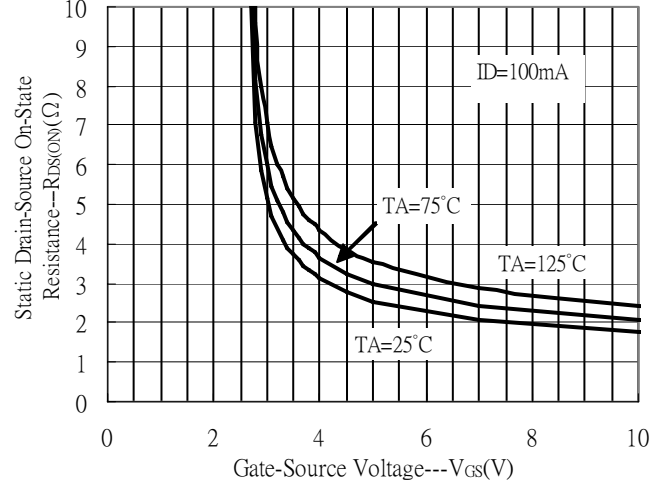

Reverse Drain Current vs Source-Drain Voltage(I)

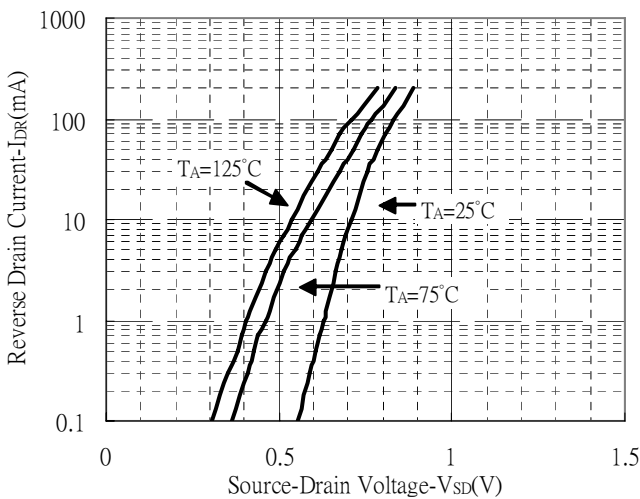

Reverse Drain Current vs Source-Drain Voltage(II)

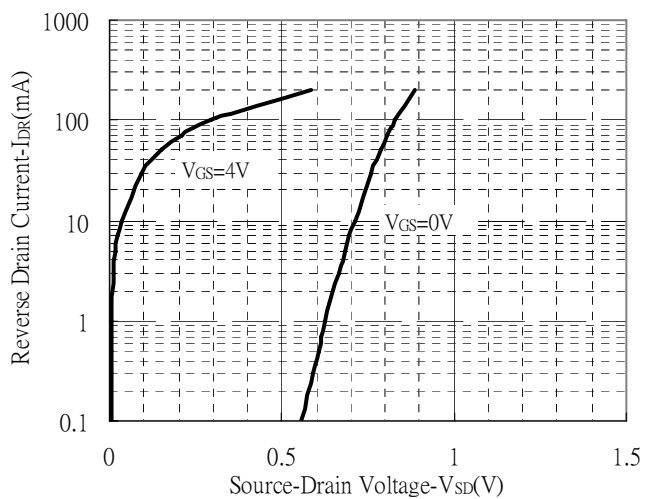



### Typical Characteristics(Cont.)

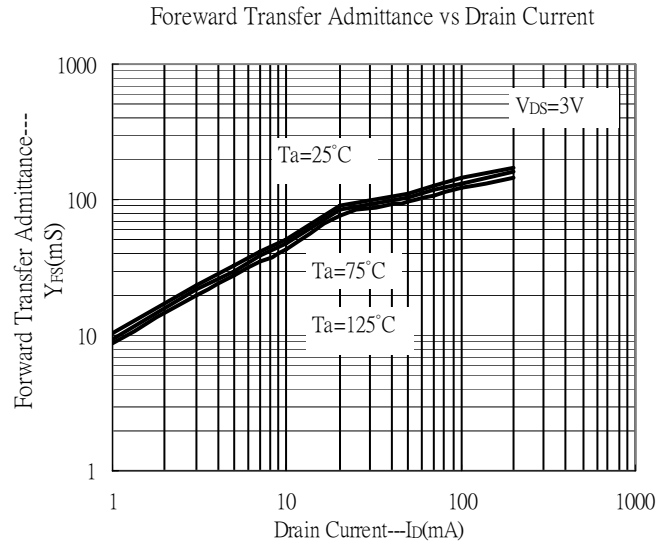
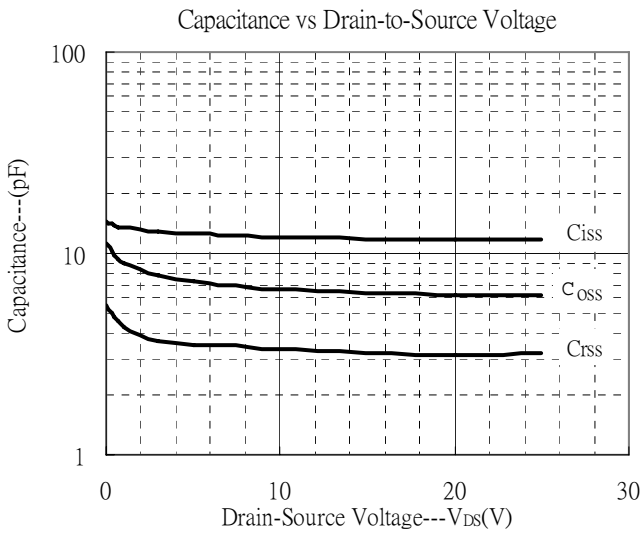

**Reel Dimension**

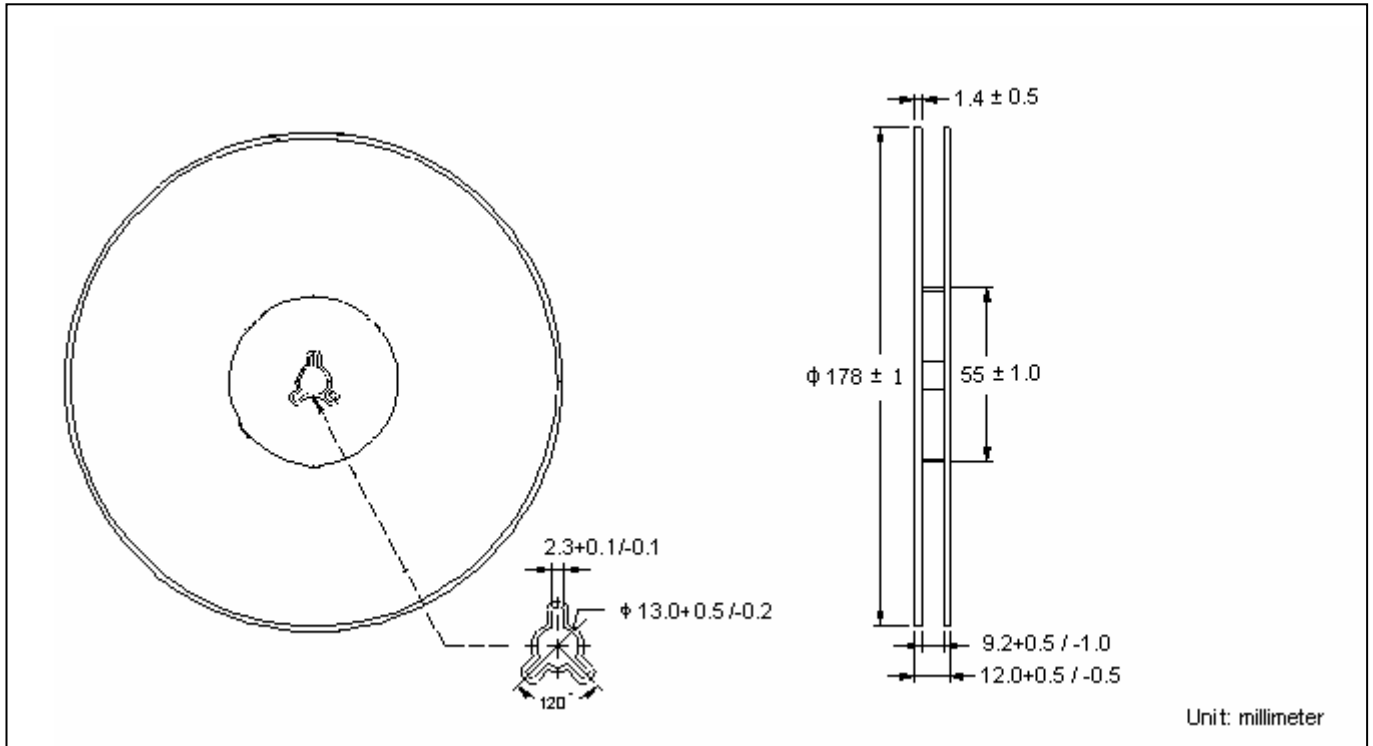

**Carrier Tape Dimension**

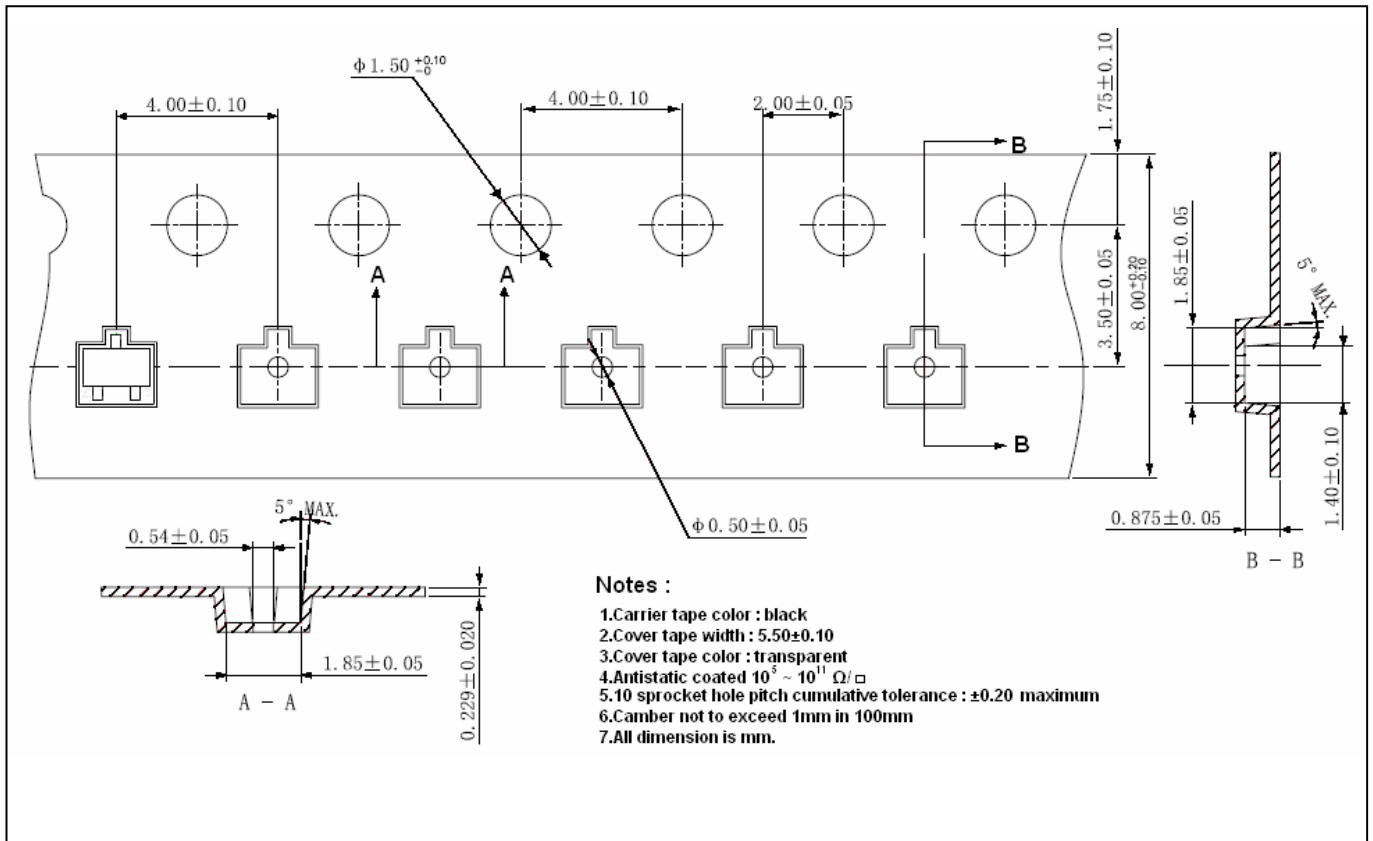

**Recommended wave soldering condition**

|                 |                  |                 |
|-----------------|------------------|-----------------|
| Product         | Peak Temperature | Soldering Time  |
| Pb-free devices | 260 +0/-5 °C     | 5 +1/-1 seconds |

**Recommended temperature profile for IR reflow**

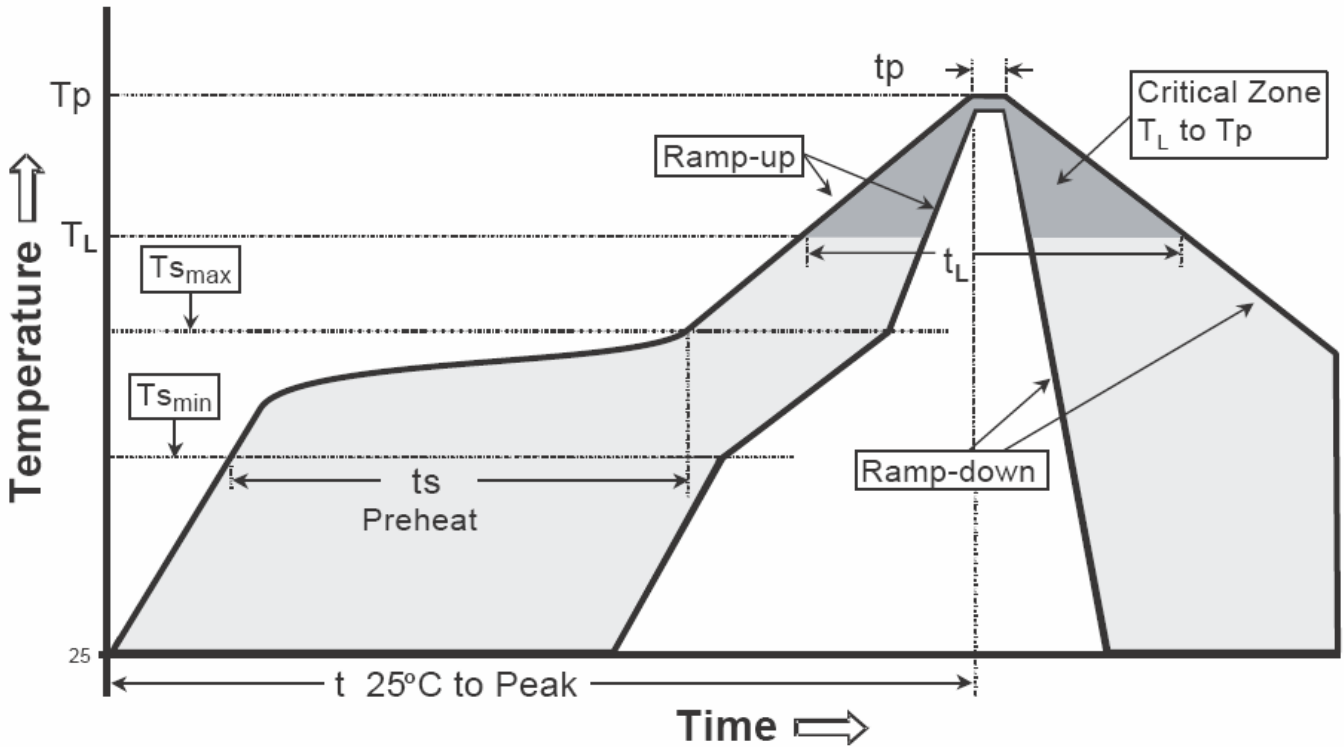

| Profile feature   | Sn-Pb eutectic Assembly | Pb-free Assembly |
|---|-------------------------|------------------|
| Average ramp-up rate (T <sub>smax</sub> to T <sub>p</sub> ) | 3°C/second max.         | 3°C/second max.  |
| Preheat   |                         |                  |
| -Temperature Min(T <sub>s min</sub> )                       | 100°C                   | 150°C            |
| -Temperature Max(T <sub>s max</sub> )                       | 150°C                   | 200°C            |
| -Time(t <sub>s min</sub> to t <sub>s max</sub> )            | 60-120 seconds          | 60-180 seconds   |
| Time maintained above:                                      |                         |                  |
| -Temperature (T <sub>L</sub> )                              | 183°C                   | 217°C            |
| - Time (t <sub>L</sub> )                                    | 60-150 seconds          | 60-150 seconds   |
| Peak Temperature(T <sub>P</sub> )                           | 240 +0/-5 °C            | 260 +0/-5 °C     |
| Time within 5°C of actual peak temperature(tp)              | 10-30 seconds           | 20-40 seconds    |
| Ramp down rate  | 6°C/second max.         | 6°C/second max.  |
| Time 25 °C to peak temperature                              | 6 minutes max.          | 8 minutes max.   |

Note : All temperatures refer to topside of the package, measured on the package body surface.

**SOT-523 Dimension**

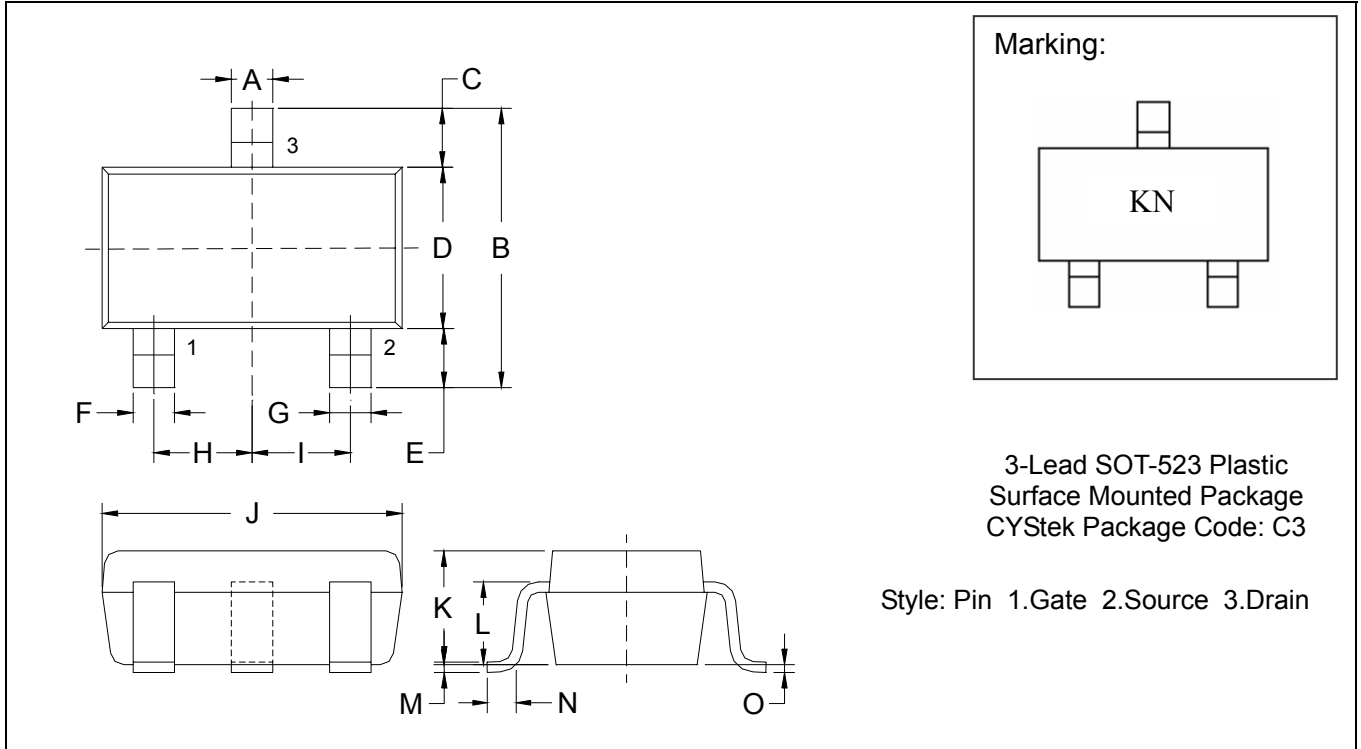

\*: Typical

| DIM | Inches  |        | Millimeters |      | DIM | Inches  |        | Millimeters |      |
|-----|---------|--------|-------------|------|-----|---------|--------|-------------|------|
|     | Min.    | Max.   | Min.        | Max. |     | Min.    | Max.   | Min.        | Max. |
| A   | 0.0079  | 0.0157 | 0.20        | 0.40 | I   | *0.0197 | -      | *0.50       | -    |
| B   | 0.0591  | 0.0669 | 1.50        | 1.70 | J   | 0.0610  | 0.0650 | 1.55        | 1.65 |
| C   | 0.0118  | 0.0197 | 0.30        | 0.50 | K   | 0.0276  | 0.0315 | 0.70        | 0.80 |
| D   | 0.0295  | 0.0335 | 0.75        | 0.85 | L   | 0.0224  | 0.0248 | 0.57        | 0.63 |
| E   | 0.0118  | 0.0197 | 0.30        | 0.50 | M   | 0.0020  | 0.0059 | 0.05        | 0.15 |
| F   | 0.0039  | 0.0118 | 0.10        | 0.30 | N   | 0.0039  | 0.0118 | 0.10        | 0.30 |
| G   | 0.0039  | 0.0118 | 0.10        | 0.30 | O   | 0       | 0.0031 | 0           | 0.08 |
| H   | *0.0197 | -      | *0.50       | -    |     |         |        |             |      |

Notes: 1.Controlling dimension: millimeters.  
 2.Maximum lead thickness includes lead finish thickness, and minimum lead thickness is the minimum thickness of base material.  
 3.If there is any question with packing specification or packing method, please contact your local CYStek sales office.

**Material:**

- Lead: Pure tin plated.
- Mold Compound: Epoxy resin family, flammability solid burning class: UL94V-0

**Important Notice:**

- All rights are reserved. Reproduction in whole or in part is prohibited without the prior written approval of CYStek.
- CYStek reserves the right to make changes to its products without notice.
- CYStek **semiconductor products are not warranted to be suitable for use in Life-Support Applications, or systems.**
- CYStek assumes no liability for any consequence of customer product design, infringement of patents, or application assistance.