

FEATURES

- 0...1 to 0...250 psi gage or differential
- High impedance bridge
- Miniature package
- Different pinning configurations
- Usable for wet/wet applications⁸

SERVICE

All media compatible with

port 1: - polyetherimide
- silver-filled silicone
- silicon nitride

port 2⁹: - polyetherimide
- fluor-silicone
- silicon



Scale: 1 cm
1 inch

SPECIFICATIONS

Maximum ratings

| | |
|---|--------------------------|
| Supply voltage | 16 V |
| Temperature limits | |
| Storage | -55 to +100°C |
| Operating | -40 to +85°C |
| Lead temperature (10 sec. soldering) | 300°C |
| Humidity limits | 0...100%RH |
| Vibration (MIL-STD-202, Meth. 213) | 150 g half sine 11 msec. |
| Mechanical shock (qualification tested) | 150 g |
| Proof pressure ¹ | |
| all 1 and 5 psi devices | 20 psi |
| all 15 psi devices | 45 psi |
| all 30 psi devices | 60 psi |
| all 100 psi devices | 200 psi |
| all 250 psi devices | 500 psi |

ELECTRICAL CONNECTION

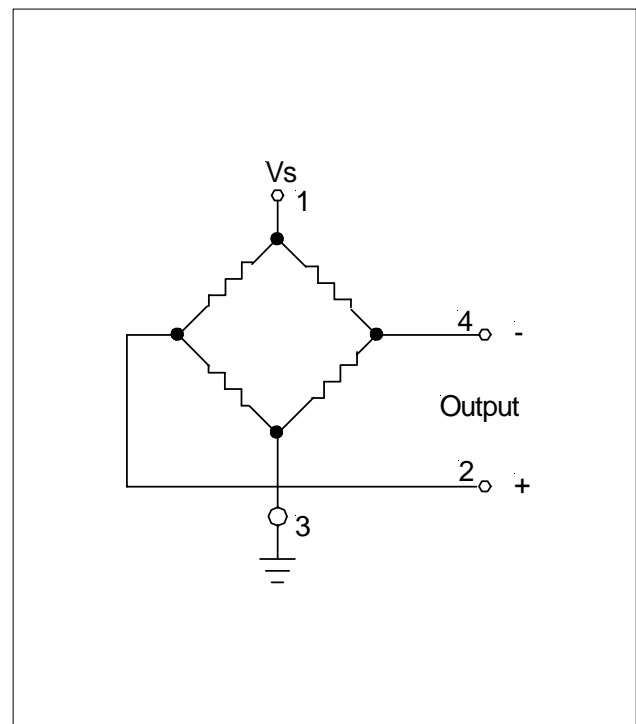

PRESSURE SENSOR CHARACTERISTICS

$V_s = 10.0 \pm 0.01$ V, $t_{amb} = 20^\circ\text{C}$ (unless otherwise noted)

| Listing | Order number | Operating pressure | Full-scale span ² | | |
|-----------|--------------|------------------------|------------------------------|---------|---------|
| | | | Min. | Typ. | Max. |
| 26PCAFaxx | 26PC0070xxA | 0 - 1 psi (69 mbar) | 14.7 mV | 16.7 mV | 18.7 mV |
| 26PCBFaxx | 26PC0350xxA | 0 - 5 psi (345 mbar) | 47 mV | 50 mV | 53 mV |
| 26PCCFAxx | 26PC1000xxA | 0 - 15 psi (1034 mbar) | 97 mV | 100 mV | 103 mV |
| 26PCDFaxx | 26PC2000xxA | 0 - 30 psi (2068 mbar) | 97 mV | 100 mV | 103 mV |
| 26PCFFaxx | 26PC7000xxA | 0 - 100 psi (6.9 bar) | 95 mV | 100 mV | 105 mV |
| 26PCGFaxx | 26PC17K0xxA | 0 - 250 psi (17.2 bar) | 143 mV | 150 mV | 157 mV |

COMMON PERFORMANCE CHARACTERISTICS

$V_s = 10.0 \pm 0.01$ V, $t_{amb} = 25^\circ\text{C}$ (unless otherwise noted)

| Characteristics | | Min. | Typ. | Max. | Unit | |
|---|-------------------------|------|--------------|------|------|--------|
| Zero pressure offset | all 100 psi devices | -2.0 | | +2.0 | mV | |
| | all other devices | -1.5 | | +1.5 | | |
| Temperature effects (0 - 50°C) ⁴ | | | | | | |
| Offset | all 1 to 15 psi devices | | ±0.5 | ±1.0 | | |
| | all 30 psi devices | | ±0.75 | ±1.5 | | |
| | all other devices | | ±1.0 | ±2.0 | | |
| Span | all 1 psi devices | | ±1.0 | ±2.0 | | |
| | all other devices | | ±0.75...±1.0 | ±1.5 | | |
| Linearity (P2 > P1, BSL) ³ | all 1 to 15 psi devices | | ±0.25 | ±0.5 | | % span |
| | all 30 psi devices | | ±0.1 | ±0.2 | | |
| | all other devices | | ±0.1 | ±0.7 | | |
| Repeatability and hysteresis ⁵ | | | ±0.2 | | | |
| Long term stability ⁷ | | | ±0.5 | | | |
| Input impedance | | 5.5 | 7.5 | 11.5 | kΩ | |
| Output impedance | | 1.5 | 2.5 | 3.0 | | |
| Response time ⁶ | | | | 1.0 | ms | |

Specification notes:

- The maximum specified pressure which may be applied to the sensor without causing a permanent change in the output characteristics.
- Span is the algebraic difference between the output voltage at full-scale pressure and the output at zero pressure. Span is ratiometric to the supply voltage.
- Linearity (BSL), the deviation of measured output at constant temperature (25°C) from "Best Straight Line" determined by three points, offset pressure, full-scale pressure and half full-scale pressure.

$$\left[V_{\frac{1}{2} \text{ full scale}} - \left\{ \frac{V_{\text{full scale}} - V_{\text{offset}}}{(\text{full scale pressure})} \times \left(\frac{1}{2} \text{ full scale pressure} \right) + V_{\text{offset}} \right\} \right] : 2 (V_{\text{full scale}}) \times 100 \%$$

where: V = measured value for each device

- Error band of the offset voltage, span or bridge impedance in the specified temperature range, relative to the 25°C reading.
- Repeatability, the deviation in output readings for successive application of any given input pressure (all other conditions remaining constant). Hysteresis, the error defined by the deviation in output signal obtained when a specific pressure point is approached first with increasing pressure, then with decreasing pressure or vice versa (all other conditions remaining constant).
- Response time for 0 to full-scale pressure step change, readings taken at 10 % and 90 % of full-scale pressure.
- Long term stability of offset and span over a period over one year.
- The sensors might be used on both ports, for media compatible with the components, specified under "Service" (page 1).
- Other sealing materials are available on request.** Minimum order quantities might be required.
- Other pressure port styles, like barbed ones, luers, modular, M5, needle style or flow through connection, are available on request.** Minimum order quantities might be required.

OUTLINE DRAWINGS¹⁰

26PCxxxxG6A (single inline pinning, 1 x 4), gage pressure devices

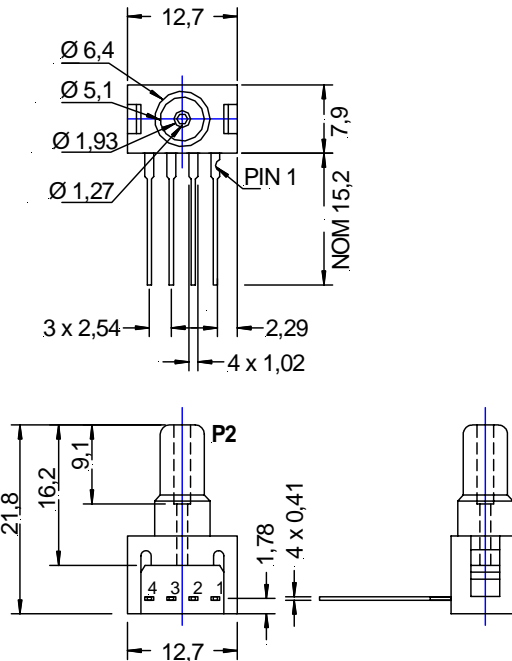

mass: 2 g

dimensions in mm

26PCxxxxG2A (dual inline pinning, 2 x 2), gage pressure devices

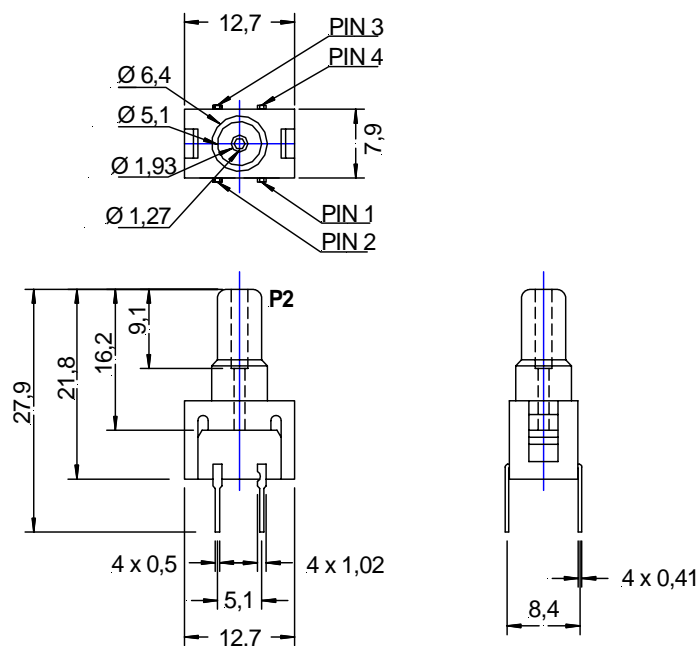

mass: 2 g

dimensions in mm

26PC Series (psi)

Honeywell

Temp. compensated and calibrated pressure sensors

OUTLINE DRAWINGS¹⁰

26PCxxxxD6A (single inline pinning, 1 x 4), differential pressure devices

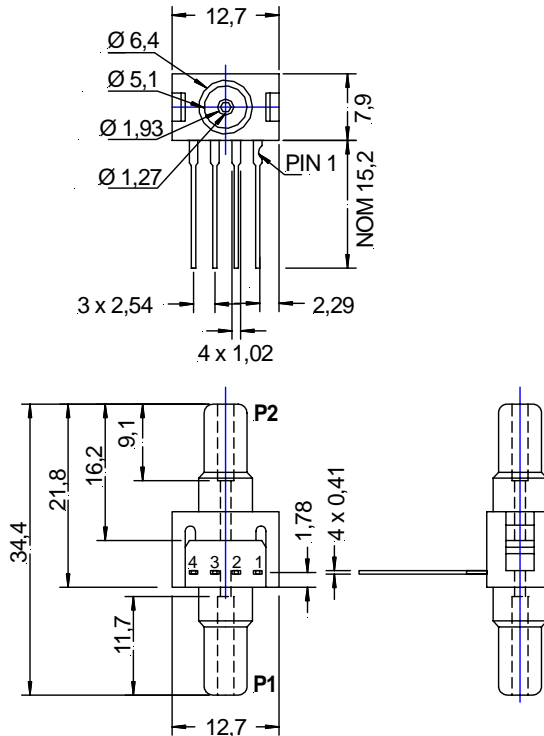

mass: 2 g

dimensions in mm

ORDERING INFORMATION

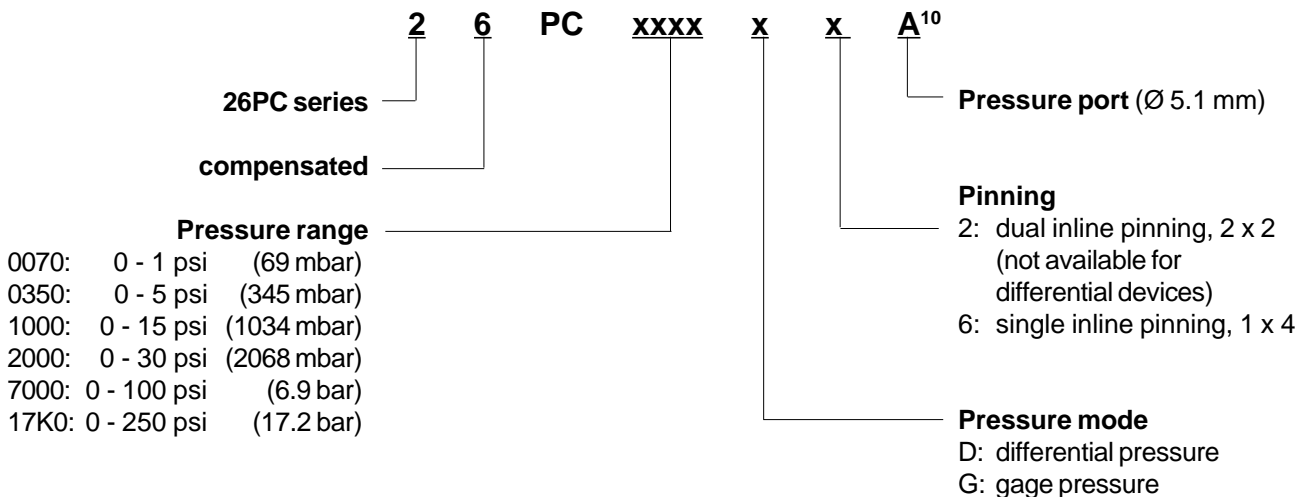

Sensortronics reserves the right to make changes to any products herein. Sensortronics does not assume any liability arising out of the application or use of any product or circuit described herein, neither does it convey any license under its patent rights nor the rights of others.