

**PLEASE CHECK WWW.MOLEX.COM FOR LATEST PART INFORMATION**

**Part Number:** [0008550124](#)  
**Status:** **Active**  
**Overview:** [kk](#)  
**Description:** KK® High Pressure Crimp Terminal 7879, 22-30 AWG, Reel Selective Gold (Au)

**Documents:**

[Drawing \(PDF\)](#) [RoHS Certificate of Compliance \(PDF\)](#)  
[Product Specification PS-7879 \(PDF\)](#)

**General**

Product Family	Crimp Terminals
Series	<a href="#">7879</a>
Crimp Quality Equipment	Yes
Overview	<a href="#">kk</a>
Product Name	KK® High Pressure

**Physical**

Gender	Female
Material - Metal	Brass
Material - Plating Mating	Gold
Material - Plating Termination	Tin
Packaging Type	Reel
Plating min: Mating (µin)	15
Plating min: Mating (µm)	0.38
Plating min: Termination (µin)	100
Plating min: Termination (µm)	2.50
Termination Interface: Style	Crimp or Compression
Wire Insulation Diameter	1.57mm (.062") max.
Wire Size AWG	22, 24, 26, 28, 30
Wire Size mm²	N/A

**Material Info**

Old Part Number	7879-1(P208)
-----------------	--------------

**Reference - Drawing Numbers**

Product Specification	PS-7879
Sales Drawing	SD-7879

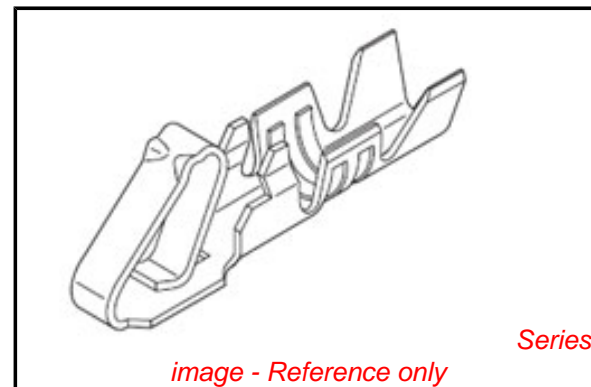

*image - Reference only*

**EU RoHS**

**ELV and RoHS  
Compliant**  
**REACH SVHC  
Contains SVHC: No**  
**Halogen-Free  
Status**

**China RoHS**



**Need more information on product  
environmental compliance?**

Email [productcompliance@molex.com](mailto:productcompliance@molex.com)  
 For a multiple part number RoHS Certificate of Compliance, [click here](#)

Please visit the [Contact Us](#) section for any non-product compliance questions.

**Search Parts in this Series**

[7879Series](#)

**Application Tooling | [FAQ](#)**

*Tooling specifications and manuals are found by selecting the products below. Crimp Height Specifications are then contained in the Application Tooling Specification document.*

**Global**

Description	Product #
Extraction Tool	<a href="#">0011030022</a>
Terminator Die	<a href="#">0011402251</a>
Insertion Tool	<a href="#">0638120000</a>
Hand Crimp Tool	<a href="#">0638190800</a>
Mini-Mac™	<a href="#">0638915100</a>
Applicator	

NOTES:

1. MATERIAL:
  - 1) 70/30 BRASS, PER ES-124C-6.
  - 2) PHOS. BRONZE, PER ES-124E-5.
2. FINISH: SEE LEGEND.
3. THIS PART CONFORMS TO PRODUCT SPEC. 7879.
4. CRIMP FOR 24-30 AWG. WIRE WITH .060/(1.52) MAX. INSULATION DIA.
5. THIS TERMINAL TO BE USED IN 7880 HOUSING.
6. DIMENSIONS GIVEN ACROSS CENTERLINES ARE SYMMETRICAL ABOUT THOSE CENTERLINES WITHIN HALF THE TOTAL TOLERANCE.
7. CRIMP WILL ACCEPT 22 AWG. WIRE WITH .062/(1.57) MAX. INSULATION DIA.

LEGEND:

MATERIAL  
 (.20<sup>+0.000</sup> / .020<sup>-0.008</sup>) / .008<sup>+0.0000</sup> / .0008 THICK

7879-\*(\*\*\*)\*

PLATING

WINDING SPEC.  
 BLANK= PER ES-339-B  
 L= LOOSE

70/30 BRASS, PER ES-124C-6.  
 2= PHOS. BRONZE, PER ES-124E-5.

(102) OVERALL TIN: .000200/(0.00508) MIN. OVER .000100/(0.00254) MIN. COPPER.  
 \*(P909) OVERALL HOT TN DP: .000100/(0.00254) MIN.  
 \*(P154) OVERALL TIN: .000100/(0.00254) MIN. OVERALL NICKEL UNDERPLATE: .000050/(0.00127) MIN.  
 (208) SELECT GOLD: .000015/(0.00038) MIN.  
 \*SELECT TIN: .000100/(0.00254) MIN.  
 OVERALL NICKEL UNDERPLATE: .000050/(0.00127) MIN.  
 (228) SELECT GOLD: .000030/(0.00076) MIN.  
 \*SELECT TIN: .000100/(0.00254) MIN.  
 OVERALL NICKEL UNDERPLATE: .000050/(0.00127) MIN.

\*THE PRIMARY SHIPPING CARTON WILL BE LABELED 'COMPLIANT TO RoHS DIRECTIVE 2002/95/EC AND ELV ANNEX II OF DIRECTIVE 2000/53/EC.' CARTONS WITHOUT THIS LABEL MAY CONTAIN PRODUCT WITH TIN-LEAD PLATING.

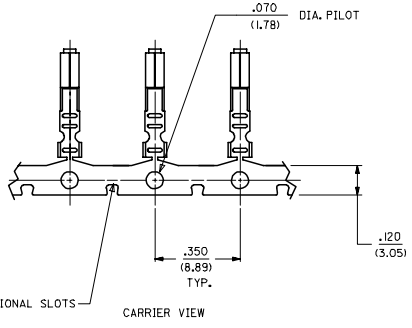
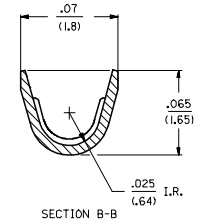
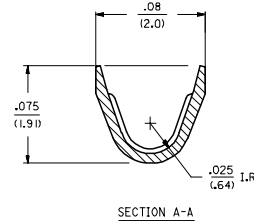
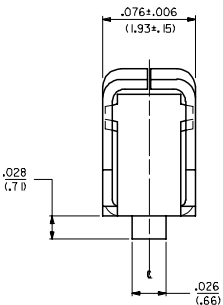
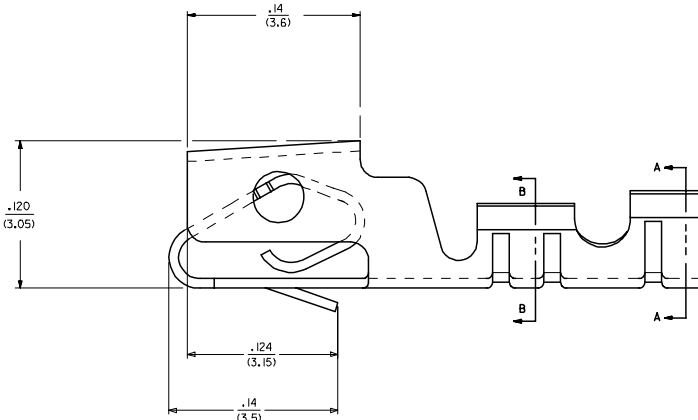
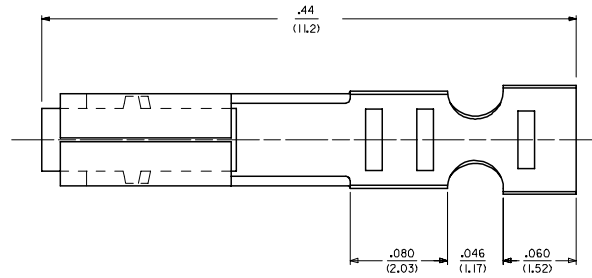

ADD EDP NO'S DEC NO: UCP2006-1006 2006/07/01 DORNWALD/HAG 2006/07/23 CHPKADDER 2006/07/23 APPR:ESMTJH 2006/07/23 ZZ	QUALITY SYMBOLS ▽=0 ▽=0	GENERAL TOLERANCES (UNLESS SPECIFIED)		DIMENSION STYLE IN/MM		SCALE ---	DESIGN UNITS INCH	THIRD ANGLE PROJECTION	
		4 PLACES ± --- ± ---	3 PLACES ± --- ± .010	DRAWN BY GUZIK	DATE 12/22/88	TITLE (2.54)/.100 KK, CRIMP TYPE SHROUDED TERMINAL			
		2 PLACES ± 0.25 ± .014	1 PLACE ± 0.36 ± ---	CHECKED BY PATEL	DATE 12/22/88	APPROVED BY LENZ			
		ANGULAR ±1/2°		MATERIAL NO. SEE CHART		DOCUMENT NO. SD-7879		SHEET NO. 1 OF 2	
DRAFT WHERE APPLICABLE MUST REMAIN WITHIN DIMENSIONS				THIS DRAWING CONTAINS INFORMATION THAT IS PROPRIETARY TO MOLEX INCORPORATED AND SHOULD NOT BE USED WITHOUT WRITTEN PERMISSION					

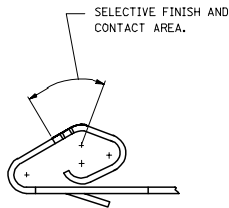

7879-1(***)*			7879-2(***)*		
PART NO.	ENG. NO		PART NO.	ENG. NO	
S 08-55-0128	7879-1P909I	PER ES-7879	50-29-1744	7879-2IP228I	PER ES-7879
S 08-55-0127	7879-1P909L	PER ES-7879	50-29-1745	7879-2IP228L	PER ES-7879
08-55-0124	7879-1P208	PER ES-7879		7879-2IP102I	PER ES-7879
				7879-2IP102L	PER ES-7879
08-55-0129	7879-1P208L	PER ES-7879			
08-50-0004	7879-1P102I	PER ES-7879			
08-50-0005	7879-1P102L	PER ES-7879			
50-29-1900	7879-1P154I	PER ES-7879			

COLUMN NO. 1	CONT. IN COLUMN NO.	SHEET NO.	COLUMN NO. 2	CONT. IN COLUMN NO.	SHEET NO.	COLUMN NO. 3	CONT. IN COLUMN NO.	SHEET NO.
--------------	---------------------	-----------	--------------	---------------------	-----------	--------------	---------------------	-----------

ADD EDP NO'S REC NO: UCP2006-1006 2006/09/01 JORWNAELHAG 2006/09/29 CHKDADER 2006/09/29 APPR:ESH/TH	QUALITY SYMBOLS ▽=0 ▽=0	GENERAL TOLERANCES (UNLESS SPECIFIED) <table border="1"> <tr> <th></th> <th>mm</th> <th>INCH</th> </tr> <tr> <td>4 PLACES</td> <td>± .005</td> <td>± .0005</td> </tr> <tr> <td>3 PLACES</td> <td>± .005</td> <td>± .0005</td> </tr> <tr> <td>2 PLACES</td> <td>± .005</td> <td>± .0005</td> </tr> <tr> <td>1 PLACE</td> <td>± .005</td> <td>± .0005</td> </tr> </table>			mm	INCH	4 PLACES	± .005	± .0005	3 PLACES	± .005	± .0005	2 PLACES	± .005	± .0005	1 PLACE	± .005	± .0005	DIMENSION STYLE IN/MM	SCALE ---	DESIGN UNITS INCH	THIRD ANGLE PROJECTION
			mm	INCH																		
4 PLACES	± .005	± .0005																				
3 PLACES	± .005	± .0005																				
2 PLACES	± .005	± .0005																				
1 PLACE	± .005	± .0005																				
DRAWN BY GUZIK DATE 12/22/88	CHECKED BY PATEL DATE 12/22/88	APPROVED BY LENZ DATE 12/22/88	MATERIAL NO. SEE CHART	DOCUMENT NO. SD-7879	TITLE (2.54)/.100 KK, CRIMP TYPE SHROUDED TERMINAL	SHEET NO. 2																

THIS DRAWING CONTAINS INFORMATION THAT IS PROPRIETARY TO MOLEX INCORPORATED AND SHOULD NOT BE USED WITHOUT WRITTEN PERMISSION