

Design Idea DI-75

LinkSwitch[®] Low Cost 2.5 W Regulated Charger/Adapter



| Application | Device | Power Output | Input Voltage | Output Voltage | Topology |
|-----------------|--------|--------------|---------------|----------------|----------|
| Charger/Adapter | LNK520 | 2.5 W | 85-265 VAC | 5.0 V | Flyback |

Design Highlights

- Replaces a linear transformer based power supply at the same or lower cost, with better output regulation
- No-load input power consumption <300 mW at 230 VAC input: meets worldwide energy efficiency guidelines
- Extremely simple circuit – requires only 26 components!
- Output voltage (CV) tolerance: $\pm 5\%$ at peak power point
- Output current (CC) tolerance: $\pm 25\%$ when $L \leq \pm 10\%$
- Features short-circuit, open loop and thermal protection
- Greater than 70% efficient!
- Meets EN550022 B EMI without a Y-1 Safety capacitor
- Ultra-low leakage current: < 5 μ A at 265 VAC input

Operation

Fusible resistor RF1 gives short-circuit fault protection and limits start-up inrush current. Inductors L1 and L2 and capacitors C1 and C2 form a low-cost pi (π) filter that attenuates conducted EMI. Transformer (T1) winding phasing and D7 orientation let no secondary winding current flow when the U1-MOSFET is ON, so the primary winding current stores its energy in the core of T1. When the U1-MOSFET turns OFF, the energy stored in T1 drives current out of the secondary winding, forward biasing D7, charging C7 and developing/

maintaining the output voltage across C7. The RCD network of C3, D5, R1 and R2 clamps the flyback voltage across the primary winding, as the U1-MOSFET turns OFF.

The bias/feed-back winding provides U1 with CONTROL pin current. In CV mode, that current is controlled by the U2-phototransistor. At start-up and in CC mode, when U2 is OFF, R5 provides the feedback path. Diode D6 is in the return leg of the winding, making it shield the core from the primary winding. The bias winding and the primary-to-secondary shield winding both reduce EMI.

CONTROL pin capacitor C6 stores energy and supplies it to U1 at start-up, determines the “restart attempt rate” in the auto-restart mode, shunts high frequency switching noise around U1 and provides U1 with the instantaneous MOSFET gate-drive current it requires. The combined voltages of VR1, R7 and the U2-LED determine the output voltage. Resistor R8 provides bias current to VR1. The output voltage can be fine-tuned by adjusting the values of R7 and R8.

LinkSwitch solutions must only operate in discontinuous conduction mode. $P_o \approx 0.5 L P f$, where P_o = Output Power, L = transformer primary inductance, I = LinkSwitch peak current, f = Switching frequency. $P f$ is accurately controlled for LinkSwitch; therefore P_o is proportional to L .

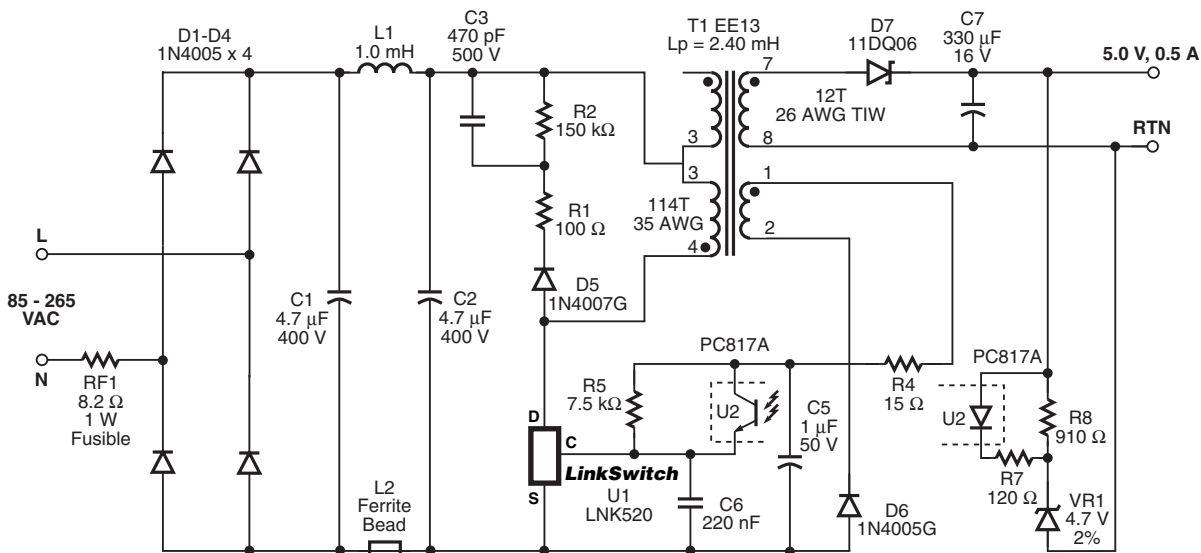

Figure 1. 2.5 W LinkSwitch Based Charger/Adapter.

PI-3869-051204

Typical applications are chargers for cell phones, PDAs, portable audio devices and shavers or power sources embedded within home appliances and consumer electronics, such as TV standby and bias supplies.

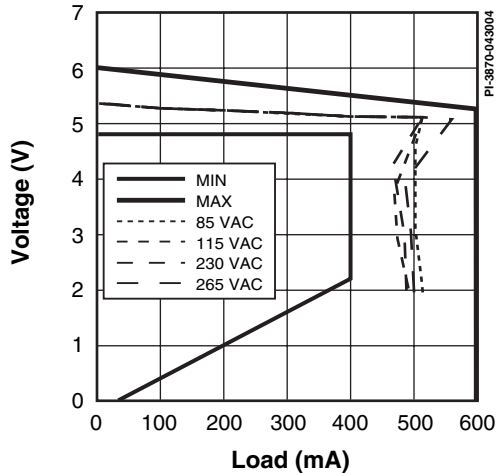

Figure 2. Load Regulation-CV/CC Characteristics.

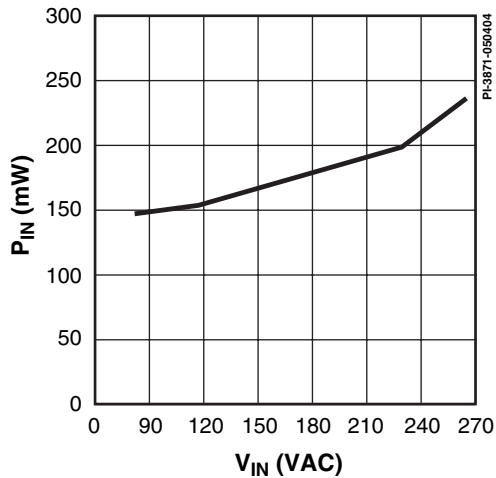

Figure 3. No Load Input Power Consumption.

Key Design Points

- Set V_{OR} within 36 V to 60 V (50 V being optimum)
- Transformer primary inductance tolerance must be $\leq \pm 10\%$, to maintain CC limit tolerances ($\pm 25\%$)
- To allow more time for reaching regulation at startup (or into a fully resistive load), increase C6 to 1 μF
- If battery voltage is less than 2 V, then the *LinkSwitch* will not come out of its auto-restart mode
- To lower the ripple voltage into non-battery loads, an LC filter or LDO must be added onto the output
- Adjust output voltage by changing R8 (and/or VR1) and adjust constant current by changing R5.

| TRANSFORMER PARAMETERS | |
|----------------------------|---|
| Core Material | TDK PC40 EE13, AL = 185 nH/T2 |
| Bobbin | EE13 Horizontal 8 pin |
| Winding Details | Bias: 39T, 34 AWG Primary: 114T, 35 AWG Shield: 13T, 2 x 31 AWG Secondary: 12T, 26 AWG |
| Winding Order (pin number) | Bias: (1-2), tape Primary: (4-3), tape Shield: (3-open), tape Secondary: (7-6), tape |
| Primary Inductance | 2.40 mH |
| Primary Resonant Frequency | 300 kHz (minimum) |

Table 1. Transformer Construction Information.

For the latest updates, visit www.powerint.com

Power Integrations may make changes to its products at any time. Power Integrations has no liability arising from your use of any information, device or circuit described herein nor does it convey any license under its patent rights or the rights of others. POWER INTEGRATIONS MAKES NO WARRANTIES HEREIN AND SPECIFICALLY DISCLAIMS ALL WARRANTIES INCLUDING, WITHOUT LIMITATIONS, THE IMPLIED WARRANTIES OF MERCHANTABILITY, FITNESS FOR A PARTICULAR PURPOSE, AND NON-INFRINGEMENT OF THIRD PARTY RIGHTS. The products and applications illustrated herein (including circuits external to the products and transformer construction) may be covered by one or more U.S. and foreign patents or potentially by pending U.S. and foreign patent applications assigned to Power Integrations. A complete list of Power Integrations' patents may be found at www.powerint.com.

The PI logo, **TOPSwitch**, **TinySwitch**, **LinkSwitch** and **EcoSmart** are registered trademarks of Power Integrations. **PI Expert** and **DPA-Switch** are trademarks of Power Integrations. ©Copyright 2004, Power Integrations

Power Integrations

5245 Hellyer Avenue

San Jose, California 95138

MAIN PHONE NUMBER
+1 408-414-9200

APPLICATIONS HOTLINE
+1 408-414-9660

APPLICATIONS FAX
+1 408-414-9760

For a complete listing of worldwide sales offices, please visit www.powerint.com

