

Temperature Plate Assembly ATTP1A

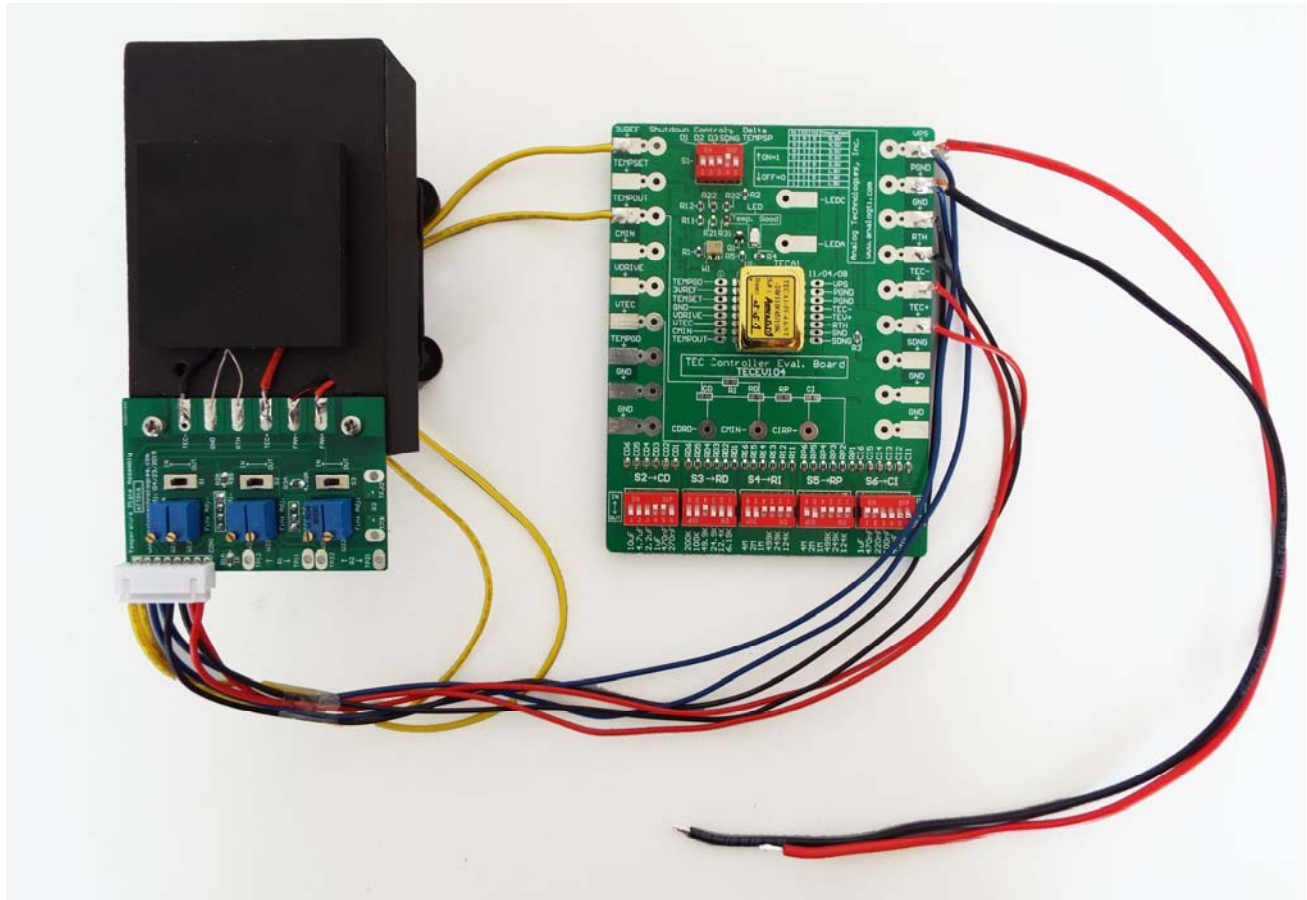

Figure 1. Temperature Plate System

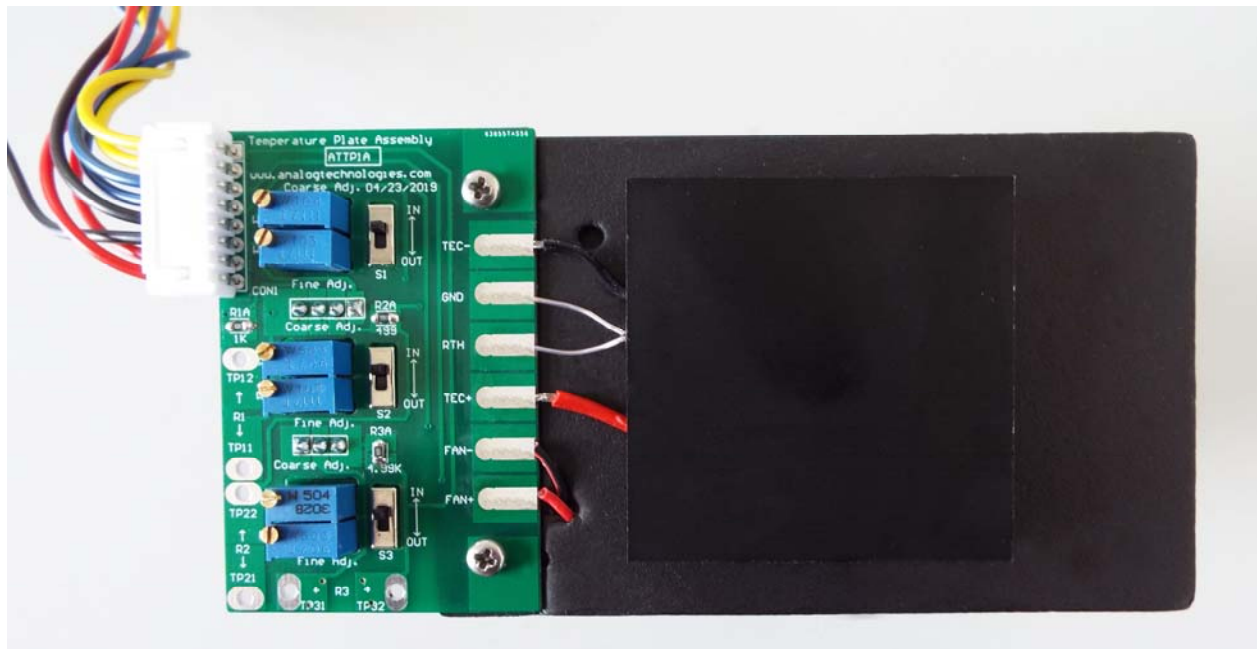

Figure 2. The Physical Photo of ATTP1A

MAIN FEATURES

Large platform for thermal load: 66mm × 44mm

Wide temperature regulation range: -20°C to 110°C

Accurate temperature stability: 1.8mV

Response to large set-point temperature change: 20s from 10 °C to 20°C

Response to small set-point temperature change: 6s from 20°C to 21°C

High thermal load capability: 15.75W

APPLICATIONS

It's widely used for evaluating TEC controllers, TECs and heat sink, etc. Also, it can stabilize an object's temperature for scientific experiments.

DESCRIPTION

ATTP1A is designed for evaluating TEC controllers, which can be easily evaluated by using this temperature plate.

ATTP1A aims to automatically adjust the temperature parameters based on the requested temperature range so that the TEC controller can detect the pre-set temperature range.

Temperature plate ATTP1A works together with TEC controller evaluation board and TEC controller. Figure 2 shows the physical photo of ATTP1A. The TEC evaluation board connects with ATTP1A through CON1. On the right side of ATTP1A, it connects with a TEC module, a thermistor, a fan and a heat sink, see Figure 1. R1 (W11, W12, R1A), R2 (W21, W22, R2A), R3 (W31, W32, R3A) are TEC temperature control parameters, see Figure 2. Required temperature parameters can be achieved through adjusting R1, R2 and R3, thus the TEC controller can detect the temperature range that users require.

In different temperature ranges, R1, R2 and R3 have different corresponding resistances. R1, R2 and R3 can be determined by:

$$R1 = R_{MID} + \frac{R_{MID}(R_{LOW} + R_{HIGH}) - 2 * R_{LOW} * R_{HIGH}}{R_{LOW} + R_{HIGH} - 2 * R_{MID}}$$

$$R2 = R1 - R_{MID}$$

$$R3 = \frac{R1(R1 + R_{LOW} - R_{MID})}{R_{LOW} - R_{MID}}$$

Where R_{HIGH} is the resistance of R_{TH} in the highest temperature of the set temperature range; R_{MID} is the resistance of R_{TH} in the medium temperature of the set temperature range; R_{LOW} is the resistance of R_{TH} in the lowest temperature of the set temperature range. For example, set the highest temperature 35°C and the lowest temperature 15°C, so the medium value is 25°C.

In the R-T table, R_{HIGH} , R_{MID} and R_{LOW} can be achieved, see Table 2.

$$R_{HIGH} = 6.5k; R_{MID} = 10k; R_{LOW} = 15.7k$$

In accordance with the above three formulas, R1, R2 and R3 can be calculated:

$$R1 = 18.14k; R2 = 8.14k; R3 = 75.87k$$

As shown in Figure 4, R1 is equal to the sum of W11 (potentiometer), W12 (potentiometer) and R1A (fixed value resistor), that is, $R1 = W11 + W12 + R1A$. So simply adjust W11 and W12, R1 will be 8.051k. W11 provides coarse adjustment and W12 provides fine adjustment.

The same goes to R2 and R3, that is:

$$R2 = W21 + W22 + R2A$$

$$R3 = W31 + W32 + R3A$$

Where W21 and W31 provide coarse tuning; W22 and W32 provide fine tuning.

At the bottom right side of the plate, there are three switches S1, S2, and S3, which can be used to adjust the temperature parameters. When adjusting R1, R2 and R3, disconnect them with circuit (turn corresponding switch to OUT), thus the measured R1, R2 and R3 are available. When R1, R2 and R3 are all adjusted to the required resistance, turn on all switches (switch to IN).

Solder pad TP11 and TP12 are test points of R1. When the switch is off, use resistance function of the multimeter and connect its two test leads to TP11 and TP12. At this time, adjust W11 and W12, the resistance of R1 can be read in the meter. Users can tune R1 on the basis of calculated temperature parameters and get the required resistance from the multimeter. This method is also applied to R2 and R3. TP21 and TP22 can be used to test R2; TP31 and TP32 can be used to test R3.

There are solder joints on the sides of the board. These solder joints can be used to connect with external devices or components. Test lines of other devices can be placed into the holes of solder pads directly.

Note: It's recommended to set a narrow temperature range, such as 20°C to 30°C; otherwise, the relationship between the TEMP and the actual temperature is not linear.

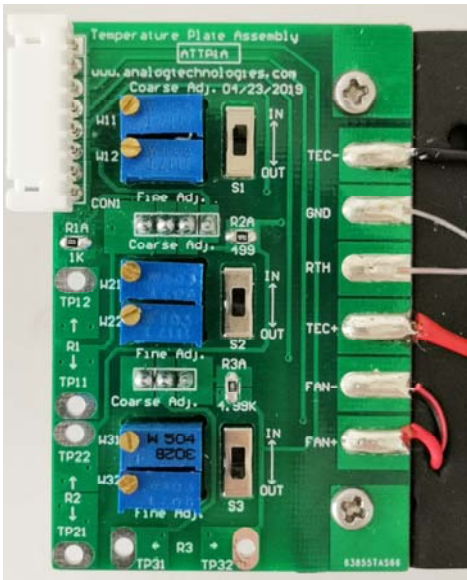





Figure 3. Locations of Potentiometers and Switches

To set the desired temperature range, we can adjust the resistance of R1, R2 and R3. The initial temperature of our controller is $-20^{\circ}\text{C}\sim 110^{\circ}\text{C}$. Based on the above three formulas and Table 2, R1, R2 and R3 can be calculated: $R1=8.05\text{k}$; $R2=3.68\text{k}$; $R3=8.75\text{k}$ (Note: when adjusting the blue potentiometer, turn S1, S2 and S3 to OUT). Before powering on, turn S1, S2 and S3 to IN. The voltage of pin TEMPSET in the evaluation board is $0\text{V}\sim 3\text{V}$, and the corresponding temperature range is $-20^{\circ}\text{C}\sim 110^{\circ}\text{C}$. Change the voltage of TEMPSET by adjusting the white potentiometer. For example, when we adjust the voltage of TEMPSET to 1.5V, then the corresponding temperature is 45°C . Figure 3 shows the locations of the potentiometers and switches.

SPECIFICATIONS

Table 1. Characteristics

Part #	I_{MAX}	V_{MAX}	Q_{MAX}	Size (L×W×H)	Buy Online
TEC Module ATE1-49-4BS	4A	5.6V	14.2W	25mm×25mm×4.5mm	
TEC Controller TEC5V6A-NT	6A	5V	30W	25.6mm×20mm×4.5mm	
	Temperature Range		0°C to 50°C		
	Response Time		<5s		
	High Stability		0.01°C		
Evaluation Board TECEV104	Evaluation board for TEC controller TEC5V6A-NT				

Thermistor ATH10K1R25T70S	Nominal Resistance@ 25°C	Thermistor Diameter	Thermistor Length	Lead Length	Buy Online
	$10\text{k} \pm 1\%$	$1.25 \pm 0.03\text{mm}$	$2.0 \pm 0.5\text{mm}$	$70 \pm 1\text{mm}$	

Heat Sink ATHS-1/2/105/66/30A	Length	Width	Height	Weight	Color	Material	Buy Online
		105mm	66.2mm	30mm	0.245kg/ 0.54lb	Black	Aluminum
Thermal Resistance		2.35°C/W					

Table 2. Resistance vs. Temperature Characteristics for Thermistor ATH10K1R25

Temp. (°C)	Resistance (kΩ)	Temp. (°C)	Resistance (kΩ)	Temp. (°C)	Resistance (kΩ)	Temp. (°C)	Resistance (kΩ)
-40	342.55	6	24.205	52	3.3464	98	0.7262
-39	320.26	7	23.041	53	3.2243	99	0.7051
-38	299.57	8	21.935	54	3.1061	100	0.6825
-37	280.36	9	20.908	55	2.9940	101	0.6639
-36	262.51	10	19.921	56	2.8858	102	0.6463
-35	245.92	11	19.984	57	2.7816	103	0.6280
-34	230.49	12	18.100	58	2.6834	104	0.6102
-33	216.13	13	17.264	59	2.5871	105	0.5932
-32	202.77	14	16.471	60	2.4969	106	0.5766
-31	190.31	15	15.717	61	2.4086	107	0.5605
-30	178.71	16	15.004	62	2.3244	108	0.5449
-29	167.89	17	14.327	63	2.2441	109	0.5229
-28	157.80	18	13.683	64	2.1658	110	0.5153
-27	148.37	19	13.073	65	2.0915	111	0.5013
-26	139.58	20	12.494	66	2.0202	112	0.4877
-25	131.36	21	11.943	67	1.9515	113	0.4745
-24	123.68	22	11.419	68	1.8854	114	0.4617
-23	116.49	23	10.923	69	1.8219	115	0.4493
-22	109.78	24	10.449	70	1.7610	116	0.4371
-21	103.49	25	10.000	71	1.7022	117	0.4256
-20	97.597	26	9.5730	72	1.6457	118	0.4141
-19	92.091	27	9.1658	73	1.5916	119	0.4032
-18	86.912	28	8.7783	74	1.5393	120	0.3927
-17	82.063	29	8.4085	75	1.4891	121	0.3823
-16	77.525	30	8.0586	76	1.4406	122	0.3724
-15	73.259	31	7.7224	77	1.3941	123	0.3628
-14	69.245	32	7.4041	78	1.3494	124	0.3535
-13	65.485	33	7.0995	79	1.3063	125	0.3445
-12	61.958	34	6.8109	80	1.2648	126	0.3356
-11	58.626	35	6.5341	81	1.2246	127	0.3271
-10	55.508	36	6.2711	82	1.1861	128	0.3189
-9	530.5	37	6.0180	83	1.1488	129	0.3109
-8	502.4	38	5.7788	84	1.1131	130	0.3031
-7	476.2	39	5.5496	85	1.0786	131	0.2955
-6	451.3	40	5.3302	86	1.0453	132	0.2882
-5	428.0	41	5.1207	87	1.0132	133	0.2811
-4	405.8	42	4.9211	88	0.9823	134	0.2742
-3	385.1	43	4.7315	89	0.9524	135	0.2675
-2	36.281	44	4.5478	90	0.9236	136	0.2609
-1	34.407	45	4.3740	91	0.8957	137	0.2546
0	32.738	46	4.2082	92	0.8690	138	0.2484
1	31.104	47	4.0484	93	0.8431	139	0.2425
2	29.568	48	3.8944	94	0.8181	140	0.2367
3	28.109	49	3.7485	95	0.7938		
4	26.729	50	3.6085	96	0.7705		
5	25.428	51	3.4764	97	0.7481		

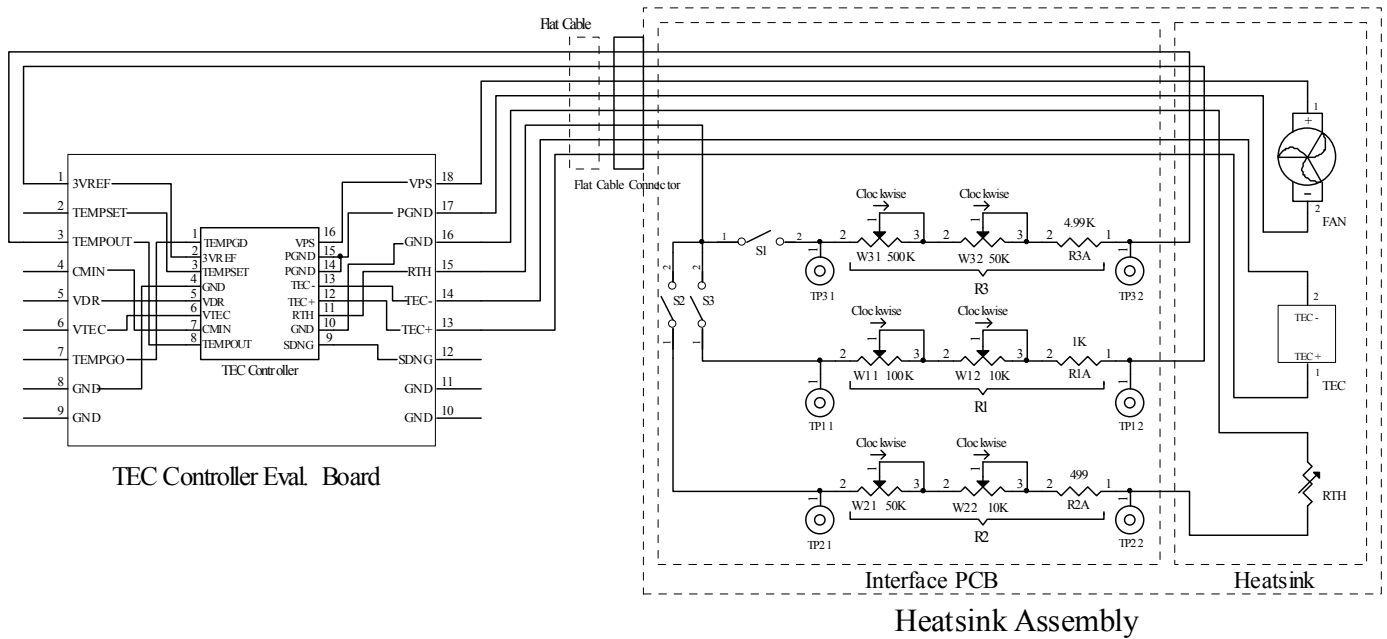

Figure 4. Temperature Plate System Block Diagram

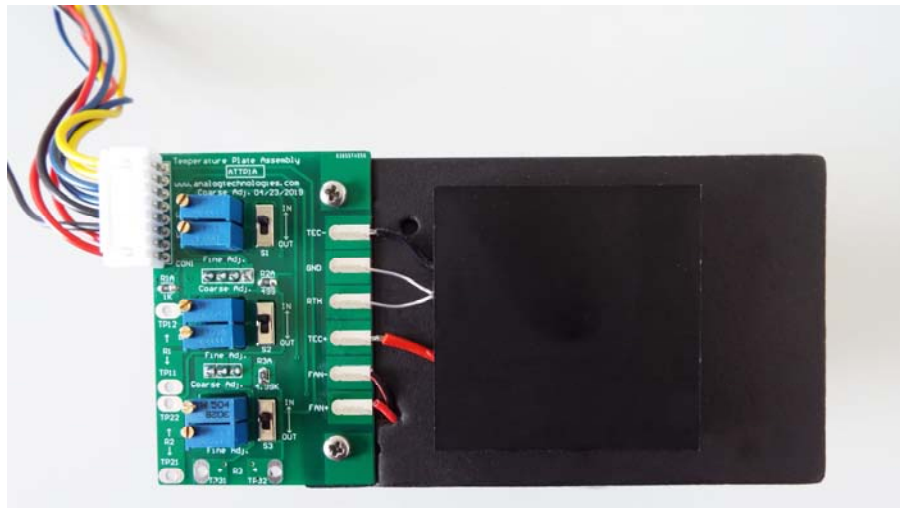

Figure 5. Top View

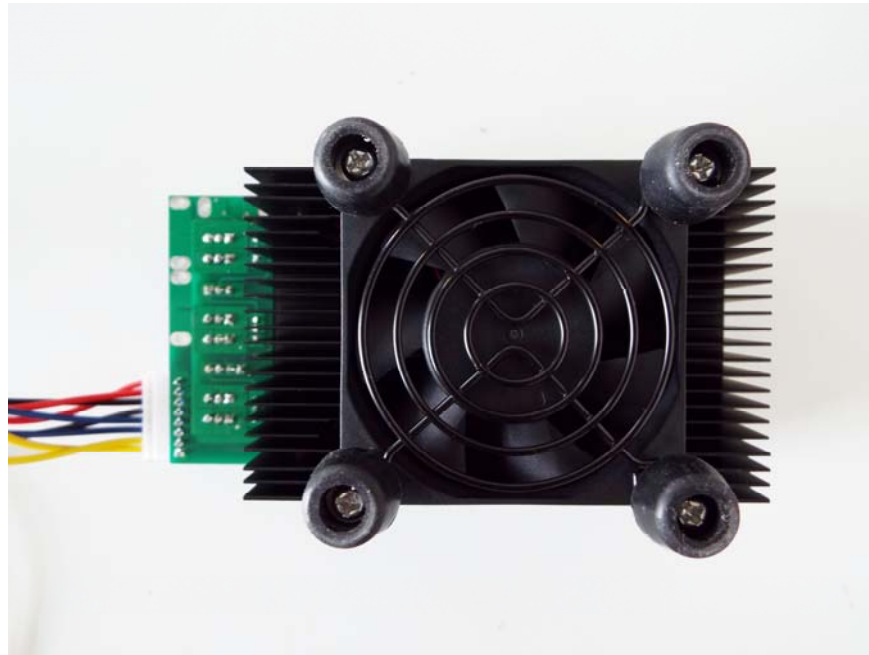

Figure 6. Bottom View

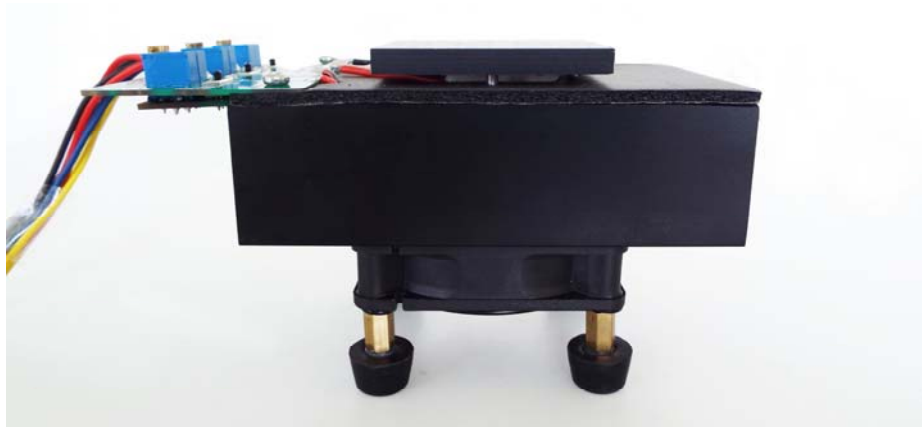

Figure 7. Side View



Figure 8. Side View

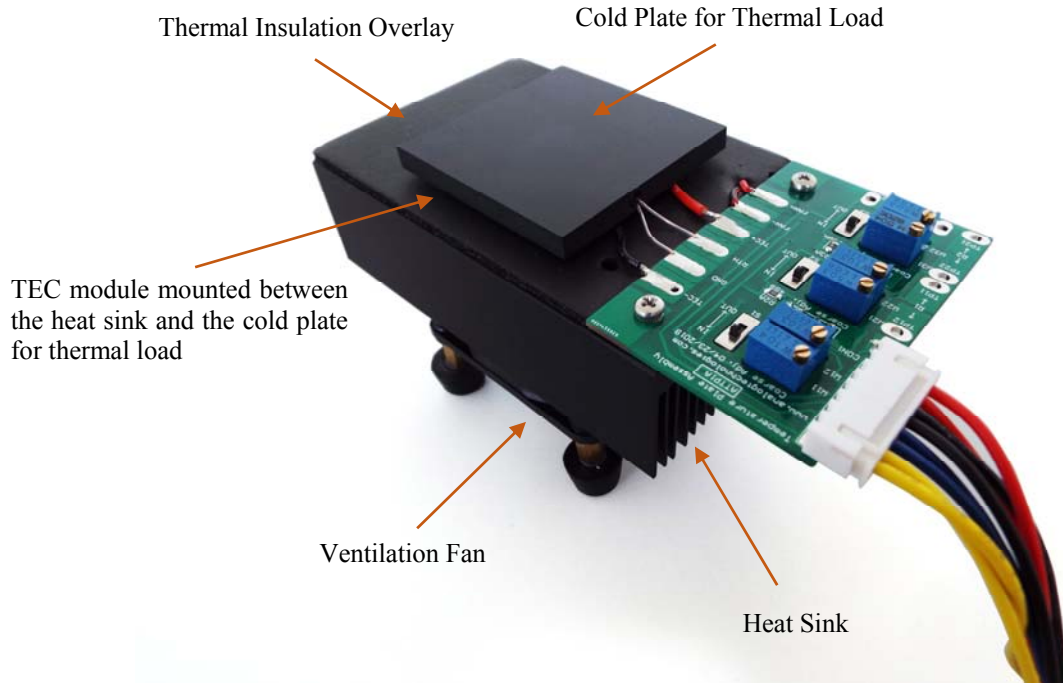

Figure 9. Diagram Illustration

MECHANICAL DIMENSIONS

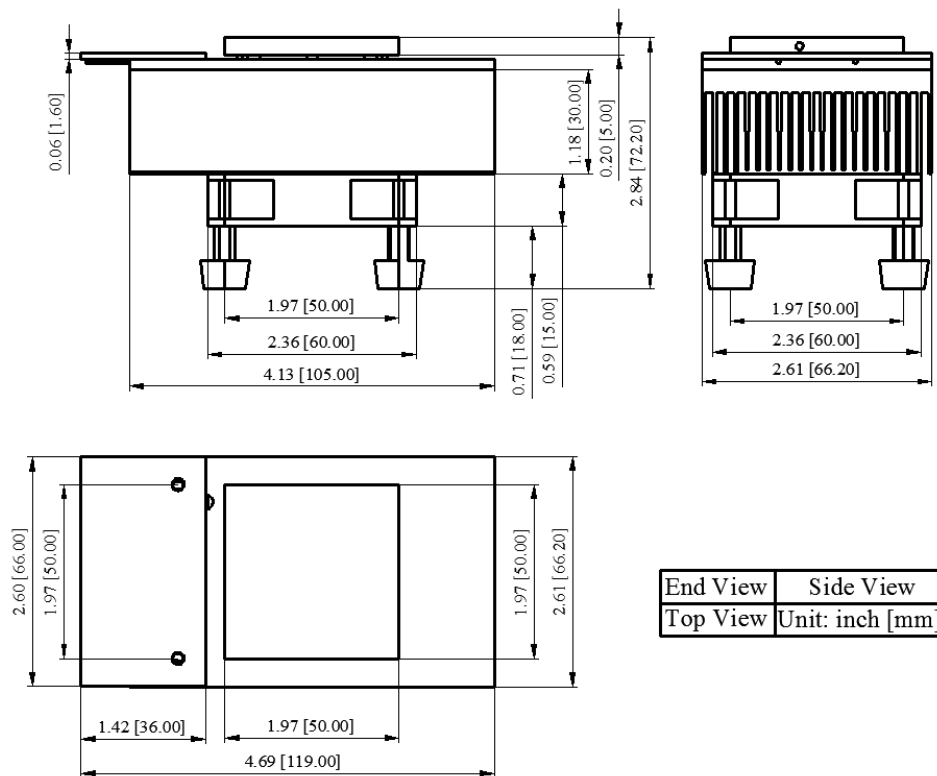

Figure 10. Dimensions of ATTP1A



NOTICE

1. ATI reserves the right to make changes to its products or to discontinue any product or service without notice and advise customers to obtain the latest version of relevant information to verify, before placing orders, that information being relied on is current and complete.
2. ATI reserves the right to make changes to its products or to discontinue any product or service without notice, and advise customers to obtain the latest version of relevant information to verify, before placing orders, that information being relied on is current and complete.
3. All products are sold subject to the terms and conditions of sale supplied at the time of order acknowledgment, including those pertaining to warranty, patent infringement, and limitation of liability. Testing and other quality control techniques are utilized to the extent ATI deems necessary to support this warranty. Specific testing of all parameters of each device is not necessarily performed, except those mandated by government requirements.
4. Customers are responsible for their applications using ATI components. In order to minimize risks associated with the customers' applications, adequate design and operating safeguards must be provided by the customers to minimize inherent or procedural hazards. ATI assumes no liability for applications assistance or customer product design.
5. ATI does not warrant or represent that any license, either expressed or implied, is granted under any patent right, copyright, mask work right, or other intellectual property right of ATI covering or relating to any combination, machine, or process in which such products or services might be or are used. ATI's publication of information regarding any third party's products or services does not constitute ATI's approval, warranty or endorsement thereof.
6. IP (Intellectual Property) Ownership: ATI retains the ownership of full rights for special technologies and/or techniques embedded in its products, the designs for mechanics, optics, plus all modifications, improvements, and inventions made by ATI for its products and/or projects.